



## City Research Online

### City, University of London Institutional Repository

---

**Citation:** Dhand, A. & Pullen, K. R. (2016). Analysis of Dual Mode Continuously Variable Transmission for Flywheel Energy Storage Systems. SAE Technical Papers, . 2016\_01\_1177. doi: 10.4271/2016-01-1177

This is the accepted version of the paper.

This version of the publication may differ from the final published version.

---

**Permanent repository link:** <http://openaccess.city.ac.uk/15189/>

**Link to published version:** <http://dx.doi.org/10.4271/2016-01-1177>

**Copyright and reuse:** City Research Online aims to make research outputs of City, University of London available to a wider audience. Copyright and Moral Rights remain with the author(s) and/or copyright holders. URLs from City Research Online may be freely distributed and linked to.

---

City Research Online:

<http://openaccess.city.ac.uk/>

[publications@city.ac.uk](mailto:publications@city.ac.uk)

---

# Analysis of dual mode continuously variable transmission for flywheel energy storage systems

Aditya Dhand and Keith Pullen  
City University London

## Abstract

There are different types of energy storage devices which are used in today's hybrid and electric vehicles. Batteries, ultra capacitors and high speed flywheels are the most commonly used ones. While batteries and supercapacitors store energy in the form of electric energy, the flywheel (FW) is the only device that keeps the energy stored in the original form of mechanical energy the same as the moving vehicle. The flywheel needs to be coupled to the driveshaft of the vehicle in a manner which allows it to vary its speed independently of the moving vehicle in order to vary its energy content. In other words a continuously variable transmission (CVT) is needed. The common mechanical variators used in automotive applications, namely the rolling traction drives and the belt drives, have the disadvantage that their speed ratio range defined as the maximum to minimum speed ratio is generally not sufficient for flywheel energy storage system (FESS). One of the ways to improve the ratio range is by using a dual mode transmission, where the ratio coverage of the variator is exploited twice. This paper presents the fundamental kinematics of such a transmission including its variants. The equations of speed ratio, power flow and efficiency are derived for a variator only transmission and a power split CVT (PSCVT) used in dual mode and the results compared.

## Introduction

Flywheels are excellent energy storage devices and several applications in road vehicles are under development [1]. They can be used as energy storage devices for hybridization with internal combustion engine (ICE) as prime mover [2] or they can be used along side a battery in hybrid energy storage to load level the battery [3]. Flywheels have the characteristics of high specific power, adequate specific energy, long cycle life, high energy efficiency, quick recharge, low cost and environmental friendliness. Unlike battery they store energy in mechanical form thus avoiding conversion while exchanging energy with the vehicle. Also unlike battery they do not suffer from temperature dependence and their state of energy is most easily determined. Since a battery can either have high specific power or high specific energy but not both, flywheels can improve the energy efficiency of the battery by taking care of the peak loads in hybrid energy storage [4]. These characteristics make them very attractive as secondary storage device to be used in hybrid vehicles (HV) as well as electric vehicles (EV). The flywheel needs to be able to change its speed to exchange energy with the vehicle and this is to be allowed independently of the velocity of the vehicle. Thus, the transmission has to be continuously variable in nature. The CVT can be of various types such as electrical

or mechanical, though usually the mechanical one is the most attractive option as using the electrical transmission can detract from the benefits of having the FW, except in a few particular circumstances. The main differences between the mechanical CVT used in conventional vehicle as compared to the ones required for FESS is that they have to be bi-directional, highly efficient in both directions and have sufficiently high speed ratio range, which is defined as the maximum to minimum speed ratio.

Different types of variators have existed and currently traction drives are the most common in automotive application, and are deemed a mature, low-cost and fuel-efficient technology [5]. In the traction drive, power is transmitted between two loaded objects through adhesive friction and the two types commonly used are the belt drives and the rolling traction drives. Fuchs et al. [6] and Srivastava and Haque [7] have given a detailed review of the toroidal variator and the belt type respectively. However as stated before the drawback for these variators is that their speed ratio range is very limited and most designs available today have a ratio span from around 0.4 to 2.4 giving a ratio range of 6, which generally is not sufficient for FESS. The speed ratio range strongly affects the performance of the flywheel hybrid vehicle [8]. In case the flywheel capacity is to be increased for downsizing the main prime mover or the entire vehicle speed range is to be covered, a higher speed ratio range would be needed. As compared to fixed ratio gearing, the efficiencies of variators are usually lower. Kluger and Long [9] suggested that the highest achievable overall efficiencies for the belt type and toroidal type CVT are expected to be 88.4% and 91% respectively.

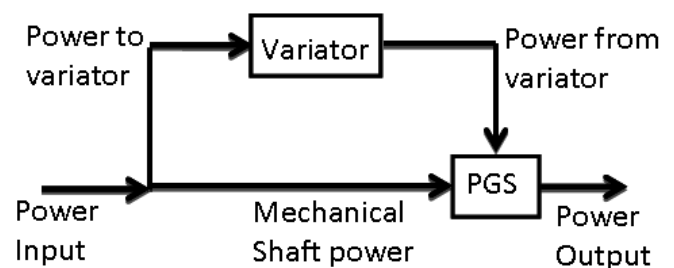

Figure 1 PSCVT

The PSCVT, a combination of variator and planetary gear set (PGS) (shown in fig.1), is usually used to improve the efficiency of the transmission by allowing part of the power to be transmitted via the highly efficient direct mechanical linkage while the rest of the power is transmitted through the variator. The PSCVT can be designed to achieve the desired speed ratio range and high efficiency by

increasing its complexity. Dhand and Pullen [10] have explored in detail the concept of PSCVT for FESS and the various modes of operation possible including power recirculation and multi-regime mode. The authors have presented a methodology which can be applied to design single and multi-regime PSCVT for FESS to provide any required speed ratio coverage and predict its efficiency in both directions of power flow. Another way of achieving the required high ratio range is the so called dual mode CVT or “i2” CVT control [11] where the variator ratio coverage is exploited twice. When the CVT reaches its maximum speed ratio, the input and output shafts are interchanged using clutches and the ratio coverage can be used again. In another variant of this kind of arrangement, instead of the variator, a PSCVT arrangement is utilized and its ratio coverage exploited twice in a similar manner. There are only few examples in literature of this kind of transmission being utilized in a flywheel hybrid vehicle (Kok [11], Dietrich et al. [12] and Locker and Miller [13]); however the fundamental kinematics of such a transmission have not been presented. The current paper discusses the concept of dual mode CVT. The authors follow a similar methodology, as shown in [10] of deriving equations of speed ratio, ratio of variator power to input power and efficiency for the transmission. Two variants namely the variator only system and the PSCVT system without power recirculation in dual mode are described and compared.

### Kinematics of variator only dual mode CVT

This section deals with the basic variator only dual mode design. This design has increased complexity since the ratio of the CVT is traversed twice. Fig 2 shows the design which is a variator only design and involves 4 clutches. The power flows through the variator twice to cover the ratio range. In the fig. 2 V is the speed ratio of the variator.  $G_1$ ,  $G_2$  and  $G_3$  are fixed gear ratios, which are needed to attain speed synchronization for the mode change as well choose a desired starting minimum speed ratio (This is required to compare results of the two systems discussed in the paper). A, B C and D are the four clutches to achieve the dual mode.  $r$  is the speed ratio of the system. In the equations throughout the paper  $n$  signifies speed. In fig. 2 and all the figures describing the CVT which follow in the paper, the arrows signify power. Power is input via branch 1 and is output via branch 9.

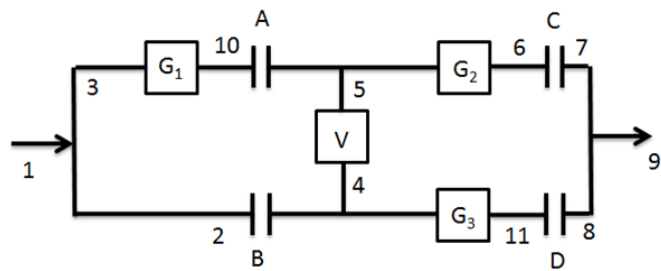

Figure 2 Dual mode variator only transmission

For the above design, the following equations (1-5) define the various speed ratios.

$$r = \frac{n_9}{n_1} \quad (1)$$

$$V = \frac{n_5}{n_4} \quad (2)$$

$$G_1 = \frac{n_{10}}{n_3} \quad (3)$$

$$G_2 = \frac{n_6}{n_5} \quad (4)$$

$$G_3 = \frac{n_{11}}{n_4} \quad (5)$$

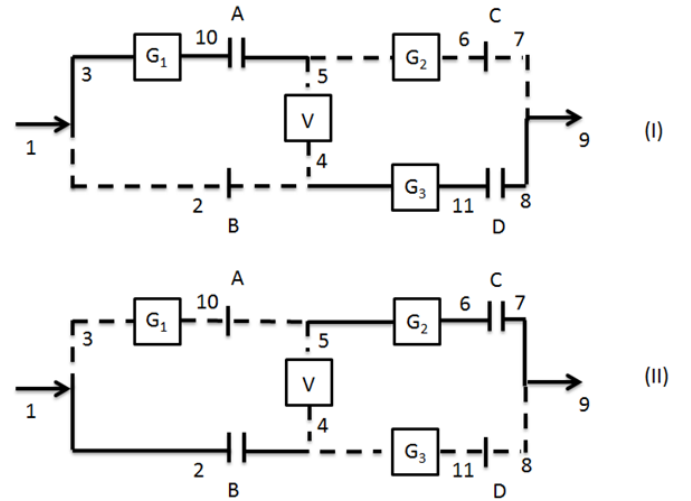

Figure 3 Power flow during the two stages of the variator only dual mode transmission (dashed lines show the current power flow)

During stage 1, clutches B and C are closed and A and D are open. Fig. 3 (I) shows the power flow during stage 1 marked by dashed lines. Equation (6) gives the speed ratio of the stage 1.

$$r = VG_2 \quad (6)$$

To fix a desired start speed ratio of the system ( $r_{\min}$ ), the equation (7) should be true.

$$G_2 = \frac{r_{\min}}{V_{\min}} \quad (7)$$

For stage 2, clutches A and D are closed and B and C are open. Fig. 3 (II) shows the power flow during stage 2 marked by dashed lines. Equation 8 gives the speed ratio of the stage 2.

$$r = \frac{G_1 G_3}{V} \quad (8)$$

For synchronization, the speed of the shaft 10 ( $n_1 \times G_1$ ) should be equal to the shaft 5 ( $n_1 \times V_{\max}$ ) and the speed of shaft 11 ( $n_1 \times G_3$ ) and 8 ( $n_8$ ) should be equal at the end of stage 1. To achieve these conditions the following equations (9-10) should be true.

$$G_1 = V_{\max} \quad (9)$$

$$G_3 = V_{\max} \times G_2 = V_{\max} \times \frac{r_{\min}}{V_{\min}} \quad (10)$$

The ratio range would be equal to square of the variator ratio range since it is being traversed twice. In the equation (11-13)  $V_t$  is the ratio range of variator and  $r_t$  is the ratio range of transmission.

$$r_t = \frac{r_{\max}}{r_{\min}} \quad (11)$$

$$V_t = \frac{V_{\max}}{V_{\min}} \quad (12)$$

$$r_t = V_t^2 \quad (13)$$

As mentioned before,  $V_t$  of currently available variators is about 6, which would make  $r_t$  of this type of transmission 36. This is more than adequate for an FESS application and in fact might be well on the higher side. This high ratio coverage could be utilized in two ways. Either a smaller ratio range variator could be used which would be lower in cost or the operation of the FESS could be narrowed to high efficiency regions of the variator ratio. Though another important consideration is that the complete power flows through the variator at all times, which would cause a drop of efficiency, since it is the least efficient of all the elements and the variator would have to be sized larger to carry the entire power. A variation of this design is the dual mode PSCVT system where both the stages are PSCVT without power recirculation. One of the stage would be Output coupled (OC) and the other Input coupled (IC). This type of design would avoid passing the entire power through variator at all times, leading to a higher efficiency across the speed range. The next section explores this option. Losses are only considered in the gears which are in the path of the power flow from input to output.

## Kinematics of dual mode PSCVT

For the dual mode PSCVT, firstly the kinematics of the PGS are given explained very briefly. The basic ratio R for a PGS can be defined as the ratio of speeds of any two shafts when the third one is held stationary. Six ratios can be defined by taking different members as input, output and the stationary element, though they can be easily derived from one another. For more detail about the kinematics of the planetary gear set (PGS) refer to White [14]. The advantage of White's [14] analysis is that it does not assign specific branches of the PGS to its general kinematic equation thereby leading to a set of

equations that can be applied to any PGS configuration within the PSCVT. In this analysis, like that of White's [14] the PGS members will not be specifically defined and generalized equations will be derived. The fig 4 shows the general PGS with three branches labeled as 1, 2 and 3. Equations (14-15) define the basic ratio.

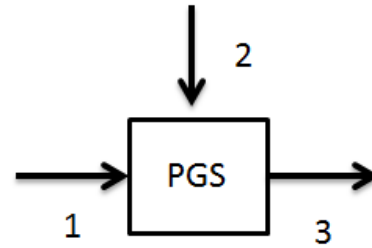

Figure 4 Schematic of PGS (Arrows signify power. Power into the system is taken positive and out of the system as negative)

$$R = \left( \frac{n_3}{n_1} \right)_{n_2=0} \quad (14)$$

$$R = \frac{(n_3 - n_2)}{(n_1 - n_2)} \quad (15)$$

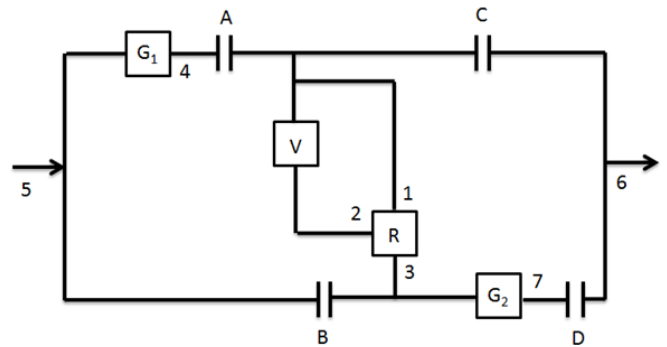

Figure 5 Dual-mode PSCVT

The figure 5 shows this type of design. It involves 4 clutches to achieve the dual mode operation as in the previous case. Further it includes a PGS to constitute the PSCVT. For the above design, the following equations (16-19) define the various speed ratios.

$$r = \frac{n_6}{n_5} \quad (16)$$

$$V = \frac{n_1}{n_2} \quad (17)$$

$$G_1 = \frac{n_4}{n_5} \quad (18)$$

$$G_2 = \frac{n_7}{n_3} \quad (19)$$

For stage 1, the system is taken as OC PSCVT, though it can easily be the other way around i.e. IC PSCVT by controlling the clutches differently. The clutches B and C are closed, and A and D are open. Equation (20) gives the relation between  $r$ ,  $V$  and  $R$ . Fig. 6 (I) shows the power flow during stage 1 marked by dashed lines.

$$r = \frac{V}{VR - R + 1} \quad (20)$$

For stage 2, the system will behave as IC PSCVT. The clutches A and D are closed and B and C are open. Equation (21) gives the relation between  $r$ ,  $V$  and  $R$ . Fig. 6 (II) shows the power flow during stage 2 marked by dashed lines.

$$r = G_1 \times G_2 \times \left( R + \frac{(1-R)}{V} \right) \quad (21)$$

Again as in the previous case for synchronization, the speeds of shafts 6 ( $n_6$ ) and 4 ( $n_5 \times G_1$ ) should be equal at the end of stage 1. Similarly those of shafts 7 ( $n_5 \times G_2$ ) and 6 ( $n_6$ ) should be equal at the end of stage 1. For this purpose the following equation (22) should be true.

$$G_1 = G_2 = \left( \frac{V_{\max}}{V_{\max} R - R + 1} \right) \quad (22)$$

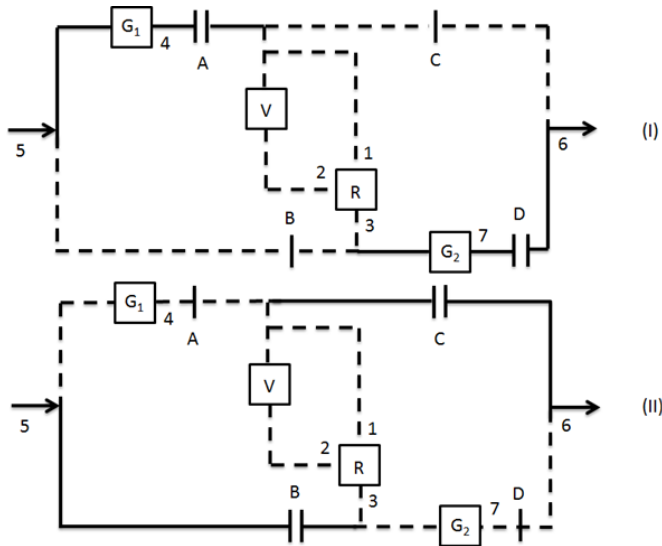

Figure 6 Power flow during the two stages of the PSCVT dual mode transmission (dashed lines show the current power flow)

The advantage of this system over the previous one is that the efficiency will be higher due to the power split and the variator can be sized smaller, however the ratio range will be reduced.

## Efficiency and power flow

In the previous sections, the speed ratio was calculated for both the systems. In this section the ratio of variator to input power and efficiency for the transmission will be shown separately for the individual stages described previously. For this purpose, firstly the efficiencies of the individual components will be defined. The symbols  $\eta_G$  and  $\eta_v$  denote the efficiency of the fixed gears and variator respectively. It is assumed that these efficiencies are the same in both directions of power flow, though the efficiency especially that of the variator would be different in practice in both directions and can be easily incorporated in the equations. The efficiency of the individual path in the PGS is defined as  $\eta_{m(n-p)}$  where m denotes the fixed link and the power is flowing from n to p [15]. Further losses are only considered in the gears which are in the path of the power flow from input to output during the individual stages. Again applying the methodology described in [10], the following table 1 shows the ratio of variator to input power and efficiency of the transmission.

Figure 7 Equations for power flow and efficiency for the two systems

		Variator only	PSCVT
$\frac{P_v}{P_i}$	Stage 1	1	$(1-R)\eta_{1(3-2)} \frac{r}{V}$
	Stage 2	$\eta_{G1}$	$\eta_{G1} \left( \frac{\frac{1}{\eta_v V}}{\frac{1}{\eta_v V} + \frac{R\eta_{1(2-3)}}{(1-R)\eta_{2(1-3)}}} \right)$
$\eta$	Stage 1	$\eta_{G2}\eta_v$	$rR\eta_{2(3-1)} + \frac{r\eta_v(1-R)\eta_{1(3-2)}}{V}$
	Stage 2	$\eta_{G1}\eta_v\eta_{G3}$	$\frac{r}{\frac{G_1 G_2}{\eta_{G1}\eta_{G2}} \left( \frac{R}{\eta_{2(1-3)}} + \frac{(1-R)}{V\eta_v\eta_{1(2-3)}} \right)}$

## Results and Comparison

To compare the systems numerically, following values need to be defined as shown in (23-28). The equation (24) defines the ratio of ring gear diameter ( $D_r$ ) to sun gear diameter ( $D_s$ ) for the PGS and the equation (25) defines the numerical value of R.

$$r_{\min} := 0.47 \quad (23)$$

$$V_{\min} := 0.4 \quad (24)$$

$$V_{\max} := 2.4 \quad (25)$$

$$V_t := 6 \quad (26)$$

$$\frac{D_r}{D_s} := 3 \quad (27)$$

$$R = \frac{D_s}{D_s + D_r} := 0.25 \quad (28)$$

Using the above values and previously derived equations, the speed ratio for the two systems is computed. The following fig. 7 shows a comparison of the two systems using a standard variator with  $V_t$  of 6. The dual stage can easily be seen for both the configurations. For the variator only design the speed ratio varies from 0.47 ( $r_{\min}$ ) to 16.94 ( $r_{\max}$ ) and for the PSCVT from 0.47 ( $r_{\min}$ ) to 6.71 ( $r_{\max}$ ). The speed ratio range for each stage of the variator only design is 6 and for the PSCVT is 3.78. Consequently  $r_t$  for the variator only transmission is 36 and for the PSCVT is 14.27. The suitability of the design will of course depend on the nature of the application and its requirements. For example in cases where the flywheel needs to cover only limited vehicle speed range, the ratio range requirements will be lower and dual mode PSCVT will be more suitable.

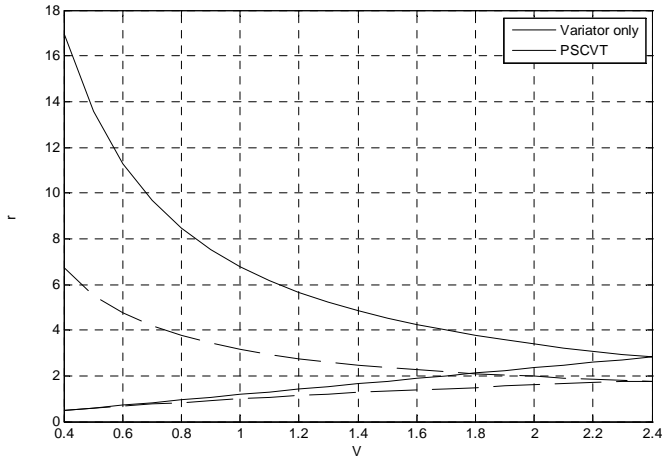

Figure 8 Speed ratio of transmission vs. speed ratio of variator for the two discussed systems

Further efficiency of individual elements needs to be assumed to calculate power flow and overall efficiency of the transmission. For the sake of simplicity, the efficiencies of the variator and the fixed gears are assumed to be constant and the efficiency of the PGS is taken to be same in all directions, though it can also be derived depending on the direction of power flow [15-16]. The following equations (29-31) define the values.

$$\eta_G := 0.99 \quad (29)$$

$$\eta_{m(n-p)} := 0.98 \quad (30)$$

$$\eta_v := 0.85 \quad (31)$$

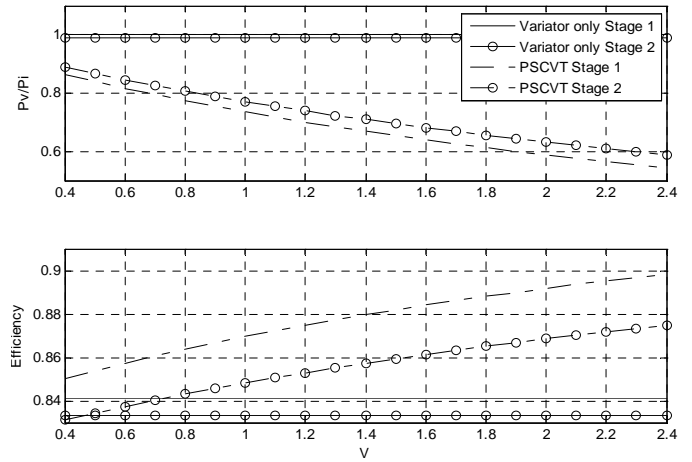

Figure 9 Ratio of variator to input power and efficiency vs. variator ratio for the two systems

Fig. 8 shows a comparison of the ratio of variator to input power and efficiency for the two systems. It can be clearly seen that in the graph that the ratio of power going through the variator is relatively smaller in the PSCVT system and goes as low as 54% towards the higher variator ratio. The effect of this is seen in the lower graph of efficiencies where the PSCVT system exhibits a higher efficiency than the variator only system for most part of the two stages with the efficiencies getting close towards the end of stage 2. The difference in the efficiency between stage 1 and stage 2 of the PSCVT system is due to the PSCVT system behaving as output coupled in stage 1 and input coupled in stage 2.

## Conclusions

The flywheel is an important energy storage device for application in hybrid and electric vehicles. The flywheel needs a CVT mechanism to connect it to the vehicle driveline. The requirements for the CVT for a FESS are quite different from the ones used in conventional vehicles. The speed ratio range required for a FESS is much higher than that for a conventional system. The PSCVT is traditionally used to improve the efficiency and ratio range of the conventional variators. Another more uncommon method is to use a dual mode CVT, which has been used for few flywheel hybrid vehicle applications in literature, though the fundamental analysis of such a system has not been presented. This paper presented the fundamental kinematics of the dual mode CVT for FESS. Two variants namely the variator only system and the PSCVT system without power recirculation are described and their speed ratio, power flow and efficiency compared. The variator only system provides a higher speed ratio range as the full range of the variator is utilized twice, though it has a lower efficiency and has to be sized bigger. The PSCVT dual mode system provides a smaller range, though efficiency of the system is higher. Overall the systems add to the complexity while achieving a higher speed ratio range.

## References

1. Dhand, A. and Pullen, K., "Review of Flywheel based Internal Combustion Engine Hybrid Vehicles", *International Journal of Automotive Technology*, 14(5): 797-804, 2013

2. Diego-Ayala, U., Martinez-Gonzalez, P., McGlashan, N. and Pullen, K., "The mechanical hybrid vehicle: an investigation of a flywheel-based vehicular regenerative energy capture system", *Proceedings of the Institution of Mechanical Engineers, Part D: Journal of Automobile Engineering*, 222(11): 2087–2101, 2008
3. Dhand, A. and Pullen, K., "Review of Battery Electric Vehicle Propulsion Systems incorporating Flywheel Energy Storage", *International Journal of Automotive Technology*, 16(3): 487-500, 2015
4. Dhand, A. and Pullen, K., "Characterization of Flywheel Energy Storage System for Hybrid Vehicles", SAE Technical Paper 2014-01-1796, 2014
5. Maeder, K., "Continuously variable transmission: Benchmark, status and potentials", 4<sup>th</sup> International CTI Symposium, Berlin, Germany, 2005
6. Fuchs, R., Tamura, T., McCullough, N. and Matsumoto, K., "The Making of the Full Toroidal Variator", *JTEKT Engineering Journal English edition*, 1006E, 2009
7. Srivastava, N. and Haque., I., "A review on belt and chain continuously variable transmissions (CVT): Dynamics and control", *Mechanism and Machine Theory*, 44(1): 19-41, 2009
8. Murphy, I., "Key factors in optimizing the performance of flywheel hybrid systems", Low Carbon Vehicles Conference, London, United Kingdom, 2009
9. Kluger, M. and Long, D., "An Overview of Current Automatic, Manual and Continuously Variable Transmission Efficiencies and Their Projected Future Improvements", SAE Technical Paper 1999-01-1259, 1999
10. Dhand, A. and Pullen, K., "Analysis of continuously variable transmission for flywheel energy storage systems in vehicular application", *Proceedings of the Institution of Mechanical Engineers, Part C: Journal of Mechanical Engineering Science*, 229(2): 273-290, 2015
11. Kok, D., "Design optimisation of a flywheel hybrid vehicle", PhD thesis, Technical University Eindhoven, 1999
12. Dietrich, P., Eberle, M. and Hörler, H., "Results of the ETH – Hybrid III – Vehicle Project and Outlook", SAE Technical Paper 1999-01-0920, 1999
13. Locker, D. and Miller, M., "Flywheel-electric hybrid vehicle", 4<sup>th</sup> International Electric Vehicle Symposium, 1976
14. White, G., "Properties of Differential Transmissions", *The Engineer*, 224: 105–11, 1967
15. Pennestri E., and Freudenstein, F., "The mechanical efficiency of epicyclic gear trains", *Journal of Mechanical Design*, 115: 645-651, 1993
16. Macmillan, R., "Power flow and loss in differential mechanisms", *Journal of Mechanical Engineering Science*, 3(1): 37-41, 1961

<b>FW</b>	Flywheel
<b>HV</b>	Hybrid vehicle
<b>IC</b>	Input coupled
<b>ICE</b>	Internal combustion engine
<b>OC</b>	Output coupled
<b>PGS</b>	Planetary gear set
<b>PSCVT</b>	Power split continuously variable transmission

## Contact Information

Aditya Dhand, adityadhand@gmail.com

## Definitions/Abbreviations

<b>CVT</b>	Continuously variable transmission
<b>EV</b>	Electric vehicle
<b>FESS</b>	Flywheel energy storage system