



City Research Online

City St George's, University of London

Citation: Kovacevic, A., Stosic, N., Mujic, E. & Smith, I. K. (2007). CFD Integrated Design of Screw Compressors. *Engineering Applications of Computational Fluid Mechanics*, 1(2), pp. 96-108. doi: 10.1080/19942060.2007.11015185

This is the accepted version of the paper.

This version of the publication may differ from the final published version. To cite this item please consult the publisher's version.

Permanent repository link: <https://openaccess.city.ac.uk/id/eprint/20586/>

Link to published version: <https://doi.org/10.1080/19942060.2007.11015185>

Copyright and Reuse: Copyright and Moral Rights remain with the author(s) and/or copyright holders. Copies of full items can be used for personal research or study, educational, or not-for-profit purposes without prior permission or charge, unless otherwise indicated, provided that the authors, title and full bibliographic details are credited, a hyperlink and/or URL is given for the original metadata page and the content is not changed in any way. For full details of reuse please refer to [City Research Online policy](#).

CFD INTEGRATED DESIGN OF SCREW COMPRESSORS

Ahmed Kovacevic, Nikola Stosic, Elvedin Mujic, Ian K. Smith
Centre for Positive Displacement Compressor Technology. City University London
United Kingdom

Corresponding author:

Dr Ahmed Kovacevic, City University, SEMS, Northampton Square, EC1V 0HB, London, UK
tel: +44 220 7040 8780; fax: +44 20 7040 8566, e-mail: a.kovacevic@city.ac.uk

ABSTRACT

Positive displacement screw machines are used in variety of applications such as compressors, expanders, blowers, vacuum pumps, liquid and multiphase pumps. To improve their appearance, efficiency and robustness they are designed with the aid of analytical tools, based often on one-dimensional flow models solved by numerical methods that are confirmed by experiment. Continuing demand for further improvements has led to the need for improved assessment of fluid flow losses in the inlet and outlet openings and how these are affected by the shape of the ports, the deformation of machine components due to the effects of pressure and temperature gradients and their effect on performance, the behaviour of multiphase flows and many other effects. These require more advanced analytical procedures, based on three dimensional numerical flow analysis and fluid-structure interaction.

The way to estimate these phenomena is to use CFD analysis and to integrate the results with three dimensional CAD systems. As computers become cheaper and faster and advances are made in numerical methods, such techniques are becoming available for everyday use by design engineers.

This paper describes how CFD is merged with other design software by means of an integral management system to obtain interactive control of the entire design process of screw compressors. The methods described are of considerable scope and can be applied, not only to screw compressors but also to any other type of twin rotor rotary machines with parallel axes, such as gear pumps, multiphase pumps, vacuum pumps and roots blowers.

KEYWORDS

Screw Compressor, CFD, Computational Continuum Mechanics, CAD, Design Integration

1. INTRODUCTION

Twin screw machines of the rotary positive displacement type are capable of efficient operation with variety of fluids over a wide range of operating pressures and flow rates. Compared to other types of positive displacement machine, their design is simple, with the two rotors comprising the only moving parts. Thus, they can rotate at relatively high speeds and are therefore both reliable and compact. Consequently, a large percentage of all positive displacement compressors now manufactured and in use are of this type.

Screw machines can be used both as compressors and expanders of working fluids which may be gases, dry vapours or multi-phase mixtures with phase changes taking place within the machine. They may operate as oil flooded, with other fluids injected during the compression or expansion process, or without any form of internal lubrication. Their designs may vary, depending on the choice of rotor proportions and profile, the number of lobes in each rotor and in the shape and size of their ports and openings. To obtain the best combination of these for a given application requires a set of well defined criteria governed by an optimisation procedure.

Such a procedure should include not only, the generation and optimisation of the rotor profile and clearance distribution, but also the housing ports, bearings, seals and the lubrication system if full advantage is to be derived from their potential and maximum performance gains are to be achieved.

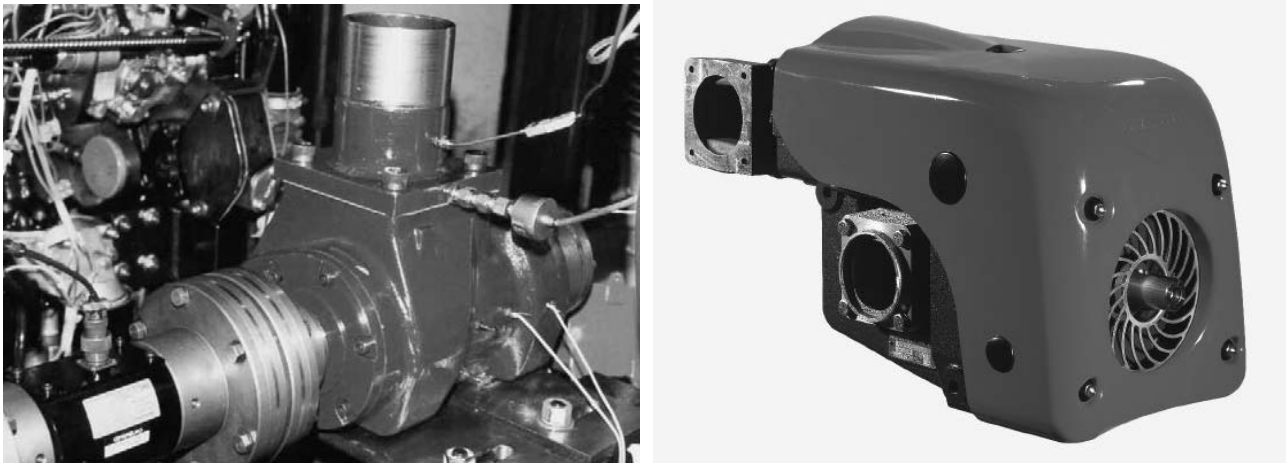

Figure 1 Typical examples of oil injected and dry screw compressors

This requires a complete understanding of the fluid flow inside the machine and at the inlet and outlet openings, the influence of the shape of compressor ports on the performance, the effects of high pressure and temperature gradients on the deformation of compressor elements and the reverse effects of these on the performance. Three dimensional CAD and CFD tools highly integrated with traditional computational tools for design and manufacture are thus being developed to evaluate these effects.

2. NUMERICAL ANALYSIS OF SCREW COMPRESSOR PROCESSES

Early designs of screw compressors were based on the assumption of an ideal gas in a leak proof working chamber going through a compression process which could reasonably be approximated in terms of pressure-volume changes by the choice of a suitable value of the exponent “n” in the relationship $pV^n = \text{Constant}$. The advent of digital computing made it possible to model the compression process more accurately and, as time passed, ever more detailed models of the internal flow processes were developed based on the assumption of one-dimensional flow.

2.1. One Dimensional models

The assumption of dimensionless non-steady bulk fluid flow and steady one dimensional leakage flow through the working chamber, together with suitable flow coefficients through the passages, and an equation of state for the working fluid, made it possible to develop a set of non-linear differential equations which describe the instantaneous flow of fluid, work and heat transfer through the system. These could be solved numerically to estimate pressure-volume changes through the suction, compression and delivery stages and hence determine the nett torque, power input, fluid flow and isentropic and volumetric efficiencies in a compressor. In addition, the assumption that any oil passed through the machine as a uniformly distributed spray with an attributed mean droplet diameter, enabled account to be taken of oil injection. Such models were then refined by comparing predictions, derived from them, with experimentally derived performance data.

A typical result of such modelling was the generation of a suite of computer programs called SCORPATH for the performance prediction and optimisation of screw compressors. More details of this are given in the recently published book on Screw compressor modelling and performance analysis by *Stosic et al, 2005*. Similar work was also carried out by other authors such as *Fleming and Tang 1998* or *Sauls, 1998*. Despite their speed and relatively accurate results, these works lacked the possibility for analysis of some important phenomena that affect compressor performance and reliability.

2.2. Three Dimensional Models

Screw compressor performance may be estimated more precisely by the use of Three-dimensional Computational Fluid Dynamics (CFD) or Computational Continuum Mechanics (CCM). Although the number of papers published in this area has increased recently, only a few deal with the application of computational fluid dynamics to screw compressors. These began with the work of *Stosic et al* in 1996. That paper gives basic principles of three dimensional numerical modelling applied to positive displacement screw machines.

However, it was not successful due to the relatively poor grid generation applied. *Kovačević, Stošić and Smith* published a number of papers between 1999 and 2005. These papers introduced 3-D numerical analysis to the screw compressor world. In later years, the authors published a series of papers related to both, grid generation in screw compressors and 3D numerical performance estimation. *Kovacevic et al, 2003 and 2005*. These include fluid solid interaction in screw machines, *Kovacevic et al, 2004*. A recent book on CFD in screw machines by *Kovacevic et al, 2006* give a comprehensive overview of the methods and tools used.

A number of commercial CFD software packages are currently available which may be able to cope with the complex flow through screw machines and be integrated with CAD systems. However developed these codes are, there are still limitations in their use for some applications. For the analysis of screw machines, a moving, stretching and sliding mesh has to be produced to map the working chamber. The grid generators contained in these packages are still not capable of coping with these requirements.

Computational Continuum Mechanics

Computational fluid dynamics (CFD) covers a broad area, which attracted the interest of many investigators at the beginning of the computer era. It is based on the numerical simulation of the conservation laws of mass, momentum and energy, derived for a given quantity of matter or control mass. Three main groups of methods have been developed through the years as described by *Ferziger and Perić, 1995*. These are the finite difference, finite element and finite volume methods. The finite volume method has been used for this application and is briefly described.

Of particular interest for the analysis of screw compressors is the calculation of unsteady flow with moving boundaries. The space conservation law introduced earlier and further discussed by *Demirdžić and Perić, 1988 and 1990*, allowed calculation in complex geometries and various grid topologies. Detailed analysis on pressure-velocity coupling, given by *Perić, 1990* and later discussed and improved by *Demirdžić et al, 1992* and *Demirdžić and Muzaferija, 1995* allowed application of the method simultaneously to fluid flow and solid body stress analysis.

The usual practice for the analysis of solid body deformation or fluid-structure interaction is to couple Finite Volume (FV) code with Finite Element (FE) solvers using a specially designed interface. Most CFD and FE vendors use that procedure to take advantages of both FV and FE. Although well established, this procedure in many situations may not be entirely suitable. One important example is the simultaneous conjugate heat transfer in both a solid and a fluid. This is the case of the interaction of fluid flow and solid deformation in a screw machine. However, this may be estimated by use of Computational Continuum Mechanics (CCM). In this case, the small deformation of solid parts is caused by the large pressure and temperature gradients, which are generated as a consequence of the fluid flow. Although these deformations are relatively small, they are of the similar order of magnitude as the compressor clearances, and may thus significantly change the leakage flow within the machine.

There are many CFD and FE codes currently available. However, the authors most commonly employ COMET, developed by Star CD, mainly because that was the first commercial code on the market that enabled simultaneous fluid flow and solid structure calculations. Today many CFD codes allow similar calculations and are integrated with CAD systems. Most of these today use a modern polyhedral topology of computational control volumes to map the geometry, as discussed in *Peric, 2004*. Polyhedral cells allow both easier grid generation and more accurate solution in a mesh with a lower number of cells. This improves the computational speed.

Grid Generation

Grid generation problems are mainly connected with computational fluid dynamics but the applicability of the concepts used in making numerical grids is not in any way limited to this area.

Applying the principles of analytical grid generation through transfinite interpolation with adaptive meshing, the authors have developed an automatic numerical mapping method for an arbitrary screw compressor geometry, as explained in *Kovacevic, 2005*. This was later used for the analysis of the processes in screw compressors. On that basis, the authors have developed an interface program called SCORG (Screw Compressor Rotor Geometry Grid generator), which also enables a grid, generated by the program, to be directly transferred to a commercial CFD or CCM code through its own pre-processor.

The interface employs a novel procedure to discretise rotor profiles and to adapt boundary points for each particular application so that the numerical mesh generated for the rotor domains is directly transferable to a Computational Fluid Dynamics or Computational Continuum Mechanics code. This is required to overcome problems associated with moving, stretching and sliding rotor domains and to allow robust calculations in domains with significantly different ranges of geometry features, *Kovacevic, 2006*. Stationary parts of the compressor domain can be generated either by use of a commercial grid generator or in SCORG and in any case they are directly integrated in the CFD or CCM code.

3. APPLICATION OF CAD SYSTEMS IN THE DESIGN OF SCREW COMPRESSORS

Both preliminary and detailed mechanical design in traditional CAD systems is limited to the representation of geometric data and other types of information relating to geometry. The implementation of the function, behaviour and structure of a specific machine cannot not be accounted for in them.

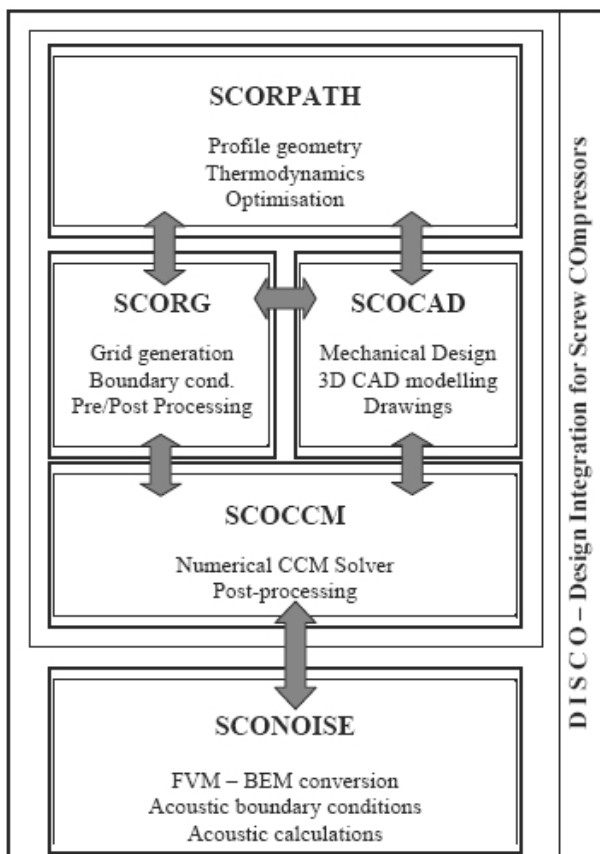

Figure 2 Organisational scheme of DISCO

The engineering design community has been developing new classes of tools to support knowledge-based design, product data management (PDM) and concurrent engineering. When contrasted with traditional CAD tools, these new systems are improved but are still mainly database related. Also, although these systems can represent some kinds of non-geometric information such as design process details, bills of materials, etc, the representation of the design object itself is still generally limited to geometric considerations. Evidence of this may be found by reviewing the projects described on the *IAI web page*. Due to these limitations, further interoperability is required to enable full interaction between any CAD system and performance estimation software.

CAD systems also relate to the selection and/or calculation of mechanical properties of compressor elements. Some are selected from standard databases such as bearings, bolts and screws, keys and key-ways, dowels etc., while others are designed and calculated for deflections and strength. The majority of CAD software allows such calculation through integrated CAE components. However, these generally require substantial action by the user in order to set up and relate loads and restraints, calculated outside the CAD system, with geometry created within the CAD system, as reported in *Kovacevic, 2004*.

4. INTEGRATION OF SCREW COMPRESSOR DESIGN SOFTWARE

A prerequisite for success in the highly competitive market of screw machines is ability to design, analyse and produce machines quickly. These activities need to be automated to be used by design engineers in industry.

However, a great obstacle to obtaining fast results by screw compressor design engineers was their inability to implement both geometric and non-geometric information quickly. Thus, what was required was a concurrent design process to perform an iterative procedure in the design phases so that the exchange of information between software elements could be performed several times. This had to be done through design integration package that increases interoperability.

The DISCO (Design Integration for Screw Compressors) software was developed to integrate tools for the design and manufacture of screw machine components in a user friendly environment suitable for industrial use. It manages both geometric and non geometric information transfer between the software components used.

These are related to the heat and fluid flow, optimisation parameters, boundary conditions and operational parameters that are organised so that the function, behaviour and structure integration is embedded in the code. The interface basically consists of five modules named SCORPATH, SCORG, SCOCAD, SCOCFD and SCONOISE. The organisational scheme of DISCO is given in Figure 2. More information can be found in Kovacevic, 2005.

5. EXAMPLES OF USE

5.1. Two stage oil injected compressor

Oil injected screw compressors have been used for air compression for a long time. Today, more than ever, their successful marketing is dependent on their efficiency being high. The task was given to find the best design of a family of two-stage air compressors with shaft input powers between 22 and 312 kW at 8 – 15 bars discharge pressure. The design of an efficient second stage for one of these units is described here.

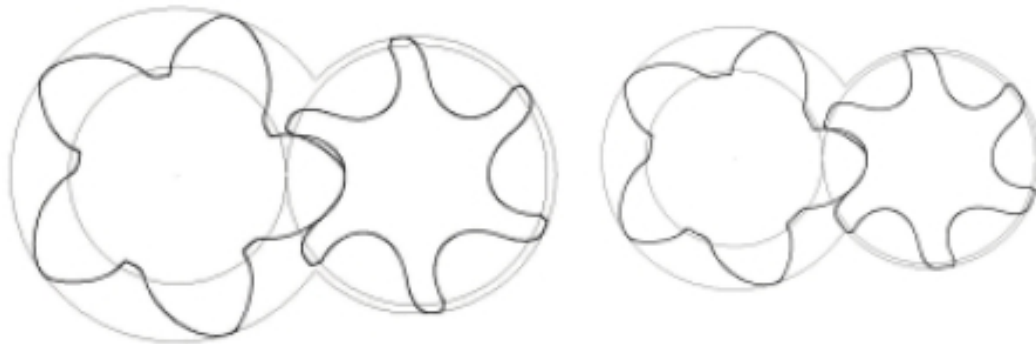

Figure 3 Rotor profiles optimised for a two-stage oil flooded screw compressor

Altogether 19 variables were used for this multivariable optimisation, 9 for each compressor stage plus the interstage pressure. Both 1st and 2nd stage rotors are presented in Figure 3, where it can be seen that there is a distinctive difference between them. The first stage rotors are slender to achieve high displacement, while the second stage rotors are stronger to survive the high pressure loads.

The computing time required to calculate the performance from the input data using this program is measured in tens of seconds while the whole optimisation process required less than one hour of computer time on an ordinary PC.

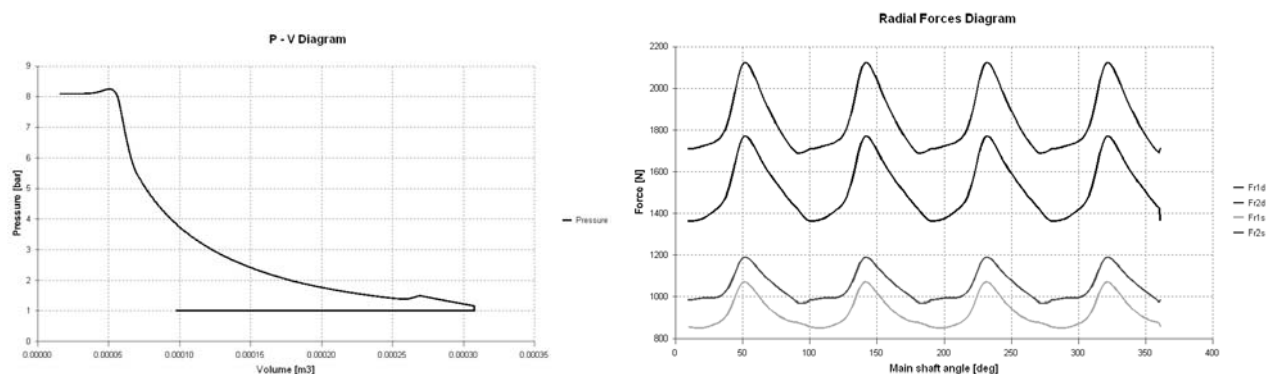

Figure 4 Performance calculation results

Diagrams generated directly from DISCO, presented in Figure 4, show the compressor performance and rotor bearing loads, obtained from the thermodynamic model as the basis for the calculation and selection of the compressor elements

The CAD model of the compressor is shown in Figure 5. This 3D solid model of the assembled compressor is generated directly in MDT 7 by use of a parameter database generated by SCOCAD. Since a fully parametric approach is applied during the entire integration with the CAD system the changes that had to be made are implemented directly and easily. Manufacturing drawings are generated from the 3D model. A part of the report on the calculation and selection of machine elements performed based on the forces calculated in SCORPATH, is presented in the same figure.

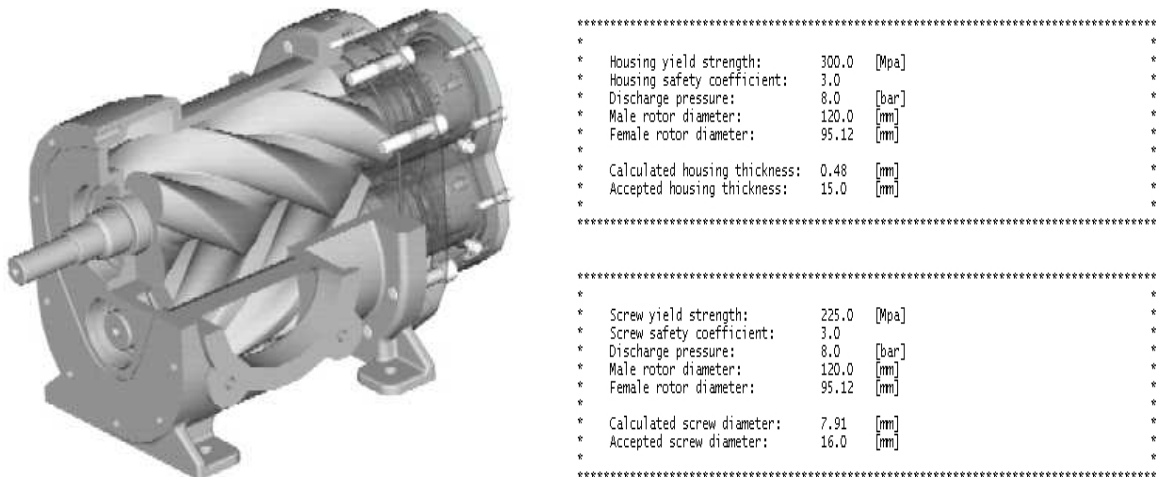

Figure 5 CAD Model of the compressor and the part of the report on housing thickness calculation

As the next step, the numerical grid for CCM calculations is generated by SCORG. The fluid and solid parts of the machine each contain about 700,000 numerical cells. A cross section through the fluid part of the mesh generated by SCORG is shown in the right hand side of Figure 6. The complete numerical mesh which includes suction and discharge ports is displayed in the left hand side of the same figure. The rotor domains are generated by SCORG, while the ports and other stationary mesh parts are generated by the commercial CAD-CFD interface Star-Works of CD-Adapco. The integration was performed fully automatically.

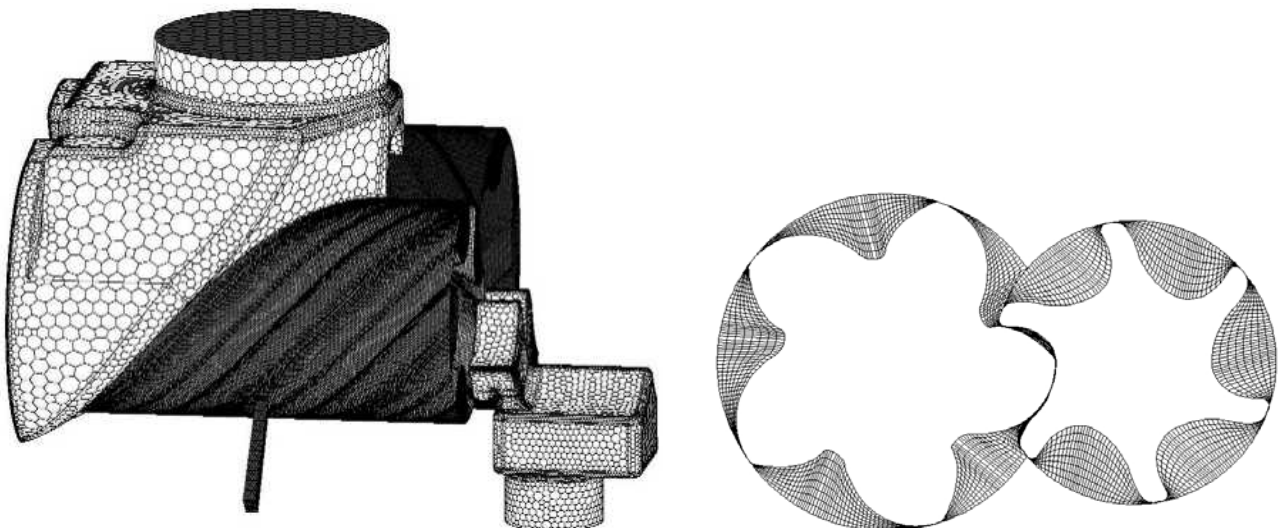

Figure 6 Numerical mesh for CCM calculation

With this number of cells, the numerical solution of fluid flow and rotor deformation was obtained on a PC by use of the COMET CCM solver in less than 30 hours. Here, it is important to emphasise the fact that the 3-D numerical simulation of fluid flow and structure analysis is used as a check rather than as an optimisation tool

because of the time required to obtain results for all the required 240 time steps. It is therefore performed only once at the end of the design process, before the prototyping of the machine.

The pressure and velocity distribution field obtained from the CCM calculation are presented on the left of Figure 7. The deformation of the male rotor is presented on the right of the same figure. The rotor distortions, which do not exceed 6 micrometers in this case, are magnified 20,000 times in order to be visible. The pressure distribution on the rotor surface is also given in the same figure. It is clear that the highest deformation is in the critical area of the machine but since it is not substantial, the leakage flow is practically unchanged and the performance is hardly affected by it.

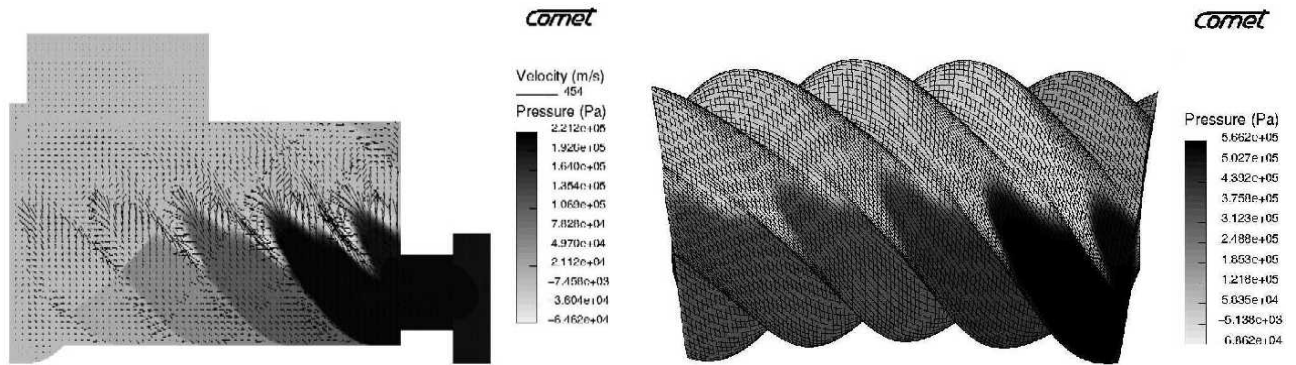

Figure 7 Distribution of pressure and velocity in the cross sectional view of the machine

5.2. Fluid solid interaction

Fluid and solid interaction is presented here for three common applications of screw compressors, each with the same geometry, as shown in Figure 8. These are: an oil-injected air compressor of moderate pressure ratio, a dry air compressor, of low pressure ratio, and a high pressure oil flooded compressor. In all cases, the rotors are of 'N' type with a 5/6 lobe configuration. The rotor outer diameters are 128 and 101 mm for the male and female rotors respectively, and their centre distance is 90 mm. The rotor length to diameter ratio is 1.65. The numerical mesh for the test case in this study comprises 513,617 cells of which 162,283 describe the solid part of the rotors, 189,144 other cells map the fluid parts between the rotors while the rest specify the suction and discharge ports and oil openings. A cross section through the mesh for the rotors and their fluid paths is presented in Figure 9.

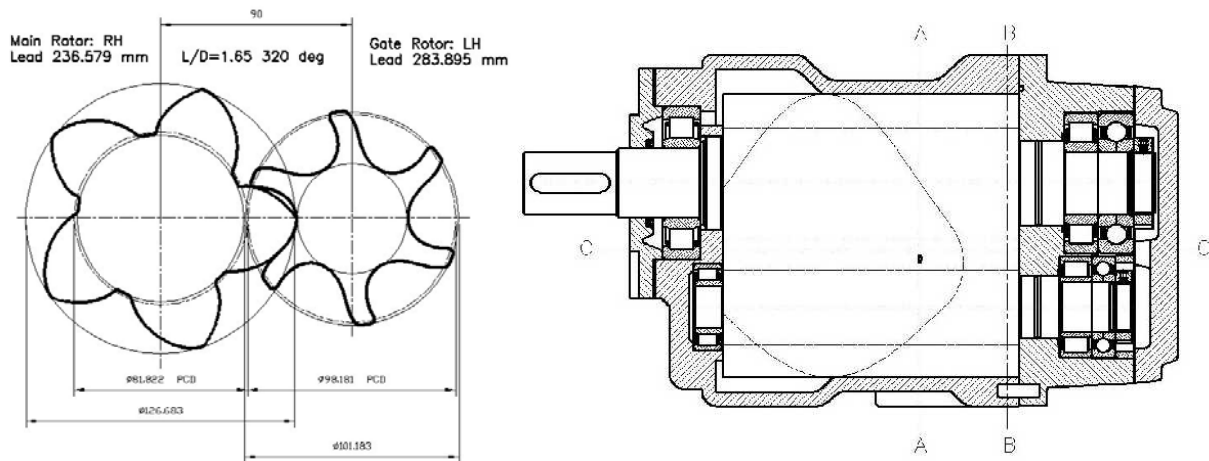

Figure 8 Cross section of rotors (left) and compressor (right)

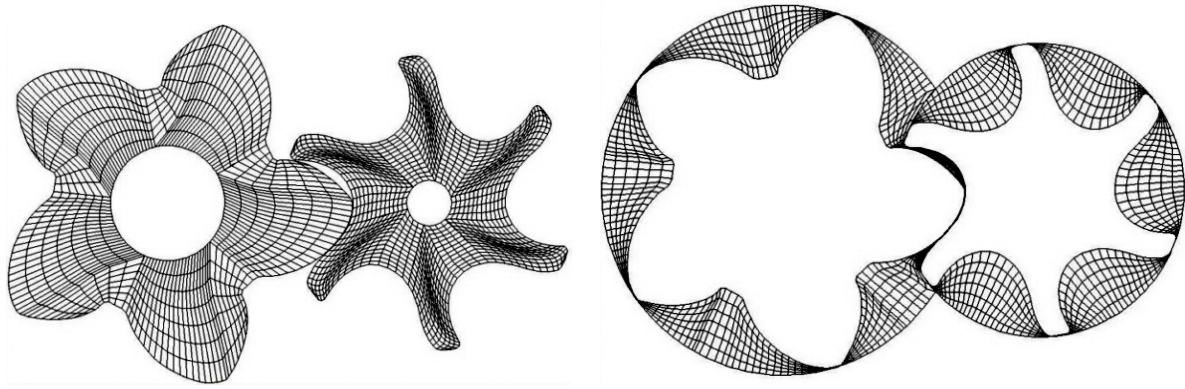

Figure 9 Numerical mesh for rotors (left) and their fluid parts (right)

The calculations were carried out on an office PC. A converged solution was achieved with 120 time steps in approximately 30 hours of computing time.

In the case of the oil injected air compressor, the results of the 3-D calculations were compared with measurements obtained from an experimental compressor of identical dimensions. The pressure fluctuations within the machine were measured with piezoresistive transducers, positioned in the male rotor side of the housing to cover as much as possible of the whole process. Measured results were obtained for suction conditions of 1 bar abs pressure and 20°C temperature with discharge pressures of 6, 7, 8 and 9 bar. Good agreement was obtained both for the instantaneous values, shown in the right diagram of Figure 10, and the integral parameters.

The rotor deformations caused mainly by the pressure rise in the working chamber are presented in the left diagram of Figure 10. These make the clearance gap between rotors larger. To make the results visible, the numerical grid deformations are enlarged 20,0 times.

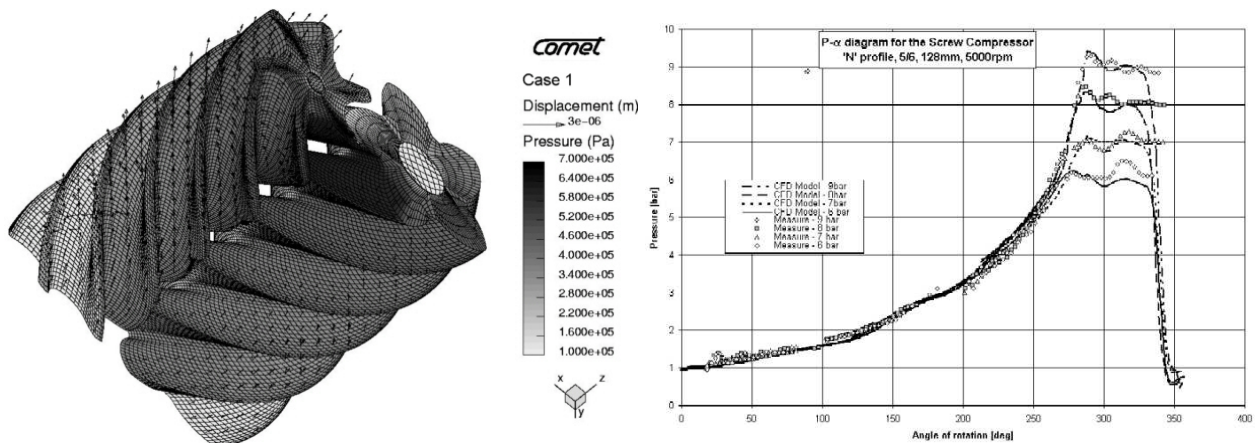

Figure 10 Rotor deformations (left), P- α diagram - comparison of CFD and measurements (right)

In the oil free air compressor, due to the lack of cooling oil, the air temperature rise is such that at 3 bar discharge pressure, the exit temperature has an average value of 180°C. The deformation in this case is presented in left Figure 11. The fluid temperature in the immediate vicinity of the solid boundary changes rapidly, as shown in the right diagram of the same figure. However, the temperature of the rotor pair is lower due to the continuous averaging oscillations of pressure and temperature in the surrounding fluid. This is shown in the right diagram of Figure 11, where the temperature distribution is given in cross section for both the fluid flow and the rotor body. The deformation, presented in the figure, is increased 1,500 times in order to make it visible. It has a maximum value of 50 μm .

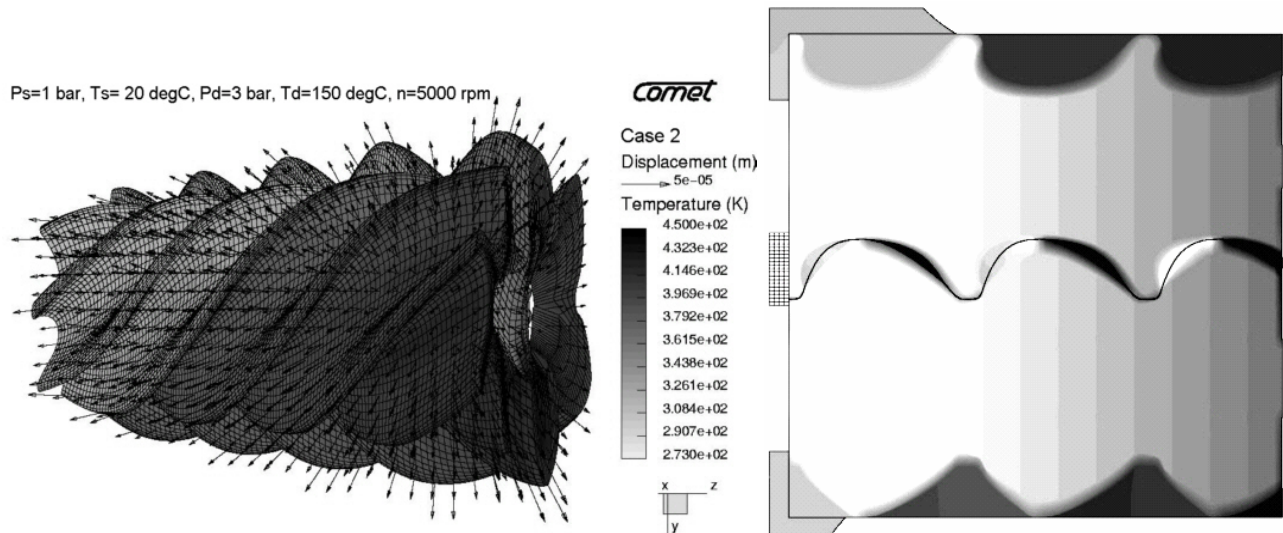

Figure 11 Rotor displacement vectors and temperature distribution for an oil free compressor

The high pressure oil injected application was taken as a CO₂ refrigeration compressor with suction conditions of 30 bar and 0°C and discharge conditions of 90 bar and 40°C. In this case, the large pressure difference was the main cause of the rotor deflection with the highest deformation in excess of 15 μm, as shown in Figure 12. The deformation pattern of the rotors is similar to the low pressure case but with slight enlargement at discharge.

The change of clearances caused by rotor deformation affects the compressor integral parameters, as shown in the right diagram of Figure 12. The reduced rotor clearance due to the temperature dilatation increases both the compressor flow and the power input. However, the effect on the flow is greater than on the power and hence the specific power decreases, or more conventionally, the efficiency is increased.

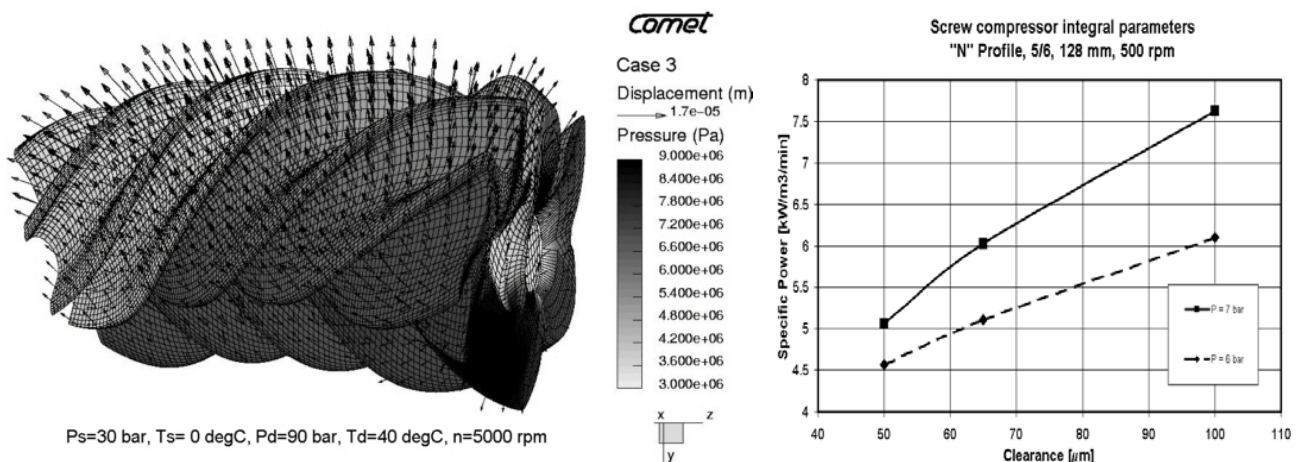

Figure 12 Deformations of a high pressure oil injected compressor

In other cases, rotor deflections caused by the pressure make the clearances larger. For a moderate pressure rise, the effect on delivery and power consumption is negligible. In the CO₂ refrigeration application, the rotors deform more and the decrease in delivery and rise in specific power becomes more pronounced.

5.3. Cavitation in a gear pump

The assembly, the functionality and the numerical mesh of a gear pump are presented in Figure 13. During operation, damage due to cavitation and erosion occurs at the rotor shafts and in the gaps. The work presented here is the property of CFX Berlin. *Steinman, 2006* outlined that the main challenges in this computation were the relatively complex geometry, the relative moving and deforming grids and transient interfaces and cavitation.

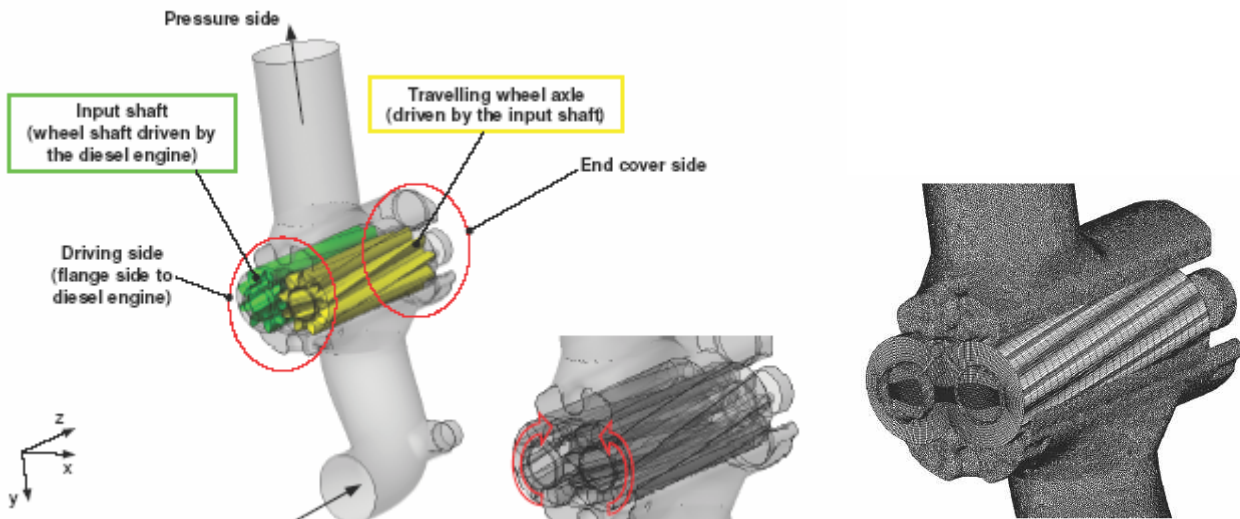

Figure 13 Geometry and numerical mesh of the gear pump

The hexahedral numerical mesh of moving parts was generated by SCORG while the stationary parts were meshed by ANSYS CFX and ICEM tools into a tetrahedral mesh. These two domains were connected through transient interfaces (GGI).

The pressure increase in the trapped volume is shown in the left of Figure 14. The iso-surface of the oil vapour volume fraction in the right figure represents the cavitation bubbles. Their movement in the near wall region causes the erosion induced by cavitation. The author concluded that cavitation is in phase with the period of the tooth meshing. Damage due to cavitation occurs likewise in the two axial gaps in terms of gap erosion as well as on the rotors on the trailing side of the flank.

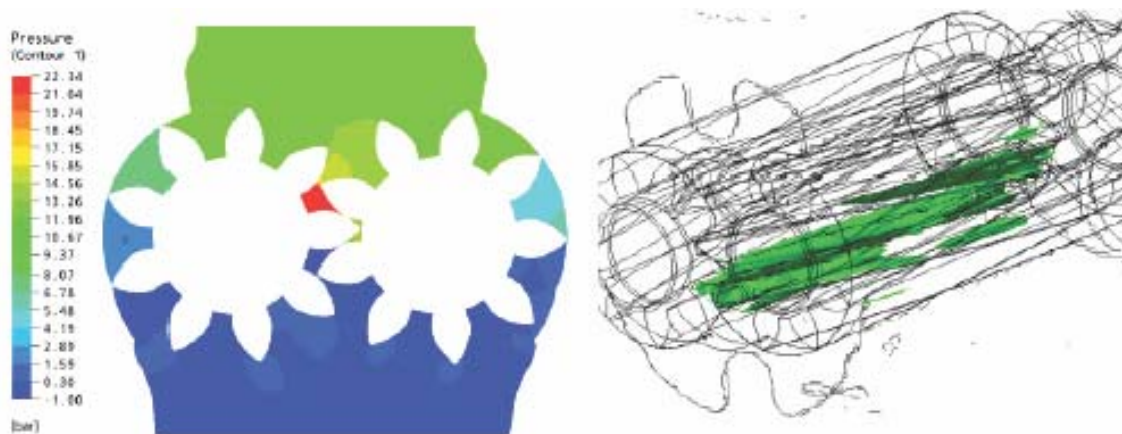

Figure 14 Pressure distribution in the gear pump (left) and the occurrence of cavitation (right)

5.4. Prediction of noise generation sources in screw machines

Noise identification and analysis in screw compressors have been an important issue in the majority of operations that involve such kinds of rotating machines for a long time. Here some details of ongoing research and development of methods to reduce noise emission from screw compressors is presented.

Pressure fluctuations in the discharge port affect not only aero acoustics in that domain but also a mechanically generated noise due to rotor rattling. Preliminary measurements of gas pulsations in an industrial compressor with different sizes of discharge port show the change in nature of the pressure oscillations in the port in Figure 15. It is believed that adequate porting can decrease the level of noise and increase the performance of the machine. A one dimensional thermodynamic method was derived which can estimate pressure oscillations as a function of the shape of the port and the cross sectional area of the connecting flange. These predictions agree reasonably well with the measured results. However, this model

does not take into account the shape of the discharge chamber which may play important role in the whole process.

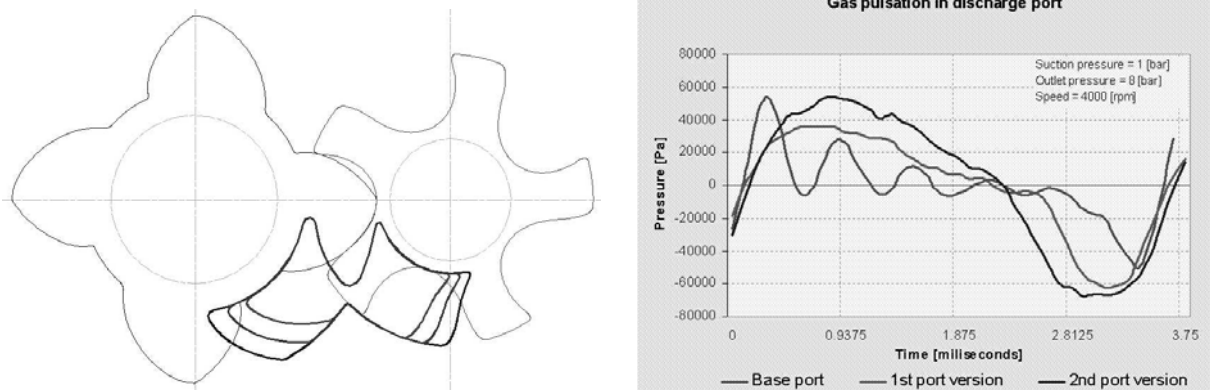

Figure 15 Measurements of pressure oscillations in the discharge port of an industrial compressor

Further steps are therefore undertaken to overcome this problem. Firstly, pressure fluctuations in the discharge port are calculated in the commercial CFD code. Hexahedral meshes are used to map moving rotor domains while a polyhedral mesh is generated from CAD-CFD interfaces for stationary domains. The left hand of Figure 16 shows the pressure oscillations obtained on dry compressor with a full 3D model of the entire compressor. This set of calculations required 240 time steps each of which took no more than 10 minutes of a normal PC time to obtain a converged solution. The results obtained by this model agree well with measurements, *Kovacevic, 2006*.

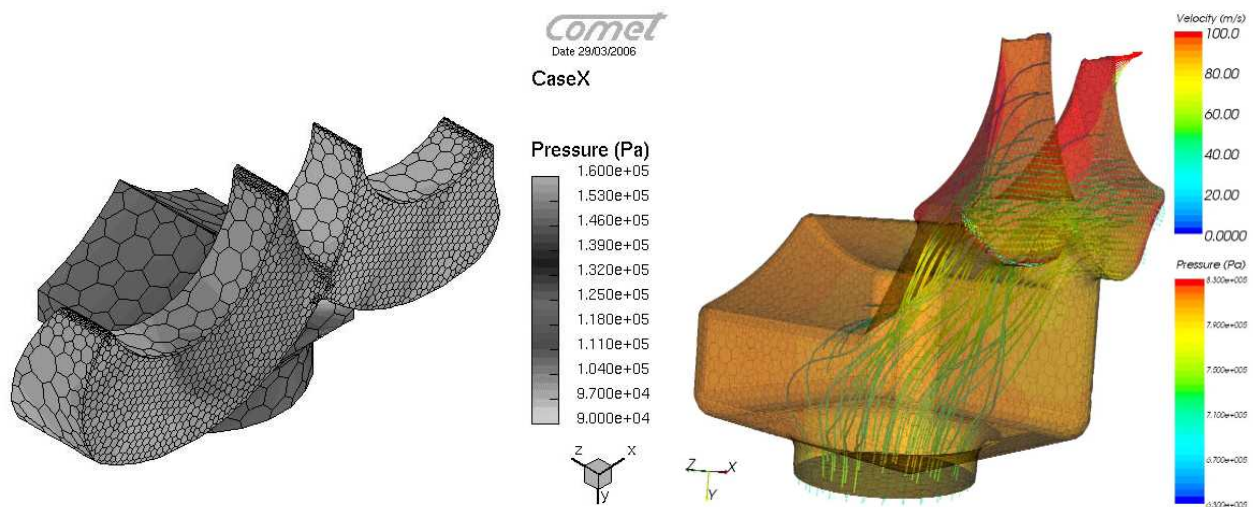

Figure 16 CFD calculation of blended 3D and 1D models (left) and results from the genuine 3D model (right)

Despite the accurate results, the speed of the calculation is still limiting factor for the application of this model in industry. It seems that 1D procedure which calculates pressure in the compression chamber when integrated with 3D CFD model in the novel commercial CFD code StarCCM+ might be a suitable option. Since the 1D chamber model runs as the user subroutine in CFD software it allows easy mapping of boundary conditions and fast overall calculations. The 3D CAD model is produced in DISCO for SolidWorks together with the macro for importing geometry and running the case. A polyhedral numerical mesh is in this case automatically generated for StarCCM+ by use of a commercial CAD-CFD interface developed by the CFD code vendor. The results of the numerical methods which blend 3D CFD analysis with 1D calculation of the compressor thermodynamics is presented on the left of Figure 16. The model could be generated in matters of minutes and it allows calculation of the entire compressor cycle in only a couple of hours on an ordinary PC.

CONCLUSIONS

The screw compressor is a mature product. Despite its now established role in industry, efforts continue to make advances in every aspect of its design, manufacture and mode of operation. Although improvements so gained are most likely to be evolutionary, there is still scope for revolutionary methods or procedures to achieve a better product. The new generation of methods and tools for the research and development of these machines give potential for the screw compressor to continue in use for a long time. Moreover, these tools can be used for other types of machine with a similar configuration to screw compressors and expanders such as gear pumps, multiphase pumps and vacuum pumps.

With the advent of computing technology, improvements in numerical methods and the interdisciplinary merging of analytical methods, an engineer is today in a position to design positive displacement machines faster and more accurately. Design Integration for Screw Compressors (DISCO) is tool which helps by the parametric merger of available CAD, CFD and other design tools.

ACKNOWLEDGEMENT

The authors wish to thank Dr A. Steinman of CFX Berlin for kind permission to publish part of his research on and analysis of a gear pump.

REFERENCES

- Demirdžić I, Muzaferija S, 1995: Numerical Method for Coupled Fluid Flow, Heat Transfer and Stress Analysis Using Unstructured Moving Mesh with Cells of Arbitrary Topology, Comp. Methods Appl. Mech Eng, Vol.125 235-255*
- Ferziger J H, Perić, M, 1996: Computational Methods for Fluid Dynamics, Springer, Berlin*
- Kovacevic A, Stosic N, Smith I. K, 2002: Solid-Fluid Interaction in Screw Compressors, XVI International Compressor Engineering Conference at Purdue, July 2002*
- Kovačević A, Stošić N, Smith I. K, 2003: Three Dimensional Numerical Analysis of Screw Compressor Performance, Journal of Computational Methods in Sciences and Engineering, vol. 3, no. 2, pp. 259- 284*
- Kovačević A, Stošić N, Smith I. K, 2004: A Numerical Study of Fluid-Solid Interaction in Screw Compressors, International Journal of Computer Applications in Technology (IJCAT), Vol. 21, No. 4, 2004, pp. 148-158*
- Kovačević A 2005: Boundary Adaptation in Grid Generation for CFD Analysis of Screw Compressors, International Journal for Numerical Methods in Engineering (IJNME), vol. 63, 2005*
- Kovačević A., Stošić N, Smith I.K, 2006: Screw Compressors Three Dimensional Computational Fluid Dynamics and Solid Fluid Interaction, ISBN-10: 3-540-36302-5 , Springer Berlin Heidelberg New York*
- Peric M.: "Flow simulation using control volumes of arbitrary polyhedral shape", ERCOFTAC Bulletin, No. 62, September 2004*
- Steinman A, 2006: Numerical Simulation of Fluid Flow in Screw Machines with Moving Mesh Techniques in ANSYS CFX," Schraubenmaschinentagung 2006", Dortmund VDI Berichte*
- Stošić N, Smith I. K. and Zagorac S, 1996: CFD Studies of Flow in Screw and Scroll Compressors, XIII Int. Conf on Compressor Engineering at Purdue*
- Stosic N, Smith, I.K. and Kovacevic, A, 2002: Optimization of Screw Compressor Design, XVI International Compressor Engineering Conference at Purdue, July 2002*
- Stošić N, Smith I.K, Kovačević A., 2005: Screw Compressors Mathematical Modelling and Performance Calculation, ISBN-10 3-540-24275-9, Springer Berlin Heidelberg New York*