



City Research Online

City St George's, University of London

Citation: Stosic, N., Smith, I. K. & Kovacevic, A. (2003). Rotor interference as a criterion for screw compressor design. *Journal of Engineering Design*, 14(2), pp. 209-220. doi: 10.1080/0954482031000091518

This is the accepted version of the paper.

This version of the publication may differ from the final published version. To cite this item please consult the publisher's version.

Permanent repository link: <https://openaccess.city.ac.uk/id/eprint/20590/>

Link to published version: <https://doi.org/10.1080/0954482031000091518>

Copyright and Reuse: Copyright and Moral Rights remain with the author(s) and/or copyright holders. Copies of full items can be used for personal research or study, educational, or not-for-profit purposes without prior permission or charge, unless otherwise indicated, provided that the authors, title and full bibliographic details are credited, a hyperlink and/or URL is given for the original metadata page and the content is not changed in any way. For full details of reuse please refer to [City Research Online policy](#).

ROTOR INTERFERENCE AS A CRITERION FOR SCREW COMPRESSOR DESIGN

N. Stosic, Ian K. Smith and A. Kovacevic

Centre for Positive Displacement Compressor Technology
City University, London, EC1V 0HB, U.K.
Tel: + 44 20 7477 8925
Fax: +44 20 7477 8566
E-mail: n.stosic@city.ac.uk

SUMMARY Rotor clearances are mainly responsible for screw compressor leakage. They must therefore be minimised in order to obtain high volumetric and adiabatic efficiencies of these machines. Continuing improvement in the rotor manufacturing equipment has enable tighter production tolerances to be achieved than was previously possible. Consequently, tolerances of other components, such as the rotor and bearing housings and the bearings themselves have to be included in the design process, in order to obtain the best possible overall performance.

A mathematical procedure to evaluate rotor interference in screw compressors due to bearing clearances and imperfections in the compressor housing manufacture is presented in this paper and has been used to evaluate how these affect screw compressor behaviour. It is shown that rotor interference resulting from the build up of these tolerances may affect the compressor when stationary as well as when rotating and may reduce the compressor efficiency, safety and reliability and also increase compressor noise. This simple, but effective method of quantification of the rotor interference can now be applied as a useful criterion in design of screw compressors.

1. Introduction

Screw compressors are positive displacement rotary machines comprising a meshing pair of helical rotors on parallel axes, contained in a casing. Together, these form a succession of working chambers whose volume depends on the angle of rotation.

An outline of the main elements of a screw compressor is shown in Fig. 1, which shows how the two rotors are contained in the casing. The main rotor, on the right, rotates counter clockwise, while the gate rotor, on the left, rotates clockwise. Admission of the gas to be compressed occurs through the low pressure surface portion on the bottom and rear face of the rotors while the gas is discharged mainly through the high pressure portion on the front face of the rotors. Exposure of the space between the rotor lobes to the suction port, as their front ends pass across it, allows the gas to fill the passage formed between them and the casing. Further rotation then leads to cut off of the port and progressive reduction in the trapped volume, thus causing the pressure of the trapped gas to rise. This leads to axial and bending forces on the rotors and also contact forces between the rotor lobes. The compression process continues until the required

pressure is reached when the rear ends of the passages are exposed to the discharge port through which the gas flows out at approximately constant pressure.

To perform effectively, screw compressor rotors must meet the meshing requirements of gears while maintaining a seal along their length to minimise leakage at any position on the band of rotor contact. It follows that the compressor efficiency depends on both the rotor profile and the clearances between the rotors and between the rotors and the compressor housing.

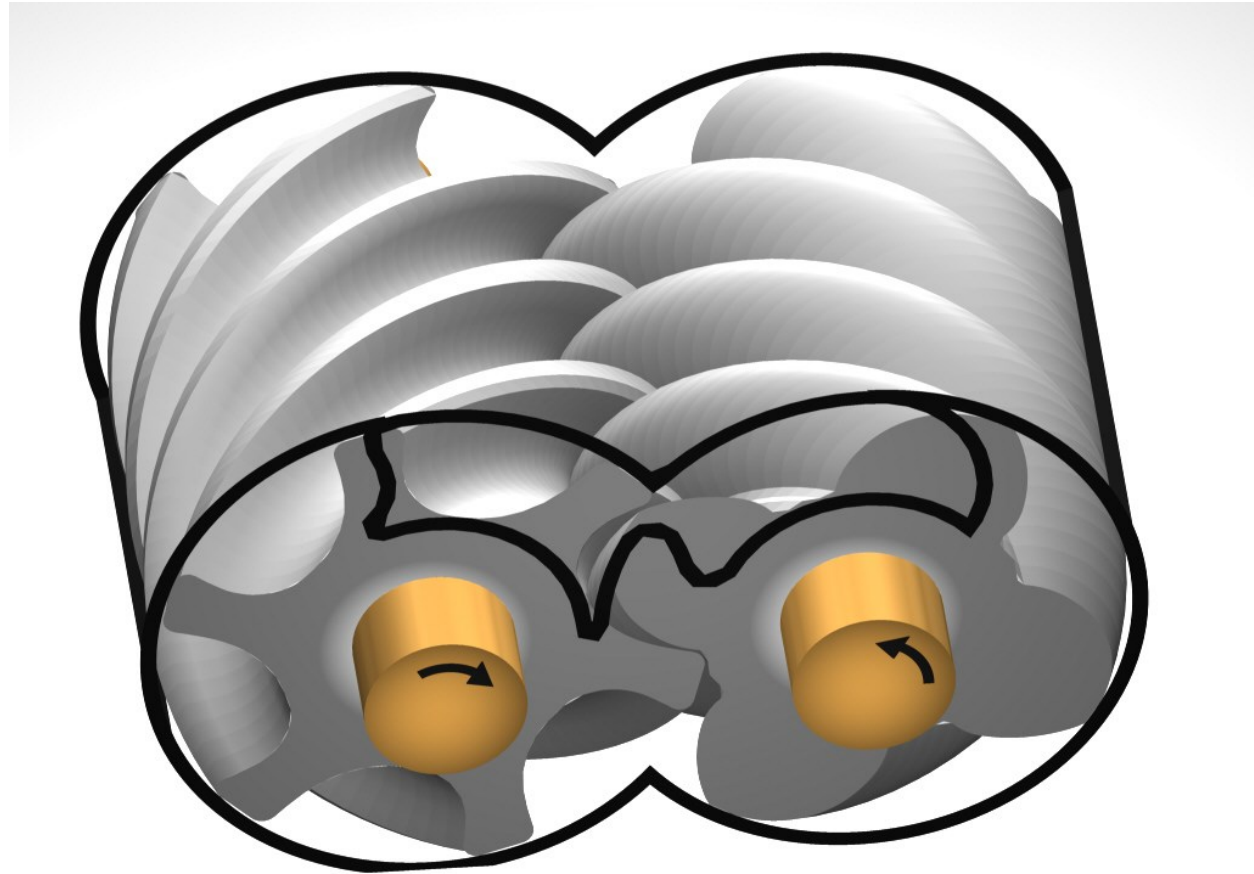

Fig 1. Screw compressor rotors in their casing

Screw compressor rotors are usually manufactured on specialised machines by the use of formed milling or grinding tools. Machining accuracy achievable today is high and tolerances in rotor manufacture are of the order of $5\ \mu\text{m}$ around the rotor lobes. *Holmes and Stephen, 1999* reported that even higher accuracy was achieved on the new Holroyd vitrifying thread-grinding machine, thus keeping the manufacturing tolerances within $3\ \mu\text{m}$ even in large batch production. This means that, as far as rotor production alone is concerned, clearances between the rotors can be as small as $12\ \mu\text{m}$.

To obtain the maximum possible advantage from such accuracy in rotor manufacture, the design and manufacture of all other components must be reviewed. Thus rotor to housing clearances, especially at high pressure must be properly selected. This in turn requires either precise bearings

with smaller clearances or looser bearings with their clearances reduced to an acceptable value by preloading. The latter practice is frequently chosen as the most convenient and economic solution.

Rotor axial and radial forces are transferred to the housing by the bearings. Rolling element bearings are normally chosen for small and medium screw compressors and these must be carefully selected to obtain a satisfactory design. Usually, two bearings are employed on the discharge end of each of the rotor shafts in order to absorb the radial and axial loads separately. Also, the distance between the rotor centre lines is in part determined by the bearing size and internal clearance. Any production imperfection in the bearing housing, like displacement or eccentricity, will change the rotor position and thereby influence the compressor behaviour.

A reliable procedure is required to analyse rotor movement within the range of the bearing clearances and manufacturing imperfections of the rotor and bearing housings. This will enable bearing clearance and housing manufacturing tolerance limits to be correctly specified in order to avoid rotor interference when inter lobe clearances are reduced to the levels now possible. The following approach is a simple and effective means of doing this.

2. Identification of Rotor Movement in Compressor Bearings

The system of rotors in screw compressor bearings is presented in Fig 2. The rotor shafts are parallel and their positions are defined by axes Z_1 and Z_2 .

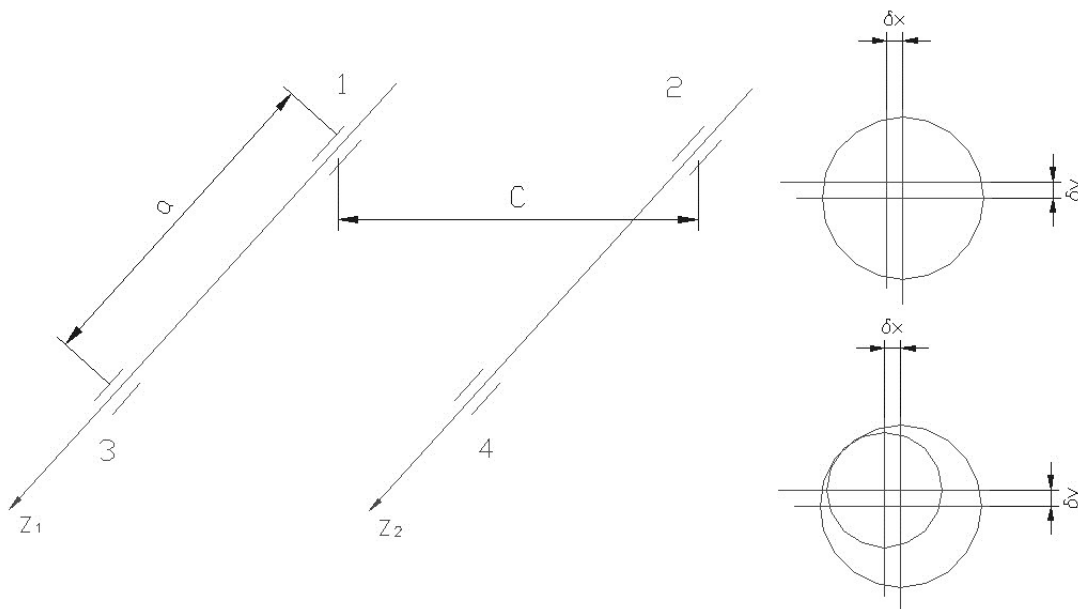

Fig 2. Rotor shafts in the compressor housing and displacement in bearings

The bearings are labelled 1 to 4, and their clearances, as well as the manufacturing tolerances of the bearing bores, δ_x and δ_y in the x and y directions respectively are presented in the same figure. The rotor centre distance is C and the axial span between the bearings is a.

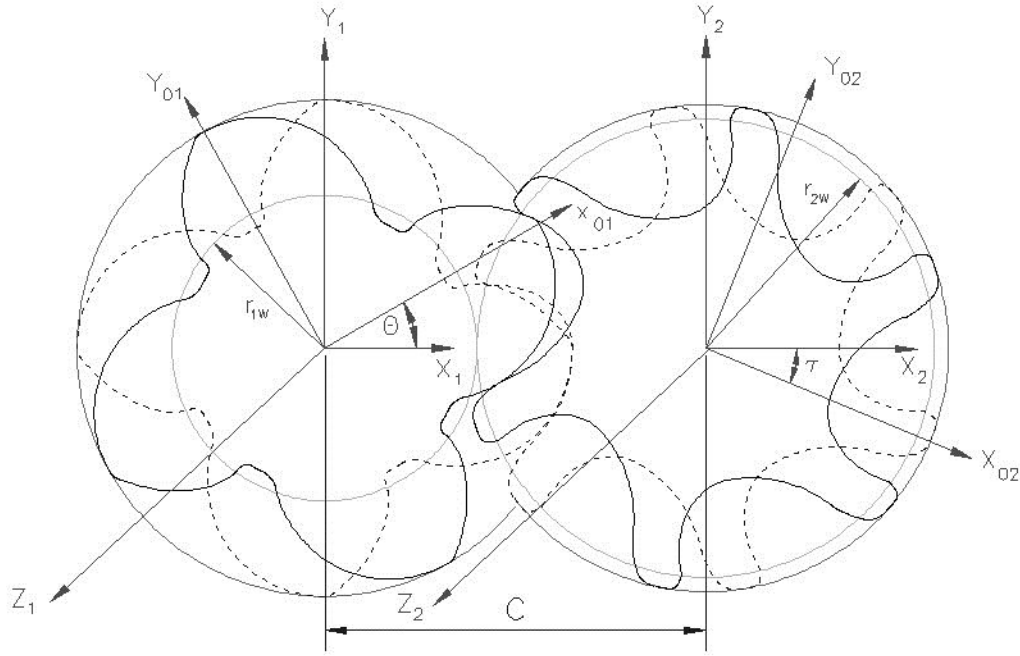

Fig 3. Rotors with parallel shafts and their coordinate systems

The envelope method for the analysis of gear motion has been described by *Litvin, 1994*. This is becoming increasingly popular, and details of how it may be applied to screw compressor rotor profiles, have been given by *Stosic, 1998*. In this procedure, vectors \mathbf{r}_1 and \mathbf{r}_2 represent the surfaces of rotor helicoids of the main and gate rotor respectively. X_{01} , y_{01} and x_{02} , y_{02} are the point coordinates at the end rotor section in the coordinate systems fixed to the main and gate rotors, as is presented in Fig 3. Equations (1) to (5) give the relation between the main and gate rotor point coordinates for a rotation angle θ , where p is the rotor lead per unit angle of rotation.

$$\mathbf{r}_1 = \mathbf{r}_1(t, \theta) = [x_1, y_1, z_1] = [x_{01} \cos \theta - y_{01} \sin \theta, x_{01} \sin \theta + y_{01} \cos \theta, p\theta] \quad (1)$$

$$\frac{\partial \mathbf{r}_1}{\partial t} = \left[\frac{\partial x_1}{\partial t}, \frac{\partial y_1}{\partial t}, 0 \right] = \left[\frac{\partial x_{01}}{\partial t} \cos \theta - \frac{\partial y_{01}}{\partial t} \sin \theta, \frac{\partial x_{01}}{\partial t} \sin \theta + \frac{\partial y_{01}}{\partial t} \cos \theta, 0 \right] \quad (2)$$

$$\mathbf{r}_2 = [x_2, y_2, z_2] = [x_1 - C, y_1, z_1] = [x_{02} \cos \tau - y_{02} \sin \tau, x_{02} \sin \tau + y_{02} \cos \tau, p\tau] \quad (3)$$

$$\frac{\partial \mathbf{r}_2}{\partial \tau} = [-y_2, x_2, 0] = [x_{02} \sin \tau + y_{02} \cos \tau, x_{02} \cos \tau - y_{02} \sin \tau, 0] \quad (4)$$

$$\left(\frac{\partial \mathbf{r}_1}{\partial t} \times \frac{\partial \mathbf{r}_1}{\partial \theta} \right) \cdot \frac{\partial \mathbf{r}_2}{\partial \tau} = 0 \quad (5)$$

Rotation of the rotor shaft is the natural rotor movement in its bearings. While the main rotor rotates through angle θ , the gate rotor rotates through angle $\tau=r_{1w}/r_{2w}\theta =z_2/z_1\theta$, where r_w and z are the pitch circle radii and number of rotor lobes respectively.

Andreev, 1961 and, more recently, *Xing, 2000*, also use the envelope method for screw compressor rotor generation in their books on screw compressors. A similar approach was applied by *Tang, 1995*.

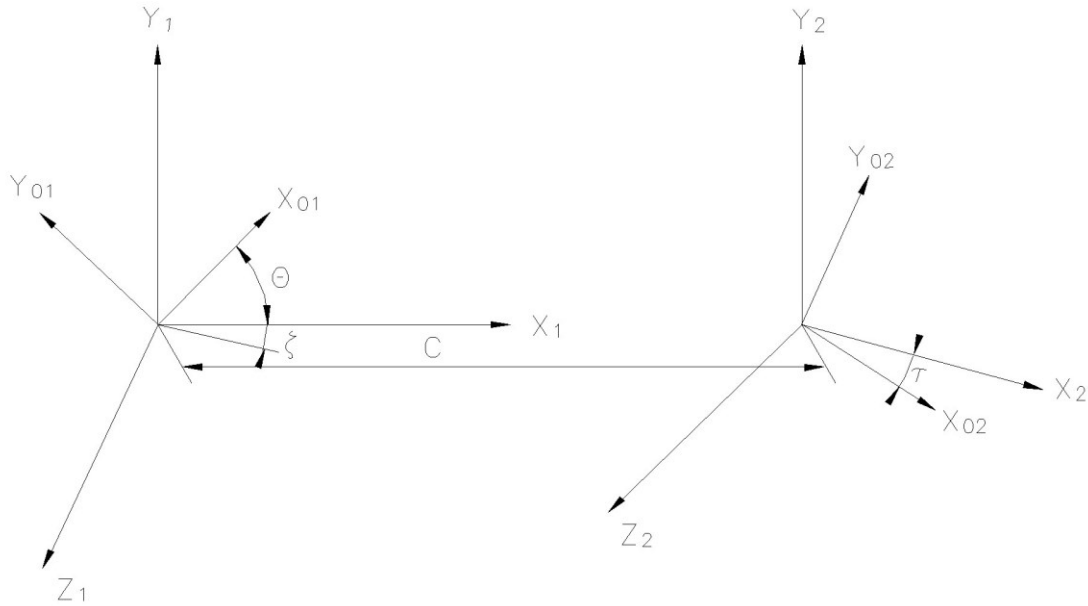

Fig 4. Rotors with intersecting shafts and their coordinate systems

All imperfections in the manufacture of screw compressor rotors should fall within and be accounted for by production tolerances. These are the wrong position of the bearing bores, eccentricity of the rotor shafts, bearing clearances and imperfections and rotor misalignment. Together, they account for the rotor shafts not being parallel. Let rotor movement δ_y in the y direction contain all displacements, which are presented in Fig 2, and cause virtual rotation of the rotors around the X_1 , and X_2 axes, as shown in Fig 4. Let rotor movement δ_x in the x direction cause rotation around the Y_1 , and Y_2 axes, as shown in Fig 5. The movement δ_x can cause the rotor shafts to intersect. However, the movement δ_y causes the shafts to become non-parallel and non-intersecting. These both change the nature of the rotor position so that the shafts can no longer be regarded as parallel. The following analytical approach enables the rotor movement to be calculated and accounts for these changes. It was first presented by *Stosic et al, 2001*.

As shown in Fig 4, vectors $\mathbf{r}_1=[x_1,y_1,z_1]$ and \mathbf{r}_2 , given in equation (6) now represent the helicoid surfaces of the main and gate rotors on intersecting shafts. The shaft angle ζ , given by (4) is the rotation about Y .

$$\mathbf{r}_2 = [x_2, y_2, z_2] = [x_1 \cos \zeta - z_1 \sin \zeta - C, y_1, x_1 \sin \zeta + z_1 \cos \zeta] \quad (6)$$

$$\operatorname{tg} \zeta = \frac{\delta_x}{a} \quad (7)$$

Since this rotation angle is usually very small, equation (6) can be rewritten in a simplified form as equation (8), which can be used more easily for further analysis.

$$\mathbf{r}_2 = [x_2, y_2, z_2] = [x_1 - z_1 \zeta - C, y_1, x_1 \zeta + z_1] \quad (8)$$

The rotation ζ will result in a displacement $-z_1 \zeta$ in the x direction and a displacement $x_1 \zeta$ in the z direction, while there is no displacement in the y direction. The displacement vector becomes:

$$\Delta \mathbf{r}_2 = [-z_1 \zeta, 0, x_1 \zeta] \quad (9)$$

In the majority of practical cases, x_1 is small compared with z_1 and only displacement in the x direction need be considered. This means that rotation around the Y axis will practically change the rotor centre distance only. Displacement in the z direction may be significant for the dynamic behaviour of the rotors. Displacement in the z direction will be adjusted by the rotor relative rotation around the Z axis, which can be accompanied by significant angular acceleration. This may cause the rotors to lose contact at certain stages of the compressor cycle and thus create rattling, which may increase the compressor noise.

Since the rotation angle ζ caused by displacement within the tolerance limits is very small, a two-dimensional presentation in the rotor end plane can be applied, as is done in the next section.

As shown in Fig 5, vectors $\mathbf{r}_1 = [x_1, y_1, z_1]$ and \mathbf{r}_2 , given by equation (10) now represent the helicoid surfaces of the main and gate rotors on the intersecting shafts. Σ is the rotation angle around the X axes given by (11).

$$\mathbf{r}_2 = [x_2, y_2, z_2] = [x_1 - C, y_1 \cos \Sigma - z_1 \sin \Sigma, y_1 \sin \Sigma + z_1 \cos \Sigma] \quad (10)$$

$$\operatorname{tg} \Sigma = \frac{\delta_y}{a} \quad (11)$$

Since angle Σ is very small, equation (10) can be rewritten in simplified form as equation (12), which facilitates further analysis.

$$\mathbf{r}_2 = [x_2, y_2, z_2] = [x_1 - C, y_1 - z_1 \Sigma, y_1 \Sigma + z_1] \quad (12)$$

The rotation Σ will result in displacement $-z_1 \Sigma$ in the y direction and displacement $y_1 \Sigma$ in the z direction, while there is no displacement in the x direction. The displacement vector can be written as:

$$\Delta \mathbf{r}_2 = [0, -z_1 \Sigma, y_1 \Sigma] \quad (13)$$

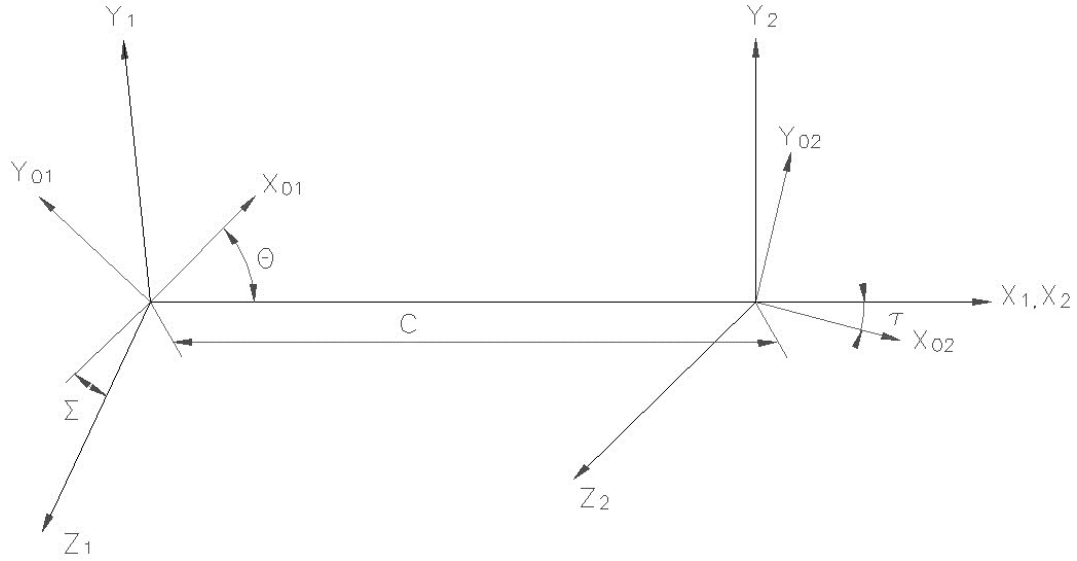

Fig 5. Rotors with non-parallel and non-intersecting shafts and their coordinate systems

Although, in the majority of practical cases, displacement in the z direction is very small and therefore unimportant for consideration of rotor interference, it may play a role in the dynamic behaviour of the rotors. The displacement in the z direction will be fully compensated by a regular rotation of the rotors around the Z axis. However, the angular acceleration involved in this process may cause rotors to lose contact at some stages of the compressor cycle.

Rotation about the X axis is effectively the same as if the main or gate rotor rotated relatively through angles $\theta = -z_1 \Sigma / r_{1w}$ or $\tau = z_1 \Sigma / r_{2w}$ respectively and the rotor backlash will be reduced by $z_1 \Sigma$. Such an approach substantially simplifies the analysis and allows the problem to be presented in two dimensions in the rotor end plane.

3. Rotor Interference Presented in the Rotor End Plane

Although the displacements described in this paper are entirely three-dimensional, a two-dimensional presentation of them in the rotor end plane section can be used for analysis.

Equation (3) serves to calculate both the coordinates of the rotor meshing points x_2, y_2 on the rotor helicoids and x_{02}, y_{02} in the end plane from the given rotor coordinates points x_{01} and y_{01} . It may also be used to determine the contact line coordinates and paths of contact between the rotors. The sealing line of screw compressor rotors is somewhat similar to the rotor contact line. Since there is a clearance gap between rotors, sealing is effected at the points of the most

proximate rotor position. A convenient practice to obtain a clearance gap between the rotors is to consider the gap as the shortest distance between the rotors in a section normal to the rotor helicoids. The end plane clearance gap can then be obtained from the normal clearance by appropriate transformation.

If δ is the normal clearance between the rotor helicoid surfaces, the cross product of the \mathbf{r} derivatives, given in the left hand side of equation (5), which defines the direction normal to the helicoids, can be used to calculate the coordinates of the rotor helicoids x_n and y_n from x and y to which the clearance was added as:

$$x_n = x + p \frac{\delta}{D} \frac{dy}{dt}, \quad y_n = y - p \frac{\delta}{D} \frac{dx}{dt}, \quad z_n = \frac{\delta}{D} \left(x \frac{dx}{dt} + y \frac{dy}{dt} \right) \quad (14)$$

where the denominator D is given as:

$$D = \sqrt{p^2 \left(\frac{dx}{dt} \right)^2 + p^2 \left(\frac{dy}{dt} \right)^2 + \left(x \frac{dx}{dt} + y \frac{dy}{dt} \right)^2} \quad (15)$$

The x_n and y_n serve to calculate new rotor end plane coordinates, x_{0n} and y_{0n} , with clearances from equations (1) and (3) for angles $\theta = z_n/p$ and τ respectively. X_{0n} and Y_{0n} now serve to calculate the transverse clearance δ_0 as the difference between them, as well as the original rotor coordinates x_0 and y_0 .

A 4/6 rotor pair is chosen as an example to present the rotor interference caused by imperfections in compressor manufacturing. The rotor centre distance is 75 mm and the outer rotor diameters are 99.00 and 93.36 mm for the main and gate rotors respectively. The rotor length is 153.5 mm and the unit lead is 25.24 mm/rad. The bearing span is 200 mm. There is assumed to be a uniform clearance between the rotors of 85 μm .

For the purpose of this analysis, the rotors are fixed in their suction bearings and the whole bearing displacement is applied to one of the discharge bearings. The aggregate displacement of all the bearings is $\delta_x = \delta_y = 50 \mu\text{m}$, which reduces the rotor centre distance by a maximum of 44 μm and imposes a rotation of 0.06° on the gate rotor.

Both the rotors, with their corresponding clearance distribution scaled by a factor of 50, are shown in figs 6-14.

As can be seen in Fig. 6, contact is established on the lower part of the rotor lobe at the rotor end close to the suction bearings. The rotor contact belt is somewhat too long on the main rotor round side, indicating that rotor seizure might occur in this area. The clearance distribution close to the mid span of the rotors is presented in Fig 7. It can be seen that the clearance around the rotor lobe is almost uniform. In Fig 8, the clearance distribution is presented at the discharge end of the rotors. The reduced backlash is visible in this position.

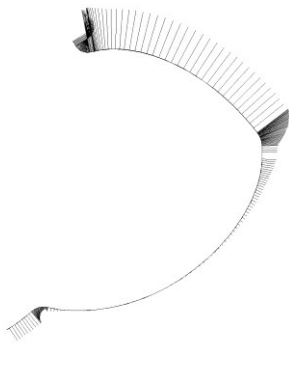

Fig 6. Clearance distribution between the rotors close to the rotor suction

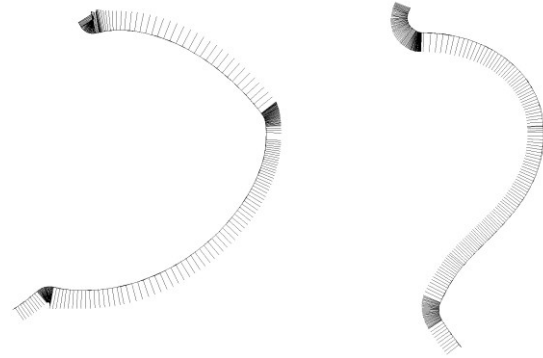

Fig 7. Clearance distribution near to mid of the rotors

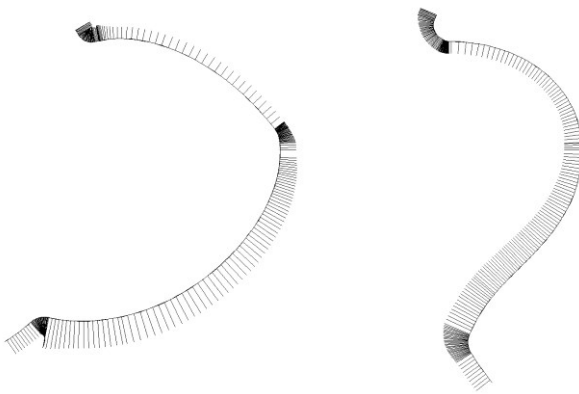

Fig 8. Clearance distribution between the rotors at the discharge rotor end

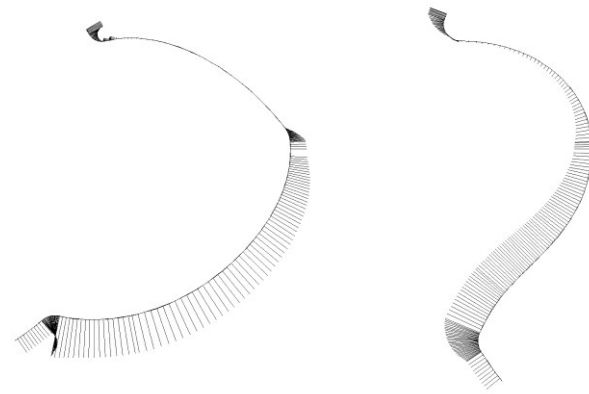

Fig 9. A possible clearance distribution at the discharge end

If by any means, the rotors change their relative position, the clearance distribution at the discharge end of the rotors may be reduced to zero at the flat side of the rotor lobes, as presented in Fig 9. In such a case, rotor contact will be prohibitively long on the flat side of the profile, where the dominant relative rotor motion is sliding. This indicates that rotor seizure will almost certainly occur in that region if the rotors come into contact with each other.

This situation indicates that a non-uniform clearance distribution should be applied to avoid hard rotor contact in rotor areas where sliding motion between the rotors is dominant. This requires 'non-conjugate' generation of the rotors.

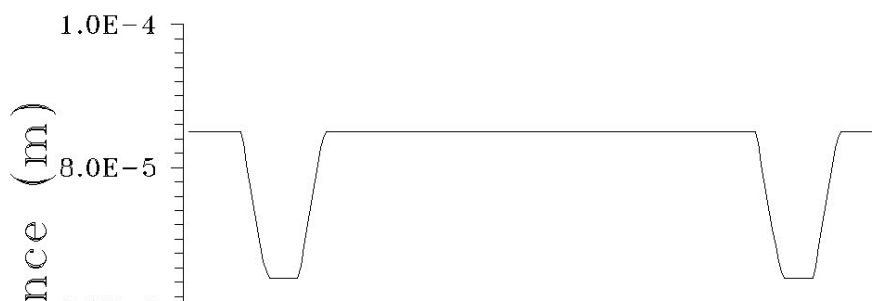

Fig 10. Variable clearance distribution applied to the rotors

In Fig 10, a reduced clearance of 65 μm is presented, which is now applied in rotor regions close to the rotor pitch circles, while in other regions it is kept at 85 μm , as was done by *Edstroem, 1992*. As can be seen in Figs 11-14, the situation regarding rotor contact is now quite different. This is maintained along the rotor contact belt close to the rotor pitch circles and fully avoided at other locations. It follows that if contact occurred, it would be of a rolling character rather than a combination of rolling and sliding or even pure sliding. Such contact will not generate excessive heat and could therefore be maintained for a longer period without damaging the rotors until contact ceases or the compressor is stopped.

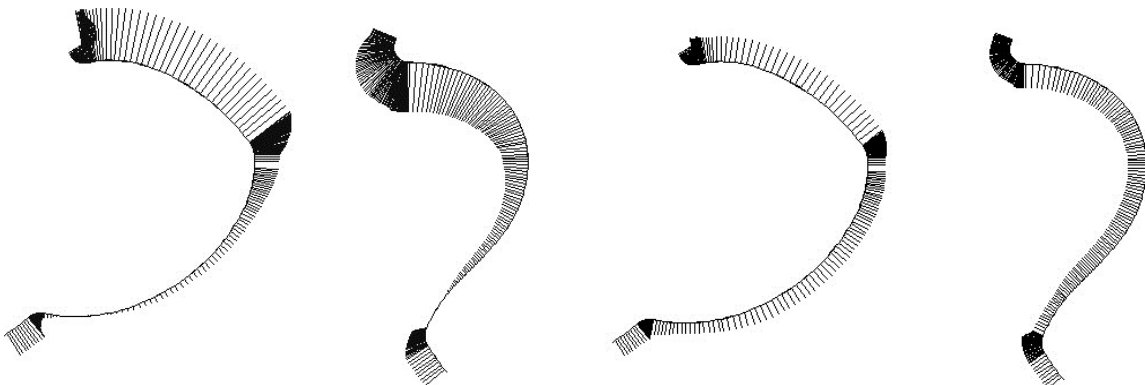

Fig 11. Clearance distribution between the rotors close to suction

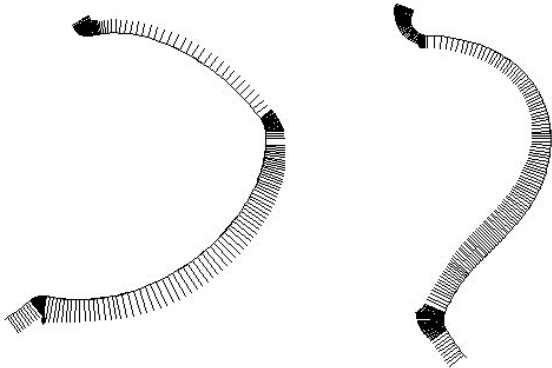

Fig 12. Clearance distribution near to mid of the rotors

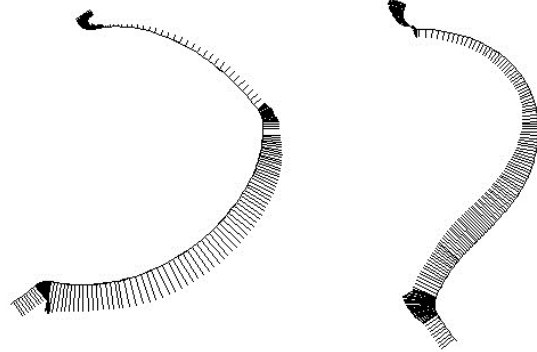

Fig 12. Clearance distribution between the rotors at the discharge

Fig 13. A possible clearance distribution at the discharge

4. Dynamic Effects of Rotor Interference

Apart from the static effects of rotor interference, which are described in the previous section, some dynamic effects may be caused by the incorrect rotor position in its housing. Two examples are related to oil flooded compressors.

The first example, presented here, is the non-uniform movement of the gate rotor caused by displacement of the rotor contact point in the z direction. Since such displacements as $x_1\zeta$ and $y_1\Sigma$, defined by Eqs. (7) and (11), are variable, they cause variable relative rotation of the rotors, which will result in a non-uniform movement of the gate rotor regardless of whether or not the rotors are conjugate. This will inevitably cause oscillations of the gate rotor and the eventual generation of rotor noise.

The second dynamic effect, which is mentioned here, is the intermittent contact of the main and gate rotors along the rotor length. It can be seen from Figs 6 and 11, that the necessary driving contact between the rotors is maintained only for a short length at the suction end of the rotors. By rotation of the rotors, this contact will soon terminate, leaving the gate rotor in a position to rotate freely until it again contacts the main rotor along the next rotor lobe. This will inevitably be connected with discontinuity of the gate rotor movement and its eventual impact with the main rotor, which may cause excessive noise and premature rotor wear.

6. Conclusions

Screw compressor rotors are manufactured today with very tight tolerances by formed grinding tools. This permits small rotor clearances, which leads to more efficient screw compressors. However, small rotor clearances cause production imperfections in the screw compressor housings and bearings, to have a far greater significance.

A simple mathematical analysis, derived in the paper, has been applied to quantify the static and dynamic effects of the rotor interference in screw compressors caused by the manufacturing imperfections of the screw compressor housings and bearings. This may be used as a design criterion to enable compressor manufacturers to choose tolerances for these components which enable the full performance benefits of high precision compressor rotors to be achieved in these machines without increased likelihood of noise or seizure.

REFERENCES

Andreev P. A, 1961: Vintovie kompressornie mashinii (Screw Compression Machines), SUDPROM Leningrad, Russia

Edstroem S. E, 1992: A Modern Way to Good Screw Compressor Rotors, International Compressor Engineering Conference at Purdue, 18

Holmes C. S. and Stephen A. C, 1999: Flexible Profile Grinding of Screw Compressor Rotors, International Conference on Compressors and Their Systems, IMechE London

Litvin F, 1994: Gear Geometry and Applied Theory, Prentice Hall, Englewood Cliffs

Stosic N, 1998: On Gearing of Helical Screw Compressor Rotors, Proc IMechE, Journal of Mechanical Engineering Science, Vol 212, 587

Stosic N, Smith I. K and Kovacevic A, 2001: Calculation of Rotor Interference in Screw Compressor, International Compressor Technique Conference, Wuxi, China

Tang Y, 1995: Computer Aided Design of Twin Screw Compressors, PhD Thesis, Strathclyde University, Glasgow

Xing Z. W, 2000: Screw Compressors: Theory, Design and Application, (in Chinese), China Machine Press, Beijing, China