



## City Research Online

### City, University of London Institutional Repository

---

**Citation:** Chamney, M. J., Van Waeleghem, J. P., Lindley, E. and Pancírová, J. (2008). Venous needle dislodgement: how to minimize the risks. *Journal of Renal Care*, 34(4), pp. 163-168. doi: 10.1111/j.1755-6686.2008.00047.x

This is the accepted version of the paper.

This version of the publication may differ from the final published version.

---

**Permanent repository link:** <http://openaccess.city.ac.uk/5111/>

**Link to published version:** <http://dx.doi.org/10.1111/j.1755-6686.2008.00047.x>

**Copyright and reuse:** City Research Online aims to make research outputs of City, University of London available to a wider audience. Copyright and Moral Rights remain with the author(s) and/or copyright holders. URLs from City Research Online may be freely distributed and linked to.

---

City Research Online:

<http://openaccess.city.ac.uk/>

[publications@city.ac.uk](mailto:publications@city.ac.uk)

---

## **Venous needle dislodgement: how to minimize the risks**

### **Abstract**

Although haemodialysis (HD) has become a routine treatment, adverse side effects, and occasionally life threatening clinical complications, still occur. Venous needle dislodgment is one of the most serious accidents that can occur during HD. If the blood pump is not stopped, either by activation of the protective system of the dialysis machine or manually, the patient can bleed to death within minutes.

Fatal and near-fatal blood loss due to venous needle dislodgement (VND) have been described in the literature (ECRI 1998, Sandroni 2005, Mactier and Worth 2007), but published reports represent only the tip of the ice berg, as such incidents are normally handled at a local or national level.

The European Dialysis and Transplant Nurses Association/ European Renal Care Association (EDTNA/ERCA) has produced twelve practice recommendations to help reduce the risk of VND and detect blood leakage as early as possible. A poster summarising these recommendations has been created (Van Waelegem et al 2008).

### **Practice recommendations**

#### **1. *Staff, patients and carers should be aware of VND and the consequences***

The first practice recommendation is that staff, patients and carers should be aware of the possible consequences of VND. Educating and informing patients and carers must be a fundamental role of renal nurses.

#### **2. *An area around the vascular access large enough for taping should be cleaned and dried before cannulation***

Routine washing of the skin using soap and water is a simple and effective procedure that both reduces the possibility of vascular access infection and prepares the skin for taping.

Disinfection is the next step. It is essential to respect the time between application and cannulation required for the product used to obtain maximal efficiency and to allow the skin to dry.

In patients with very excessive hair growth, it may be advisable to shave the area around the puncture sites to ensure secure taping of the needles.

**3. *Haemodialysis units should have a consistent procedure for taping needles and blood lines***

All staff should use the same taping technique, as well as the same materials, where possible. Use of standard taping procedure makes it easier for staff to identify insecure initial fixation and any movement of the tape during dialysis.

For elbow or upper arm fistulae with deep arterialized veins, the use of longer needles (30 to 35 mm) may allow the fistula to be accessed at an angle that makes taping and securing the needles easier.

In exceptional circumstances, where the patient has unusual anatomy or is allergic to the materials normally used, a customised technique should be agreed by the nursing team.

For taping the needles, the 'butterfly' or 'chevron' technique is widely recommended by expert nurses. Figure 1 shows an example of this taping technique. The materials used will vary between units, but there should always be a chevron of tape to anchor the needle against any tugging on the tubing.

**4. *Blood lines should be looped loosely to allow movement of the patient and to prevent blood lines pulling on the needles***

The technique used to secure the blood lines plays an important role in preventing VND. Blood lines always should be looped loosely to allow the patient to move without the blood lines pulling on the needles.

Blood lines should never be fixed to the dialysis chair or bed, or to cushions, as movement of the patient or the equipment could result in needle dislodgement (Lindley et al 2005).

**5. *If it is necessary to reposition a needle, all taping should be replaced***

When repositioning a needle during dialysis, the old tape should be discarded and completely replaced with new tape.

**6. *Staff to patient ratio should be adequate to allow routine monitoring of vascular access during treatment***

There should always be enough staff on duty to allow regular checks to be made of the vascular access and the connections between the needle (or catheter) tubing and the blood lines. Additional checks should be made when patients change position. Patient to staff ratio differs between countries and units and should depend on the dependency and stability of the patients. An EDTNA/ERCA Research Board study found that the mean ratio was 4 patients (3.5 to 4.2) per nurse (Elseviers et al 2006).

While an ideal patient to staff ratio cannot be defined, staff management must be able to identify the point at which routine assessments such as surveillance of access during haemodialysis is impossible due to the number of patients and/or their clinical profiles.

**7. *All patients should be assessed for level of risk of VND and, if appropriate, an alarm device intended for monitoring venous needle dislodgement used***

Although all haemodialysis patients with an AV fistula or AV graft are at risk of VND, for most patients the risk can be minimized by secure taping and routine monitoring. For patients with a significantly higher risk of VND, the use of continuous monitoring using an appropriate blood leak detector should be considered.

Staff need to identify patients who need to be more closely monitored, whether via observation or an alarm device, at each treatment session. Risk factors that should be considered when assessing patients include:

- a) Restless patients including patients who have frequent side effects during haemodialysis such as hypotension and muscle cramps
- b) Patients with some degree of dementia
- c) Patients who are not fully conscious, and also very quiet (often elderly) such as patients who do not speak up when something is wrong.
- d) Patients with small blood leakage along the venous needle (this could be due to proximal stenosis, central venous stenosis or a high dose of heparin)
- e) Patients with difficult access (such as deep angle of cannulation, difficult location of access)

- f) Patients with excessive hair and patients prone to sweating (such as diabetics in case of hypoglycaemia)
- g) Patients who are allergic to the standard tape used to secure the needles
- h) Patients who consistently ignore the need to keep their vascular access uncovered (for example by pulling a blanket over it)
- i) Patients who dialyse alone and/or overnight

**8. *Vascular access and needles should be visible at all times during haemodialysis***

Keeping the vascular access and needles visible at all times allows staff to make routine checks without disturbing the patients. It also means that if VND does occur, it is more likely to be detected by the patient or staff before serious blood loss occurs.

Transparent covers that allow the needle positions to be viewed, rather than standard dressings or pads, should be used in haemodialysis units that prefer to cover the puncture sites.

Alarm devices, if used, should not cover the vascular access in a way that reduces the visibility of the needle positions.

**9. *When the venous pressure alarm is activated, the vascular access and fixation of needles and bloodlines should always be inspected prior to resetting the alarm limits***

If the venous pressure alarm is activated, it is essential that the vascular access is inspected to ensure that the needles are still correctly positioned before restarting the blood pump and resetting the alarm limit. If the venous pressure has dropped due to needle dislodgement, resetting the alarm limits will allow the machine to continue to pump blood out of the patient and into the environment.

**10. *The lower limit of the venous pressure alarm should be set as close as possible to the current venous pressure***

If VND occurs, the venous pressure alarm will only be activated if the resulting pressure drop takes the pressure below the lower limit of the alarm window. The venous pressure is a measure of the force required to push the dialysed blood through the extracorporeal circuit and back into the vascular access. Most of the pressure is

required to pump the blood through the needle, especially when the needle has a small internal diameter and when a high blood flow is used.

When an AV fistula (or AV graft) is functioning well with no significant stenosis the pressure in the access is low. As the contribution to the venous pressure made by pushing the blood into the access is normally relatively small, it is important to set the lower limit as close as possible to the current reading without causing an unreasonable number of false alarms. This is easier if the window is 'asymmetric', so that the limits can be set at, for example, -30 and +70 mmHg. This will reduce the number of spurious high venous pressure alarms due to movement etc. Staff should insist that new machines have the option to set an asymmetric alarm window. Machine manufacturers should ensure that the 'factory' setting (i.e. the initial default setting) for the low venous pressure alarm window is no wider than 30 mmHg.

***11. Staff, patients and carers should be aware that the venous pressure monitoring system of the dialysis machine will often fail to detect VND***

Even when the alarm limits are set as described above, the machine cannot be relied on to detect VND. The drop in venous pressure may be too small to activate the alarm because the access pressure is too low or because the needle is incompletely dislodged or obstructed by material covering the needle sites.

***12. Additional protection can be provided by devices intended to detect blood loss to the environment***

For patients at high risk of VND, additional protection can be provided by devices that can detect blood loss to the environment. In the past, particularly for nocturnal home HD, enuresis (bed-wetting) monitors have been used. Anecdotal evidence suggests that blood leakage can be detected by enuresis monitors (Lindley et al 2005) though they have not been tested and approved for this purpose. In-vitro tests have shown that these devices may fail to respond to volumes of up to 250ml blood (Sandroni 2008). The variation in reliability may be due to the brand or the maintenance of the monitor used.

Recently, a device that uses fibre optic technology to detect blood has been approved (CE marked) as a Class I medical device with the intended purpose of detecting venous needle dislodgement in extracorporeal circuits (Ahlmén et al 2008). The single-use sensor patch is placed over the venous needle site where it will absorb

blood if the needle is dislodged. When blood comes into contact with the patch it allows light to leak out of the optical fibre loop inside. The battery operated alarm unit detects a reduction in the intensity of light transmitted through the fibre and gives an audible and visual alarm. It is also capable of signalling to the dialysis machine, though currently no machines have the facility to accept an external blood leak detector. Other detection systems may be under development.

Ideally, any device used to detect VND should be linked to the dialysis machine so that the blood pump can be switched off when the alarm is activated. Machine manufacturers should be encouraged to develop the technology to enable this.

## **Conclusion**

Minimizing the risk of venous needle dislodgement requires a combination of human skills and vigilance and technology. Effective education, secure taping, regular monitoring and appropriate setting of the venous pressure alarm limits will reduce the risk of VND to an acceptable level in the great majority of patients.

For the small minority of patients who are assessed to be at high risk, and for whom sufficient observation is impractical, devices intended to detect blood loss to the environment can be used to ensure that an alarm is raised if VND occurs.

Industry should be encouraged to help optimise the technological solutions by providing machines with asymmetric venous pressure alarm windows that default to give a low venous pressure alarm limit close to the current setting, and by developing systems to allow built-in or external VND detectors to stop the blood pump.

## **Acknowledgements**

The recommendations and supporting text were produced by Jean-Pierre Van Waeleghem, Melissa Chamney, Elizabeth Lindley and Jitka Pancirova on behalf of the EDTNA/ERCA Educational and Research Board.

EDTNA/ERCA would like to thank Lesley Dinwiddie, Robert Mactier, Stephen Sandroni, John Sedgewick and David Worth for their input and ideas; Hans Polaschegg for his technical insights; Anne Budenberg and the staff at Wakefield Dialysis Unit for their taping pictures; and Anna Marti i Monros, Wim Van Biesen and Raymond Vanholder for reviewing the poster and supporting text on behalf of the ERA-EDTA European Renal Best Practice (ERBP) Advisory Board.

We would also like to thank Susanne Olausson and Patrik Byhmer from RedSense Medical AB for their support in the development and printing of the poster.

### **Conflict of interest declaration**

This project is supported by an educational grant from RedSense Medical.

Whilst the support received from RedSense Medical is a potential conflict of interest, EDTNA/ERCA considered it acceptable due to the shared goal of raising awareness of the risk of venous needle dislodgement. Currently RedSense Medical is the only company manufacturing an approved medical device intended for detection of VND but where monitoring for blood leakage is deemed to be necessary, the recommendations would apply to any product that is approved for detection of VND in future.

### **References**

Ahlmén J, Gydell KH, Hadimeri H et al. (2008) A new safety device for hemodialysis. *Hemodial International* 12, 264-7.

ECRI (1998) Undetected Venous Line Needle Dislodgment during Hemodialysis. *Health Devices* 27, 404-6

Elseviers M, De Vos J-Y, Harrington M et al. Comparison of Renal Care Practice in Europe: Centre and Patient Characteristics. *EDTNA/ERCA Journal* 32, 8-13.

Lindley EJ, James R, Wright G et al. (2005) Summary of the EDTNA/ERCA Journal Club discussion: Summer 2005. *EDTNA/ERCA Journal* 31, 220-7. Available on-line at [http://www.edtnaerca.org/pages/education/journalclub/summary2005\\_2.php](http://www.edtnaerca.org/pages/education/journalclub/summary2005_2.php) (accessed 20/08/2008)

Mactier R and Worth D. (2007) Minimising the risk of venous needle dislodgement during haemodialysis. *UK Association of Renal Technologists Newsletter* 41. Available on-line at [www.artery.co.uk](http://www.artery.co.uk) via link in Document Index (accessed 20/08/2008)

Sandroni S. (2005) Venous needle dislodgement during haemodialysis: An unresolved risk of catastrophic haemorrhage. *Hemodialysis International* 9, 102-103. Extended abstract available at [http://www.edtnaerca.org/pdf/education/JC\\_Sandroni2005.doc](http://www.edtnaerca.org/pdf/education/JC_Sandroni2005.doc) (accessed 20/08/2008)



Sandroni S, Sherockman T and Hays-Leight K. (2008) Catastrophic hemorrhage from venous needle dislodgement during hemodialysis: continued risk of avoidable death and progress toward a solution. To be published in the 2008 *American Society of Nephrology* Conference Proceedings.

Van Waeleghem J-P, Chamney MJ, Lindley EJ et al. (2008). Venous needle dislodgement (VND): How to minimize the risks. Recommendations for renal nurses. Poster available for download at [www.edtnaerca.org](http://www.edtnaerca.org) .

**Figure 1. Securing needles using the 'chevron' taping technique**

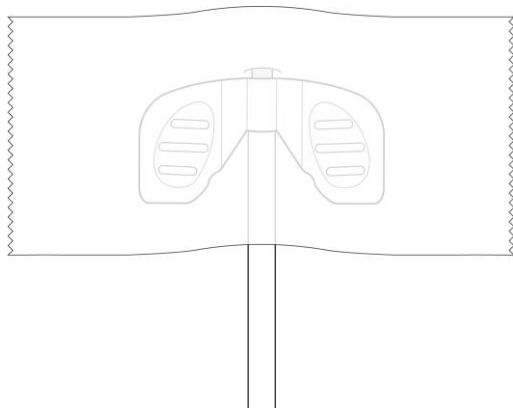

The needle is fixed in place by a rectangle of adhesive fabric (such as Mefix, Mölnlycke Health Care).

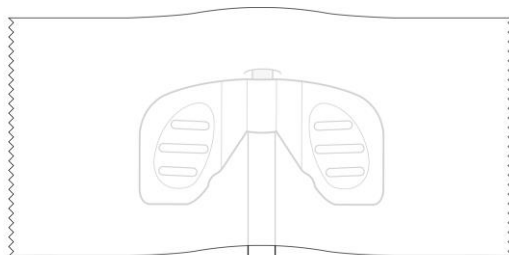

The tape (such as Millipore, 3D) used to make the chevron is positioned under the needle tubing close to the adhesive fabric with the sticky side facing up.

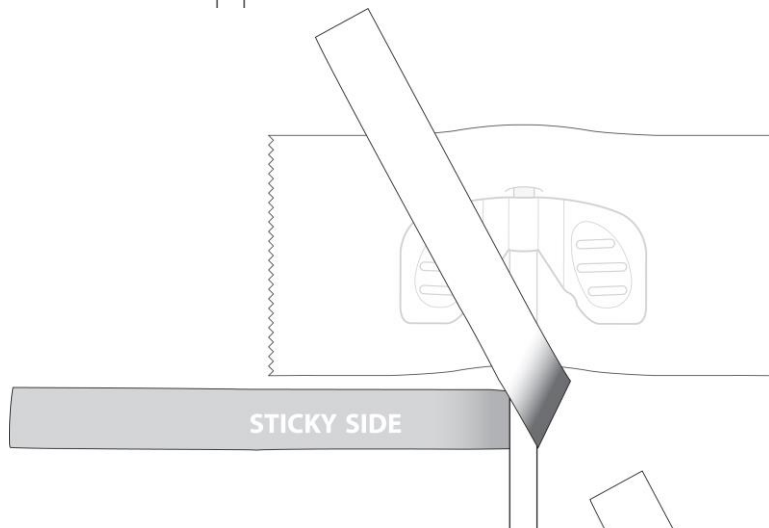
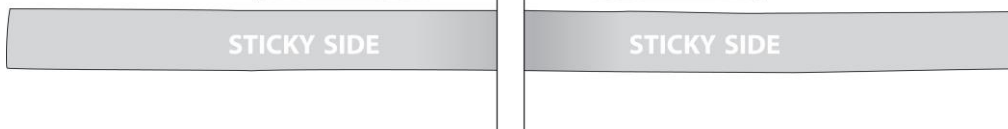

The ends of the tape are then crossed over to form the 'chevron' which helps secure the wings of the needle and resists tugging on the needle tubing.

