



## City Research Online

### City, University of London Institutional Repository

---

**Citation:** Kyriacou, P. A., Pal, S. K., Langford, R. and Jones, D. P. (2006). Electro-optical techniques for the investigation of oesophageal photoplethysmographic signals and blood oxygen saturation in burns. *Measurement & Control*, 39(3), pp. 77-79. doi: 10.1177/002029400603900302

This is the accepted version of the paper.

This version of the publication may differ from the final published version.

---

**Permanent repository link:** <http://openaccess.city.ac.uk/14688/>

**Link to published version:** <http://dx.doi.org/10.1177/002029400603900302>

**Copyright and reuse:** City Research Online aims to make research outputs of City, University of London available to a wider audience. Copyright and Moral Rights remain with the author(s) and/or copyright holders. URLs from City Research Online may be freely distributed and linked to.

---

City Research Online:

<http://openaccess.city.ac.uk/>

[publications@city.ac.uk](mailto:publications@city.ac.uk)

---

# **Electro-optical techniques for the investigation of oesophageal photoplethysmographic signals and blood oxygen saturation in burns**

P A Kyriacou<sup>1</sup>, S K Pal<sup>2</sup>, R M Langford<sup>3</sup> and D P Jones<sup>4</sup>

<sup>1</sup>School of Engineering and Mathematical Sciences, City University, London, UK

<sup>2</sup>St Andrew's Centre for Plastic Surgery & Burns, Broomfield Hospital, Chelmsford, Essex,

<sup>3</sup>Anaesthetic Laboratory & Department, St.Bartholomew's Hospital, London, UK

<sup>4</sup>Medical Electronics & Physics, Department of Engineering, Queen Mary University of London, London, UK

## **Executive summary**

*Pulse oximetry is widely used in anaesthesia and intensive care monitoring. It is a valuable, non-invasive optical monitoring technique used for continuous measurement of arterial blood oxygen saturation ( $SpO_2$ ). Sites for pulse oximeter sensors are frequently difficult to find in patients with major thermal injury. Therefore blood oxygen saturation readings are often unobtainable at just the time when they would be most valuable. An oesophageal  $SpO_2$  probe has been designed to record reliable photoplethysmographic (PPG) signals and  $SpO_2$  values from the oesophagus of burned patients. Seven adult patients were studied. Good quality oesophageal PPG signals with large amplitudes were measured from various depths within the oesophagus. The optimal monitoring oesophageal depth ranged from 13 cm to 20 cm, measured from the upper lip. It was found that the oesophageal pulse oximeter saturation results were in good agreement with those from the CO-oximeter. This study suggests that the*

*oesophagus can be used as an alternative site for monitoring arterial blood oxygen saturation by pulse oximetry in burned patients.*

## **Introduction**

Non-invasive continuous arterial blood oxygen saturation measurement by pulse oximetry is widely acknowledged to be one of the most important technological advances in clinical monitoring<sup>1</sup>. Pulse oximeters are routinely used to monitor patients in anaesthetic rooms, operating theatres, recovery rooms and intensive care units. However, sites for pulse oximeter sensors are frequently difficult to find in patients with major thermal injury. Standard sites such as fingers or toes may be affected by the burn, unsuitable due to the use of tourniquets during surgery, or in some cases absent. Therefore blood oxygen saturation (SpO<sub>2</sub>) readings are often unobtainable at just the time when they would be most valuable.

Pulse oximeters estimate arterial blood oxygen saturation by shining light at two different wavelengths, red and infrared, through vascular tissue. In this method the pulsatile photoplethysmographic (AC PPG) signal associated with cardiac contraction is assumed to be attributable solely to the arterial blood component. The amplitudes of the red and infrared AC PPG signals are sensitive to changes in arterial oxygen saturation because of differences in the light absorption of oxygenated and deoxygenated haemoglobin at these two wavelengths. From the ratios of these amplitudes, and the corresponding DC photoplethysmographic components, arterial blood oxygen saturation (SpO<sub>2</sub>) is estimated. Hence, the technique of pulse oximetry relies on the presence of adequate peripheral arterial pulsations, which are detected as photoplethysmographic (PPG) signals<sup>2</sup>.

Studies have shown that measurable PPG signals and SpO<sub>2</sub> values can be detected in the oesophagus of healthy adult patients during anaesthesia and patients undergoing cardiothoracic surgery<sup>3-8</sup>. The present study was aimed at evaluating the reliability of oesophageal pulse oximetry in major burns patients.

## Materials and Methods

A reflectance electro-optical oesophageal pulse oximetry probe comprising miniature infrared (880 nm) and red (655 nm) emitters and a photodetector has been constructed (Figure 1). The silicon diode photodetector is mounted between the red and infrared emitters to detect radiation back scattered by the tissue. A separation of 5 mm between the emitters and the photodetector provides good signal-to-noise ratio and adequate pulsatile signals. The probe was designed to fit into a conventional disposable transparent gastric tube, 20 French gauge, which is sealed at the distal end<sup>6</sup>.

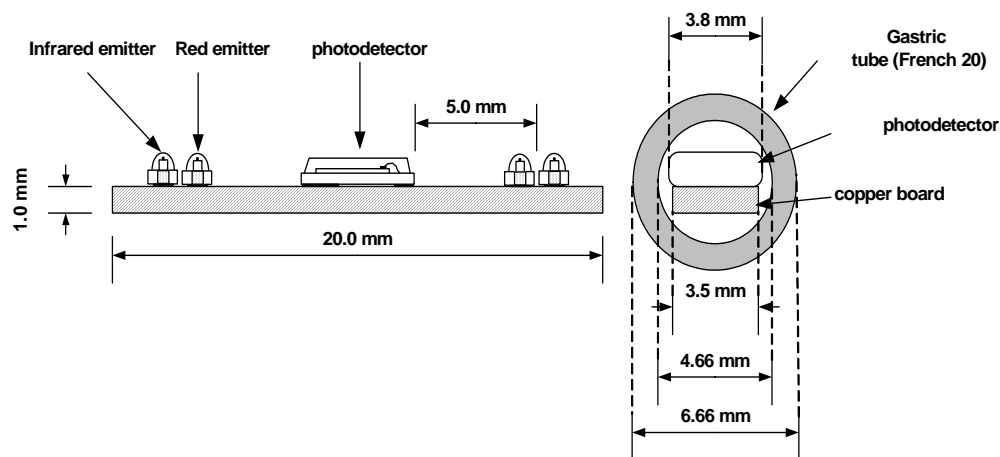

**Figure 1:** Side and cross sectional view of the reflectance electro-optical oesophageal pulse oximetry probe. In the cross sectional view the probe is shown inserted in the gastric tube

An isolated data acquisition and processing system, shown in Figure 2, has been developed to detect, process, record and display the red and infrared AC and DC PPG signals and estimate SpO<sub>2</sub> values from the oesophagus.

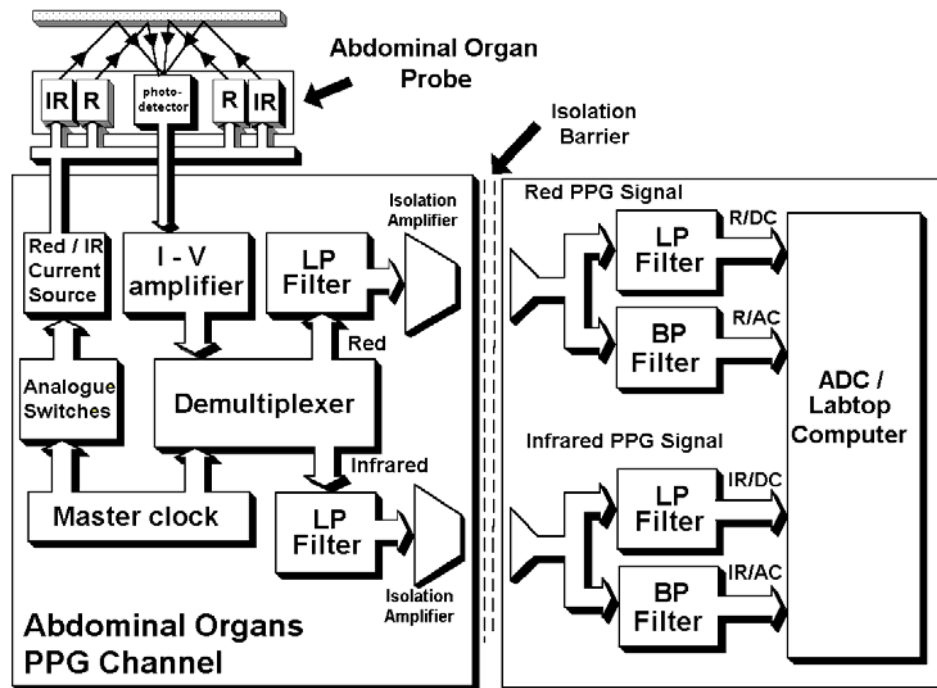

Figure 2: Block diagram of the oesophageal pulse oximetry processing system

The emitters, red (R) and infrared (IR), are driven by constant current sources which are controlled by analogue switches which turn the red and infrared emitters on and off at 75 Hz. The photodetector detects the energy backscattered by the tissue and gives an output current proportional to the detected light intensity. The output of the current-to-voltage (I-V) amplifier contains multiplexed PPG signals corresponding to red and infrared wavelengths. The signal from the current-to-voltage amplifier passes to a demultiplexer synchronised to the master clock, which separates the red (R) and infrared (IR) signals. The two signals (R and IR) are then passed through low pass filters to eliminate high-frequency switching transients and are then transmitted across an isolation barrier. Two isolation amplifiers (Burr-Brown ISO122) are used to isolate the patient side of the PPG channel from the output side. The

signals on the output side are then filtered to extract the AC and DC PPG components for each wavelength. The output signals are digitised using a 16-bit analogue-to-digital card (ADC) (National Instruments DAQCard-AI-16XE-50) and further analysed by a virtual instrument implemented in *LabView* on a laptop computer. PPG traces corresponding to infrared and red wavelengths from the oesophagus are obtained simultaneously and displayed on the laptop screen.

Following Local Research Ethical Committee approval and after obtaining informed, written consent, seven patients with major burns admitted to burns intensive care were recruited for the study. The five men and two women ranged in age between 26 and 52 years. The total body surface area burnt ranged between 28% and 90%. A nasogastric tube containing the reflectance pulse oximetry sensor was placed in each patient's oesophagus (Figure 3). The PPG signals were recorded at various depths in the oesophagus. Arterial blood samples were taken for estimation of oxygen saturation using a CO-oximeter. A peripheral commercial pulse oximeter saturation probe was also connected to the toe of each patient.

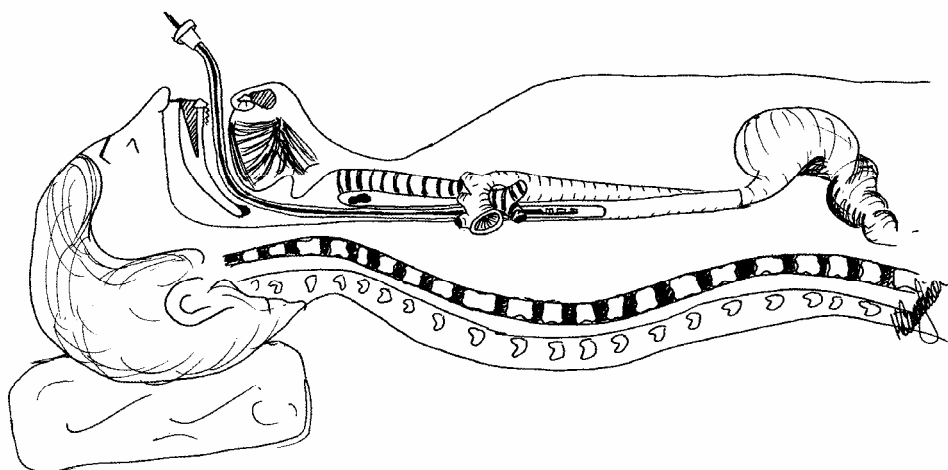

Figure 3: The oesophageal PPG/SpO<sub>2</sub> probe contained within the stomach tube is seen placed in the oesophagus via the mouth

Linear Regression analysis was used to compare the blood oxygen saturation results from the oesophageal pulse oximeter with those from CO-oximetry. It has been suggested that Linear Regression analysis is appropriate when calibrating an approximate or simple method (like the oesophageal pulse oximeter) with a precise method (such as CO-oximetry)<sup>9</sup>. A Bland and Altman *between-method differences* analysis was performed to calculate the levels of agreement between the oesophageal and commercial finger probes<sup>9</sup>.

## Results

Measurable PPG traces were obtained from the oesophagus in all patients (see Figure 4). The oesophageal PPG signals recorded from all patients were of good quality and large amplitudes. The optimal monitoring oesophageal depth ranged from 13 cm to 20 cm, measured from the upper lip (mean  $\pm$  SD: 15.6  $\pm$  1.8 cm).

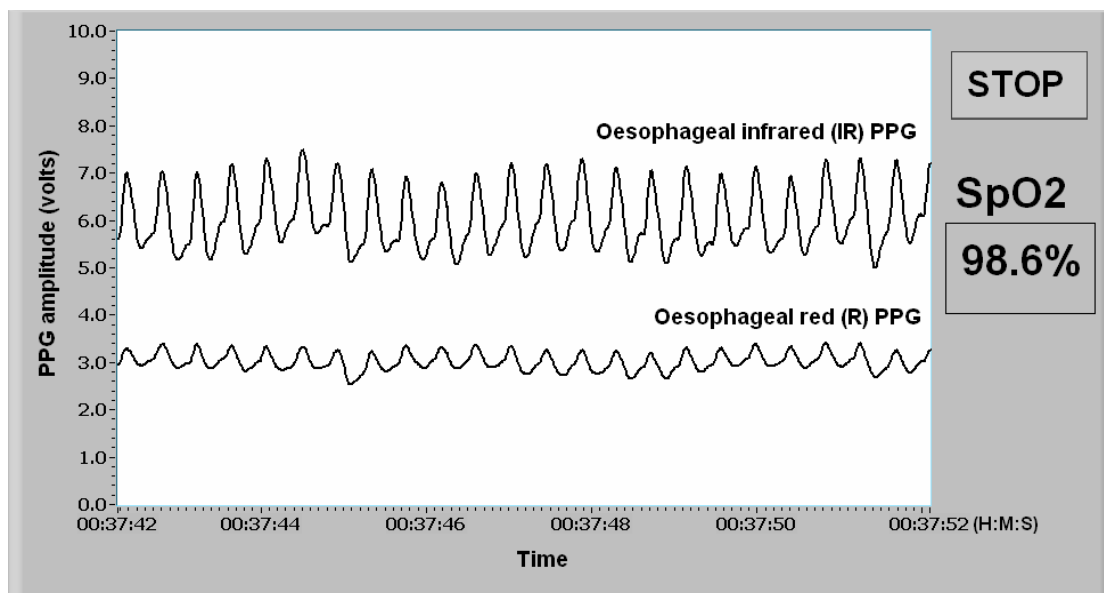

Figure 4: Real time oesophageal PPG traces from a burned patient

A total of 19 pairs of data points, obtained from the CO-oximeter and the oesophageal pulse oximeter, from all seven patients were used for the regression analysis, which gave the estimated slope and intercept of the regression line.

A plot of SpO<sub>2</sub> readings obtained from the reflectance oesophageal pulse oximeter (OES SpO<sub>2</sub>) against the SaO<sub>2</sub> values from the CO-oximeter is shown in Figure 5. The equation of the best fit linear regression line is: (OES SpO<sub>2</sub>) = 33.278 + 0.666 (CO-ox SaO<sub>2</sub>) (the solid line in Figure 5);  $r^2 = 0.49$ ; Standard Error of Estimate (SEE) = 0.64;  $p < 0.001$ . The dashed line represents the line of identity. The mean ( $\pm$  SD) of the differences between the oesophageal pulse oximeter SpO<sub>2</sub> values and the corresponding CO-oximeter readings (OES SpO<sub>2</sub> - CO-ox SaO<sub>2</sub>) is  $0.50 \pm 0.69\%$ .

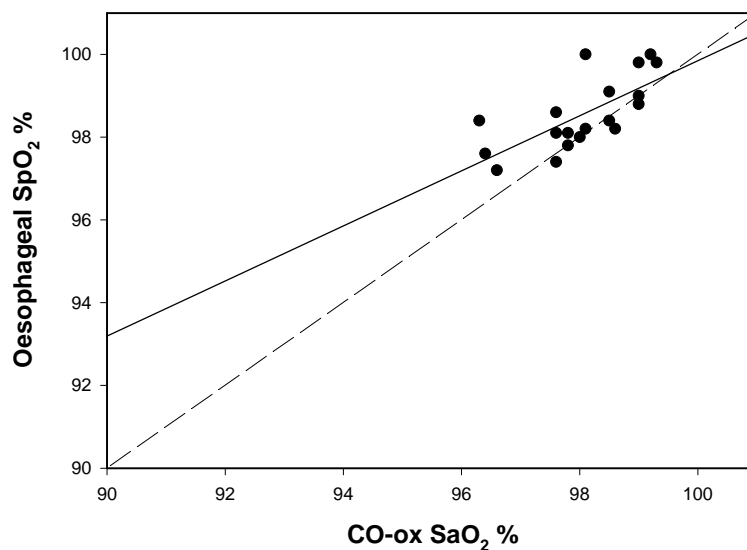

Figure 5: Plot of SpO<sub>2</sub> measurements obtained from the oesophageal pulse oximeter (OES SpO<sub>2</sub> against SaO<sub>2</sub> from the CO-oximetry (CO-ox SaO<sub>2</sub>) for 7 patients. The solid line represents the best fit linear regression line: (OES SpO<sub>2</sub>) = 33.278 + 0.66 (CO-ox SaO<sub>2</sub>);  $r^2 = 0.49$ ; SEE = 0.64;  $p < 0.001$ . The dashed line represents identity.



Figure 6 shows a plot of SpO<sub>2</sub> readings obtained from the commercial toe (transmittance) pulse oximeter (CT SpO<sub>2</sub>) against the SaO<sub>2</sub> values from the CO-oximeter. The equation of the best fit linear regression line was: (CT SpO<sub>2</sub>) = -53.854 + 1.550 (CO-ox SaO<sub>2</sub>); r<sup>2</sup> = 0.61; SEE = 1.15; p<0.001. The mean and standard deviation of the differences between the commercial toe pulse oximeter and the CO-oximeter readings (CT SpO<sub>2</sub> - CO-ox SaO<sub>2</sub>) is 0.11 ± 1.23 %.

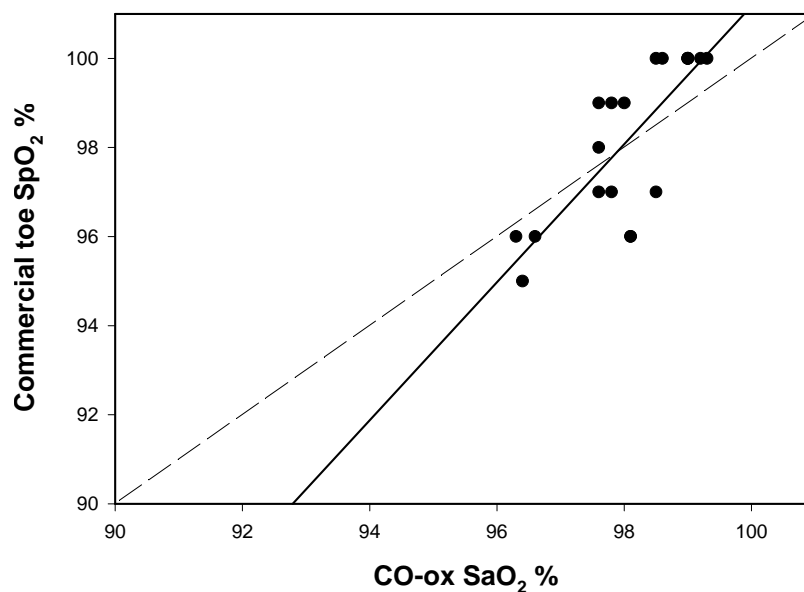

Figure 6: Plot of SpO<sub>2</sub> measurements obtained from the commercial toe pulse oximeter (CT SpO<sub>2</sub>) against SaO<sub>2</sub> from the CO-oximetry (CO-ox SaO<sub>2</sub>) for 7 patients. The solid line represents the best fit linear regression line: (CT SpO<sub>2</sub>) = -53.854 + 1.550 (CO-ox SaO<sub>2</sub>); r<sup>2</sup> = 0.61; SEE = 1.15; p<0.001. The dashed line represents identity.

Ninety two sets of blood oxygen saturation data points from the seven patients were used to compare the oesophageal and the commercial toe pulse oximeters. Since neither can be regarded as a “gold” standard, the *between-method differences* analysis as suggested by Bland and Altman<sup>9</sup> was used to compare these two pulse oximeters.

Figure 7 is a plot of the difference between the commercial toe (CT) and oesophageal (OES) SpO<sub>2</sub> values against their mean. As no obvious relation between the difference and the mean is revealed in Figure 7, a calculation of the bias, estimated by the mean difference (d) and the standard deviation of the differences (s) was performed to assess the degree of agreement between the two methods. The bias (d) (commercial pulse oximeter minus oesophageal pulse oximeter) was 0.4% and the standard deviation (s) was 2.1%.

The limits of agreement for the SpO<sub>2</sub> data (commercial toe and oesophageal) were, therefore:

$$d - 2s = 0.4 - (2 \times 2.1) = -3.6 \%$$

$$d + 2s = 0.4 + (2 \times 2.1) = 4.6 \%$$

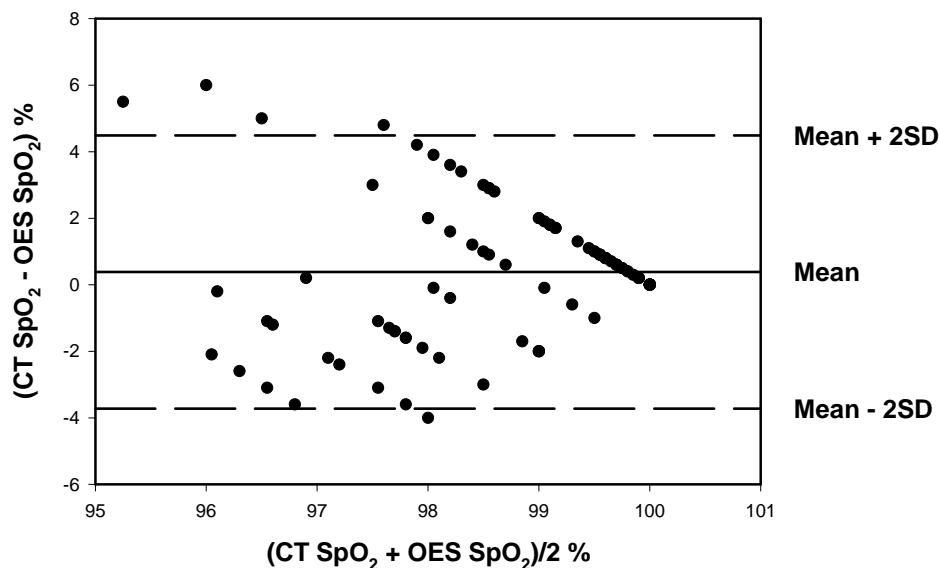

Figure 7 The difference between blood oxygen saturation values from the commercial toe pulse oximeter (CT SpO<sub>2</sub>) and SpO<sub>2</sub> readings obtained from the reflectance oesophageal pulse oximeter (OES SpO<sub>2</sub>) plotted against their mean for all seven patients.

## **Conclusion**

The aim of this study was to evaluate the reliability of oesophageal pulse oximetry in major burns patient. Good quality oesophageal PPG signals with large amplitudes were measured from various depths within the oesophagus. The optimal monitoring oesophageal depth ranged from 13 cm to 20 cm, measured from the upper lip.

It was found that the oesophageal pulse oximeter saturation results were in good agreement with those from the CO-oximeter (see Figure 3). In a direct comparison between the oesophageal and commercial toe pulse oximeters, using Bland and Altman analysis, the SpO<sub>2</sub> results from the two instruments were in very satisfactory agreement. Although there is some scatter the bias between them is only 0.4%. The limits of agreement from the analysis were 4.6 to -3.6 %.

In summary, the data suggest that oesophageal reflectance pulse oximetry may be a reliable and useful alternative method for monitoring continuous oxygen saturation in major burns patients.

## **Acknowledgement**

We gratefully acknowledge the financial support of the University of London Central Research Fund and the R&D Eastern Region.

## **References**

1. Dorlas, J. C., and Kuipers, A. H., Pulse oximetry--principle and first experiences during anesthesia, *Acta Anaesthesiol Belg.* **38(2)**, 133-138, 1987.

2. Mendelson, Y., and Ochs, B. D., Noninvasive pulse oximetry utilizing skin reflectance photoplethysmography, *IEEE Transactions on Biomedical Engineering* **35**, 798-805, 1988.
3. Kyriacou, P.A., Moye, A. R., Gregg, A., Choi, D. M. A., Langford, R. M., and Jones, D. P., A system for investigating oesophageal photoplethysmographic signals in anaesthetized patients, *Medical & Biological Engineering & Computing* **37(5)**, 639-643, 1999.
4. Kyriacou, P.A., Moye, A. R., Choi, D. M. A., Langford, R. M., and Jones, D. P., Investigation of the human oesophagus as a new monitoring site for blood oxygen saturation, *Physiological Measurement* **22(1)**, 223-232, 2001.
5. Kyriacou, P.A., Powell, S., Langford, R. M., and Jones, D. P., Investigation of oesophageal photoplethysmographic signals and blood oxygen saturation measurements in cardiothoracic surgery patients, *Physiological Measurement* **23(3)**, 533-545, 2002.
6. Kyriacou, P.A., Powell, S., Langford, R. M., and Jones, D. P., Esophageal Pulse Oximetry Utilizing Reflectance Photoplethysmography, *IEEE Transactions of Biomedical Engineering* **49(11)**, 1360-1368, 2002.
7. Kyriacou, P.A., Powell, S., Jones, D. P., and Langford, R. M., Evaluation of oesophageal pulse oximetry in cardiothoracic surgery patients, *Anaesthesia* **58(5)**, 422-427, 2003.
8. Kyriacou, P. A., Pulse Oximetry in the oesophagus, *Physiological Measurement* **27**, R1-R35, 2006.
9. Bland, J. M., and Altman, D. G., Statistical methods for assessing agreement between two methods of clinical measurement, *Lancet* **1**, 307-310, 1986.