



City Research Online

## City, University of London Institutional Repository

---

**Citation:** Parra, J., Cattell, R., Etemad, S. & Pullen, K. R. (2015). Performance Measurements of a Low Specific Speed TurboClaw (R) Compressor. IOP Conference Series: Materials Science and Engineering, 90(1), 12050. doi: 10.1088/1757-899X/90/1/012050

This is the published version of the paper.

This version of the publication may differ from the final published version.

---

**Permanent repository link:** <https://openaccess.city.ac.uk/id/eprint/16724/>

**Link to published version:** <https://doi.org/10.1088/1757-899X/90/1/012050>

**Copyright:** City Research Online aims to make research outputs of City, University of London available to a wider audience. Copyright and Moral Rights remain with the author(s) and/or copyright holders. URLs from City Research Online may be freely distributed and linked to.

**Reuse:** Copies of full items can be used for personal research or study, educational, or not-for-profit purposes without prior permission or charge. Provided that the authors, title and full bibliographic details are credited, a hyperlink and/or URL is given for the original metadata page and the content is not changed in any way.

---

City Research Online:

<http://openaccess.city.ac.uk/>

[publications@city.ac.uk](mailto:publications@city.ac.uk)

---

## Performance Measurements of a Low Specific Speed TurboClaw® Compressor

This content has been downloaded from IOPscience. Please scroll down to see the full text.

2015 IOP Conf. Ser.: Mater. Sci. Eng. 90 012050

(<http://iopscience.iop.org/1757-899X/90/1/012050>)

View [the table of contents for this issue](#), or go to the [journal homepage](#) for more

Download details:

IP Address: 138.40.68.78

This content was downloaded on 20/03/2017 at 16:37

Please note that [terms and conditions apply](#).

You may also be interested in:

[Experimental research on internal flow in impeller of a low specific speed centrifugal pump by PIV](#)

J F Zhang, Y F Wang and S Q Yuan

[Characteristic analysis on the pressure fluctuation in the impeller of a low specific speed mixed flow pump](#)

W W Zhang, Z Y Yu and B S Zhu

[Investigation on internal flow of draft tube at overload condition in low specific speed Francis turbine](#)

Yuta Tamura and Kiyohito Tani

[Velocity and pressure measurements in guide vane clearance gap of a low specific speed Francis turbine](#)

B S Thapa, O G Dahlhaug and B Thapa

[Numerical investigation of the flow phenomena around a low specific speed Francis turbine's guide vane cascade](#)

Sailesh Chitrakar, Biraj Singh Thapa, Ole Gunnar Dahlhaug et al.

[Application of a compressible flow solver and barotropic cavitation model for the evaluation of the suction head in a low specific speed centrifugal pump impeller channel](#)

P Limbach, T Müller and R Skoda

[Hydraulic performance of a low specific speed centrifugal pump with Spanwise-Slotted Blades](#)

D X Ye, H Li and Y Wang

[Impellers of low specific speed centrifugal pump based on the draughting technology](#)

C Hongxun, L Weiwei, J Wen et al.

# Performance Measurements of a Low Specific Speed TurboClaw® Compressor

**J. Parra, R. Cattell, S. Etemad**

Dynamic Boosting Systems Ltd, London

**K R Pullen**

City University London, School of Mathematics, Computer Science and Engineering

## Abstract

Low specific speed compressors have been historically based on positive displacement machines. Attempts to bring advantages of turbomachinery such as oil free, low parts counts, low cost of manufacture, and reliability to low flow rate applications have not been sparse, but the principle difficulty has always been that the conventional turbomachine design operates at ultra-high speed to deliver low volume flow rates. This is synonymous with low efficiency due to higher losses (windage, surface finish, and tip clearances). The innovative TurboClaw® design is a low specific speed turbomachinery with forward swept impeller geometry. It owes its high efficiency and operational stability to careful design of its nearly tangential forward swept blading and diffuser geometry.

The present contribution describes the design and development of a high speed test rig to accurately measure TurboClaw efficiency using shaft torque. The test rig employs a permanent magnet high speed motor designed and developed for this purpose. The motor shaft drives a single stage TurboClaw® compressor via a high speed torque sensor. The results are presented and compared to data obtained through an energy balance method well established for this geometry since its first innovative development at Imperial College in 2003. The accurate performance measurements have been used to design and test a two stage compressor to recover energy from waste steam. This is also briefly described.

## 1. Compressor systems

Compressors are fluid machinery devices that convert mechanical work into enthalpy rise of the fluid increasing its pressure and temperature such that the fluid is compressed. The compressed air can be stored or used for a variety of applications, usually by utilizing the stored energy as it converts to kinetic energy as it is depressurized. Compressors group into two main categories, positive or negative displacement machines but the latter group is more commonly known as dynamic machines, see Figure 1. Positive displacement machines work by intermittently trapping the fluid in a volume then reducing this volume before expelling to a high pressure. Common types include piston which pumps up a chamber and using controlled valves to draw in and discharge the working fluid, rotary screw with helical screws with reducing volume, and vane compressors with slotted rotor with varied blade



placement to guide working fluid into a chamber and compress the volume. It is noted that for positive displacement compressors sealing on moving surfaces are required, invariably requiring lower operational speeds, oil lubrication and/or costly tight tolerances. These characteristics increase wear, emissions and cost and reduce durability and reliability. For a given volume flow rate, positive displacement machines are larger and heavier than dynamic machines due to the combined effect of lower operational speeds and intermittency.

Dynamic compressors describe machines that transfer energy between a rotor and the working fluid and include centrifugal compressors, see Figure 1. These use a spinning impeller to accelerate the gas tangentially to high velocity and usually create pressure rise in the impeller by decelerating the fluid in the relative frame of the rotor. The exit fluid is then decelerated in stationary diffusers to convert kinetic energy to pressure. These machines are governed by Newton's second Law of Motion and Euler's turbomachinery equation. Turbomachines are inherently oil-free, but are driven by shafts supported by bearings, mostly oil lubricated but also grease packed, as well as oil-free air or magnetic bearings. It is noted that very high rotor speeds in the order of 100's m/s are necessary in order to obtain pressure rises of similar magnitude to atmospheric pressure. To illustrate this point, ignoring compressibility effects, the velocity needed for air at atmospheric pressure to have a dynamic pressure of 1 bar is 408 m/s based on Bernoulli principle. For a 50 mm diameter compressor impeller a rotational speed of 156,000 rpm would therefore be required. Two other important features of turbomachines are their continuous compression characteristics and high flow rates.

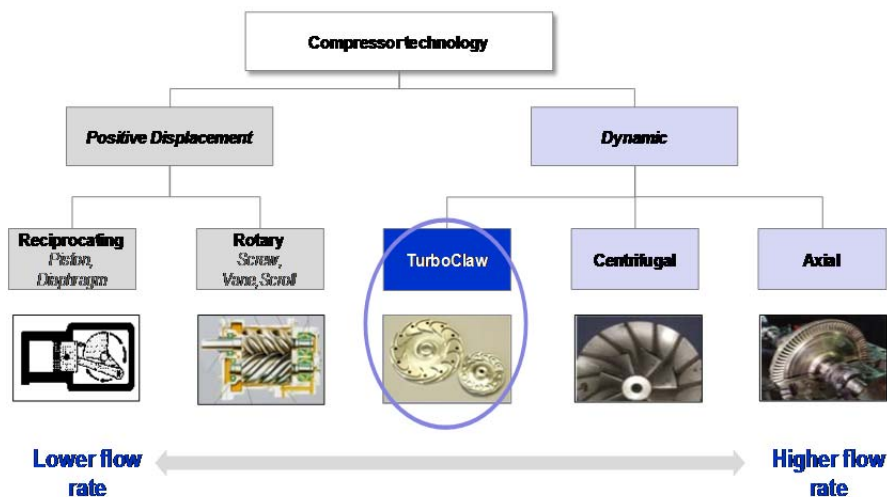

Figure 1: Compressor systems

The present contribution is based on research directed towards low flow rate turbomachine technologies and their development. The innovative TurboClaw is described and its performance characterised using a newly developed test rig. Geometric and performance scaling is briefly described as well as an important TurboClaw application, namely Mechanical Vapour Recompression (MVR).

## 2. Turbomachines with low flow rates

To determine the choice of machine to use for a given volume flow rate and pressure rise, a non-dimensional specific speed,  $N_s$ , is commonly used in preliminary design:

$$N_s = \omega \dot{Q}^{0.5} / \Delta h^{0.75} \quad \text{Equation 1}$$

where  $\omega$ ,  $\dot{Q}$ , and  $h$  are speed, volumetric flow rate and enthalpy respectively. Equation 1 is a particularly useful tool for choice of machine type and also for gauging performance of turbomachinery operating speed. The performance of some of the different types of machine is depicted in Figure 2 from [1] and shows turbocompressors are very efficient for large flow rates.

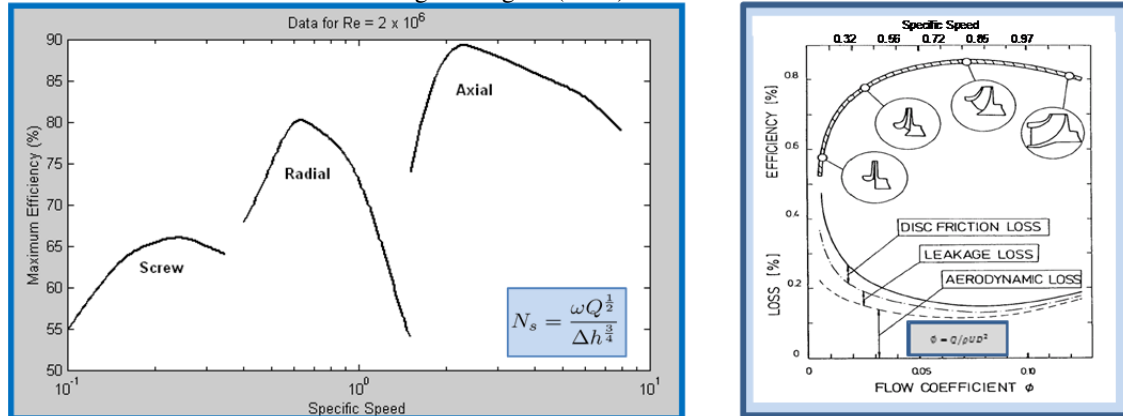

Figure 2: Left: Efficiency and specific speed [1]; Right: Low flow rate losses [2]

However these dynamic machines suffer from loss of efficiency when the specific speed is not optimal. It is immediately apparent from Equation 1 that for a given enthalpy rise, a low flow rate will necessitate either ultra-high shaft speeds or a suboptimal specific speed and efficiency will suffer. High shaft speeds may be impractically high that cost is unaffordable and life inadequate for the bearings and motors needed for support and drive. Shaft speed may also be restricted if the rotor is one of a number of stages or limited by the needs of other machinery. The reasons for poor efficiency under suboptimal specific speed are due to lower blade height to impeller diameter ratio with larger aerodynamic leakage and windage losses; see Figure 2 from [2].

To overcome the low flow rate turbomachines shortcomings of low efficiency and ultra-high speeds, designs including partial admission or partial emission in which the flow at impeller inlet or outlet is restricted, regenerative compressors in which the flow re-circulates in a single impeller, wedge-type with thick blading, and Barske with restricted volute have been devised. Table 1 presents comparative data of low specific speed technology demonstrating persistent shortcomings in both lower efficiency as well as high operational speeds.

Table 1 Comparative data for low specific speed machines

	Casey [3]	Wedge [4]	Barske [5]	Regenerative [6]
Impeller Diameter (m)	0.250	0.334	0.265	0.282
Tip speed (m/s)	200	347	483	74
Volume flow (m <sup>3</sup> /s)	0.0500	0.1878	0.0512	0.2600
N <sub>s</sub>	0.248	0.411	0.073	0.100
Polytropic Efficiency %	51.3	57.9	39.8	45

### 3. Innovation

The turbocompressor pressure ratio  $p_{out}/p_{in}$  is governed by the thermodynamics relationship, Equation 2, derived from [7];

$$\frac{p_{out}}{p_{in}} = \left( \frac{\eta_i \Delta h_o}{c_p T_{o,in}} + 1 \right)^{\frac{\gamma}{\gamma-1}} \quad \text{Equation 2}$$

Where  $T$  is temperature,  $\eta$  is efficiency,  $c_p$  is the specific heat at constant pressure, and  $\gamma$  is the ratio of specific heats. The Euler Turbomachinery equation, Equation 3;

$$\Delta h_o = U_{out} C_{\theta out} - U_{in} C_{\theta in} \quad \text{Equation 3}$$

where  $\Delta h_o$  is the work input to the gas and  $U$  and  $C_{\theta}$ , the blade speed and tangential velocities respectively. Subscripts are given to denote flow in and out of the impeller. Turbocompressors can be axial, radial or mixed flow but for the lowest volume flow-rate and for a particular pressure head, radial flow is the best, see Figure 1. For reasons of efficiency and widest operating map, it is normal practice to make the blade outlet angle slope away from the direction of rotation, creating what is termed backswept.

The use of forward sweep in order to increase Euler work, (Equation 3) and to reduce blade speed has been understood for many years. However, previous attempts found that efficiency deteriorated and the flow range of the compressor reduced, hence seldom used. The present innovation, trademarked TurboClaw, addresses this shortcoming by increasing forward sweep so substantially that the outlet blade angle becomes almost tangential. The design which ensues from this approach is shown in Figure 3 [8] along with the velocity triangle for the rotor outlet. It is also described in [9] and [10].

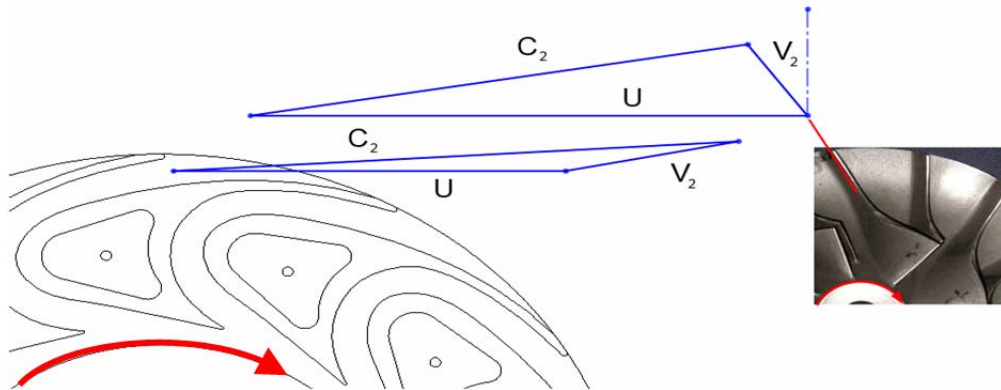

Figure 3: Impeller exit velocity triangle for TurboClaw (left) vs backswept turbocompressors (right)

Due to the effect of very thick blades which reduce the flow, it was found that the radial velocity can be extremely low relative to the tangential velocity without causing instability problems. The ratio  $C_{\theta 2}$  to  $C_{m2}$  can be up to 25:1 which is an order of magnitude above the limits for conventional designs. Since the radial velocity is so low, the increase in tangential velocity which arises due to increased flow rate is also very low. This means that the work input does not increase markedly with flow (see Equation 2) hence the slope of a constant speed line on the map is only marginally positive. In reality, the increase in losses with increased flow tends to mask this effect in any case leading to a compressor map not too dissimilar to a conventional backswept machine.

#### 4. Newly developed test rig

Performance measurements of TurboClaw based on energy balance was reported in [11]. Compressor efficiency was measured using the ratio of ideal power to real power. Ideal power was evaluated by

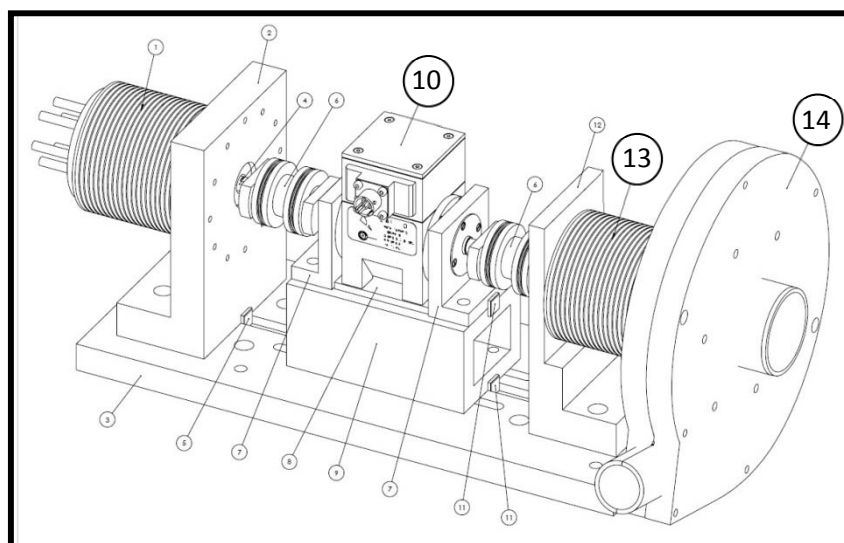

Figure 4: Newly developed test rig for compressor performance measurements

$\dot{m}c_pT_0 (PR^{(\gamma-1)/\gamma} - 1)$  where  $\dot{m}$  is the mass flow rate. The real power was determined based on measurement of heat to air and estimation of heat loss. The present contribution reports the development of a new test rig for high speed operation and shaft torque measurements,  $\tau$  in Nm, where power is calculated as the product of  $\tau$  and  $\omega$ . Referring to Figure 4, a high speed permanent magnet motor (item 1) is coupled via a torque sensor (item 10) to a second bearing-cartridge (item 13) supporting the compressor (item 14). The motor and bearing cartridge shafts are aligned accurately and connected to the torque sensor shaft using two diaphragm couplers (item 6).

The inline torque measuring system is based on measurements from a torque-proportional transformer coupling. This consists of two concentric shaft cylinders, together with corresponding concentric stationary coils, on each side of the shaft's deformation zone. A high frequency alternating current is used in the primary coil and a torque-proportional voltage is detected on the secondary coil when angular deformation is measured. Speed measurements are made using an optical sensor reading a toothed path machined directly on the shaft.

### 5. Performance Measurement

To assess compressor performance accurately, the test rig is operated without the compressor to establish a base case measuring losses such as bearings, rotor windage, and the windage of the diaphragm coupler (item 6). A regression analysis was performed for torque ( $\tau$  in Nm) vs shaft speed ( $\omega$  in rpm) data to establish equation 4.

$$\tau = 1.547 \times 10^{-18} \omega^3 + 1.067 \times 10^{-11} \omega^2 + 6.485 \times 10^{-8} \omega + 1.6 \times 10^{-3} \quad \text{Equation 4}$$

The correlation coefficient was 0.988. It is noted that windage and bearing losses were just 45% of the total loss with the diaphragm coupler (item 6) making up the difference of 56%.

The pressure ratio versus mass flow rate is depicted in Figure 5 for an 85 mm TurboClaw impeller developed as an electric supercharger [12] with  $N_s$  of 0.27 as calculated from Equation 1. With the compressor in position, tests were performed to accurately measure pressure ratio and mass flow rates as well as shaft torque that were reduced by Equation 4 to determine compressor torque. Compressor efficiency was then calculated based on the change of enthalpy and torque measurement, namely:

$$\eta_c = \frac{(h_{2s} - h_1) \dot{m}}{\omega \tau_c} \quad \text{Equation 5}$$

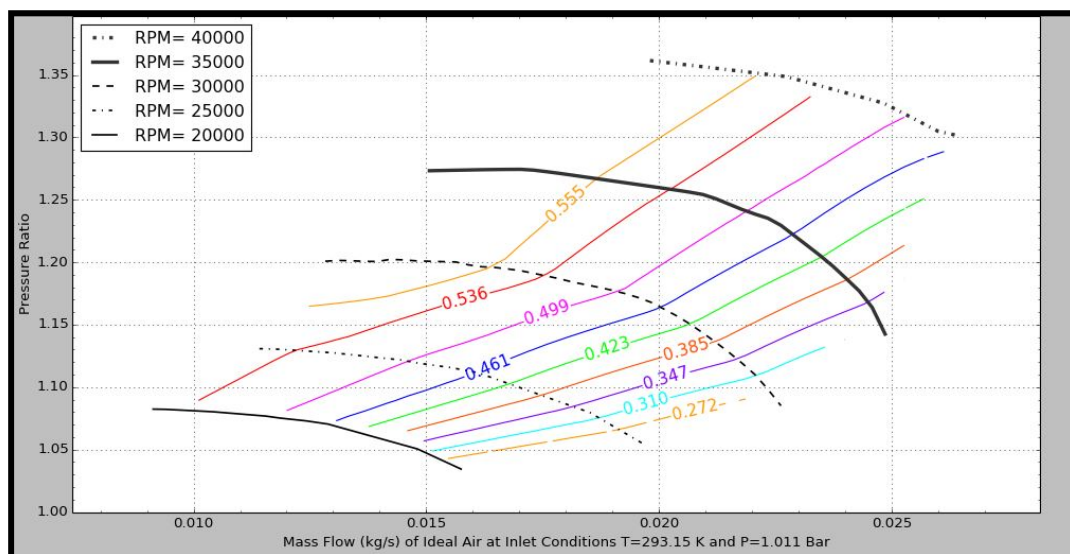

Figure 5: Performance measurements using test rig depicted in Figure 4



where  $\eta_c$  is compressor efficiency,  $\omega$  is shaft speed,  $h$  is enthalpy with subscripts 1 for inlet and 2s for delivery,  $\tau_c$  is compressor torque, and  $\dot{m}$  is mass flow rate. It should be noted that this is not a true isentropic efficiency since the real compression process is not fully adiabatic and heat transfer from the compressor will slightly reduce the actual work input as compared to a machine fully insulated. However, this efficiency is more meaningful as the ratio of isentropic work to actual work and is a correct measure of how much power is required to drive the compressor to produce the desired pressure rise.

The data in Figure 5 shows the familiar rising PR for lower mass flow rates to surge. Only five constant speeds lines are shown for brevity. The peak efficiency measured was at 59.4% that far exceeds the measurement of 52% of earlier designs reported in [11 & 12] for a larger impeller with  $N_s$  of 0.2 based on the less accurate and non-conservative energy balance method described earlier.

The efficiency data is also shown to be superior to the data presented in Table 1 for other known low specific speed machines and particularly so when compared to data from [3] at similar specific speeds.

## 6. Scaling effects

Efficiencies approaching 60% are highly competitive when measured against what can be achieved, if even possible, for oil free dry positive displacement compressors of similar low volume flow rates. It is known that turbomachines also greatly benefit from scaling effects and this aspect has been investigated. Turbomachinery can readily be scaled using Buckingham's similitude principles [13]. The scaling can be geometric (linear dimension), Kinematic (flow coefficient- same velocity triangles), Dynamic (same loading coefficient), and Energetic (same power coefficient). Scaling efficiency is however problematic due to difficulties in scaling surface finish, leakage, and matching fluid dynamics characteristics. The non-dimensional Reynolds number (ratio of inertial forces to viscous forces) is conventionally used to ensure dynamic similitude to scale efficiency based on the pioneering work of Pampreen [14], see Figure 6.

In practice, this is not always sufficient since very small changes to shape and surface roughness can result in very different flows. Nevertheless, Reynolds number is an important tool widely used to scale efficiency.

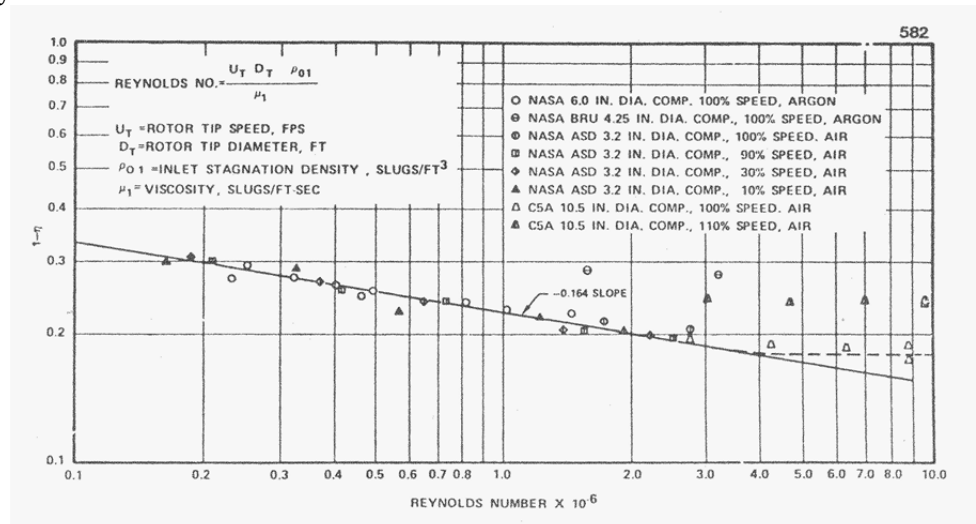

Figure 6: Reynold number scaling (data by Pampreen [14])

It is noted that the formulation for Reynolds number as in Equation 6 is based on a characteristic dimension stated as diameter here, but scaling blade height is also widely used.

$$Re_e = \frac{\varnothing V \rho}{\mu} \quad \text{Equation 6}$$

Where  $\varnothing$  is diameter,  $V$  is impeller tip speed ( $r\omega$ ),  $\rho$  is density, and  $\mu$  is kinematic viscosity.

The performance superiority of TurboClaw has been further investigated by re-plotting the data resented in Figure 2 from [1], see Figure 7. This shows conventionally designed radial turbomachinery with a Reynolds number of  $2 \times 10^6$  to drop to 50% efficiency at specific speed of 0.2. At lower Reynolds number the conventional designs suffers even further, see curve at Reynolds number 60,000 generated by scaling Moody friction factor and using the methodology prescribed by [14] and presented in Figure 6. TurboClaw data presented in Figure 5 are at specific speed of 0.27 and with measured efficiency of 59.4%. This is shown to have a superior performance at low specific speed for corresponding Reynolds numbers, see Figure 7. This is being further assessed but from Figure 7 the potential is substantial based on the difference between the green and blue curves for conventional machines.

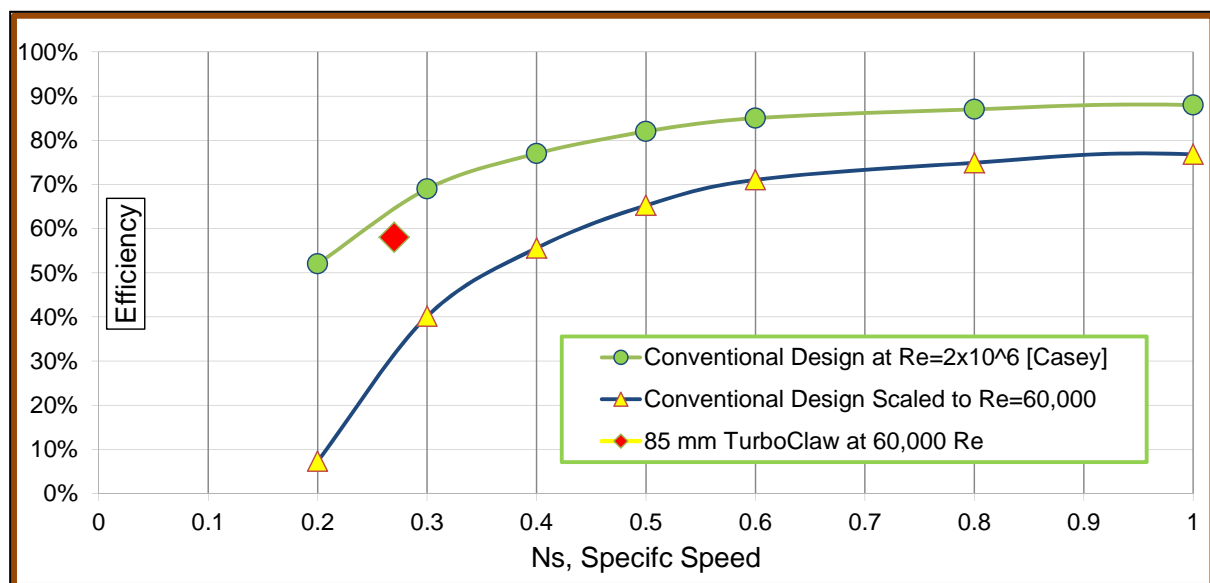

Figure 7: Comparison of measured TurboClaw data with corresponding data from the radial machine

For ideal gases, to predict the performance of a new compressor based on results from a different geometry, constant specific work is assumed even at different temperature and pressure inlet conditions using the corrected mass flow rate and speed. The assumption effectively means that the gas velocity is constant, hence compressor diameter and blade height become the main variables to keep specific work constant. This allows the designer to scale compressor geometries, but does not allow for change of working fluid or changes in tip speed when temperature changes.

For real gases, the changes to specific work can still stay constant, rather than the Mach number; provided the efficiency of the scaled geometry is corrected for changes in Reynolds number, see [14]. However, it is noted that for these cases the pressure ratio will be different, even for the same efficiency.

To assist application engineering, scaling software has been devised based on principles of similitude and Reynolds number scaling. The software uses a measured compressor map to predict candidate compressor performance and is interfaced with the data base from National Institute of Standards and Technology (NIST) to account for changes in the working fluid, [15]. To demonstrate, a two stage compressor for energy recovery from waste steam is described based on the Mechanical Vapour Recompression (MVR) principle. There are a multitude of applications for MVR including food and drinks processing. The main benefit of MVR is to recover waste energy in steam by compressing it to a higher pressure (hence temperature) and subsequently recover this heat in heat exchangers for re-use. System effectiveness could readily be gauged by working out the coefficient of performance (CoP) that is defined as heat recovery to drive electrical power ratio. The so called spark spread (price of gas versus electricity) can also be employed to work out the economic benefit in terms of pay-back time.

The two stage compressor was sized for a pressure ratio of around 1.5 with an electric motor of 30 kW. This enabled a range of pressure inlets and mass flow rates. Figure 8 depicts Coefficient of Performance (CoP) and pay-back period for the compressor against the mass flow rate that corresponds to inlet pressure. The two stage MVR compressor has been evaluated at pressure inlets of atmospheric, 3 bar, and 5 bar. Data show close correspondence to the predicted results depicted in Figure 8. Further tests are in progress.

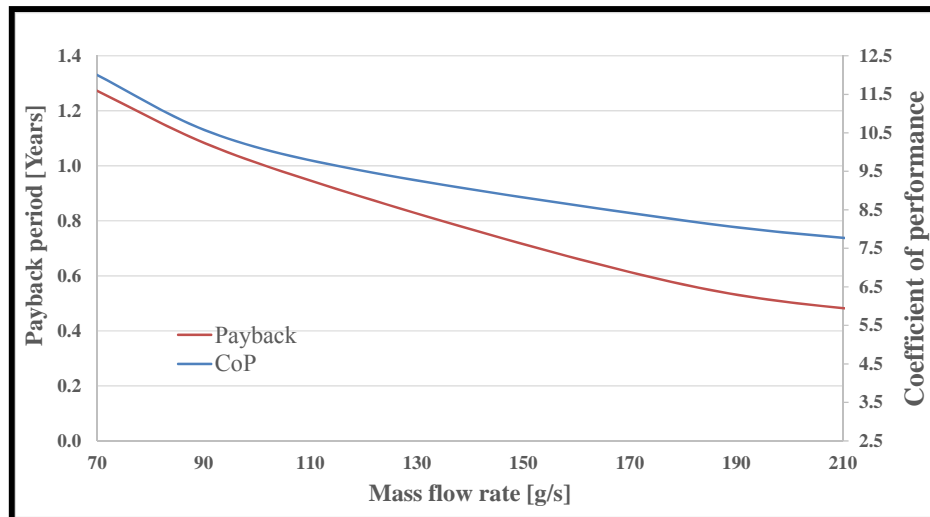

Figure 8: Two stage MVR with PR 1.5

## 7. Conclusions

Accurate efficiency measurements of forward swept low specific speed TurboClaw has been reported showing superior performance to conventional centrifugal designs at low specific speeds. This data has been used in proprietary software to design a compressor system for the mechanical vapour recompression application. The results show suitably high coefficient of performance to enable to quick pay-back period.

## References:

- [1] Casey, M.V. AGARD Lecture Series 195
- [2] Dalbert et al Journal of Mech Eng Science, v213, n1, 1999, pp71-83
- [3] Casey, M.V., Dalbert, P., Schurter, E. "Radial Compressor Stages for Low Flow Coefficients" IMechE paper C403/004 1990.
- [4] Rusak, V. "Development and Performance of the Wedge Type Low Specific Speed Compressor Wheel" ASME 27th International Gas Turbine Conference and Exhibition 1982
- [5] Barske, V.M. "Development of Some Unconventional Centrifugal Pumps" Proc. IMechE Vol 174 (1960) 437-461 129
- [6] Sixsmith, H., Altmann H. "A Regenerative Compressor" Trans ASME J. Engng for Industry, August 1977, 99, 637-647.
- [7] Sayers, A. T., "Hydraulic and compressible flow turbomachines" McGraw Hill 1990
- [8] Pullen, K. R. Etemad, S. and Cattell R., Proceedings of ASME Turbo Expo 2012, June 2012, Copenhagen, Denmark (GT2012-69074)
- [9] Patent GB2.366.333A, dated 06-03-2002.
- [10] PCT/GB04/003752, dated 9-03-2005.
- [11] Vine, A., PhD Thesis 'The Aerodynamic Design and Evaluation of a Low Specific Speed Turbo Compressor', Imperial College London 2005.
- [12] Electric supercharging for small downsized engines by Pullen, K., and Etemad, S., presented at Nlett Turbocharging Seminar Sept 2014 Tainjin, China
- [13] Buckingham, E. The principle of similitude. Nature 96, 396-397 (1915).
- [14] Pampreen, R. C., J. Eng. Gas Turbines Power 95(3), 251-256
- [15] <http://www.nist.gov> version 9.1