



City Research Online

City, University of London Institutional Repository

Citation: Shen, X., Camara, A. & Ye, A. J. (2015). Effects of seismic devices on transverse responses of piers in the Sutong Bridge. *Earthquake Engineering and Engineering Vibration*, 14(4), pp. 611-623. doi: 10.1007/s11803-015-0049-7

This is the accepted version of the paper.

This version of the publication may differ from the final published version.

Permanent repository link: <https://openaccess.city.ac.uk/id/eprint/17691/>

Link to published version: <https://doi.org/10.1007/s11803-015-0049-7>

Copyright: City Research Online aims to make research outputs of City, University of London available to a wider audience. Copyright and Moral Rights remain with the author(s) and/or copyright holders. URLs from City Research Online may be freely distributed and linked to.

Reuse: Copies of full items can be used for personal research or study, educational, or not-for-profit purposes without prior permission or charge. Provided that the authors, title and full bibliographic details are credited, a hyperlink and/or URL is given for the original metadata page and the content is not changed in any way.

City Research Online:

<http://openaccess.city.ac.uk/>

publications@city.ac.uk

Cite as:

Shen X, Camara A and Ye A (2015). Effects of seismic devices on transverse responses of piers in the Sutong Bridge. *Earthquake Engineering and Engineering Vibration*. 14(4):611-623. DOI: 10.1007/s11803-015-0049-7.

Effects of seismic devices on transverse responses of piers in the Sutong Bridge

Shen Xing^{1†}, Alfredo Camara^{2*} and Ye Aijun^{1§}

1. State Key Laboratory for Disaster Reduction in Civil Engineering, Tongji University, Shanghai 200092, China

2. Department of Civil and Engineering, City University, London, United Kingdom

Abstract: The Sutong Bridge in China opened to traffic in 2008, and is an arterial connection between the cities of Nantong and Suzhou. It is a cable-stayed bridge with a main span of 1,088 m. Due to a tight construction schedule and lack of suitable seismic devices at the time, fixed supports were installed between the piers and the girder in the transverse direction. As a result, significant transverse seismic forces could occur in the piers and foundations, especially during a return period of a 2500-year earthquake. Therefore, the piers, foundations and fixed bearings had to be designed extraordinarily strong. However, when larger earthquakes occur, the bearings, piers and foundations are still vulnerable. The recent rapid developments in seismic technology and the performance-based design approach offer a better opportunity to optimize the transverse seismic design for the Sutong Bridge piers. The optimized design can be applied to the Sutong Bridge (as a retrofit), as well as other bridges. Seismic design alternatives utilizing viscous fluid dampers (VFD), or friction pendulum sliding bearings (FPSB), or transverse yielding metallic dampers (TYMD) are thoroughly studied in this work, and the results are compared with those from the current condition with fixed transverse supports and a hypothetical condition in which only sliding bearings are provided on top of the piers (the girder can move “freely” in the transverse direction during the earthquake, except for frictional forces of the sliding bearings). Parametric analyses were performed to optimize the design of these proposed seismic devices. From the comparison of the peak bridge responses in these configurations, it was found that both VFD and TYMD are very effective in the reduction of transverse seismic forces in piers, while at the same time keeping the relative transverse displacements between piers and the box girder within acceptable limits. However, compared to VFD, TYMD do not interact with the longitudinal displacements of the girder, and have simpler details and lower initial and maintenance costs. Although the use of FPSB can also reduce seismic forces, it generally causes the transverse relative displacements to be higher than acceptable limits.

Keywords: Sutong Bridge; cable-stayed bridge; seismic devices; transverse response; bridge piers; viscous fluid dampers (VFD); friction pendulum sliding bearings (FPSB); transverse yielding metallic dampers (TYMD)

1 Introduction

The Sutong Bridge in China (Fig. 1), an arterial connection between the cities of Nantong and Suzhou, has a 1,088 m main span and two 500 m side spans. The steel box girder superstructure is supported by two towers, two transitional piers and four auxiliary piers. Each pier is composed of two 60 m-tall freestanding concrete columns, which are jointed together at the concrete pile caps. Each column has a hollow rectangular

section, which has out-to-out dimensions of 8.5 m in the longitudinal direction and 4.0 m in the transverse direction. The pier foundations consist of drilled caissons: 19 in each transition pier and each auxiliary pier next to a transition pier; and 36 in each auxiliary pier next to the tower. The drilled caissons are 2.5 m or 2.8 m in diameter and about 120 m in length.

The steel box girder of the Sutong Bridge is suspended vertically by stays and can move freely in the longitudinal direction, except that longitudinal viscous fluid dampers (VFD) will become effective during earthquakes and stoppers will be engaged when the girder moves more than 750 mm relative to the tower (Ye *et al.*, 2005). At the pier locations, sliding bearings have been installed to allow for free movements of the girder in the longitudinal direction. However, due to the existence of friction, these bearings do provide some longitudinal restraints, and their effective stiffness is determined by the vertical compressions, frictional coefficients and initial sliding displacement (2 mm). Due to a tight design

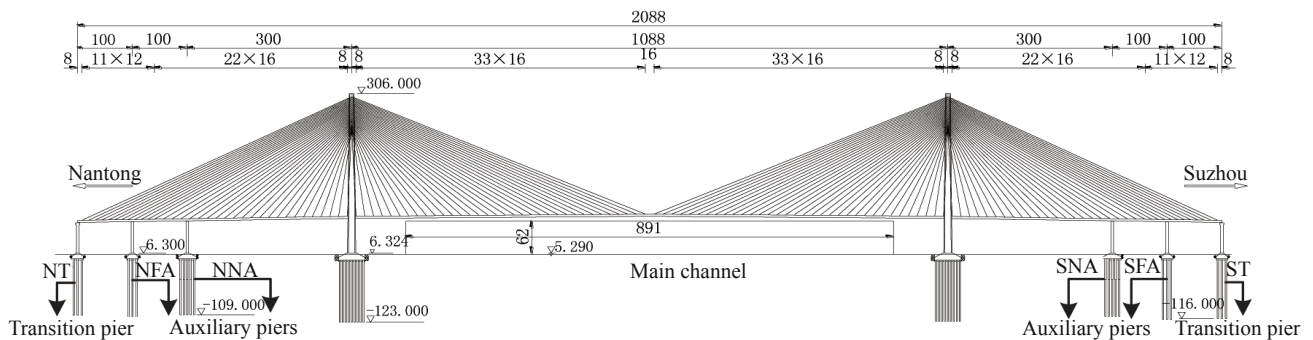

Fig. 1 Elevation of the Sutong Bridge (units: m)

and construction schedule and lack of suitable seismic devices, fixed bearings were employed in the transverse direction to restrain relative displacements between piers and the steel box girder. This kind of restraint is a common transverse means to resist earthquakes for cable-stayed bridges.

In order to meet navigational clearance requirements, the piers in the Sutong Bridge are very tall, about 60 m. It is desirable to keep tall piers in the elastic range during earthquakes to avoid excessive permanent deflections at the top of the piers. Furthermore, due to their strategic role in the national highway network, damage in structural elements during earthquakes are not allowed in long span cable-stayed bridges (Camara and Astiz, 2012; Hamburger and Hooper, 2011), meaning that these structural elements should remain in the elastic range even during earthquakes with a return period of 2500 years. But due to the existing transverse fixed constraints between the pier tops and the girder, large seismic forces could develop in the piers and foundations during design earthquakes (a return period of 2500 years). Consequently, piers and foundations were designed to have large dimensions. Furthermore, maximum transverse seismic forces in fixed bearings were 1.39 times their corresponding vertical loads (normally, transverse force is 10% of vertical load). As a result, special design and detailing were required for these bearings.

The above design approach is force-based, in which all structural elements should remain elastic under design earthquakes. However, during unexpected larger earthquakes, higher seismic forces may induce significant damage to these structural elements. The seismic damage in a cable-stayed bridge has already been reported: the tower and auxiliary piers of the Chi-Lu Bridge (Taiwan, China) suffered significant concrete spalling under the transverse seismic loads exerted by the Chi-Chi earthquake in 1999 (Chadwell, 2001; Chang *et al.*, 2004). To optimize the seismic design of the Sutong Bridge, it is necessary to seek better seismic devices that can be used at the top of the bridge piers to protect structural elements from being damaged.

Since Yao (Yao, 1972) presented the concept of structural control as an alternative approach to solve seismic safety problems in structural engineering, passive control seismic devices have been extensively explored. Seismic devices can be classified into two categories: velocity-dependent, e.g. viscous fluid dampers (VFD); and displacement-dependent, such as yielding metallic dampers (YMD). In long span bridges, VFD are commonly used as seismic devices in the longitudinal direction of the bridge, and have been studied extensively in recent decades. Villaverde (2009) compared the seismic performance of four types of passive dampers: (i) friction dampers; (ii) viscoelastic dampers; (iii) VFD; and (iv) YMD. Camara (2011) assessed the performance of YMD and VFD in the reduction of seismic responses of several cable-stayed bridges. McDaniel and his co-authors (McDaniel and Seible, 2005; Vader and McDaniel, 2007) addressed the influence of passive dampers and shear links on the seismic performance of the San Francisco-Oakland Bay Bridge in both the longitudinal and transverse directions. Seven long span bridges in China employed VFD in the longitudinal direction on the piers and/or at towers (Peng, 2011). The Rion-Antirion cable-stayed bridge (Greece) incorporates VFD on the pier tops in the transverse direction. The VFD performed well but complex structural details were needed to decouple the VFD from the longitudinal displacements of the bridges (Pecker, 2004; Tetssandier *et al.*, 2000).

YMD were first proposed by Kelly (Kelly *et al.*, 1971) to dissipate structural energy by means of nonlinear hysteretic cycles of metals. Even though YMD have been widely used in building construction and retrofit in recent decades, very few YMD have been used on bridges, especially in the case of long span cable-stayed bridges. Tyler (1978, 1985) designed bridge-used tapered cantilever steel dampers, manufactured with round bars or plates. The C-shaped yielding devices were used in the Bolu viaduct, which was a 2.3-km-long seismically isolated structure in Turkey (Panayiotis *et al.*, 2003). YMD with cantilever steel plates are potentially a good solution to reduce seismic responses in the transverse

direction of cable-stayed bridges, since it not only allows for longitudinal displacements of girders, but also shows stable hysteretic characteristics that could withstand low-cycle fatigue damage under strong ground motions (Tsai *et al.*, 1993). This type of damper is referred to as a triangular plate yielding metallic damper (TPYMD) hereafter. Camara (2011) extended the application of TPYMD to cable-stayed bridges and proved its efficiency in structures with moderate-to-medium spans between 200 and 400 m.

FPSB have good recentering capabilities and damping properties. Furthermore, they can effectively elongate the first vibration periods of structures and decrease maximum spectral accelerations. Tsopelas tested the effectiveness of friction pendulum sliding bearings (FPSB) on bridges by shake table tests. Many large bridges in China used FPSB to protect the main bridge structural elements from damage under severe ground motion (Zhang *et al.*, 2012). The results demonstrated that a substantial improvement in the seismic performance of the isolated bridge can be achieved that will sustain all levels of seismic excitation under elastic conditions (Tsopelas *et al.*, 1996).

Although passive devices have been explored and used extensively in the longitudinal direction in cable-stayed bridges the traverse direction has not. Since it is difficult to decouple the longitudinal seismic response of bridge piers when considering the transverse seismic problem, there are very few research work focused on the transverse seismic responses of bridges with passive dissipators and/or isolator devices, especially for long span cable-stayed bridges. This work proposes a new kind of seismic device called transverse yield metallic dampers (TYMD) combined with sliding bearings to solve the seismic problems of bridge piers in the transverse direction. Then, compared comparison with well-studied seismic devices (VFD and FPSD) is conducted to show that the TYMD was able to reliably dissipate energy in the transverse bridge piers. Because the Sutong Bridge is a typical cable-stayed bridge (basic information is presented above), the results can be directly extended to other long-span bridges.

2 Model methodology and seismic input of the Sutong Bridge

A detailed 3D finite element model was developed in SAP2000 (Fig. 2). The steel box girder, concrete piers and towers were modelled by elastic beam elements. The yielding strength of the steel girder was 370 MPa, the elastic modulus was 210 GPa, the shear modulus was 80.7 GPa and the Poisson ratio was 0.3. The compressive strength of the concrete in the piers and towers is 22.4 MPa, the elastic modulus was 33 GPa, the shear modulus was 14.1 GPa and the Poisson ratio was 0.17. Truss elements were used to model the stay cables, which have an equivalent elastic modulus for taking into account the sag effects based on Ernst's theory (Thai and Kim, 2008; 2012). Nonlinear geometric (P-Delta) effects were included in the analysis as well. Bearings were modelled by nonlinear spring elements. Six linear elastic springs were placed at the cap bottom to simulate the stiffness of the foundations. An incremental iterative method was employed to integrate the coupled nonlinear system of dynamics based on the Hilber-Hughes-Taylor algorithm (Chopra, 2001; Hilber *et al.*, 1977). The three fundamental modes are $T = 15.39$ s (longitudinal), $T = 9.98$ s (transverse), and $T = 5.63$ s (vertical).

Two seismic levels, Level I earthquake ($P1$, $T_r = 1,000$ years) and Level II earthquake ($P2$, $T_r = 2,500$ years), have been considered in the design of the Sutong Bridge. Considering their important role in a transportation network, structural elements should remain elastic under a Level II earthquake. Therefore, this study is based on seismic responses from Level II earthquakes. Site-specific target transverse and vertical response spectra (assuming 5% damping) for Level II earthquakes were developed by the Earthquake Engineering Research Institute of Jiangsu Province. The peak spectrum acceleration in the transverse direction is 3.91 m/s^2 in the period range from 0.25 s to 1.08 s. The peak spectrum acceleration in the vertical direction is 2.59 m/s^2 from 0.1s to 0.6 s. One (1) set of vertical and ten (10) sets of transverse synthetic accelerograms were developed from the site-specific spectra, as shown in Fig. 3(a). Two selected vertical and transverse synthetic

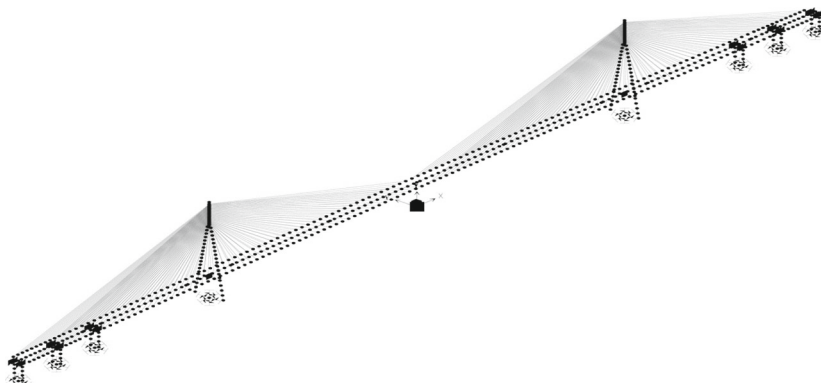

Fig. 2 Finite element model of the Sutong Bridge

accelerograms are shown in Figure 3(b) and 3(c). The PGA of the transverse acceleration time history record is 1.68 m/s^2 and the PGA of the vertical acceleration time history is 1.1 m/s^2 . The duration of the acceleration time history records is 66 s. Analyses were conducted in the transverse direction with both transverse and vertical ground motions, which were imposed at the foundations of the bridge. Seismic responses presented below were obtained through averaging the results from 10 sets of transverse ground motions, each of which was combined with the same set of vertical ground motions.

In the optimization of transverse seismic devices for the auxiliary and transition piers in the Sutong Bridge, three types of seismic devices were considered: (1) VFD plus sliding bearings; (2) FPSB; and (3) transverse yielding metallic dampers (TYMD) plus sliding bearings. By comparing bending moments at the bottom of the piers and pier-girder relative transverse displacements, each of those three seismic devices was optimized by selecting appropriate design parameters. Then the responses of the three optimized seismic device systems, “free” bearing system and those of the fixed bearing system (existing condition) were compared to determine a superior transverse seismic system for the Sutong Bridge.

3 VFD plus sliding bearings

VFD can be used in combination with sliding bearings (Fig. 4) to reduce the relative displacements between piers and the girder. In order to analyze the effects of VFD in structures, mathematical models of VFD have been developed, such as Kelvin, Maxwell and Wiechert models (Schwahn and Delinic, 1988). In this work, the most common Maxwell’s model, which defines each damper by a dashpot and a spring in parallel,

was employed.

The damper force can be described by the following equation:

$$f_d = C_\alpha \operatorname{sgn}(\dot{u}) \left| \dot{u} \right|^\alpha \quad (1)$$

In this formula, f_d is the force of the VFD; C_α is the viscous damping coefficient, which is defined by the diameter of the fluid cylinder, piston and viscous medium; \dot{u} is the relative velocity and $\operatorname{sgn}(\cdot)$ is the sign function; α is the velocity exponent, which typically ranges from 0.35 to 1 for seismic applications (Peng, 2011). If $\alpha = 1$, the above equation represents a linear force-velocity relationship in the VFD.

It is evident that the dissipative performance of the VFD is governed by two parameters: the viscous damping coefficient C_α and velocity exponent α . The value adopted for the viscous damping coefficient C_α in this work ranges from 0 to $5,000 \text{ kN}(\text{s/m})^\alpha$. When C_α is 0, it means that there are only sliding bearings installed between the girder and pier tops. For the Sutong Bridge or other long span cable-stayed bridges, the period of the first transverse mode is fairly low, and the peak velocities in the transverse direction are fairly high (usually larger than 1 m/s), making the energy dissipation of the VFD insensitive to the value of α (Peng, 2011). Therefore, a reasonable value of $\alpha = 0.5$ was considered in the numerical model.

Figure 5 shows the seismic responses of the bridge with the VFD, whose damping coefficient, C_α , ranges from 0 to $5,000 \text{ kN}(\text{s/m})^{0.5}$ in order to optimize the VFD effectiveness. The peak displacements of the north end of the girder (NG) and the south end of the girder (SG) are both presented. The pier designations in Fig. 5 are shown in Fig. 1.

The results reveal that by increasing the damping

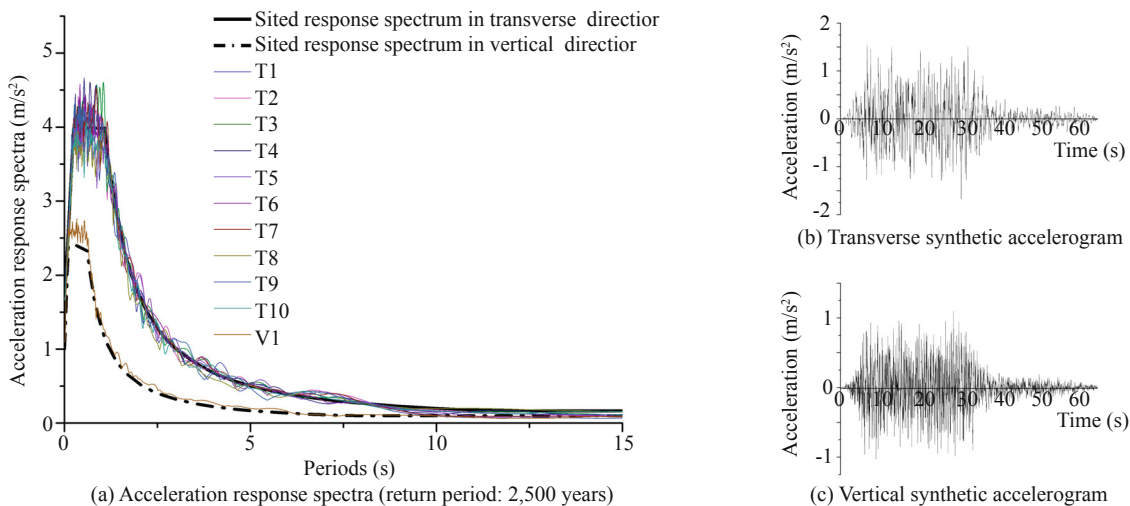

Fig. 3 Seismic spectrum and accelerograms for the Sutong Bridge

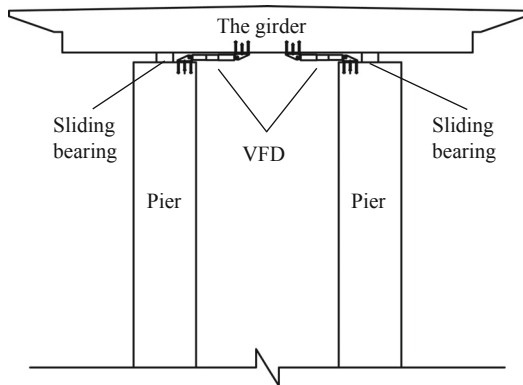

Fig. 4 VFD plus sliding bearings

coefficient C_α , the relative movements between the pier tops and the girder decreases, whilst the damper force increases. Meanwhile, bending moments at the pier bottom sections are first reduced as C_α increases, reaching the minimum values for all piers at almost the same value of C_α ; then, as C_α increases, the bending moments also become larger. This observation is in agreement with the results obtained by Siringoringo and Fujino (Siringoringo and Fujino, 2005) in the seismic analysis of the Yokohama Bay cable-stayed bridge (Japan). The above trend of pier bending moments is caused by the fact that damper forces are almost 90 degrees out-of-phase with the inertial forces of the piers. When the damping coefficient C_α of the VFD is low, the damper

forces are relatively small and bending moments in piers are dominated by the inertial forces of the piers, i.e. the piers vibrate more like free standing high columns; as the damping coefficient, C_α of the VFD increases, the bending moments in the piers become more and more governed by the damper forces, i.e. the piers become transverse supports for the girder during earthquakes and are more effective in restraining transverse girder movements.

The results demonstrate that in the transverse direction, VFD located between the girder and pier tops could be very effective in reducing earthquake responses. In order to limit the relative movements between the girder and piers to be within the 0.3 m design criteria for the Sutong Bridge, a damping velocity exponent, α , of 0.5 and a damping coefficient, C_α , of 3,000 ($\text{kN}\cdot(\text{s}/\text{m})^{0.5}$) were used, resulting in a peak damper displacement of 0.285 m and a maximum damper force of 3,360 kN.

Since the Sutong Bridge may also experience large movements in the longitudinal direction, it is difficult to make VFD effective in the transverse direction. The structure should be designed to decouple the VFD from the longitudinal displacements, as is the case in the Rion-Antirion cable-stayed bridge (Greece) mentioned above.

4 Seismic system employing FPSB

FPSB (Fig. 6) are bearings with self-recentering capability.

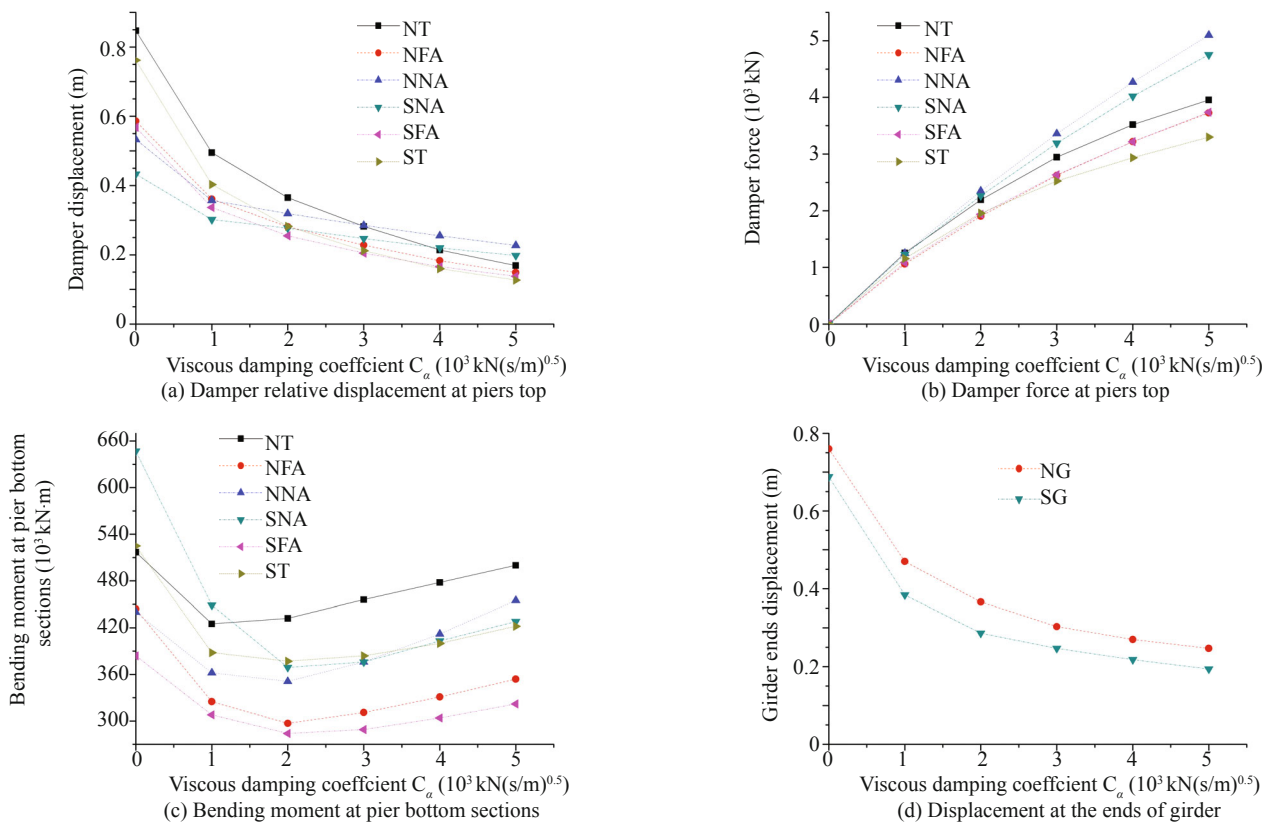

Fig. 5 Peak seismic responses with VFD

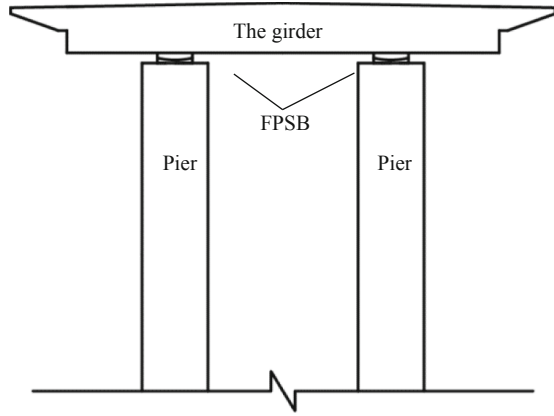

Fig. 6 FPSB on Piers

The mechanical properties of FPSB under cyclic load can be modeled as a bilinear hysteretic model, and the post-sliding stiffness of FPSB can be expressed as (Tsopelas *et al.*, 1996):

$$K_{py} = \frac{W}{R} \quad (2)$$

where K_{py} is the recentering stiffness, W is the vertical reaction force under dead load, and R is the radius of the curved sliding surface. The elastic stiffness of FPSB (K_{ES}) depends on the vertical reaction force (W), the coefficient of kinetic friction (μ) and the elastic displacement of FPSB (Δx), as defined below (Tsopelas *et al.*, 1996):

$$K_{ES} = \mu \frac{W}{\Delta x} \quad (3)$$

The basic design parameters of FPSB for the transition piers and auxiliary piers in the Sutong Bridge are presented in Table 1.

The post-sliding stiffness K_{py} is an important parameter to determine the mechanical properties of FPSB. Here, the relative stiffness ratio, η , which is the ratio of the recentering stiffness over the elastic stiffness, as shown in Eq. (4), is selected as an index to evaluate the seismic performance of FPSB for the Sutong Bridge in the transverse direction.

$$\eta = \frac{K_{py}}{K_{ES}} \quad (4)$$

Based on vertical reaction forces and geometrical design constraints of FPSB, the radii of FPSB in transition piers (NT, ST), auxiliary piers far from the towers (NFA, SFA) and auxiliary piers near the towers (NNA, SNA), were varied from 1.5–10 m, 1.8–10 m, 2.3–10 m, respectively, and the η ratio, respectively, were varied from 0.01–0.067 (NT, ST), 0.01–0.056 (NFA, SFA), and 0.01–0.043 (NNA, SNA).

Relative displacements of FPSB, as shown in Fig. 7(a), first increase with η , then as η goes beyond a certain value the displacements are reduced. In Fig. 7(b), the forces of FPSB increase with the increase of the η ratio. In Fig. 7(c), peak bending moments at the bottom sections of the piers only become slightly smaller as the η ratio increases. The peak transverse displacements at the end of the girder first increase, and then become smaller, as shown in Fig. 7(d).

It is observed that as the η ratio becomes larger, the transverse girder ends displacements and the relative displacements of FPSB are only slightly reduced, and in all cases they are larger than the displacement design limit (0.3 m) for the Sutong Bridge.

5 TYMD plus sliding bearings

Based on the aforementioned research work, YMD with triangular geometrical configuration plates have a superior dissipating capacity. In order to apply YMD in the transverse direction, the YMD should be able to accommodate both the longitudinal displacements and the rotations about the transverse direction.

Thus, a new design, named Transverse Yielding Metallic Dampers (TYMD) illustrated in Fig. 8, was proposed to be used in the piers of cable-stayed bridges in order to reduce the transverse seismic responses. TYMD are composed of triangular plates, sliding plates and semi-sphere force-conducting units. Two metallic semi-sphere conducting force units are located on the top of the triangular plate to slide on the surface of sliding plates. Thus, TYMD should not only be able to move longitudinally, but also reliably transfer transverse forces during earthquakes. Because of the restoring forces of the stays, cable-stayed bridges are inherently self-centering systems. Therefore, TYMD can be used in combination with sliding bearings to reduce the transverse relative displacements between the girder and top of the piers.

Table 1 Basic design parameters of FPSB in the Sutong Bridge

Bearing location	Vertical reaction force (kN)	Elastic disp. (m)	Coefficient of kinetic friction	Horizontal friction force (kN)	Elastic stiffness (kN/m)
Transition piers	2500	0.002	0.02	50	25000
Auxiliary piers far from towers	4500	0.002	0.02	90	45000
Auxiliary piers near towers	6900	0.002	0.02	138	69000

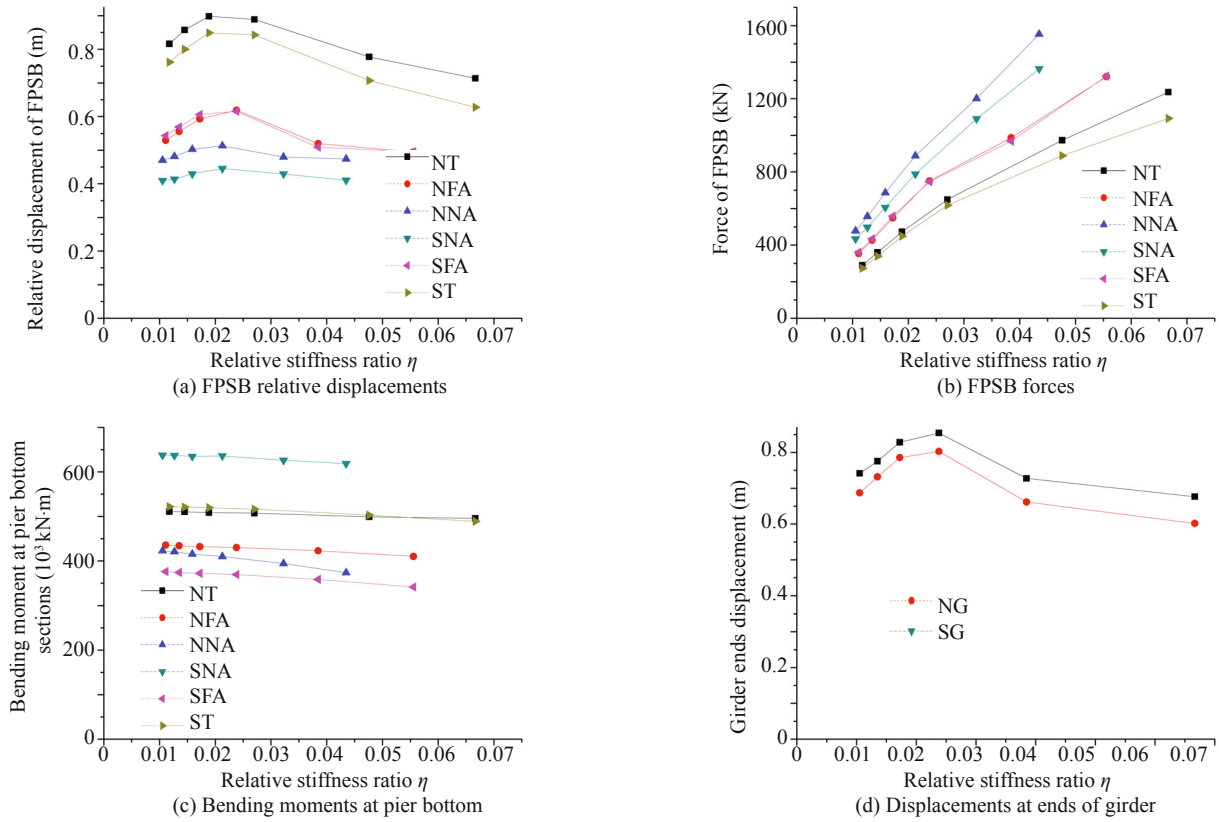

Fig. 7 Seismic peak responses with FPSB

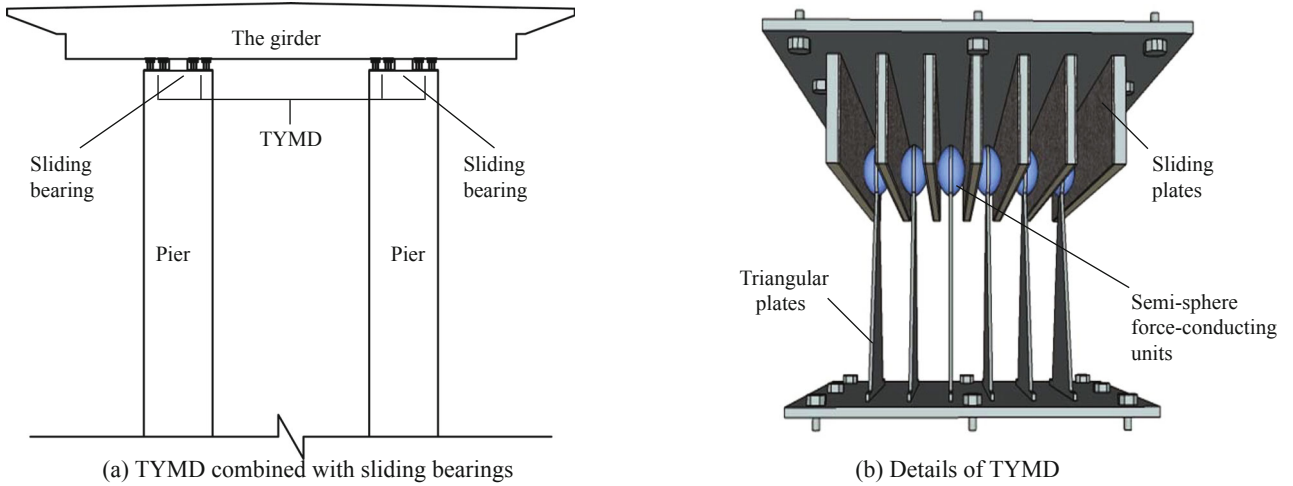

Fig. 8 TYMD plus sliding bearings between the girder and top of piers

The mechanical behavior of TYMD can also be expressed by a bilinear constitutive model. The yielding force of TYMD is determined through the formula suggested by Priestley *et al.* (1996), which is:

$$F_{pl,TYMD} = 0.85 \times 0.9 \times F_{pl, pier} \times \beta \quad (5)$$

$F_{pl,TYMD}$ is the lateral force causing yielding when applied on the apex of the TYMD. $F_{pl, pier}$ is the lateral force on the pier tops when initial damage at the pier bottom sections appears. The coefficient 0.85 is a safety factor

to ensure that the TYMD devices yield before the piers. Furthermore, a reduction of 10% is applied to take into account possible variations in the expected damper properties, e.g. imperfections during construction or deviation of the steel properties. β is the yielding level factor, which is introduced in this work to adjust the damage level of bridge piers under strong ground motions based on the importance of the structure.

Once the yielding force of TYMD is obtained, its mechanical parameters can be determined by the following formulas:

(i) Obtain the yielding moment at the bottom section of the triangular plate (TP):

$$M_{pl,TP} = \frac{1}{6} \times \sigma_y \times t^2 \times B \quad (6)$$

where σ_y is the yielding stress of the steel; t is thickness of the TP; and B is the width of the bottom section.

(ii) Obtain the lateral force that creates the yielding moment:

$$F_{pl,TP} = \frac{M_{pl,TP}}{H} \quad (7)$$

where H is the height of the TP.

(iii) Number of TPs:

$$N_p = \frac{F_{pl,TYMD}}{F_{pl,TP}} \quad (8)$$

(iv) Assume that the stress and strain of steel plate along the height reaches the yield stress and strain at the same time; the elastic stiffness of the TP can be expressed as:

$$K_{TP} = \frac{E \times B \times t^3}{6 \times H^3} \quad (9)$$

where E is the young's modulus of the steel.

(v) Obtain transverse yielding displacement of TYMD when yielding starts:

$$x_{pl,TYMD} = x_{pl,TP} = \frac{F_{pl,TP}}{K_{TP}} \quad (10)$$

where $x_{pl,TYMD}$ and $x_{pl,TP}$ are the yielding lateral displacement of TYMD and of a TP, respectively.

The relevant design parameters of the TYMD are shown in Table 2.

Herein, the material hardening is neglected, resulting in an ideal bilinear constitutive material model for the TYMD. With this assumption, the displacement results are considered conservative, even though this is not the case for the forces. However, displacements control the design in this case.

The value of the β factor, which ranges from 10% to 100%, is introduced to find the optimal balance between the bending moments at the pier bottom sections and the relative displacements between the girder and the piers.

From the results presented in Figs. 9(a) to 9(d), the following observations can be made:

(1) The damper relative displacements decrease with

the increase of the β factor. This result was expected from the combination of equation (5) and (10), because the yielding force of TYMD increases with the β factor.

(2) The damper forces increase with the increase of the β factor. The peak damper reactions in different piers are almost identical because the yielding forces of TYMD are the same, as shown in Table 2.

(3) The bending moments at the pier bottom sections, as shown in Fig. 9(c), reach the lowest values when the β factor is between 20% and 40%.

(4) The girder end displacements first decrease as the β factor becomes larger; but when the β factor exceeds 50%, these displacements almost remain constant, and below the maximum allowable value (0.3 m), as observed in Fig. 9(d).

These results prove TYMD can be a suitable seismic device for the Sutong Bridge, because it provides a high energy dissipation capacity during strong earthquakes and can reduce both transverse displacements and bending moments at the pier bottom sections. A yielding level factor $\beta = 50\%$ is selected because the relative movements between the girder and piers (damper displacements) were kept within acceptable levels, and the bending moments in the piers are also acceptable. Further increase of the β factor will result in much higher bending moments in the piers and more steel plates in TYMD. In summary, when the β factor is 50%, the maximum damper displacement is 0.324 m (slightly larger than the maximum allowed, but still acceptable), the maximum damper force is 5098 kN and the number of plates is 47 on each single pier top. This demonstrates that TYMD presents an ideal dissipating energy capacity except that the number of plates seems to be large. However, the number of plates can be reduced by optimizing the parameters of the triangular plates or by special structure design.

6 Discussion of the results

6.1 Comparison of different seismic devices

The optimal parameters of three types of seismic devices have been obtained in the preceding sections by means of parametric analyses. The transverse seismic responses of the bridge with these optimized seismic devices, with a "free" system with only sliding bearings and those from the existing system with fixed bearing

Table 2 Design parameters of TYMD

t (m)	B (m)	H (m)	σ_y (MPa)	E (GPa)
0.03	0.6	0.5	235	210
$F_{pl,TP}$ (kN)	$M_{pl,TP}$ (kN·m)	$F_{pl,TP}$ (kN)	K_{TP} (kN/m)	$X_{pl,TYMD}$ (m)
7780	31.725	63.45	4536	0.014

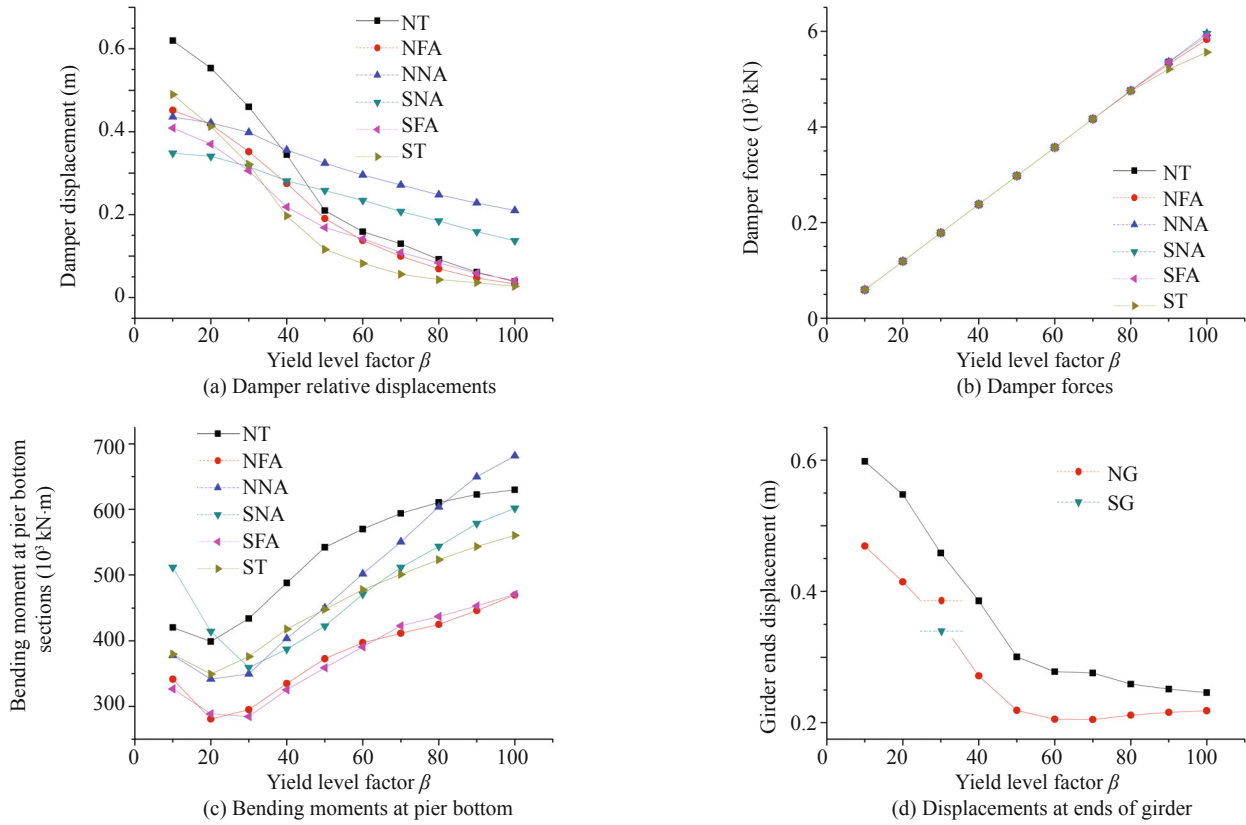

Fig. 9 Seismic peak responses with TYMD

are compared in order to obtain a more complete picture of the transverse seismic responses of the piers in the Sutong Bridge.

The following conclusions can be obtained from results in Table 3:

(1) By utilizing the VFD, the transverse girder ends displacements can be reduced to 40% of the value observed in the “free” system; and transverse bending moments at the pier bottom sections may be reduced to 54% of those in the existing Sutong Bridge. Furthermore, the relative peak displacement between the girder and piers is below 0.3 m.

(2) FPSB, compared with the “free” system, provides a slight reduction of transverse girder end displacements and transverse bending moments at the

pier bottom sections, but the transverse movements of FPSB is inadmissibly large.

(3) Compared to the “free” system, TYMD reduces transverse girder end displacements to 39%, and transverse bending moments in the pier bottom sections may be reduced to 65% of those in the existing Sutong Bridge;

(4) From the results of these five seismic systems, VFD and TYMD present good capacities in reducing the seismic response of the bridge piers and foundations.

As illustrated in Table 3, the largest seismic responses of the studied devices are recorded at the north auxiliary pier (NNA), close to the north tower. The force-displacement responses of the three seismic devices at this pier are presented in Fig. 10, which came from one

Table 3 Peak responses of seismic devices under synthetic record of Sutong Bridge

	VFD	FPSB	TYMD	Free	Fix
Optimal parameters	$C_a = 3000, \alpha = 0.5$	$\eta = 0.048$	$B = 50\%$	—	—
Displacements at end of girder (m)	0.303 (NG)	0.728 (NG)	0.3 (NG)	0.762 (NG)	0.251 (NG)
Bending moments at pier bottom section (kN·m)	456000 (NT)	625996 (SNA)	542260 (NT)	646722 (SNA)	839012 (NT)
Seismic device relative displacement (m)	0.285 (NNA)	0.778 (NT)	0.324 (NNA)	0.843 (NT)	0 (all)
Seismic device force (kN)	3360 (NNA)	1091 (SNA)	2976 (all)	138 (NNA)	12204 (NNA)

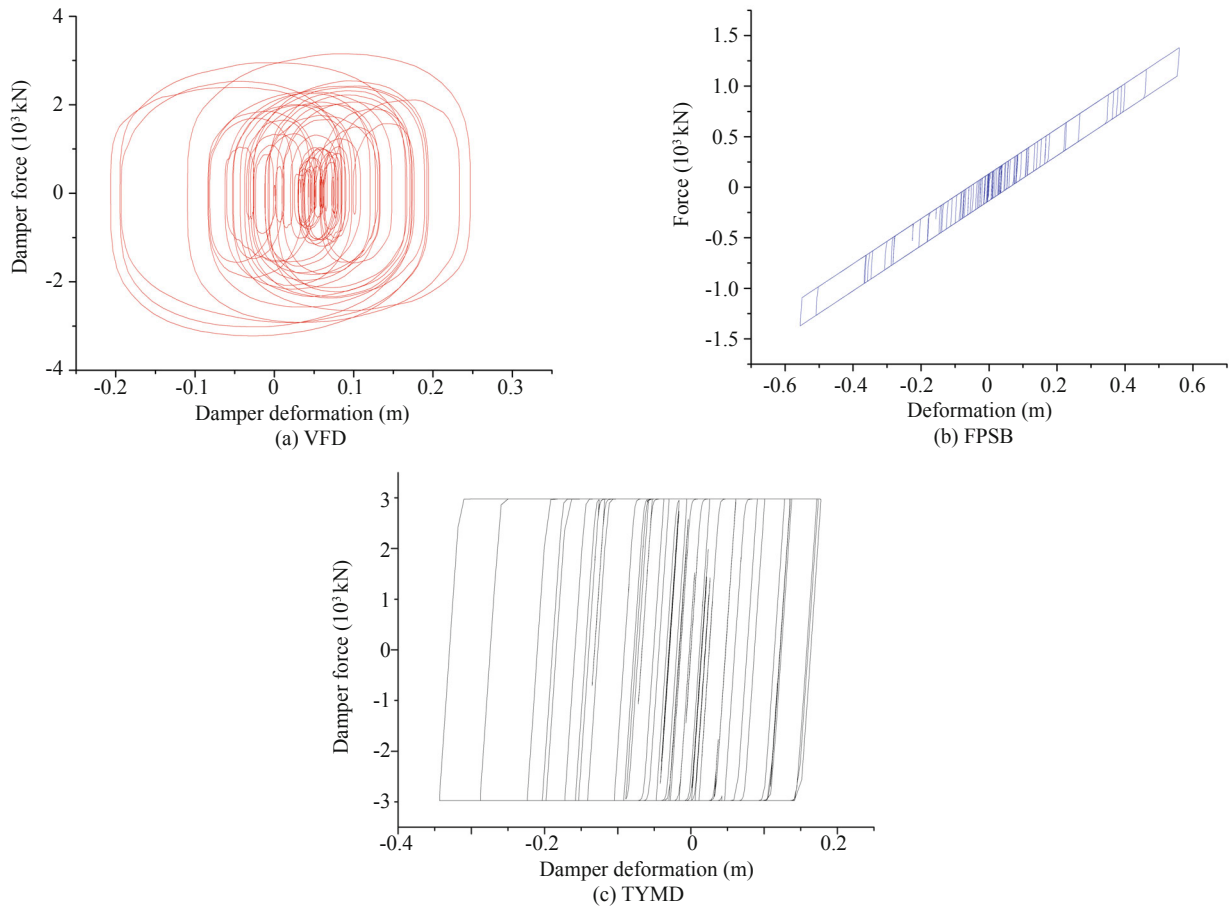

Fig. 10 Load-displacement curve of the optimized seismic devices

specific accelerogram (seismic input by combination transverse direction with vertical direction). The average dissipative energy of each seismic device is presented Fig. 11, which was obtained by averaging the results from all ten sets of ground motion records.

Figures 10 and 11 show that the shapes of the force-displacement responses of VFD are fully elliptical, meaning VFD is effective in dissipating energy, while those of FPSB is very narrow, meaning it is not effective in dissipating energy. The hysteretic dissipation of TYMD is similar to that of the VFD. In addition, TYMD could easily be designed to yield under different earthquake intensities. The average energy dissipation of VFD is the largest one and the energy dissipation of TYMD is only slightly smaller than VFD. The FPSB efficiency, in terms of energy dissipation, is poor, proving once again that this is not the ideal option to reduce the transverse seismic responses of the piers in the Sutong Bridge.

6.2 Check the effectiveness of seismic devices by observed seismic records

In order to check the effective dissipative energy of the seismic devices under observed accelerograms, Loma Prieta record and Chi-Chi record were selected

since they have the same site classification as the Sutong Bridge in terms of shear wave velocities (V_s is less than 140 m/s). The elastic acceleration response spectra of one synthetic record of the Sutong Bridge, Loma Prieta record and Chi-Chi record are compared and shown in Fig. 12(a). The transverse and vertical acceleration time history records of Loma Prieta and Chi-Chi are shown in Figs. 12(b) and 12(c), respectively.

The seismic performance of VFD, FPSB, TYMD (seismic device with its optimal parameter which is

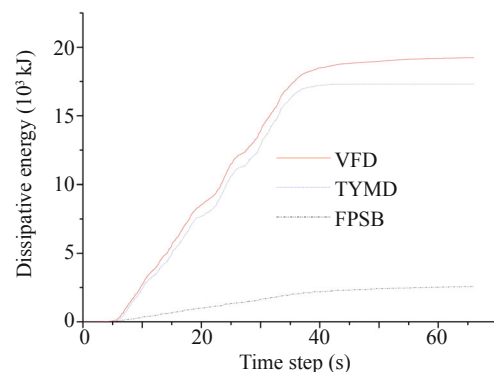
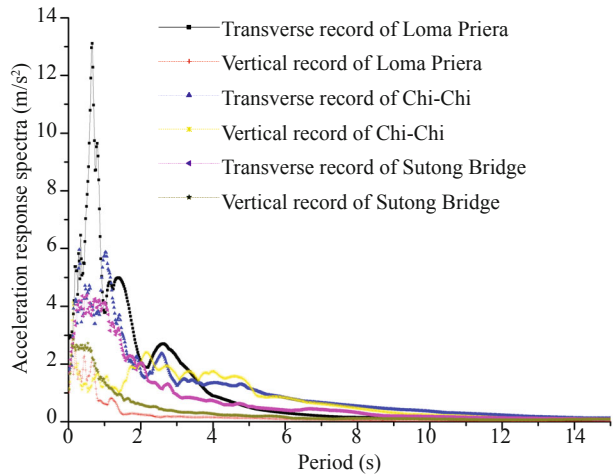
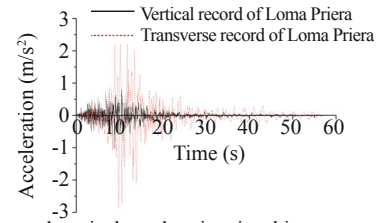

Fig. 11 Evolution of the energy dissipated by the seismic devices during the earthquake



(a) Acceleration response spectra of Loma Prieta record, Chi-Chi record and synthetic Sutong Bridge record



(b) Transverse and vertical acceleration time history record of Loma Prieta

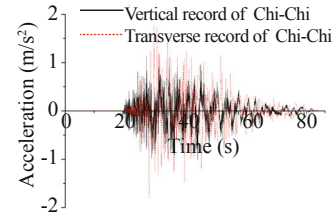

(c) Transverse and vertical acceleration time history record of Chi-Chi

Fig. 12 Seismic records from Loma Prieta and Chi-Chi earthquakes

analyzed by the Sutong site-specific seismic input), free system and fixed system are compared and checked by Loma Prieta and Chi-Chi records, and shown in Table 4. The strong motion station of the Chi-Chi earthquake is “TCU116” and the strong motion station of the Loma Prieta earthquake is “0005, FOSTER CITY -REDWOOD SHORES”.

For the Chi-Chi record, VFD and TYMD performed ideally with the optimized parameters. However, for the Loma Prieta record, the “free” case resulted in a larger bending moment at the pier bottom section than the fixed system. This is because the elastic acceleration spectrum of the Loma Prieta record abruptly increases in the period range between 1 s and 4s, in which periods of the main transverse modes of the piers in the “free” case locate. The parameters of VFD and TYMD should be optimized using the Loma Prieta record in order to satisfy the criteria of seismic responses, particularly the relative displacements of seismic devices. However, the dissipative energy capacity of five types of different

seismic systems obtained the same conclusion for the Loma Prieta and Chi-Chi records, as well as the Sutong record which was explicitly analyzed before.

7 Conclusions

Three-dimensional nonlinear time history analyses were conducted to study the influence of seismic systems on the transverse seismic responses of the Sutong Bridge under large ground shaking. Three seismic devices were considered in this study: VFD, FPSB and TYMD.

The results revealed that by using VFD between the girder and pier tops in the transverse direction of the Sutong Bridge, it effectively reduces the seismic response of the bridge. VFD possess the best energy dissipation capacity among the three seismic devices.

The seismic performance of FPSB depends on the vertical reaction force. In cable-stayed bridges, the bearing force is small because the cables transfer most

Table 4 Peak responses of seismic devices under real seismic records

		VFD	FPSB	TYMD	Free	Fix
Optimal parameters	Loma Prieta	$C_a = 3000, \alpha = 0.5$	$\eta = 0.048$	$\beta = 50\%$	—	—
	Chi-Chi					
Displacement at the end of girder (m)	Loma Prieta	0.387	0.671	0.312	0.663	0.268
	Chi-Chi	0.373	1.68	0.2	1.067	0.205
Bending moment at pier bottom section (kN-m)	Loma Prieta	827022	1497299	749412	1700048	1300696
	Chi-Chi	488188	549446	478738	594115	881720
Seismic device relative displacement (m)	Loma Prieta	0.512	0.847	0.534	0.707	0
	Chi-Chi	0.345	1.551	0.235	1.136	0
Seismic device force (kN)	Loma Prieta	4858	2173	2976	138	19879
	Chi-Chi	3204	3080	2976	138	11836

of the dead load to the tower. Consequently, the energy dissipating efficiency of this device is poor.

TYMD may offer an outstanding seismic performance in a cost efficient way. The yielding level β factor can be adjusted to optimize the seismic responses of piers in the transverse direction. When $\beta = 50\%$, the energy dissipated through the device is rather satisfactory, being similar to that obtained with VFD. Thus, key elements of the bridge substructure can remain in the elastic range during severe ground shaking.

Considering that the Sutong Bridge allows large deformations in the longitudinal direction, it is thus difficult to make VFD effective in the transverse direction, unless a special structure is designed. The ability of TYMD to adapt to the longitudinal deformation, its cost efficiency, the ease of fabrication and its low maintenance make it a superior transverse passive seismic device for piers in the Sutong Bridge.

Acknowledgement

This work was supported by the Ministry of Science and Technology of China, Grant No. SLDRCE 10-B-09 and grants from the 973 National Basic Research Program of China (No. 2013CB036302)

References

- Camara A (2011), "Seismic Behaviour of Cable-stayed Bridges: Design, Analysis and Seismic Devices," *PhD Thesis*, Technical University of Madrid (UPM), Madrid.
- Camara A and Astiz MA (2012), "Pushover Analysis for the Seismic Response Prediction of Cable-stayed Bridges under Multi-directional Excitation," *Engineering Structures*, **41**: 444–455.
- Chadwell C (2001), "Near-source Earthquake on the Ji-Lu Cable-stayed Bridge in the 21 September 1999 Chi-Chi Taiwan Earthquake," *PhD Thesis*, University of California, Berkeley.
- Chang KC, Mo YL, Chen CC, Lai LC and Chou CC (2004), "Lessons Learned from the Damaged Chi-Lu Cable-Stayed Bridge," *Journal of Bridge Engineering*, ASCE, **9**(4): 343–352.
- Chopra AK (2001), *Dynamics of Structures-theory and Applications to Earthquake Engineering*, Prentice Hall.
- Hamburger R and Hooper J (2011), "Performance-based Seismic Design," *Modern Steel Construction*, **51**(4): 36–39.
- Hilber HM, Hughes TJR and Talor RL (1977), "Improved Numerical Dissipation for Time Integration Algorithms in Structural Dynamics," *Earthquake Engineering and Structural Dynamics*, **5**: 282–292.
- Kelly JM, Skinner RI and Heine AJ (1971), "Mechanisms of Energy Absorption in Special Devices for Use in Earthquake Resistant Structures," *Bulletin of New Zealand National Society for Earthquake Engineering*, **5**(3): 63–88.
- McDaniel CC and Seible F (2005), "Influence of Inelastic Tower Links on Cable-supported Bridge Response," *Journal of Bridge Engineering*, **10**(3): 272–280.
- Panayiotis C, Roussisael CC, Mustafa E, Eser D and Murat D (2003), "Assessment of Performance of Seismic Isolation System of Bolu Viaduct," *Journal of Bridge Engineering (ASCE)*, **8**(4): 182–190.
- Pecker A (2004), "Design and Construction of the Rion Antirion Bridge," *Proceedings of the Geotechnical Engineering for Transportation Projects*, GSP, 126, Washington, DC, 216–240.
- Peng W (2011), "Applications of Linear and Non-linear Fluid Viscous Dampers to Seismic Response Control of Bridges," *PhD Thesis*, Tongji University, Shanghai. (in Chinese)
- Priestley MJN, Seible F and Calvi GM (1996), *Seismic Design and Retrofit of Bridges*, John Wiley & Sons, INC., New York.
- Schwahn KJ and Delinic K (1988), "Verification of the Reduction of Structural Vibrations by Means of Viscous Dampers," *Proceedings of the Pressure Vessel and Piping Conf*, Pittsburgh, PA, 87–95.
- Siringoringo DM and Fujino Y (2005), "Observed Dynamic Performance of the Yokohama-Bay Bridge from System Identification Using Seismic Records," *Journal of Structural Control and Health Monitoring*, **13**(1): 226–244.
- Tetssandier JP, Combault J and Morand P (2000), "The Rion Antirion Bridge Design and Construction," *12th World Conference on Earthquake Engineering*, Auckland, N.Z.: 1115–1127.
- Thai HT and Kim SE (2008), "Second-order Inelastic Dynamic Analysis of Three-dimensional Cable-stayed Bridges," *International Journal of Steel Structures*, **8**(3): 205–214.
- Thai HT and Kim SE (2012), "Second-order Inelastic Analysis of Cable-stayed Bridges," *Finite Elements in Analysis and Design*, **53**: 48–55.
- Tsai KC, Chen HW and Hong CP, et al. (1993), "Design of Steel Triangular Plate Energy Absorbers for Seismic-resistant Construction," *Earthquake Spectra*, **9**(3): 505–528.
- Tsopelas P, Constantinou MC, Kim YS and Okamoto S (1996), "Experimental Study of FPS System in Bridge Seismic Isolation," *Earthquake Engineering & Structural Dynamics*, **25**(1): 65–78.
- Tyler RG (1978), "Tapered Steel Energy Dissipators

for Earthquake Resistant Structures,” *Bulletin of New Zealand National Society for Earthquake Engineering*, **11**(4): 282–194.

Tyler RG (1985), “Further Notes on Steel Energy-absorbing Element for Braced Frameworks,” *Bulletin of New Zealand National Society for Earthquake Engineering*, **18**(3): 270–279.

Vader TS and McDaniel CC (2007), “Influence of Dampers on Seismic Response of Cable-supported Bridge Towers,” *Journal of Bridge Engineering*, **12**(3): 373–379.

Villaverde R (2009), *Fundamental Concepts of Earthquake Engineering*, CRC Press, INC., California.

Yao JTP (1972), “Concept of Structural Control,” *Journal of the Structural Division, ASCE*, **98**(ST7): 1567–1574.

Ye AJ, Xu LP, Zhang XG and Fan LC (2005), “A Structural System for Controlling Longitudinal Movements of a Super Long-span Cable-stayed Bridge,” *Journal*, (Issue): 103–113.

Zhang XD, Li HN, Feng XT and Chen ZH (2012), “Seismic Response of Bridge Isolated with Friction Pendulum Systems,” *Proceedings of the 2nd International Conference on Civil Engineering and Transportation ICCET 2012*, 256, Guilin, China, 2122–2126.