



US 20140322059A1

(19) **United States**
(12) **Patent Application Publication**
Kovacevic et al.

(10) **Pub. No.: US 2014/0322059 A1**
(43) **Pub. Date: Oct. 30, 2014**

(54) **FLUID MACHINE**

Publication Classification

(75) Inventors: **Ahmed Kovacevic**, Barnet (GB);
Nsikan Udo, Glasgow (GB)

(51) **Int. Cl.**
F04C 29/00 (2006.01)
F04C 18/08 (2006.01)
(52) **U.S. Cl.**
CPC **F04C 29/005** (2013.01); **F04C 18/082** (2013.01)
USPC **418/201.1**; **418/206.7**

(73) Assignee: **Howden Compressors Limited**,
Strathlyde (GB)

(21) Appl. No.: **14/115,559**

(57) **ABSTRACT**

(22) PCT Filed: **May 3, 2012**

(86) PCT No.: **PCT/GB2012/050967**

§ 371 (c)(1),
(2), (4) Date: **Nov. 4, 2013**

The present disclosure relates to fluid machines, especially compressors, more especially screw compressors. More particularly the present disclosure describes a fluid machine comprising at least one rotor (64), the rotor including a rotor drive shaft (68) extending from the rotor, a housing in which is mounted the rotor, and at least one bearing insert (74) which mounts around the rotor drive shaft at a first end of the rotor and which includes at least one bearing (114) within it and attaches to the housing. The present disclosure also describes bearing inserts suitable for use on such fluid machines.

(30) **Foreign Application Priority Data**

May 5, 2011 (GB) 1107451.5

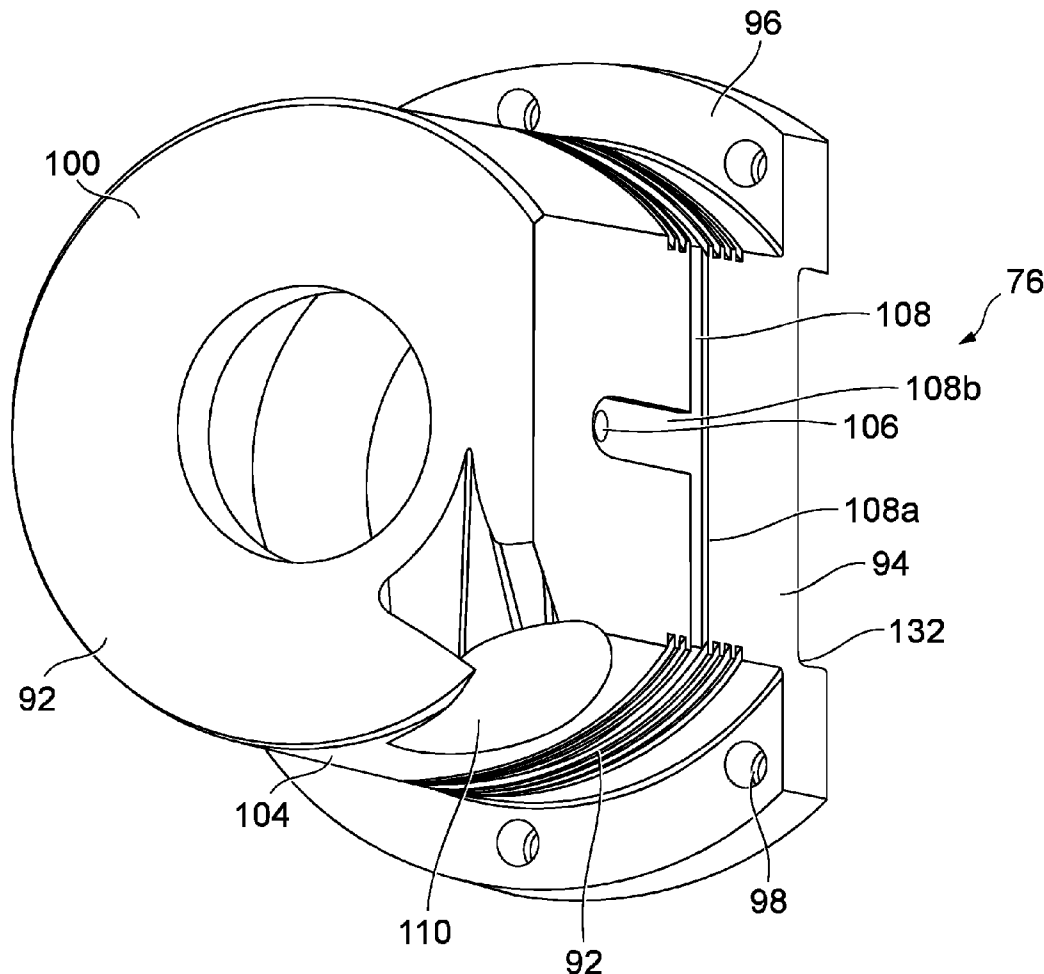

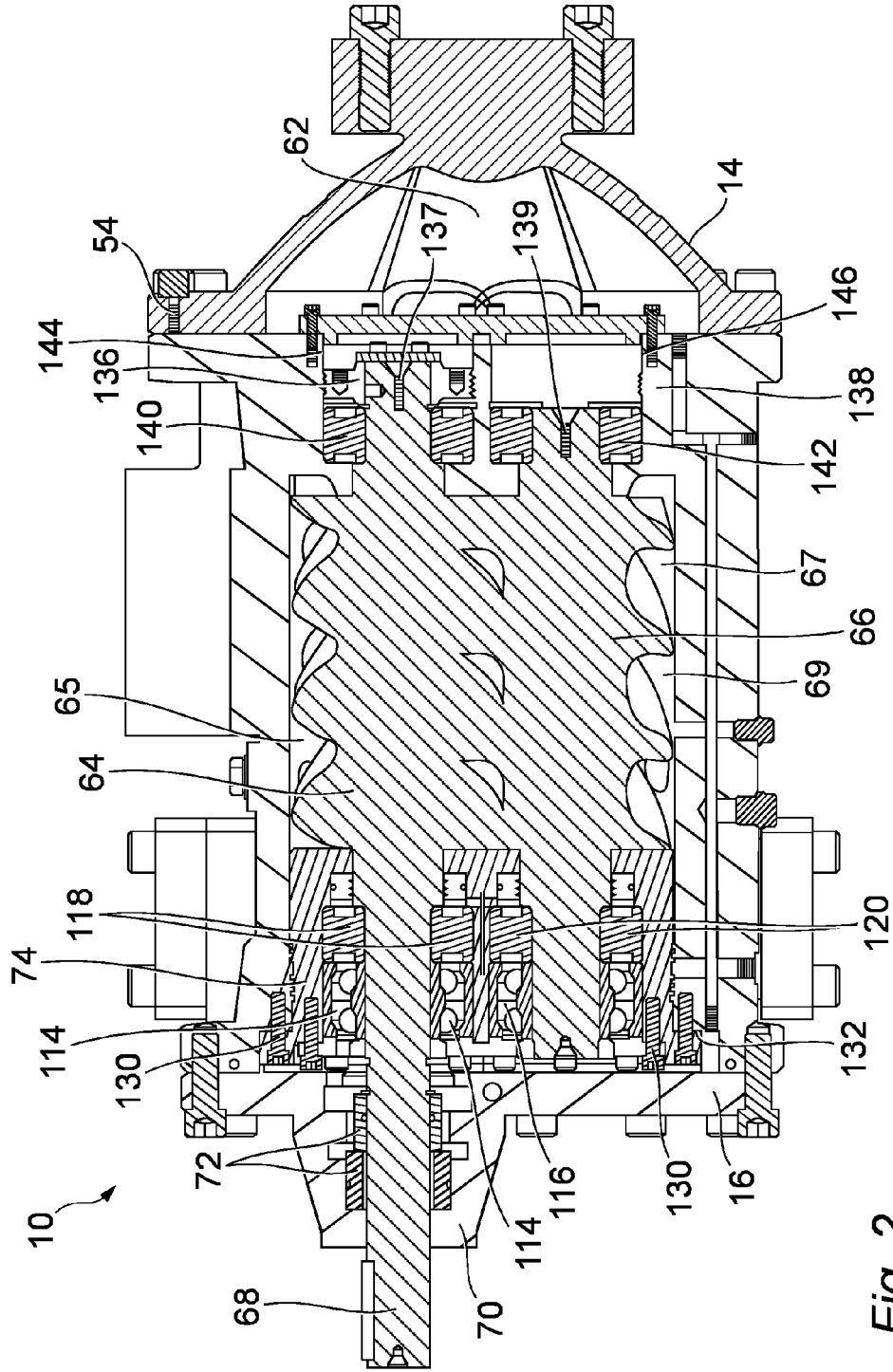

Fig. 2

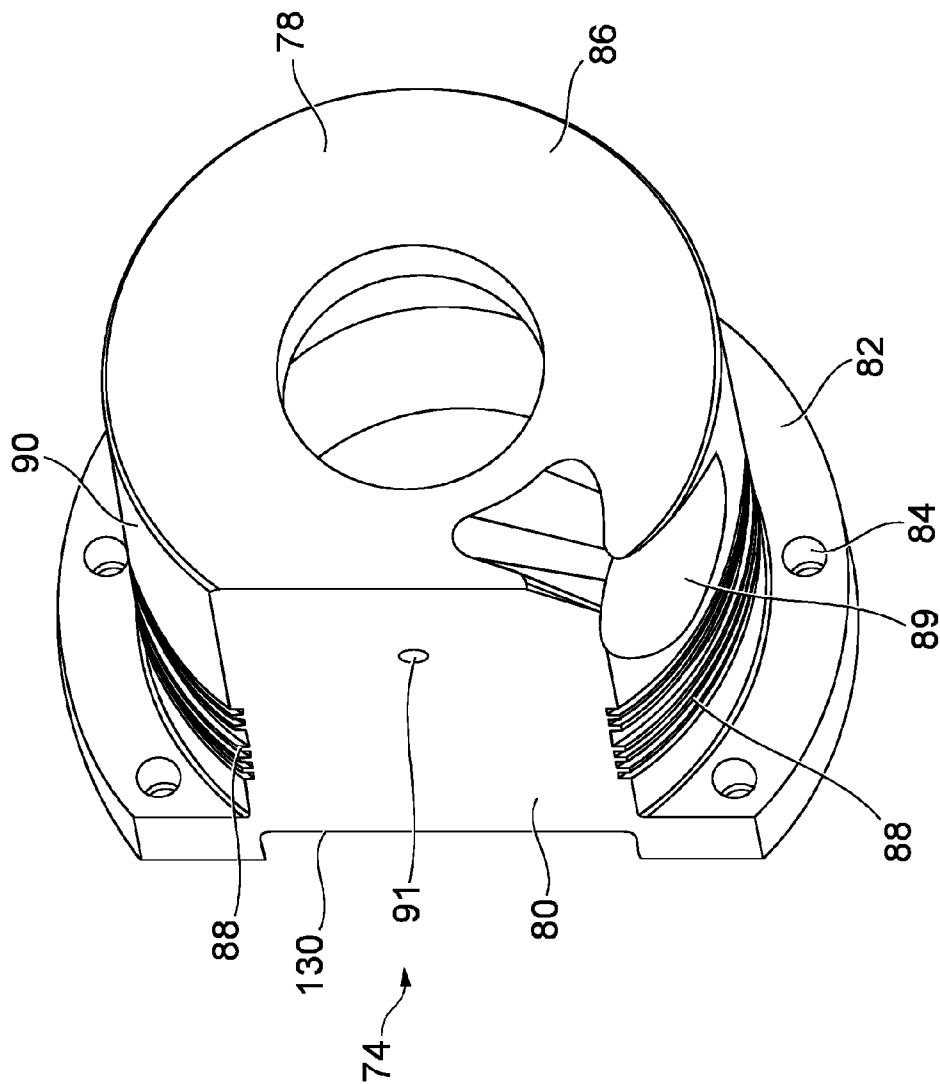

Fig. 3

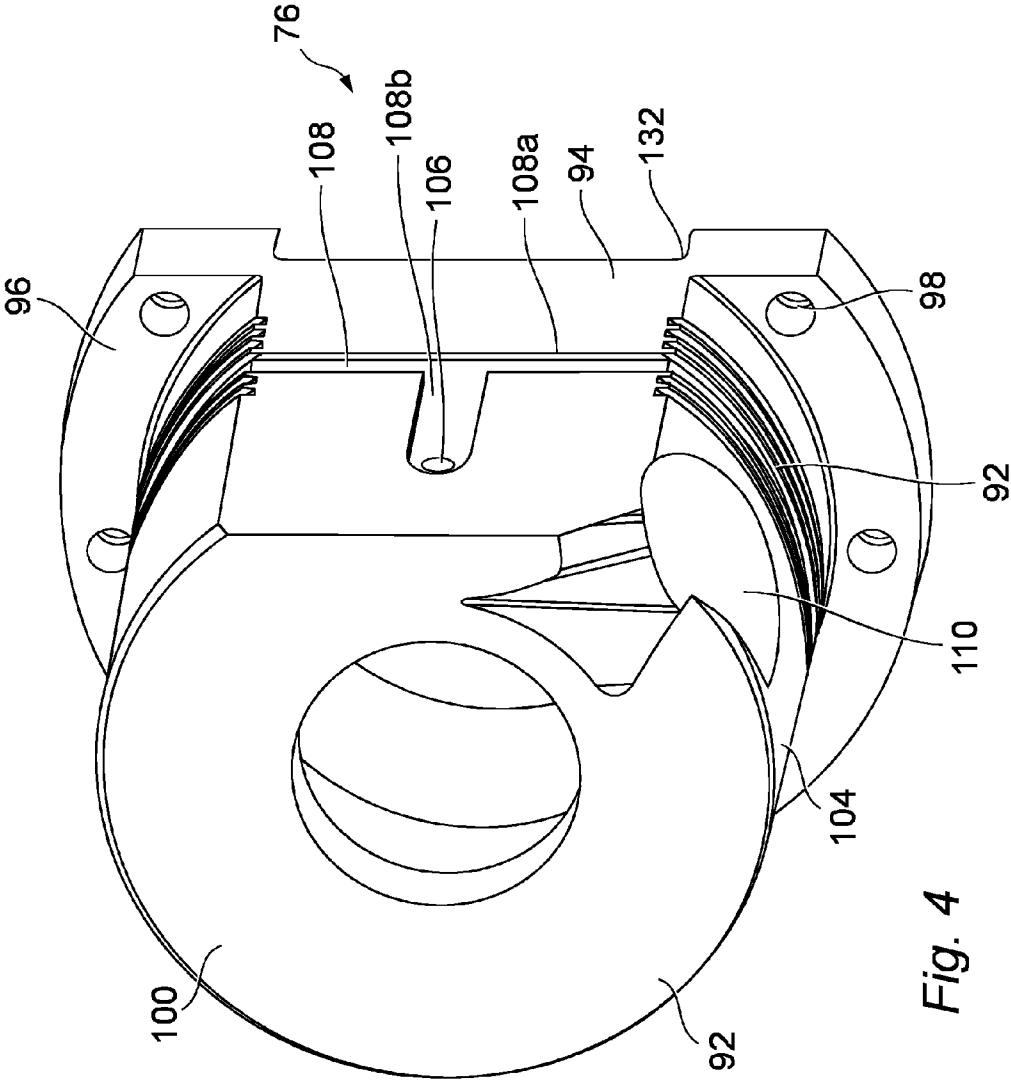

Fig. 4

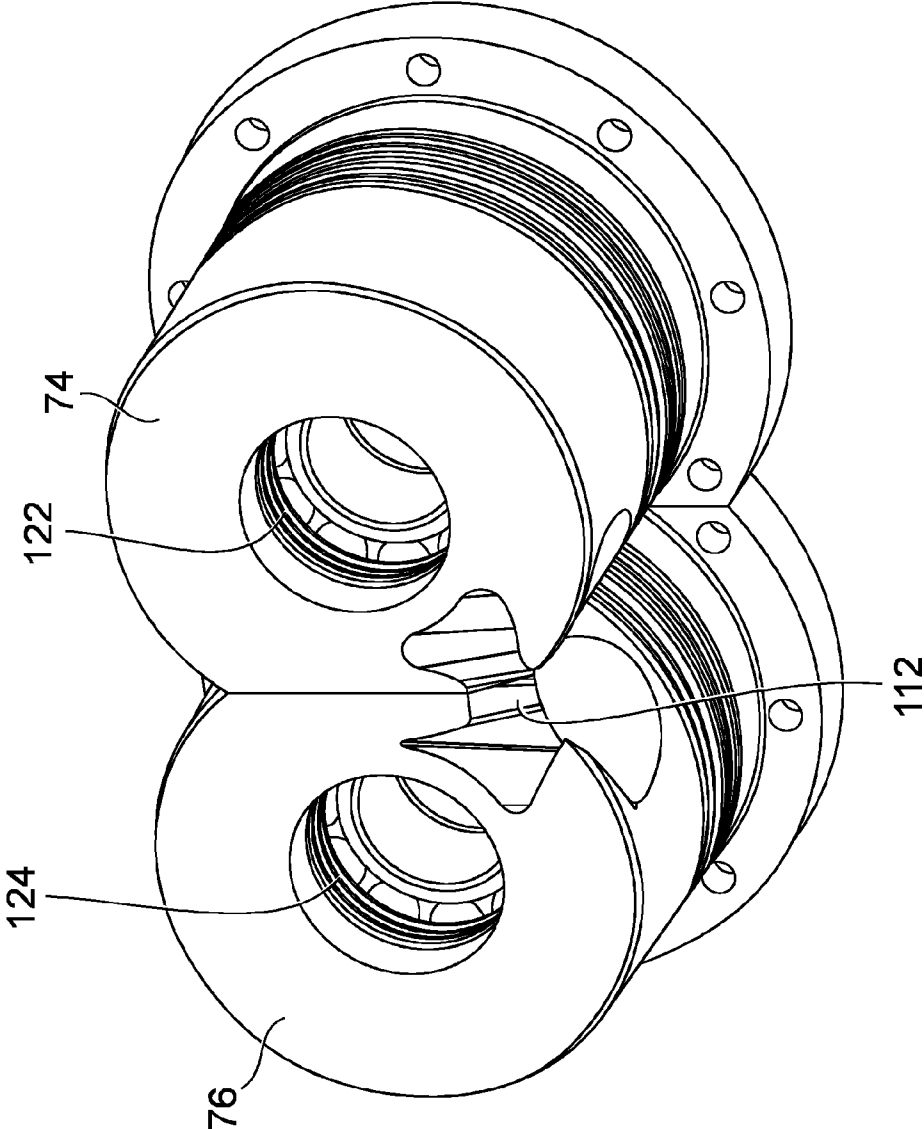

Fig. 5

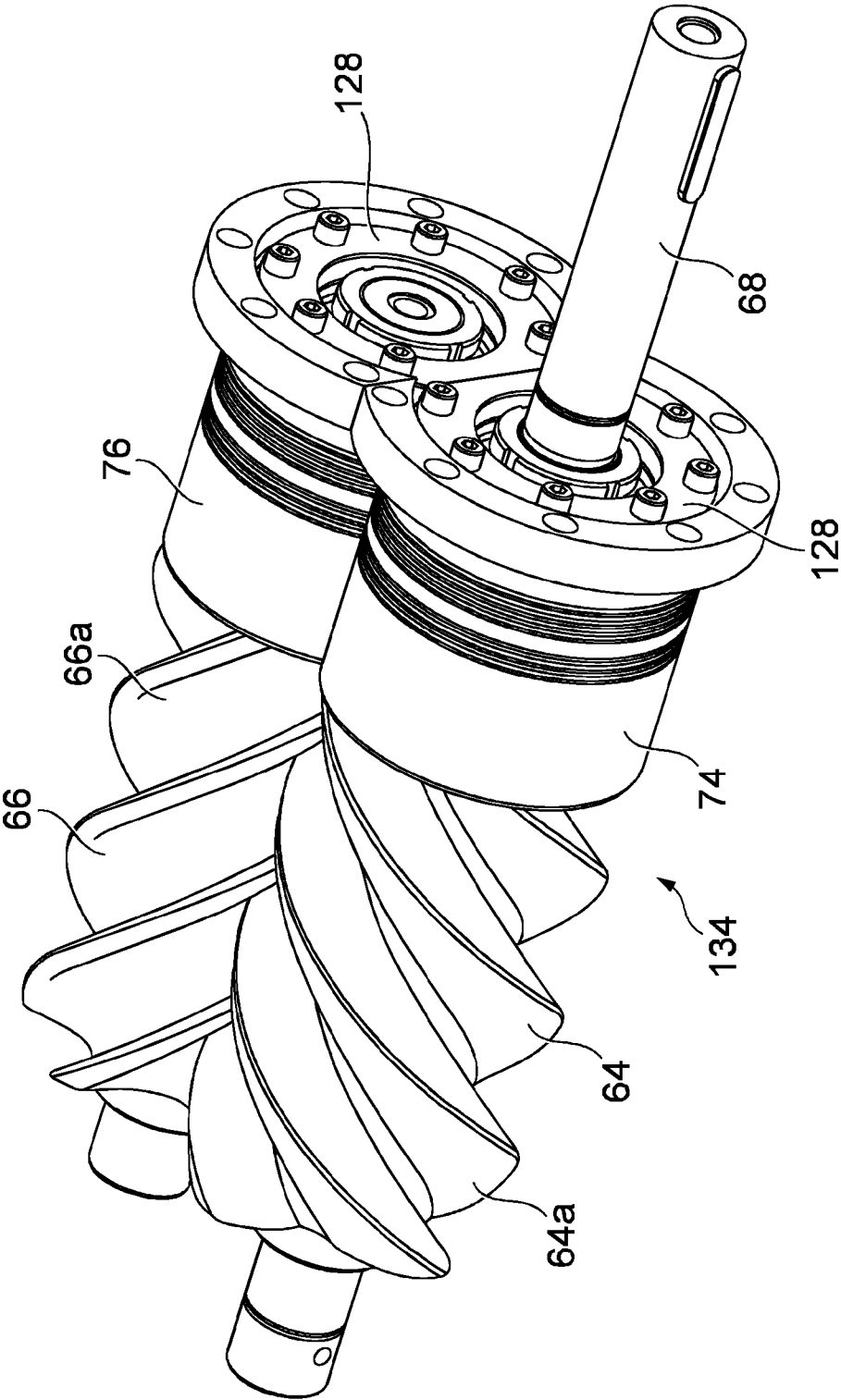

Fig. 6

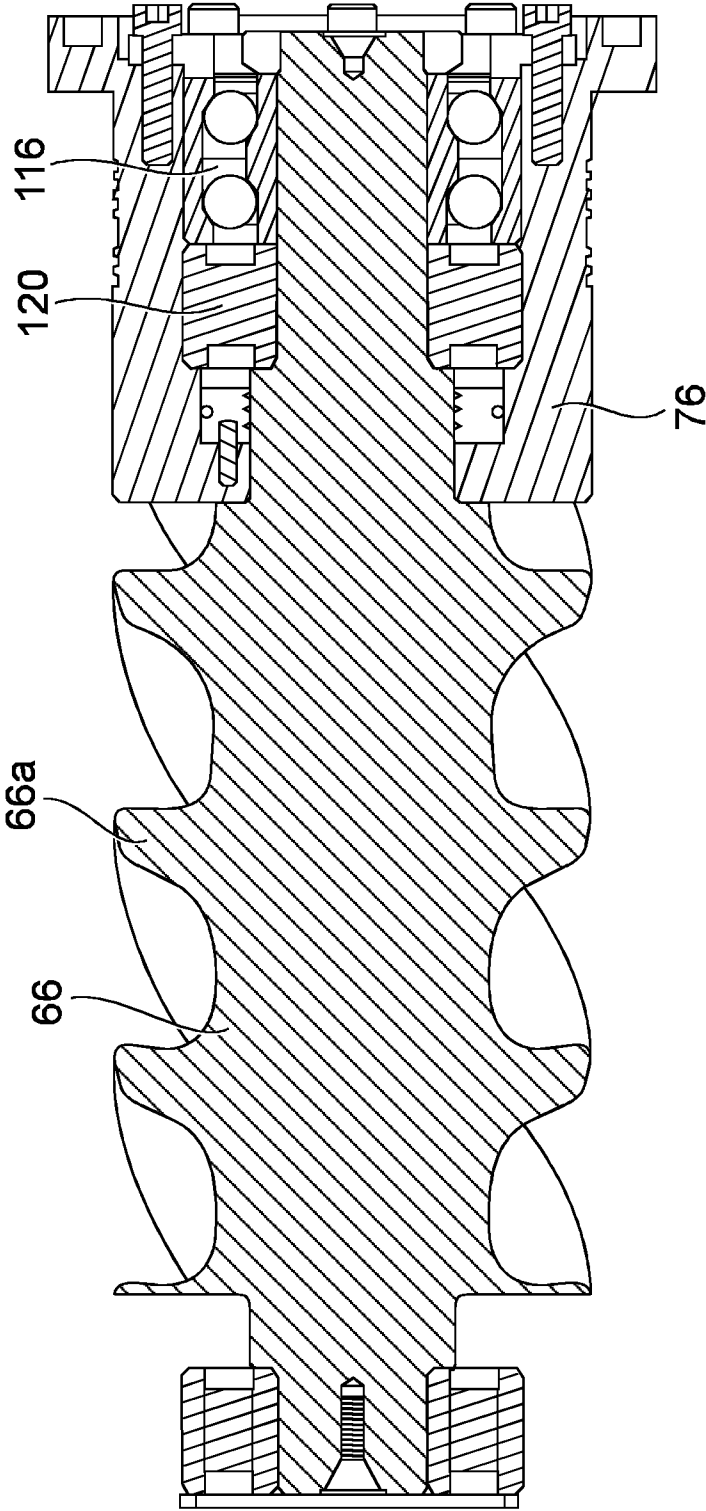

Fig. 7

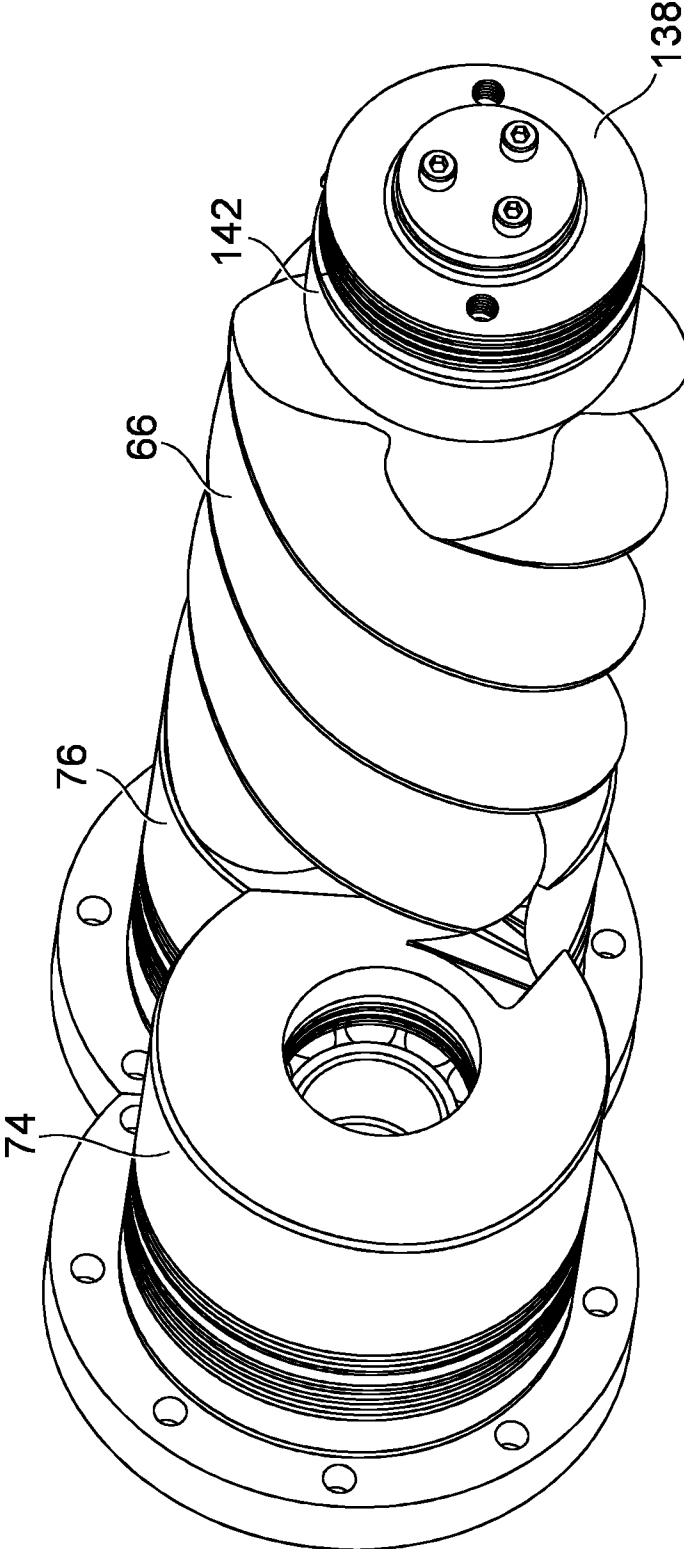

Fig. 8

FLUID MACHINE

FIELD OF THE INVENTION

[0001] The present invention relates to fluid machines, especially compressors, more especially screw compressors.

BACKGROUND OF THE INVENTION

[0002] Screw compressors will usually comprise two helical compressor rotors which closely mesh within a compressor housing. There is a female and a male rotor, which are mounted with the spirals of their respective helices orientated in opposite directions. The rotors are driven and as they rotate, fluid is trapped in the space between the rotors and the housing. This enables the fluid to be compressed by the action of the rotors.

[0003] The casings of such screw compressors generally comprise three separate sections: a main central housing, an inlet housing and an outlet housing. In some case, two of these components may be combined into one contiguous piece, such as the inlet casing and the main casing. All three of these are structural elements i.e. they bear load transmitted through bearings.

[0004] The inlet and outlet housings will have mounts for the rotor shafts, with the main bodies of the rotors mounted within conjoined rotor chambers. Since the rotors may rotate at high speed and require precise tolerances to enable correct operation, thrust and radial bearings are used to maintain correct relative positioning.

[0005] Compressing the gas creates a pressure load that is borne by the rotors.

[0006] Compressing fluids creates heat and this heat causes expansion of the materials used to manufacture the housings and rotors. Since they may be formed from different materials, are different shapes and are exposed to varying temperatures, the rotors and the casings will not expand uniformly, and hence a thermal load is created by the rotors expanding longitudinally against the mounts.

[0007] The three housings are connected to one another usually be arrangements of flanges and bolts, and the loads acting upon the system must be resisted by these arrangements.

SUMMARY OF THE INVENTION

[0008] According to a first aspect of the present invention there is provided a fluid machine comprising at least one rotor, the rotor including a rotor drive shaft extending from the rotor, a housing in which is mounted the rotor, and at least one bearing insert which mounts around the rotor drive shaft at a first end of the rotor and which includes at least one bearing within it and attaches to the housing.

[0009] The term "fluid machine" will be understood to include, without limitation, pumps, compressors, turbines and expanders.

[0010] The rotor will have lobes or blades projecting from the rotor drive shaft to a maximum diameter, and the bearing inserts may have a dominant dimension, measured substantially perpendicularly to a main axis of the rotor shaft, that is substantially the same as said maximum diameter.

[0011] The fluid machine may be a screw compressor, the rotor being a screw type with helical lobes surrounding a rotor drive shaft, and the dimension of the bearing insert is substantially the same as that of the maximum helical lobe diameter.

[0012] The fluid machine may include two meshing rotors.

[0013] The fluid machine may include two bearing inserts. The bearing inserts may be joined along a sidewall.

[0014] The bearing insert may be substantially cylindrical. The bearing insert may have a flattened portion on a cylindrical sidewall for mating with another bearing insert.

[0015] The bearing insert may include a flange for attaching the bearing insert to the housing. The bearing insert may include a fluid machine port formed in it. This may be in the form of an external indentation on one or more exterior sidewalls. Two or more bearing inserts may have cooperating indentations to form a fluid machine port. This port may be a suction, discharge or other

[0016] The bearing insert may include at least one thrust bearing and at least one radial bearing within it.

[0017] The rotors may have bearing inserts on both first and second ends.

[0018] The rotors may be further mounted within the housing at an end opposite the bearing insert with an axial biasing device, which may be a balance piston. A bearing may be provided adjacent the axial biasing device.

[0019] According to a second aspect of the present invention there is provided a bearing insert suitable for use with a fluid machine, comprising a substantially tubular body with a central bore, the central bore including at least one internally mounted bearing, with a bearing surface exposed within the central bore.

[0020] The bearing insert may include an attachment flange around a first end of the tubular body.

[0021] The bearing insert may have a flattened portion on a cylindrical sidewall for mating with another bearing insert.

[0022] The bearing insert may include a port formed in it. This may be in the form of an external indentation on an exterior sidewall. Two or more bearing inserts may have cooperating indentations to form a port. This may be a high pressure port.

[0023] The bearing insert may include at least one thrust bearing and at least one radial bearing within it.

BRIEF DESCRIPTION OF THE DRAWINGS

[0024] An example of the present invention will now be described, by way of example only, with reference to the following drawings, in which:

[0025] FIG. 1 is a side elevation of a fluid machine, namely a screw compressor, according to the present invention;

[0026] FIG. 2 is a plan sectional view of the compressor of FIG. 1;

[0027] FIG. 3 is a perspective view of a male bearing insert of the compressor of FIG. 1;

[0028] FIG. 4 is a perspective view of a female bearing insert of the compressor of FIG. 1;

[0029] FIG. 5 is a perspective view of the male bearing insert of FIG. 3 attached to the female bearing insert of FIG. 4;

[0030] FIG. 6 is a perspective view of the joined bearing inserts of FIG. 5 with male and female rotors inserted;

[0031] FIG. 7 is a sectional side elevation of the female rotor and bearing insert arrangement of the compressor of FIG. 1; and

[0032] FIG. 8 is a further perspective view of the arrangement of FIG. 6 with the female rotor in transparent section.

[0033] A screw compressor 10 is shown in FIG. 1. It comprises a housing 12, an inlet cover 14 and an outlet cover 16. The housing 12 is a generally cylindrical shape, with a first

flange 18 at the inlet end 20 and a second flange 22 at the outlet end 24. Mounting feet 26 project from a lower surface 28 of the housing 12 and are adjacent inlet end 20 and outlet end 24. Approximately diametrically opposite the mounting feet 26, on an upper surface 30 of the housing 12 and adjacent inlet end 20 and outlet end 24 are mounting lugs 32. The mounting lugs 32 comprise a radially projecting plate 34, the plane of the plate 34 being substantially parallel to a horizontal axis of the screw compressor 10 cylindrical housing 12. In each plate 34 is an aperture 36 adjacent a chamfered corner 38 of the plate 34, the chamfered corner 38 being disposed axially inboard and radially outward of the housing 12.

[0034] Located at the approximate axial midpoint of the housing 12 around the upper surface 30, are radial strengthening ribs. Six strengthening ribs 40 are provided on the present embodiment. The strengthening ribs 40 form a contiguous arrangement with an axial strengthening spine 42, the spine 42 also being contiguous with the mounting lugs 32.

[0035] An outlet port 44 projects radially from the housing 12 adjacent the lower surface 28. The outlet port 44 has a substantially square outlet plate cover 46 attached to it.

[0036] The inlet cover 14 includes an inlet cover flange 48 which attaches to the first flange 18 with mechanical fasteners i.e. nuts 50 which attach to threaded bolts 54 that project from the first flange 18. A substantially offset frustum-shaped body 52 extends from the inlet cover flange 48, and is offset towards the upper surface 30 of the housing 12. A mounting flange 56 with attached cover 58 is disposed at the distal end of the inlet cover 14 from the inlet cover flange 48. Mechanical fasteners in the form of threaded bolts 60 attach mounting flange 56 to cover 58.

[0037] An inlet duct 62 is defined within the inlet cover 14 and is in the form of a largely conical channel, which allows for fluid communication between a bore (not shown) at the centre of the mounting flange 56 and the internal components of the compressor 10.

[0038] A male rotor 64 and female rotor 66 are provided within the housing 12. The male rotor 64 and female rotor 66 are meshed, similar to prior art compressors. The male rotor 64 and female rotor 66 are housed within adjoined cylindrical cavities 65, 67 within the housing 12 that overlap to form a conjoined cavity 69 with a "figure eight" cross-section. The sidewalls of the cavity 69 are very close in diameter to the outer diameter of each rotor 64,66 such that there is minimal clearance, but the rotors 64,66 are not impeded from rotating.

[0039] A drive shaft 68 extends from the male rotor 64 and projects from the outlet cover 16 of the compressor 10. This will be driven by a rotational motor (not shown), which may be electrical or mechanical or some other type, to power the compressor 10. This projects through outlet cover 16, which is a substantially circular plate member, with circumferential bores to enable its attachment to the housing 12 via second flange 22. On the surface of the outlet cover 16 opposite the housing 12 from which the drive shaft 68 projects, and disposed around the base of the drive shaft 68 is a shaft cover 70. The shaft cover 70 is a substantially frusto-conical shape, with the greater diameter end abutting the outlet cover 16. Shaft bearings 72 are provided within the shaft cover 70 and around the drive shaft 68.

[0040] A male bearing insert 74 is provided around the base of the male rotor 64. The male bearing insert 74 is located adjacent the shaft cover 70 on the inside of the compressor 10.

[0041] A female bearing insert 76 is provided the base of the female rotor 66. Both bearing inserts 74 and 76 are cov-

ered by the outlet cover 16 but neither are connected nor abut the outlet cover 16. Consequently, neither rotor 64,66 is structurally dependent upon the outlet cover 16 nor will act upon it under load.

[0042] Male bearing insert 74 comprises a generally tubular main body 78 that is radially truncated to form a planar male mating face 80. A male bearing insert flange 82 is provided around a first end of the male bearing insert 74, the flange 82 also being truncated to form the male mating face 80. The flange 82 is provided with a plurality of flange attachment apertures 84 around its circumference. At a second end of the male bearing insert 74, located distally from the first end, is a male rotor annulus 86. A male insert labyrinth seal 88 is provided adjacent the flange 82, and is disposed on the sidewall 90 of the tubular main body 78. The labyrinth seal 88 intersects the male mating face 80. A male insert attachment aperture 91 is provided on the male mating face 80, located axially towards the male rotor annulus 86, but at the approximate diametric centre of the tubular main body 78 and male mating face 80.

[0043] A male outlet port 89 is formed adjacent the male mating face 80 and the male rotor annulus 86. The male outlet port 89 intersects both the male mating face 80 and the male rotor annulus 86 such that fluid flow is permitted through the port 89 from outside male mating face 80 through the tubular main body 78 and out the male rotor annulus 86, towards the male rotor 64.

[0044] Female bearing insert 76 comprises a generally tubular main body 92 that is radially truncated to form a generally planar female mating face 94. A female bearing insert flange 96 is provided around a first end of the female bearing insert 76, the flange 96 also being truncated to form the female mating face 94. The flange 96 is provided with a plurality of flange attachment apertures 98 around its circumference. At a second end of the female bearing insert 76, located distally from the first end, is a female rotor annulus 100. A female insert labyrinth seal 102 is provided adjacent the flange 96, and is disposed on the sidewall 104 of the tubular main body 92. The labyrinth seal 102 intersects the female mating face 94.

[0045] A female insert attachment aperture 106 is provided on the female mating face 94, located axially towards the female rotor annulus 100, but at the approximate diametric centre of the tubular main body 92 and female mating face 94. The female insert attachment aperture 106 is located within a T-shaped groove 108 formed in the female mating face 94. The T-shaped groove 108 is located with the upper cross groove 108a projecting diametrically across the female mating face 94 and in fluid communication with the labyrinth seal 102, and the lower groove 108b projecting from the midpoint of the upper cross groove 108a, axially along the female mating face 94, but terminating within the confines of the female mating face 94. The female insert attachment aperture 106 is located at the base of the lower groove 108b, the base of the lower groove 108b having a rounded lower extremity.

[0046] A female outlet port 110 is formed adjacent the female mating face 94 and the female rotor annulus 100. The female outlet port 106 intersects both the female mating face 94 and the female rotor annulus 100 such that fluid flow is permitted through the port 106 from outside female mating face 94 through the tubular main body 92 and out the female rotor annulus 100, towards the female rotor 66.

[0047] FIG. 5 shows the male bearing insert 74 attached to the female bearing insert 76. The inserts 74,76 are attached

along their corresponding mating faces **80,94** with a mechanical fastener (not shown) attaching them via their respective attachment apertures **91,106**. This forms a largely contiguous insert arrangement, with a largely “figure eight” cross-section.

[0048] The male outlet port **89** and female outlet port **106**, having corresponding location on their respective bearing inserts **74,76**, cooperate to form a combined outlet port **112**.

[0049] Bearings are provided within the bearing inserts **74,76**. Two bearings are provided in each bearing insert **74,76** in the present embodiment. Adjacent the first ends and within each bearing insert **74,76** is provided a thrust bearing, respectively numbered **114** (male bearing insert thrust bearing **114**) and **116** (female bearing insert thrust bearing **116**). The thrust bearings **114,116** are a ball bearing type.

[0050] Adjacent the thrust bearings **114,116** and located towards the rotors **64,66** are radial bearings, respectively numbered **118** (male bearing insert radial bearing **118**) and **120** (female bearing insert radial bearing **120**). The radial bearings **118,120** are a friction bearing type.

[0051] Adjacent the radial bearings **118,120** and located towards the rotors **64,66** are inner labyrinth seals, respectively numbered **122** (male bearing insert inner labyrinth seal **122**) and **124** (female bearing insert inner labyrinth seal **122**).

[0052] Adjacent the thrust bearings **114, 116** are provided removable inner flange rings respectively numbered **126** (male bearing inner flange ring **126**) and **128** (female bearing inner flange ring **128**). The thrust bearings **114,116**, radial bearings **114,116** and inner labyrinth seals **122,124** are held within their respective bearing inserts **74,76** between the rotor annuli **86,100** and the removable inner flange rings **126,128**.

[0053] The removable inner flange rings **126,128** have a similar cross sections to the bearing inserts themselves, and attach to the ends of the bearing inserts with mechanical fasteners **130** that attach to insert lips **130,132** provided adjacent the flanges **82,96**.

[0054] The rotors **64,66** are mounted into the bearing insert assembly **74,76** at a first end of both rotors with the rotor annuli **86,100** facing lobes **64a,66a** of the rotors **64,66**. The combined outlet port **112** is therefore in direct fluid communication with the rotors **64,66** and rotor lobes **64a,66a**.

[0055] The rotors **64,66** and bearing insert assembly **134** (seen in FIG. 6) may then be mounted within the housing **12**. The bearing insert assembly **134** is mounted into the conjoined cavity **69** at the outlet end **24**. A cavity lip (not shown) co-operable with the bearing insert flanges **82,96** is provided around the entry to the conjoined cavity **69**. Mechanical fasteners attach the bearing insert flanges **82,96** to the cavity lip and therefore the housing **12**.

[0056] Balance pistons **136,138** are mounted on the distal end of the male and female rotors **64,66**; that is, the end opposite the bearing inserts **74,76**. Mechanical fasteners **137, 139** are used to mount the balance pistons **136,138** to the Further balance piston side radial bearings **140,142** are also mounted around the distal end of the male and female rotors **64,66**, adjacent the balance pistons **136,138** but inboard of them; that is, between balance pistons **136,138** and rotor lobes **64a,66a**.

[0057] The balance pistons **136,138** mount within corresponding sockets **144,146** within each cavity **65,67** at the inlet end **20**, ensuring axial alignment of the rotors **64,66** at that end **20** of the housing **12** together with the balance piston side radial bearings **140,142**.

[0058] On the housing **12** there is also provided a variable Volume Index (VI) control slider valve **148** to control Volume Index and two poppet valves **150** which provide capacity control. The control slider valve includes a manual control mechanism **152** which extends from the inlet end **20** out of the housing **12**. The manual control mechanism **152** comprises a slider and threaded rod mechanism, which may be controlled manually or automatically, with a stepper motor (not shown) for example.

[0059] In use, an external motor drives the drive shaft **68**. This causes the male rotor **64** to rotate within cavity **65** and imparts this rotational motion to female rotor **66** via the respective rotor lobes **64a,66a**.

[0060] Fluid is drawn into the interlobe space from the inlet end **20** through the inlet duct **62**. As the rotor lobes **64a,66a** mesh fluid is trapped and compressed as it is forced along the rotors **64,66** from inlet end **20** to outlet end **24**. Eventually, the interlobe space occupied by the fluid is forced through the combined outlet port **112** formed on the bearing insert assembly **74,76** and exposed to outlet port **44**, through which the fluid is discharged.

[0061] This process imparts three main loads to the rotors: a drive load from the motor driving the drive shaft; a pressure load from the fluid being compressed in the interlobe spaces and a thermal load as a temperature rise will result from the compression process causing components to expand, including the rotors **64,66**.

[0062] In prior art machines, these loads would be borne by the main structural components of a three-part casing: a main housing, an inlet housing and an outlet housing.

[0063] These loads are now borne by the housing **12** alone, and the inlet cover **14** and outlet cover **16**, being non-structural, may be composed of different materials. Any expansion or loading of rotors **64,66** is partially or wholly accommodated by the bearing inserts **74,76** and the balance pistons **136,138**.

[0064] The dimensions and shape of the combined outlet port **112** will have a bearing on flow characteristics and may need to be altered to optimise functioning of the compressor **10**. These may be altered by replacing the bearing inserts **74,76** with others having differently shaped and/or sized male outlet port **89** and female outlet port **106** combining to form a differently dimensioned and/or shape of the combined outlet port **112**.

[0065] Although described with particular reference to a screw compressor, it will be understood that the present invention may find utility in other fluid machines, which may include, without limitation, pumps, compressors, turbines and expanders.

[0066] By having only one housing the manufacturing process is simplified and misalignments which normally were an issue with three housings are minimised. It is because the inserts have essentially the same diameter as the casing and since both of these are manufactured in one machining operation each it mitigates misalignment.

[0067] By the design of bearing inserts which contain bearings and locknuts to locate rotors, substantially all axial forces are contained between the rotor and the insert and are not transmitted to other parts of the machine. That means inserts carry substantially all axial loads whilst the main housing carries substantially just radial loads. Therefore excluding rotors, all other parts of the machine are not subjected to significant loads.

[0068] The design of inserts allows subassembly of rotor and insert to be removed from the machine and adjusted externally for appropriate functionality of the machine. This makes the fluid machine flexible and easy to maintain.

[0069] Bearing inserts on the inside contain bearings and locking devices to keep rotors in position while on the outside they contain ports which could be flexibly manufactured and changed and do not require any other alterations in the machine to adapt it for different applications.

[0070] It has also been found that the hereinbefore described embodiment of the present invention provides appreciable improvements in both volumetric efficiency and reduction in noise over prior art devices.

[0071] Moreover, the invention is not limited to its application on screw type machines only, but may find application in all rotary-typeshaft-based designs, including, again without limitation, fan, scroll and centrifugal.

[0072] The invention is not limited to the embodiments hereinbefore described, but may modified without departing from the scope of the present invention.

[0073] For example, bearing inserts may be provided on both ends of the rotor, replacing or being in addition to the balance pistons.

1-22. (canceled)

23. A fluid machine comprising at least one rotor, the rotor including a rotor drive shaft extending from the rotor, a housing in which is mounted the rotor, and at least one bearing insert which mounts around a rotor drive shaft at a first end of the rotor and which includes at least one bearing within it and attaches to the housing; wherein the rotor has lobes or blades projecting from the rotor drive shaft to a maximum diameter, and the bearing inserts have a dominant dimension, measured substantially perpendicularly to a main axis of the rotor shaft, that is substantially the same as said maximum diameter.

24. A fluid machine according to claim 23, wherein the fluid machine is a screw compressor, the rotor being a screw type with helical lobes surrounding a rotor drive shaft, and the dimension of the bearing insert is substantially the same as that of the maximum helical lobe diameter.

25. A fluid machine according to claim 23, wherein the fluid machine includes two meshing rotors.

26. A fluid machine according to claim 23, wherein the fluid machine may include two bearing inserts.

27. A fluid machine according to claim 26, wherein the bearing inserts are joined along a sidewall.

28. A fluid machine according to claim 26, wherein the two bearing inserts each include at least one thrust bearing for balancing axial pressure loads applied to the two meshing rotors.

29. A fluid machine according to claim 23, wherein the bearing insert is substantially cylindrical.

30. A fluid machine according to claim 29, wherein the bearing insert has a flattened portion on a cylindrical sidewall for mating with another bearing insert.

31. A fluid machine according to claim 23, wherein the bearing insert includes a flange for attaching the bearing insert to the housing.

32. A fluid machine according to claim 23, wherein the bearing insert includes a port formed in it.

33. A fluid machine according to claim 32, wherein the port is in the form of an external indentation on one or more exterior sidewalk.

34. A fluid machine according to claim 23, wherein the bearing insert includes at least one thrust bearing and at least one radial bearing within it.

35. A fluid machine according to claim 23, wherein a further bearing insert is mounted around a second end of the rotor.

36. A fluid machine according to claim 23, wherein the at least one bearing insert is configured such that substantially all axial forces are contained between the rotor and the bearing insert and are not transmitted to other parts of the fluid machine.

37. A bearing insert suitable for use with a fluid machine, comprising a substantially tubular body with a central bore, the central bore including at least one internally mounted bearing with a bearing surface exposed within the central bore; wherein the bearing insert includes a port formed in it.

38. A bearing insert according to claim 37, including an attachment flange around a first end of the tubular body.

39. A bearing insert according to claim 37, including a flattened portion on a cylindrical sidewall for mating with another bearing insert.

40. A bearing insert according to claim 37, wherein the port is formed by an external indentation on an exterior sidewall.

41. A bearing insert according to claim 37, including at least one thrust bearing and at least one radial bearing within it.

42. A bearing insert according to claim 41, wherein the at least one thrust bearing is configured to balance axial loads applied to the at least one rotor such that the at least one bearing insert carries substantially all axial loads from the rotor.

* * * * *