



City Research Online

City, University of London Institutional Repository

Citation: Rogalsky, M.R. (2006). Idea and community : the growth of David Tudor's Rainforest, 1965-2006. (Unpublished Doctoral thesis, City University London)

This is the accepted version of the paper.

This version of the publication may differ from the final published version.

Permanent repository link: <https://openaccess.city.ac.uk/id/eprint/8493/>

Link to published version:

Copyright: City Research Online aims to make research outputs of City, University of London available to a wider audience. Copyright and Moral Rights remain with the author(s) and/or copyright holders. URLs from City Research Online may be freely distributed and linked to.

Reuse: Copies of full items can be used for personal research or study, educational, or not-for-profit purposes without prior permission or charge. Provided that the authors, title and full bibliographic details are credited, a hyperlink and/or URL is given for the original metadata page and the content is not changed in any way.

**IDEA AND COMMUNITY: THE GROWTH OF
DAVID TUDOR'S *RAINFOREST*, 1965-2006**

Matthew R. Rogalsky

Submitted for the qualification
of Doctor of Philosophy

City University London
Music Department

April 2006

TABLE OF CONTENTS

List of tables and illustrations	3
List of tracks on accompanying audio CD	10
Acknowledgements	13
Declaration re: copying	15
Abstract	16
Introduction	17
1. Contextualising <i>Rainforest</i>	34
2. Preludes to <i>Rainforest</i> : <i>Fluorescent Sound</i> (1964) and <i>Bandoneon !</i> (1966)	58
3. Entering <i>Rainforest</i> : Versions 1 (1968) and 2 (1969-70)	90
4. The Pepsi Pavilion (1970) and <i>Rainforest 3</i> (1972)	148
5. <i>Rainforest 4</i> (1973) and the development of a performance community	182
6. Composers Inside Electronics: Formalising the <i>Rainforest</i> community, 1974-1982	261
7. After David Tudor: the Future of <i>Rainforest</i> and Composers Inside Electronics	387
Appendix: Performances of <i>Rainforest 1</i> with Merce Cunningham Dance Company, 1968-2003 Performances of <i>Rainforest 3</i> (European Tour 1972) Performances of <i>Rainforest 4</i> by Composers Inside Electronics Other Composers Inside Electronics performances / residencies	449
Combined bibliography and list of references	464
List of interviews	492
Discography	494

LIST OF TABLES AND ILLUSTRATIONS

Figure 2-1. David Tudor performing John Cage's <i>Water Music</i> , "5 New York Evenings", Moderna Museet, Stockholm September 10 1964.	63
Figure 2-2. Robert Rauschenberg performing <i>Elgin Tie</i> , "5 New York Evenings", Moderna Museet, Stockholm September 13 1964. Note recessed banks of fluorescent lights overhead, used by David Tudor for accompanying piece <i>Fluorescent Sound</i>	65
Figure 2-3. Robert Rauschenberg performing <i>Elgin Tie</i> , "5 New York Evenings", Moderna Museet, Stockholm September 13 1964. Note recessed banks of fluorescent lights overhead, used by David Tudor for accompanying piece <i>Fluorescent Sound</i>	66
Figure 2-4. Poster for "Projects Outside Art" initiative, Experiments in Art and Technology 1969-1971, employing rainforest imagery.	70
Figure 2-5. "Build a fantastic coneless loudspeaker!" (<i>Popular Mechanics</i> , 1966).	74
Figure 2-6. Notes for <i>Bandoneon !</i> , from the programme book for 9 Evenings: Theatre and Engineering.	76
Figure 2-7. Stills from videotape of <i>Bandoneon !</i> performance October 13 1966, in the series 9 Evenings: Theatre and Engineering, 69th Regiment Armory, New York City.	85
Figure 2-8. Stills from videotape of <i>Bandoneon !</i> performance October 13 1966, in the series 9 Evenings: Theatre and Engineering, 69th Regiment Armory, New York City.	86
Figure 2-9. David Tudor, "Bandoneon Factorial Generalized Diagram", a score diagram for performances October 13 and 18 1966, in the series 9 Evenings: Theatre and Engineering.	87
Figure 2-10. David Tudor, "Bandoneon Factorial Audio Processing and Routing" (Tudor 1966d), showing two variations on usage of loudspeaker-objects for performances in the series 9 Evenings: Theatre and Engineering.	88
Figure 2-11. Stills from videotape of <i>Bandoneon !</i> performance October 13 1966, in the series 9 Evenings: Theatre and Engineering, 69th Regiment Armory, New York City. David Tudor with bandoneon.	89
Figure 3-1. Block diagram for <i>Rainforest 1</i> (1968) showing use of eight-channel amplifier with outputs to eight transduced objects; pickups (phonograph cartridges) return the sounds of each resonating object to a conventional sound system of between four and eight channels.	99
Figure 3-2. List of performance options for <i>Rainforest</i>	100

Figure 3-3. A 1971 setup for <i>Rainforest 1</i> .	108
Figure 3-4. Eight channels of low-power amplification built into a briefcase, for performances of <i>Rainforest 1</i> with the Merce Cunningham Dance Company, circa 1968-1971.	116
Figure 3-5. Lists naming objects to be transduced, attached to the eight-channel "briefcase amplifier".	117
Figure 3-6. "Wooden box" included on list taped inside eight-channel briefcase amplifier.	118
Figure 3-7. "Metal box" included on list taped inside eight-channel briefcase amplifier.	119
Figure 3-8. Detail of phonograph cartridge mounted in metal box, showing extension of stiff wire from stylus hole to body of the box itself, to conduct vibrations to the cartridge's pickup element.	121
Figure 3-9. "Springs" object as installed as part of <i>Rainforest 4</i> at Fort Worth Art Museum, October 1975.	123
Figure 3-10. Setup for performance of <i>Rainforest 1</i> , 1971.	127
Figure 3-11. Nombrex Audio Generator 30 and Midland Model 23-165 Audio Generator, as seen in <i>Rainforest 1</i> setup in Figure 3-3.	129
Figure 3-12. Portion of first page of memo from Gordon Mumma to John Cage and David Tudor, regarding sound setup for the Cunningham Company.	130
Figure 3-13. External and internal views of pulse generator constructed by David Tudor and used in performances of <i>Rainforest 1</i> .	132
Figure 3-14. Circuit diagram for David Tudor pulse generator device as shown in Figure 3-13.	135
Figure 3-15. Three devices constructed by David Tudor based on commercially available amplifier circuit boards.	138
Figure 4-1. Block diagram of the Pepsi Pavilion sound system.	153
Figure 4-2. Control layout for one of eight sound modification channels on the Gordon Mumma-designed Pepsi Pavilion console, showing FM, AM and highpass filter sections.	154

Figure 4-3. Partial list of David Tudor's source tapes for <i>Rainforest 3</i> , derived from the Pepsi Pavilion collection.	164
Figure 4-4. Spectrogram of a five-second excerpt of "BR WAVES SLO" (brain wave sonification played back at half speed) showing three distinct tone regions.	166
Figure 4-5. Notes on <i>Rainforest 3</i> .	170
Figure 4-6. List of technical requirements for performance of <i>Rainforest 3</i> and John Cage's <i>Mureau</i> , drawn up by David Tudor for Performing Artservices.	172
Figure 4-7. Preliminary sketch for routing of signals returning from loudspeaker-objects' contact microphones..	174
Figure 4-8. Preliminary sketch indicating consideration of use of four cassette tape recorders for playback.	174
Figure 4-9. Five variations on routing diagrams for mixing and distribution of signals returning from <i>Rainforest</i> loudspeaker-objects, with apparent cable counts above each diagram.	175
Figure 4-10. David Tudor's "master" score diagram for <i>Rainforest 3</i> .	176
Figure 4-11. David Tudor's notes on "new" features of <i>Rainforest 3</i> .	177
Figure 4-12. David Tudor's original diagram of eight-channel speaker setup for performance of <i>Rainforest 3</i> , Berlin, July 11 1972.	178
Figure 4-13. Identification of source tapes in first half hour of David Tudor's premiere performance of <i>Rainforest 3</i> , with John Cage's <i>Mureau</i> , Bremen, May 5 1972.	180
Figure 5-1. New Music in New Hampshire course list.	189
Figure 5-2. <i>Rainforest 4</i> generalized score diagram .	202
Figure 5-3. A view of the <i>Rainforest</i> workshop room in the inn at Stafford's-in-the-Fields, showing David Tudor's assistant Ritty Burchfield, and <i>Rainforest 4</i> in development.	207
Figure 5-4. View from balcony of preparations for <i>Sliding Pitches in the Rainforest in the Field</i> , in the barn at Stafford's-in-the-Field on July 7, 1973.	217
Figure 5-5. View of preparations for <i>Sliding Pitches in the Rainforest in the Field</i> , in the barn at Stafford's-in-the-Field on July 7, 1973.	218

Figure 5-6. View of preparations for <i>Sliding Pitches in the Rainforest in the Field</i> , in the barn at Stafford's-in-the-Field on July 7, 1973.	219
Figure 5-7. View of preparations for <i>Sliding Pitches in the Rainforest in the Field</i> , in the barn at Stafford's-in-the-Field on July 7, 1973.	220
Figure 5-8. View of loudspeaker-objects prepared for <i>Sliding Pitches in the Rainforest in the Field</i> , in the barn at Stafford's-in-the-Field on July 7, 1973.	224
Figure 5-9. David Tudor's master list of technical details for realization of <i>Sliding Pitches in the Rainforest in the Field</i> , July 7 1973.	231
Figure 5-10. Top: David Tudor's original diagram and notes for Chocorua <i>Rainforest</i> loudspeaker-objects.	232
Figure 5-11. Three makes of audio transducer identified by abbreviations in Tudor's notes for Chocorua <i>Rainforest</i> objects.	233
Figure 5-12. Another view of preparations for <i>Sliding Pitches in the Rainforest in the Field</i> .	234
Figure 5-13. David Tudor's notes on source material for copper still and plastic sprinkler loudspeaker objects for <i>Sliding Pitches in the Rainforest in the Field</i> .	235
Figure 5-14. Copy of Ann Sandifur's petition regarding the lack of women faculty at Chocorua '73, signed by most students and staff members of New Music New Hampshire, as printed alongside her review of the workshop series.	251
Figure 6-1. <i>Rainforest</i> installation at Buffalo State College, Buffalo NY, June 12 1974.	267
Figure 6-2. Walker Art Centre <i>Rainforest 4</i> installation, June 1976	277
Figure 6-3. Walker Art Centre <i>Rainforest 4</i> installation, June 1976.	278
Figure 6-4. Photograph of David Tudor and John Driscoll at the Walker Art Centre installation of <i>Rainforest 4</i> , June 1976.	279
Figure 6-5. Detail from Festival d'Automne programme book for series presented by David Tudor and Composers Inside Electronics, Paris 1976.	284
Figure 6-6. Detail from page one of John Driscoll's score realisation for CIE's performance of John Cage's <i>Cartridge Music</i> at the Festival d'Automne, Paris 1976.	295
Figure 6-7. One of Paul DeMarinis' 4x7 inch <i>Pygmy Gamelan</i> circuits.	302

Figure 6-8. Score diagram by John Driscoll for his <i>Listening Out Loud</i> , in a version similar to that presented at the Festival d'Automne 1976.	309
Figure 6-9. One of three pages of notes by Phil Edelstein listing preferred loudspeaker-objects for the Festival d'Automne 1976, as selected by Bill Viola, Paul DeMarinis, Martin Kalve and David Tudor.	315
Figure 6-10. <i>Rainforest 4</i> as installed at l'Éspace Pierre Cardin, Paris, November 2-6 1976.	319
Figure 6-11. <i>Rainforest 4</i> as installed at l'Éspace Pierre Cardin, Paris, November 2-6 1976.	320
Figure 6-12. <i>Rainforest 4</i> generalized score diagram.	323
Figure 6-13. John Driscoll's table for performance of <i>Rainforest 4</i> at Mills College, April 9 1975.	325
Figure 6-14. David Tudor's (foreground) and John Driscoll's tables for performance of <i>Rainforest 4</i> at the Institute of Contemporary Art, Philadelphia PA, April 1979.	325
Figure 6-15. Partial list of John Driscoll's prerecorded materials for performance of <i>Rainforest 4</i> .	327
Figure 6-16. Four incarnations of John Driscoll's toilet float sculpture.	333
Figure 6-17. Bill Viola in performance of <i>Rainforest 4</i> , Institute of Contemporary Art, Philadelphia PA, April 1979.	334
Figure 6-18. Linda Fisher listening to the oil drum at Lincoln Center, July 1998.	342
Figure 6-19. David Tudor's "first sketch" for rotating, highly directional loudspeaker research funding application submitted to the National Endowment for the Arts.	347
Figure 6-20. Diagram by David Tudor for performance of <i>Forest Speech</i> , March 20 1977, accompanying a Merce Cunningham Dance Company <i>Event</i> at Barnard College, New York City.	355
Figure 6-21. Composers Inside Electronics performing John Driscoll's <i>Ebers and Mole</i> at The Kitchen, New York City, September 23 1978.	356
Figure 6-22. Score diagram for <i>Forest Speech</i> .	356

Figure 6-23. John Driscoll with performance setup for <i>Ebers and Mole</i> , ca. 1978.	359
Figure 6-24. John Driscoll score diagram for <i>Ebers and Mole</i> as performed at The Kitchen, September 20 1978.	360
Figure 6-25. Martin Kalve, score diagram for <i>Earthing</i>	362
Figure 6-26. Illustration by Ralph Jones of a typical "star network" linking multiple electronic components at a central node.	364
Figure 6-27. John Driscoll, Ralph Jones, Martin Kalve, Marsha Heather Harris, two unidentified individuals, and David Tudor in Stockholm Airport, Jan, 1980 on the way to Berlin.	373
Figure 6-28. Composers Inside Electronics in Berlin, 1980.	373
Figure 6-29. Composers Inside Electronics in Berlin, 1980.	374
Figure 6-30. Composers Inside Electronics and <i>Rainforest 4</i> in Berlin, 1980.	375
Figure 6-31. Composers Inside Electronics and <i>Rainforest 4</i> in Berlin, 1980.	376
Figure 6-32. <i>Papermusic</i> instrument with embedded transducer and piezo pickup, by Cynthia Black and Phil Edelstein.	382
Figure 7-1. Bill Viola and Linda Fisher preparing for the <i>Rainforest</i> performance at David Tudor's memorial celebration, September 17 1996, Judson Memorial Church, New York City.	390
Figure 7-2. Preparing for performance of <i>Rainforest 4</i> at David Tudor's memorial celebration, September 17 1996, Judson Memorial Church New York City.	391
Figure 7-3. Two listeners hidden by resonating vintage hard disk, during preparations for performance of <i>Rainforest</i> at David Tudor's memorial celebration, September 17 1996, Judson Memorial Church New York City.	392
Figure 7-4. Views of installation process for <i>Rainforest 4</i> at the Clark Studio Theatre, Lincoln Center, New York City, July 1998.	407
Figure 7-5. Views of installation of <i>Rainforest 4</i> at the Clark Studio Theatre, Lincoln Center, New York City, July 1998.	408
Figure 7-6. Views of installation of <i>Rainforest 4</i> at the Clark Studio Theatre, Lincoln Center, New York City, July 1998.	409

Figure 7-7. Panoramic view of installation of <i>Rainforest 4</i> at the Clark Studio Theatre, Lincoln Center, New York City, July 1998.	410
Figure 7-8. View of installation of <i>Rainforest 4</i> at California Institute of the Arts, May 17 2001.	422
Figure 7-9. Views of installation of <i>Rainforest 4</i> at California Institute of the Arts, May 17 2001.	423
Figure 7-10. View of installation of <i>Rainforest 4</i> at California Institute of the Arts, May 17 2001.	424
Figure 7-11. Diagram by Phil Edelstein of possible Composers Inside Electronics webspace.	435

LIST OF TRACKS ON ACCOMPANYING AUDIO CD

Note: all tracks are excerpts from longer recordings.

Track 2 is excerpted with permission of the Cunningham Dance Foundation, from the soundtrack of the film *RainForest* (*Rainforest* 1968). Tracks 1, 3, 4, 5, 6, 7 and 11 are excerpted with permission of the Estate of David Tudor, from David Tudor's original library of recordings (tracks 2, 3, 4, 5 and 6 also with the permission of Gordon Mumma). Track 8 is excerpted with permission of New World Records. Tracks 9, 10, 12, 13, 14 are excerpted with permission of Composers Inside Electronics. Tracks 15 and 17 are excerpted with the permission of John Driscoll. Track 16 is excerpted with permission of Linda Fisher. Track 18 is excerpted with permission of Phil Edelstein. Track 19 is excerpted with permission of Bill Viola. Track 20 is excerpted with permission of Martin Kalve. Track 21 is excerpted with permission of Ralph Jones.

All rights remain with the composers and performers of the works represented on the CD.

1. *Bandoneon !* (David Tudor) 1:07
October 14 1966, 9 Evenings of Theatre and Engineering, New York City.
Monophonic recording (extremely distorted) by Ritty Burchfield.
2. *Rainforest 1* (David Tudor) 2:53
Premiere performance by David Tudor and Gordon Mumma, with Merce Cunningham's dance *RainForest*, March 9 1968, State University of New York, Buffalo NY.
3. *Rainforest 1* (David Tudor) 2:21
Excerpt from undated recording ca. 1968-70 of performance with dance *RainForest* (reel-to-reel tape in "Hi Fi" box). Performer information not given, but probably David Tudor and Gordon Mumma.
4. *Rainforest 1* (David Tudor) 2:24
Excerpt from undated recording ca. 1968-70 of performance with dance *RainForest* (reel-to-reel tape in "Red Seal" brand box). Performer information not given, but probably David Tudor and Gordon Mumma.
5. *Rainforest 1* (David Tudor) 2:34
Concert performance by David Tudor and Gordon Mumma, December 12 1970, Cornell University.
6. *Rainforest 1* (David Tudor) 2:27
Performance by David Tudor and Gordon Mumma with dance *RainForest*, February 8 1972, Brooklyn Academy of Music.
7. David Tudor: Pepsi Pavilion source tapes (eight examples, approximately ten seconds each, separated by silences) 1:36
 - a. "brain waves"
 - b. "BR WAVES SLO"
 - c. "brainwaves"
 - d. "cat's eye slow"
 - e. "beetle walking"
 - f. "mod n. jar slow" (modified nightjar)
 - g. "mos. t.t. normal" (mosquito in test tube)
 - h. "monkey slow"
8. *Rainforest 3* (David Tudor) 2:25
Premiere performance, with John Cage simultaneous performance of *Mureau*, May 5 1972, Radio Bremen. From CD *Rainforest II / Mureau* (New World Records 80540-2).
9. *Rainforest 4* (David Tudor / Composers Inside Electronics) 2:02
March 8 1974, Everson Museum, Syracuse NY, performed by Composers Inside Electronics (David Tudor, Linda Fisher, John Driscoll, Bill Viola). First public performance of *Rainforest 4*.

10. *Rainforest 4* (David Tudor / Composers Inside Electronics) 2:32
Studio recording November 20 1976, New York City, for *Dance In America* videotape by Merce Cunningham Dance Company, performed by Composers Inside Electronics (David Tudor, Linda Fisher, Martin Kalve, Bill Viola).
11. *Forest Speech* (David Tudor) 2:19
Undated recording ca. 1976-78; performers not listed.
12. *Rainforest 4* (David Tudor / Composers Inside Electronics) 3:09
Binaural recording January 1980, Moderna Museet, Stockholm, Sweden, recorded by John Driscoll and performed by Composers Inside Electronics (David Tudor, John Driscoll, Phil Edelstein, Martin Kalve, Ralph Jones).
13. *Rainforest 4* (David Tudor / Composers Inside Electronics) 2:08
Binaural recording January 1980, Akademie der Künste, Berlin, Germany, recorded by John Driscoll and performed by Composers Inside Electronics (David Tudor, John Driscoll, Phil Edelstein, Martin Kalve, Ralph Jones, Bill Viola). From LP *Rainforest IV* (Editions Block / Gramavision GR-EB1).
14. *Rainforest 4* (David Tudor / Composers Inside Electronics) 2:42
July 1998, Lincoln Center, New York City, recorded by Bob Bielecki and performed by Composers Inside Electronics (John D.S. Adams, Paul DeMarinis, John Driscoll, D'Arcy Philip Gray, Linda Fisher, Ralph Jones, Ron Kuivila, Ben Manley, Matt Rogalsky).
15. Twelve excerpts from John Driscoll's source materials for *Rainforest 4*, approximately ten seconds each, separated by silences. (John Driscoll) 2:48
 - a. L: pulse oscillator, no processing
R: pulse oscillator, transduced through bamboo rod
 - b. L: motor with speed control (recorded via contact mic)
R: chirping oscillator
 - c. L: mockingbird, processed
R: mockingbird, processed (rec. in Washington DC)
 - d. L: blowtorch
R: motor of heating system, recorded by contact mic on radiator
 - e. L: waterfall, rec. through wagon wheel rim
R: paddleball court, Salt Lake City
 - f. L: typewriter + oscillator loops
R: motor + arcade tank game
 - g. L: oscillator chirps
R: arcade tank game + organ pipe drones
 - h. L: *Earthing* source material + pulse generator + organ pipe drones + ultrasonics
R: ultrasonics
 - i. L: rain in alleyway, Rome
R: rain on metal sheet, rec. with contact mic
 - j. L: mockingbird
R: oscillator loops
 - k. L: rain
R: rain
 - l. L: oscillator modulated by birdsong
R: spring peepers
16. *Solo Synthesizer Music* (Linda Fisher) 2:17
January 6 1977, The Kitchen, New York City.
Performed by Linda Fisher and Martin Kalve.

17. *Listening Out Loud* (John Driscoll) 2:18
 January 7 1977, The Kitchen, New York City.
 Performed by John Driscoll, Phil Edelstein and Bill Viola.
18. *Shrieks and Nuptials* (Phil Edelstein) 2:14
 January 8 1977, The Kitchen, New York City.
 Performed by Phil Edelstein and Marsha Heather Harris.
19. *Gong* (Bill Viola) (two excerpts separated by silence) 3:48
 January 8 1977, The Kitchen, New York City.
 Performed by Bill Viola and Linda Fisher.
20. *Earthing* (Martin Kalve) 2:16
 September 22 1978, The Kitchen, New York City.
 Performed by Martin Kalve, David Tudor, John Driscoll, Ralph Jones, and
 Takehisa Kosugi.
21. *Star Networks at the Singing Point* (Ralph Jones) 2:05
 September 21 1978, The Kitchen, New York City.
 Performed by Ralph Jones, Martin Kalve, David Tudor, and John Driscoll.
22. Impulse responses for small loudspeaker-objects, four examples separated by
 silences (Matt Rogalsky) 0:11
 - a. metal soap dish
 - b. styrofoam slab
 - c. tin can
 - d. wooden box
23. Source materials for convolution with impulse responses, four examples separated
 by silences (Matt Rogalsky) 0:47
 - a. electronic feedback loops
 - b. toy car noises
 - c. voice materials from radio broadcast
 - d. skipping CD player
24. "Virtual *Rainforest*" binaural mix (Matt Rogalsky) 2:15
 Demonstrating four "virtual *Rainforest* loudspeakers", made by convolving
 impulse responses in example 22 with source sounds as in example 23, and
 then processing with head-related transfer functions. Objects are introduced
 sequentially, in stationary positions around the head of the listener (headphones
 required).

ACKNOWLEDGEMENTS

My deepest thanks to David Tudor's sister Joy Nemiroff, and the David Tudor Estate, for significant funding of my research. It would not have been possible otherwise. Other funding was gratefully received from the Social Sciences and Humanities Research Council of Canada (Doctoral Fellowship 2000-2003), the UK Overseas Research Students Award Scheme (Overseas Research Scholarship 2000-2003), and the Getty Research Institute (Library Research Grant 2001). Dr. Simon Emmerson has been my guide throughout this project and I have greatly appreciated his assistance and patience!

I would not have been able to begin or end this thesis without the support of so many friends and colleagues of David Tudor, particularly Jean Rigg and David Vaughan of the Cunningham Dance Foundation, and those of the original clan of Composers Inside Electronics who offered me interviews, access to personal archives, and much, much more: Paul DeMarinis, John Driscoll, Phil Edelstein, Linda Fisher, Russell Frehling, Ralph Jones, Martin Kalve, and Bill Viola. Ron Kuivila is also among the CIE clan and to him I owe my original introduction to David Tudor in 1994 and continued support and illumination since then in pursuit of a better understanding of Tudor's work. I have also greatly valued the input of the "younger set" of CIE musicians: John D.S. Adams, D'Arcy Philip Gray, and Ben Manley.

Others who must be warmly thanked for their assistance, in ways too numerous to elaborate completely but including interviews, co-performances, hints, suggestions, willing responses to email pestering, and offering of fruitful diversions include Maryanne Amacher, Larry Austin, Adam and Carolyn Barker-Mill, Amy Beal, Peter Behrendsen, David Behrman, Patricia Bentson, Michael von Biel, René Block, David Borden, Carolyn Brown, Ritty Burchfield, Jeannette Casey, Joel Chadabe, cris cheek, Nicolas Collins, Lowell Cross, Merce Cunningham, Guy De Bievre, Stuart Dempster, Bruce Duffie, Beverly Emmons,

Anthony Gnazzo, The Grimwits, Gisela Gronemeyer, Thom Holmes, Teddy Hultberg, Warner Jepson, Mimi Johnson, Tom Johnson, Alden Jenks, Douglas Kahn, Gregory Kramer, Laura Kuhn and the John Cage Trust, Takehisa Kosugi, Petr Kotik, Billy Klüver, Rolf Langebartels, Julie Martin, David Maswick, Tabitha Minns, Jacqueline Matisse Monnier, Gordon Mumma, Phill Niblock, Laurie North, Reinhard Oelschlägel, Pauline Oliveros, Jonathan Pease, Nancy Perloff, Peter Poole, Mary Caroline Richards, Stan Ries, Dan St. Clair, Stefan Stähle, Volker Straebel, Stacy Sumpman, Richard Teitelbaum, Stephen Vitiello, Greg Wagstaff, Simon Waters, Christian Wolff, Raph Worrick and Peter Zaporinuk.

Finally I would like to thank my partner Laura Cameron and son Arden Cameron Rogalsky for their support given in so many ways. I am blessed to have you in my life.

DECLARATION RE COPYING

Permission is granted to the University Librarian to allow this thesis to be copied in whole or in part, at his or her discretion, without further reference to the author. This permission covers only single copies made for study purposes, subject to normal conditions of acknowledgement.

The CD of audio examples accompanying this thesis may be auditioned for study purposed but may not be copied.

ABSTRACT

David Tudor's sound work *Rainforest* was created in four distinct versions between 1968 and 1973. The work's central concept is the use of various resonant objects as loudspeakers, or "acoustic filters", to modify sounds from numerous sources which are played through the objects. The author traces Tudor's exploration of the "loudspeaker-object" idea, which Tudor dates back to 1965, and considers the significance of the community of artists, engineers, composers and choreographers surrounding Tudor, for the development of each version of *Rainforest*. In particular this thesis is concerned with Composers Inside Electronics (CIE), the "family" of younger composer-performers which developed *Rainforest 4* with Tudor in 1973, and regularly presented it with him until 1982 as a large-scale "performed installation". During that time CIE also functioned as a collaborative ensemble performing other works by Tudor and the group's members, employing new technologies with an emphasis on "hand-built" electronic devices. A number of CIE works can be shown to be related to the *Rainforest* series. Following a hiatus between 1982 and Tudor's death in 1996, CIE has again performed *Rainforest 4* in several major installations, and has made efforts to bring a new generation of performers into the group. The author considers the dynamics of this process in the continuation of *Rainforest 4* up to 2006, and examines the group's discussions concerning possible future directions for *Rainforest*.

INTRODUCTION

Well I'd like to see the whole social situation change in regard to electronic music. [...] *Rainforest* occurred to me, the whole principle occurred to me when I was trying to reverse the current thinking about beginning and end, in an electronic chain. And it occurred to me that what I wanted was a whole forest—that's why I called it *Rainforest*—was a whole forest of individual voices. And then it became clear to me that I had to start at the speaker end.

David Tudor
(WBFO 1978)

David Tudor's place in the history of 20th-century music is well-known, but as yet hardly well-understood. This particularly applies to the work he accomplished in his "second career" as a composer-performer of electronic music, following on his first as an interpreter (at, around, and inside the piano) of musical scores produced by others. Tudor's electronic music practice, which developed throughout the 1960s and was well-defined by the early 1970s, was of a character which often made it extremely difficult to penetrate: "there's a large group of pieces", he once said,

which I've never taught to anyone and consequently I'm the only one who can do it. [laughs] [...] there are secrets in the sense that a work that develops, you know, and continues to develop, you never quite know to say when it's finished. And sometimes, when I work on an electronic principle that's still revealing itself to me, I don't like to, ah, to give it out (Tudor 1986).

Tudor, in the 1960s and 1970s, did not often work with the commercially produced tools of electronic music—the analog synthesizer, for instance, which came into its own alongside Tudor's drift into electronic music. "I don't use any standard instruments", he stated (Tudor 1986). He preferred, rather, to create his own "modular synthesizers" out of varied components, many homebuilt or otherwise custom-made, patched together in ways forming synergetic systems which to a large extent defied outside analysis. Not that such analysis was attempted or was even particularly possible; configurations of devices, embodying compositions, were generally unavailable for study, and in any case were perpetually being modified from performance to performance. No scores were on offer: "It all exists in my own notes. [...] But the detail isn't really there", he said (Tudor 1986).

One could say, however, that the general rule of "secrecy" by which Tudor seems to have composed and performed is proven by an exception: *Rainforest*, a piece exhibiting an uncharacteristic obviousness in its technical means and openness in its musical realisation, which from its earliest inklings to its most recent innovations spans the years 1965 to

the present. This is partly thanks to the fact that Tudor eventually inducted a large group of fellow composer-performers into performance of the piece and, in his words, "gave the piece away" (Tudor 1984). The core years of the piece's development are much more defined, however: the first composition which Tudor entitled *Rainforest* was commissioned in 1968, and the "giving away" of the piece took place in 1973. During this period the piece, which essentially depends on a single, easily explained principle, was realised by Tudor in a number of distinct ways, in which he was assisted and enabled by a large community of musicians, engineers and artists. The development of the piece between 1965 and 1973 was, I argue, driven as much by circumstance and community as it was by David Tudor's own innate curiosity and imagination.

It is the "evolution" of the idea of *Rainforest* with which I am concerned in this thesis: its four "versions" which Tudor eventually identified by number, but also its roots in Tudor's performance of the music of John Cage and others, its prehistory in the years 1965-1967, postscript in the form of a related piece, *Forest Speech* (1976-1978), and its continuation up to the present day, which finds all of David Tudor's younger colleagues—the Composers Inside Electronics (CIE) group—alive and well, still performing *Rainforest 4* from time to time, and actively planning its future. In this thesis I spend considerable time examining the work and function of Composers Inside Electronics, which extended from its origins as a *Rainforest* performance group: Tudor's influence, and resonances of *Rainforest*, may be traced through numerous works created by CIE members between 1973 and 1982. Composers Inside Electronics existed as a cooperative association of artist-composer-performers working with new technologies, which might be compared to other contemporaneous collaborative ensembles such as Sonic Arts Union (1966-1977: Gordon Mumma, Robert Ashley, Alvin Lucier and David Behrman), Musica Elettronica Viva (1966-present: Richard Teitelbaum, Alvin Curran and Frederic Rzewski), or The League of Automatic Music Composers (1977-1983: Jim Horton, Tim Perkis, and John Bischoff). CIE was unique, however, in its formation as a large group of "students" surrounding a

central "teacher"—David Tudor—whose work formed a basis for their community but also provided a platform for exploration and development of individual and shared interests.

David Tudor: background

As an introduction to David Tudor, a brief biographical sketch may be of use. Tudor was born in Philadelphia, Pennsylvania, on January 20 1926, and died on August 13 1996 in Tomkins Cove, New York. He studied piano from the age of six, and organ from the age of eleven. In 1942 Tudor joined the American Guild of Organists as an associate, and the following year was appointed organist at Trinity Church in Swarthmore, PA; between 1945 and 1947, Tudor was also organist at Swarthmore College. At Swarthmore, Tudor heard a performance by pianist Irma Wolpe, wife of composer Stefan Wolpe, and began piano studies with her, exhibiting an "overriding interest in contemporary music" (Holzaepfel 1994, 6). Tudor played the music of Stefan Wolpe, also studied composition and analysis with him, and in 1947 moved to New York City where he worked as an accompanist for musicians and dancers. In New York Tudor also continued his association with Stefan Wolpe, acting as pianist for his composition classes (with Morton Feldman among Wolpe's students). In late 1949, through Tudor's work as accompanist for choreographer Jean Erdman, he was introduced to John Cage, who was some 14 years older (Holzaepfel 1994, 32). Via Cage, Tudor was introduced to Pierre Boulez' *Second Sonata*, and during its realisation investigated the writings of Antonin Artaud which had informed Boulez' composition. This research "changed completely" Tudor's musical consciousness: "All of a sudden I saw that there was a different way of looking at musical continuity, having to do with what Artaud called the affective athleticism. [...] I had to put my mind in a state of non-continuity—not remembering—so that each moment is alive" (Holzaepfel 1994, 33). Shortly after Tudor's North American premiere of Boulez' *Second Sonata* in December 1950, he became integral to the developing

work of Cage, Feldman, Christian Wolff, and Earle Brown: in John Holzaepfel's description, the radical directions in which these composers took their musics were "responses to the challenge posed by another facet of Tudor's virtuosity, the virtuosity of mind" (Holzaepfel 1994, 45).

Much of the work of these composers, later collectively dubbed the "New York School", was concerned with indeterminacy and chance, and frequently employed new graphic notations and written instructions which required the active participation of the performer—often specifically Tudor—in their completion. The dedicated lengths to which Tudor went to make his performance versions of these works has been well-documented (Holzaepfel 1994, Pritchett 1993, Pritchett 1994). From 1951 to 1953, Tudor spent time at Black Mountain College in North Carolina as an instructor and pianist-in-residence, and took part in the well-known 1952 proto-happening organized by John Cage, including also Robert Rauschenberg, MC Richards, Merce Cunningham and Charles Olson, in which dance, music, and poetry were combined by chance means within a 45-minute time period (Revill 1992, 161). Tudor was at Black Mountain when Merce Cunningham formed his dance company in 1953, and he remained a musician of the company throughout the next forty-three years.

Over the 1950s, Tudor became acquainted with techniques of amplifying the acoustic piano, and by 1960 was performing works for other amplified objects, the best example of which might be John Cage's *Cartridge Music* (1960). Over the 1960s, Tudor gradually removed himself from the role of pianist, and assumed the role of composer, gravitating towards the performance of new sounds either by means of amplifying small acoustic sources, or by direct generation of electronic signals. The former technique describes the soundmaking means behind Tudor's first self-identified composition, *Fluorescent Sound* (1964). The latter technique describes Tudor's second, *Bandoneon !* (1966), a seminal "interactive" multi-media performance piece created with the collaboration of Bell Laboratories engineers.

Bandoneon ! included Tudor's first "loudspeaker-object" constructions, an idea which was to be further developed for the first version of *Rainforest*, commissioned for Merce Cunningham's 1968 dance *RainForest*. Three subsequent versions of *Rainforest* were devised (or identified in retrospect; the numbering of the versions was not finalized until around 1980), and each of these is identified and explored in this thesis. Along the trajectory of *Rainforest* were other large projects which informed its development, notably the Pepsi Pavilion for the 1970 Osaka World's Fair, on which Tudor acted as consultant; some of these projects are also explored in this document.

Tudor's focused work on *Rainforest* proper—that is, the time window within which the four numbered versions appeared—took place over a five-year period, from 1968 to 1973. As will be shown however, his work on the concepts behind the piece began in 1965 and did not cease until at least 1978, when Composers Inside Electronics performed a new group version of his *Forest Speech*, and then *Rainforest 4* continued to be performed by Tudor and CIE for another four years, until 1982.

Rainforest thus has a broad timespan unlike any other of Tudor's works, and due to his large number of younger colleagues, *Rainforest 4* remains a lively concern to this day, despite the fact it went through a hiatus between the years 1982 and 1996: my thesis concludes with consideration of the ongoing discussion within CIE in 2006 as to *Rainforest's* future, and the future of the group itself. It seems clear that *Rainforest* had a place of prominence in Tudor's professional and personal life, and a durability, which exceeded that of any of his other works developed alongside or "after" it.

A word on my numbering of the different versions of *Rainforest*: version numbers were not applied to the piece until 1981, when an LP recording of the large-group version of the piece was issued and it was given the title "*Rainforest IV*". The use of the Roman numeral "IV" as part of the title has since been usual practice. In this thesis, however, I have chosen for

clarity's sake to use Arabic numerals to number the four versions (there is precedent in Tudor's own notes for this). A Roman numeral may occasionally appear in the context of a quotation or citation, however. When "*Rainforest*" appears without an identifying version number, it usually refers to the broader project of the piece, considering all versions together as part of a larger conceptual whole.

The numbering of *Rainforest* versions is, as Gordon Mumma has reinforced on more than one occasion, somewhat artificial and even misleading, in the sense that Tudor was well-known for continuous development of his works from performance to performance, and did not necessarily proceed in the discrete, deliberate steps which might be implied by the existence of the titles *Rainforest 1, 2, 3 and 4*. Tudor clearly found it useful to mark waypoints in the life of the piece in this way, however, so I follow, while keeping in mind the dynamic nature of Tudor's practice and his manner of developing new extensions to his works through experimentation in performance.

Rainforest: concept and technology

In David Tudor's *Rainforest*, found objects are employed as "acoustic filters": sounds passed through an object, by means of a heavy transducer attached to it by a bolt or screw, are transformed according to the object's own unique resonant frequencies. These object resonances—the transformed sounds—are then usually amplified by use of contact microphones, and also heard through a conventional PA system.

"Transducer" is a generic term for any device which transforms one type of energy into another, but in the context of *Rainforest* (and throughout this thesis) it is commonly used to refer to the device which conveys sonic vibrations to a resonant object. This type of transducer may be thought of as a conventional loudspeaker coil, but lacking the conventional

loudspeaker's cone made of paper or plastic which allows it to move a large volume of air. Instead, by fixing the transducer to an object, the object itself acts as the cone of the loudspeaker. When not attached to an object, the "*Rainforest* transducer" produces little sound. As with a conventional loudspeaker, audio signals are brought to the transducer from an amplifier, and thus can be from any source.

To make object resonances more audible, especially when using small objects, contact microphones are attached to the object. Types of microphones used have included phonograph cartridges (employed as in Cage's *Cartridge Music*) and, in recent years as cartridges became difficult or expensive to acquire, piezoelectric elements.

Equalizers of various types are frequently employed in the signal chain, often as a means of better matching source sounds to object resonant frequencies, or to improve frequency response of the contact microphones.

The above description should give a good idea of the core technology of all versions of *Rainforest*. What differentiates the versions is primarily the type of source sounds used to activate the loudspeaker objects, and the size and character of the objects; these and other differences will be examined in the following chapters.

Prior *Rainforest* research

Since David Tudor's *Rainforest* (and particularly *Rainforest 4*) is one of his better-known works, developed over such a long time period during the second phase of Tudor's career, it is striking that a monograph has not yet been written focusing on the piece. Indeed, the topic has hardly even been broached in print, and in fact no significant monograph has yet been published on David Tudor, period.

John Holzaepfel's writings on David Tudor published to date are brilliant accounts of Tudor the musician and proto-composer, but do not cover the time period during which *Rainforest* was conceived and developed (Holzaepfel 1994, 2002). Brief descriptions of *Rainforest* appear in some well-known compact histories and surveys of electronic and experimental music and sound art (Chadabe 1997, 98-101, Holmes 2002, 230-231, Sutherland 1994, 238), but the piece is ignored in others (Nyman 1974/1999, Henri 1974, Furlong 1994). Where *Rainforest* is acknowledged in works of this type, it is, unfortunately, often with small distortions in the timeline of the piece, confusion in identification of its versions, and without adequate identification of the other significant individuals who worked alongside Tudor and assisted in bringing the different versions to life. This confusion has been continued with recent CD releases of *Rainforest*, which fail to provide correct identification of version numbers: the New World release of "*Rainforest II*" (New World Records 2000) is in fact a document of a performance of *Rainforest 3*; Mode Records' release *Rainforest* (Mode Records 1998) includes a recording of *Rainforest 4* which appears not only to be a pastiche of several undocumented performances—performers are not even properly credited—but also bears the misleading long title "*Sliding Pitches in the Rainforest in the Field*", which was only employed once, for *Rainforest 4*'s debut performance.

Writings by and about Merce Cunningham frequently mention Tudor, and the first version of *Rainforest* which was commissioned for Cunningham's 1968 dance *RainForest*, but as one might expect of dance-oriented writings, they do not provide great insight into the technology or performance of the dance's musical accompaniment; if it is described, it is usually in terms of its sonic affect in relation to the seemingly programmatic title of the dance (Klosty 1975, Cunningham 1991, Kostelanetz 1992). Writings about John Cage rarely mention *Rainforest*, even when the piece might most obviously be included: *Rainforest 3* was performed by Tudor, alongside Cage declaiming his text *Mureau*, on their final European tour together in 1972, but is not mentioned in major Cage

biographies (Revill 1992), or other significant collections of writings on Cage's work (Nicholls 2002).

Until 2004, the best available guide to the history and practice of *Rainforest* was probably the liner notes to the now-out-of-print 1981 LP of *Rainforest 4* (Gramavision/Editions Block 1981) which includes Tudor's score diagram for the technical setup of the piece, and brief but informative comments on its various earlier versions. Then in 2004, I co-published an article with long-time Tudor colleague John Driscoll outlining the history of the piece (Driscoll and Rogalsky 2004), which is a good basic guide but is still only a thumbnail account.

The present thesis is an effort to expand from that sketch into an exposition which not only tracks the idea of *Rainforest* through time, but also examines aspects of Tudor's social networks which helped make the piece what it has become, as well as looking at Tudor's influence in return on new generations of "live-electronic" composer-performers, particularly as embodied in his group, Composers Inside Electronics.

Research methodologies

David Tudor was well-known as a "reclusive and mysterious figure (albeit a perfectly friendly one)" (Holzaepfel 1994, 16); he did not write about his work, or discuss it often, even with friends, and interviews were infrequent. Piecing together this history of *Rainforest* has proven challenging, if not frequently frustrating; there are still significant parts of the story which I have not understood to my satisfaction (particularly those to do with *Rainforest 2*, which left little trace).

My research has incorporated much archival work, significantly with the David Tudor Papers, now held by the Getty Research Institute in Los Angeles. This collection was partly familiar to me before visiting the Getty, as I had assisted with removing much of it from Tudor's home in Stony

Point before his death; the experience of viewing these materials in the pristine surroundings of the Getty's reading room could not have been in greater contrast to the conditions under which I had initially seen them. There was some irony in examining these documents in a carefully controlled climate, under the scrutiny of security cameras, after having retrieved the same items, in the middle of a sweltering summer, from Tudor's attic, where they had been for perhaps decades.

Other collections held at the Getty were also useful to me, particularly the Experiments in Art and Technology papers and the Mary Caroline Richards papers, and I also made research trips to various John Cage archives (Northeastern University, Wesleyan University, the John Cage Trust) where I found many items of interest.

Of equal importance to these public archives were the private archives of Tudor's colleagues which yielded many documents and recordings I had not found elsewhere, broadening my knowledge of his music and milieu, and providing crucial detail. This was particularly so for the years of the 1970s when *Rainforest* expanded to include a large number of younger performers who also took on organisational roles, and thus kept copies of correspondence within the group, ephemera related to stagings of *Rainforest 4* and other works, and detailed notes on the production of the piece and logistics of its travel.

Beyond the acquisition of information through archival research, however, I felt from the beginning of the project that an original collection of oral histories would be critical to understanding *Rainforest*, the importance of Tudor's social network in its development, and the functioning of the younger group which grew around him in 1973, and continues its work with *Rainforest* to the present day. This was what the paper archives could only begin to hint at. Twenty-nine formal interviews were conducted, and many more informal discussions were had, concerning the evolution of the four apparent versions of *Rainforest*, practicalities of its performance, Tudor as a musician, teacher and mystic, and the

complex interactions within his Composers Inside Electronics group, which had developed a set of strategies, conventions, even "rituals", around performance of *Rainforest 4*. This was insight not to be gained from hours at the Getty Research Institute, nor from any other archive, and this thesis draws substantially from the interviews. Given the lack of sources documenting Tudor and his community, I felt it was a necessity to do so, but I also believed it was important to include the "voices" of members of this community, particularly those which made up Composers Inside Electronics (this extends to the inclusion of email correspondence which I received from numerous interviewees, which has a similarly conversational quality). To borrow the terminology of geographer Trevor Barnes, this is in aid of constructing a "lives lived" version of the history of *Rainforest*, in contrast to a "lives told" approach, the latter focusing on "a set of final accomplishments" with the former presenting a history as "a set of social and biographical processes" (Barnes 2001). Musicologist Vivian Perlis, writing about her research into the life and work of Charles Ives, notes that the oral history format "retained the complexities and even the contradictions" of her subject's personality, and aided in building a "multilayered portrait" (Perlis 1994). I have certainly found this to be true in the case of David Tudor, for the oral histories which I personally recorded. I have also drawn upon a number of published and unpublished interviews conducted with Tudor and his colleagues by others.

This "story-telling" aspect of oral history recording has often evoked the suspicion of professional historians, who may prefer to privilege written accounts such as "an authentic diary [...] a contemporary stock report, or [...] an eyewitness account transcribed on the day of the event" (Bornet, quoted in Grele 1998). Certainly, however much care one takes in formulating questions, the answers one receives cannot be assumed to be "the truth", even when they are given in good faith. Memory is fallible, and in the case of this research project, I requested my interview subjects to comment on professional and personal interactions with David Tudor which took place as many as 40 years prior. Some interviewees

conveyed their stories with certainty, and the ring of absolute truth. Many made best efforts to recall, with the proviso that it all happened a long time ago and the "facts" might be skewed. Occasionally I was simply unable to elicit responses to my questions, with the interviewee acknowledging, apparently in all honesty, that no memories were accessible on the topics I was pursuing. In at least one notable case, I obtained quite different accounts of the same event from the two people involved, and I was aware that events and their chronologies referred to in interviews needed to be cross-checked with other sources. As another geographer, Laura Cameron, reminds us, "Oral history does not recover the unsullied story of the past [...] one does not begin an oral history project unaware of unequal relations of power or with the idea that questions will go unchallenged". Researchers employing such methodology must be mindful "that the process of oral communication is not something that can be separated from nuggets of truth", as they "confront the dynamics of historical construction" (Cameron 1997, 18). Historian Ronald J. Grele notes that, due to the active participation of the historian-interviewer in the recording of an oral history, "the interview can only be described as a conversational narrative: conversational because of the relationship of interviewer and interviewee, and narrative because of the form of exposition—the telling of a tale" (Grele 1998). In this thesis I engage as a full partner in Cameron's "dynamics of historical construction".

Research by ethnomusicologists, of course, frequently relies upon the oral input of informants "chosen for musical and cultural competence rather than representativeness" (Myers 1992), without whose collaboration the researcher, even though he or she might be acting as participant-observer, would be at a disadvantage in coming to a fuller understanding of a musical culture. In the interviews which I conducted in the course of research for this thesis, and particularly those with members of Composers Inside Electronics, I have sought to obtain not only "facts of the matter"—specific recollections of David Tudor's working methods, approaches to performance, teaching techniques, lifestyle,

chronologies of events—but also much more fluid and explicitly subjective opinions and accounts of Tudor's interactions with others, which may have impacted on his activity as a musician and composer. As Grele (1998) notes, "the usefulness of any source depends upon the information one is looking for, or the questions one seeks to answer". This begs the question of what it means for a researcher to begin from the standpoint of measuring the "usefulness" of information, and certainly my own subjectivity in this matter means that what is contained in this thesis is necessarily a partial account of the history of *Rainforest*. There are perhaps many stories yet to be told, and "facts" to be revealed, about the work and about David Tudor: it is clear, for instance, that although my informants were carefully chosen, there are other major figures in Tudor's life and work who I did not have the opportunity to interview directly, and whose personal archives contain unknown documents or recordings which might have contributed to this project. In addition to the matter of who should or could have been included, the ways in which I have employed the oral histories I did record involve transcription and excerption, both of which involve a reshaping of the material. My source materials—original recordings, as well as transcripts—can be made available to other scholars however.

In addition to archival work and recording of oral histories, a third important facet of my research was personal involvement in the process of performing David Tudor's *Rainforest*. I came to Tudor's music as a composer-performer and have consistently maintained my own practice as a maker of "experimental" music; I felt that in order to fully appreciate Tudor's work on a personal level it was important to involve myself in its performance. I was fortunate to be invited to join with original members of Composers Inside Electronics in presentations of *Rainforest 4*, and other Tudor works, on several occasions after Tudor's death in 1996. Besides engaging in performances of *Rainforest 4*, I also took on as research projects the re-creation of earlier versions of *Rainforest*. Using Tudor's notes, diagrams, and recordings as guides, but not attempting to slavishly emulate Tudor's style, I made new public performances of *Rainforest 1*

and *Rainforest 3* on several occasions (the latter with Tudor's original source tapes, and in collaboration with a second performer delivering John Cage's text *Mureau*, as Tudor performed the piece with Cage in 1972). These experiences contributed to a much deeper appreciation of the materials of the piece and how they might be deployed in performance.

I was known to Composers Inside Electronics members as an academic and "Tudor scholar" as well as a musician and artist, and I positioned myself within the group as a participant-observer, much as an ethnomusicologist might when researching any musical microculture. At the same time that I was seriously engaged in understanding the performance of *Rainforest 4*, and attempting to make a real contribution to the piece and to CIE, I also felt able to stand back and observe the group dynamics at play, as well as other performers' approaches to the piece, its performance, and its history. The multiple experiences of performing with CIE, during which I gained practical knowledge of *Rainforest 4* and the workings of its community, informed the interviews I eventually conducted with CIE members.

On the subject of ethnomusicological fieldwork, Helen Myers writes that "However artful, the fieldworker can never blend without a trace into the local scene [...] However closely your appearance and behaviour match norms of the community, the social scientist is always an outsider", while at the same time "There is no substitute in ethnomusicological fieldwork for intimacy born of shared musical experiences. Learning to sing, dance, play in the field is good fun and good method" (Myers 1992). This clearly pertains to research of a musical culture other than one's own, while my research was conducted within a field which was already, to a large extent, my home territory. Myers' comments on "outsider" status were certainly reflected in my experience, however: my identification and background as a fellow composer-performer may have won me some respect from the community of musicians I sought to study, but my simultaneous identity as an academic may have laid me open to some

suspicion. A general attitude I sensed within Composers Inside Electronics—at least the core group which began working with Tudor in 1973, several of whom expressed this opinion directly—was that academic approaches to understanding David Tudor were of limited value. This came to the fore during the 2001 symposium on Tudor's life and work at the Getty Museum in Los Angeles: two days of paper sessions devoted to academic investigations and evaluations of Tudor's practice and personality, which were attended by a number of the CIE clan. I personally took part in these sessions, in a co-presentation with John Driscoll on the history of *Rainforest* which took a somewhat more casual and anecdotal approach than many of the other presenters. After the symposium, it was evident from conversations and email communications with CIE members who had attended, that some were dubious as to the value of academic debate over David Tudor, which was seemingly so removed from the practice of his work and knowledge of the "real" man himself.

I had some similar misgivings: as stated above, I felt that in order to become fully engaged in my research—and to become fully connected with members of CIE who might resist the "academic"—I should contribute to the group as a performer of *Rainforest 4* in addition to carrying out archival work and interviews. This development of a real and significant relationship with members of CIE brings up issues of trust and responsibility which both enable and complicate research. Genuine friendship with one's research subjects brings the result that the fruits of research are shaped to some extent by that friendship, and this thesis—especially the sections which pertain to CIE—has undoubtedly been shaped in this way. Each decision I made, as to which observed details or interview comments were pertinent to the thesis and ought to be included, was accompanied by some agonizing over how its inclusion would be received by the large number of Tudor's friends and colleagues who would be among my readership. Myers (1992) suggests that in representing fieldwork, "Conscience must guide the use of intimate facts", and I hope the readers of this thesis will agree that I have not exceeded

appropriate bounds, wherever they may be. Besides taking into account a responsibility to Tudor's friends and colleagues, however, I have also exercised what I felt was a responsibility not to write simply a celebration of Tudor, a hagiography. This perhaps contains the risk that I may alienate myself from the community which I strove to inhabit, and wish to remain personally and professionally connected with. I would return to the acknowledgement that this thesis is a partial account, and an attempt to thoughtfully provide one history of *Rainforest*, and its attendant community; there will undoubtedly be others.

Phil Edelstein, one of the Composers Inside Electronics, once made a note to himself that "writing about the work [*Rainforest*] feels like a one-dimensional flattening of a space [whose] beauty was found in folds of multiple dimensions" (Edelstein 2001). It is certainly difficult to evoke the "multiple dimensions" of *Rainforest* through a sustained text such as this but I hope some of that beauty is conveyed, along with technological and aesthetic detail and insight into its social dynamics, resulting in a better understanding of a work, and an accompanying composer-performer microculture, which may be David Tudor's most significant legacy.

Chapter 1
CONTEXTUALISING RAINFOREST

Contextualising *Rainforest*

The time period bracketed, approximately, by John Cage's *Cartridge Music* (1960) and David Tudor's *Forest Speech* (second version, 1978) saw a surge of interest by composers and artists in sound as a physical phenomenon. It is worthwhile considering Tudor's *Rainforest* series in the context of other work which similarly explored or exploited acoustic principles, some of which takes a reductionist, even pedagogical approach which could be categorised as minimal or conceptual art, and some which involves a less rigorous exposition of the physics of sound in favour of an aesthetic of improvisation or employment of chance methods. Tudor can be situated in a line of experimental instrument builders which includes Luigi Russolo and the Baschet brothers, but his focus in *Rainforest 1-4* on the use of objects as complex filters—which I perceive as Tudor's intention to work a kind of sonic alchemy—sets his project apart as historically unique. *Rainforest 1-3* were relatively small-scale works, so constructed in order to make it possible to pack them in a few cases for touring. They were performed by one or two people. *Rainforest 4* (1973) differs from earlier versions of Tudor's piece in that it takes the form of a sound installation typically realized by a group of between four and twelve musicians. Pigeonholing the piece is made complicated by the fact that it is actually a "performed installation" combining aspects of sound sculpture exhibition, live concert performance and audience interaction. The term "sound installation" is attributed to Max Neuhaus, who dates his own first work in this genre to 1967. The term "performed installation" I first heard used by Ron Kuivila to define a sound installation activated by real-time input from performers (personal communication, 1998).

This chapter contextualises Tudor's *Rainforest* project in the broader context of sonic arts between approximately 1960 and 1978, exploring the project's links to the work and ideas of other artists/musicians/composers. Tudor maintained personal connections with many of these people; a cross-fertilisation of ideas seems to have occurred. It is not my

intention to disentangle "who came first" in the rich network of individuals exploring similar themes: it might be said that each was working on the same problem from a different angle. What is interesting is the diversity of approaches, and the ways in which David Tudor's *Rainforest* works connect with these, and yet stand alone as a unique series. I will focus on artists with whom Tudor had personal associations, including Karlheinz Stockhausen, La Monte Young, John Cage, Alvin Lucier, Max Neuhaus, Pauline Oliveros, Michael von Biel, Phill Niblock, and Maryanne Amacher.

In this chapter I also contextualise *Rainforest* within Tudor's own life and practice by examining his self-professed relationship to "nature" and his involvement with the esoteric belief system of Rudolf Steiner. These did not necessarily inform the creation of *Rainforest* programmatically, but some light may be shed on the piece, and Tudor's practice as a whole, by their consideration.

Artists and acoustics

The large number of works explicitly concerned with acoustics between approximately 1960 and 1978, by an almost equally large number of composers and artists, can be roughly grouped into two categories: pieces concerned with sound's propagation through air, forming invisible architectures as it interacts with solid objects, and pieces which explore how sound travels through, and is transformed by, solids. An accompanying interest for some was the way in which sound interacts with the ear to produce psychoacoustic artifacts. We can look to the experience of sound recording and editing on tape, and the increasing availability of electronic music studios during the 1950s, as crucial to work between 1960 and 1978 which explicitly addresses resonance.

Experimentation with a sine-wave oscillator reveals acoustic detail of a space in a way which any other instrument does not. Experience of recording with a microphone reveals invisible detail of how sound

occupies a space, in a focused way which is different from unmediated listening. The physicality of recording tape itself must have been incredibly important; for the first time a composer could capture a sound wave in a medium which directly represented the flow of time. John Cage wrote in a 1957 talk, "Since so many inches of tape equal so many seconds of time, it has become more and more usual that notation is in space rather than in symbols of quarter, half, and sixteenth notes and so on" (Cage 1957), and his score for *Williams Mix* (1953) is a literal graphic representation of elaborate edits to be cut into quarter-inch reel-to-reel tape, where lengths of tape are lengths of time.

Lastly, the electromechanical reproducer of sound, the loudspeaker, reveals the mechanics of sound waves in a way which acoustic instruments do not. To see a loudspeaker reproducing a very low frequency sine wave is astonishing, and reveals in an instant what is invisibly going on around us when we experience changes in air pressure as sound.

Compositions for multiple loudspeaker playback began to be realised in the 1950s: Cage's *Williams Mix* presents eight independent channels performed on approximately synchronized monophonic reel-to-reel tape recorders arrayed around the audience; Le Corbusier's pavilion, created for Philips Radio Corporation at the 1958 World's Fair in Brussels, with substantial input from Iannis Xenakis, employed 350 loudspeakers controlled by a switching mechanism which sent Edgard Varèse's three-track *Poème Électronique* and Xenakis' own *Concrèt PH* on nine independent trajectories. With the focus on moving a sound's origin, and two of the three tracks devoted to enhancing the acoustic properties of the space through reverb and "stereophonic effects" (Meyer 2001, slide 55), the projection of the *Poème* was an exercise in moving sound in space, but not a study of how sound moves in space; not, at least, in the same manner as was the very focused work of others just a few years later.

Numerous experiments with diffusion of sound throughout the 1960s include several developments by people close to Tudor, some of which he took advantage of in his own work. One of these was the "proportional control system" designed by engineer Fred Waldhauer for use in the "9 Evenings of Theatre and Engineering" produced by Experiments in Art and Technology in New York City in 1966. This general-purpose system for using control voltages to control arbitrary functions found one application as a flashlight-controlled sound distributor for choreographer Deborah Hay's performance piece *Solo*, which Tudor performed using two flashlights over a 4x4 grid of photocells, moving sounds among sixteen loudspeakers. The sound material being distributed was a two-track recording of *Funakakushi* by Toshi Ichiyanagi; Tudor also found application of Waldhauer's proportional control system in his own piece for the 9 Evenings, *Bandoneon !*, using microphone signals from his bandoneon to move sounds among the venue's loudspeakers.

David Behrman, Tudor's colleague in the Cunningham Dance Company between 1968 and 1971, produced a similar effect with his inexpensive and low-tech "photocell mixer" which used four light-sensitive resistors in a passive circuit to control distribution of an input signal to four outputs, also by using a flashlight in a darkened room. The circuit functions equally well in reverse, mixing four inputs to a single output. One of these devices, which may have been built by Behrman, is included in the David Tudor instrument collection at Wesleyan University.

Lowell Cross, an important Tudor collaborator for more than ten years, beginning with *Bandoneon !* in 1966, presented Tudor with two models of his "sound stirrer", which like Behrman's photocell mixer distributed one input to four outputs, or vice versa, by means of a continuous rotary potentiometer with a crank-like handle (both of which are among Tudor's instruments at Wesleyan). It is worthwhile noting Tudor's commitment to spatialisation of sound by means of multiple loudspeakers: not only in his solo installation and performance work, but also as a musician of the Merce Cunningham Dance Company, which since the 1970s has toured

with a high-quality programmable diffusion system at the insistence of Tudor and the other company musicians.

Rainforest Prehistory

David Tudor's *Rainforest* did not grow without some compost; James Pritchett (2000) and John Holzaepfel (1994) have detailed his extensive work in the late 1950s and early 1960s with amplification of small sounds in realisations of pieces by John Cage; explorations of structure-borne sounds detected with contact microphones, exemplified by Tudor's 1959 realisations of *Solo for Piano* (1958), as well as *Cartridge Music* (1960) and *Variations II* (1961), preceded by experiments with piano amplification in works such as Bo Nilsson's *Night Wandering* (1958, performed with Merce Cunningham's dance of the same title). John Holzaepfel (1994, 312) identifies Tudor's realisation of *Solo for Piano* in 1959 as the "beginning of an evolution" from Tudor as pianist to Tudor as sound artist. Tudor also worked with amplification and processing of structure-borne sound at Mills College in 1967, in a realisation of Michael von Biel's *Book for 3*, which employed contact microphones attached to rotisserie barbeques.

Douglas Kahn has drawn attention to the burgeoning interest around this time for experimental musicians to experience sound from the "inside ... in the sense of one's envelopment within the sound and in the sense of the attention paid to 'microscopic' subtleties of the sounds that had hitherto gone unheard" (Kahn 1999, 230). Kahn makes this comment with regard to the music of La Monte Young, who from the late 1950s was creating compositions for acoustic instruments based on long sustained tones: Young's *Trio for Strings* (1958) opens with a single viola tone sustained for four and a half minutes, and incorporates other similarly long tones, as well as a substantial amount of silence—more than 13 minutes of the 58-minute piece (Gann 1996, 152). David Tudor met Young at Darmstadt in 1959 and soon was playing his compositions such

as *Study III* (1959) in New York and Europe (Potter 2000, 44). Young also encountered John Cage's work at Darmstadt and, while occupied with creating music that filled space with what Dave Smith called "sculptural qualities" (Potter 2000, 35), Young also made several works which, like *Cartridge Music* and Tudor's version of *Variations II*, explore the transmission of sound through structure, and the production of sound through friction. *Poem for Chairs, Tables, Benches, etc. (or other sound sources)*, composed in 1960, was scored for furniture being pushed or dragged across the floor, and was premiered in New York by Cage and Tudor before Young moved there from California (Potter 2000, 45). Another of Young's "frictional" sound works was the notorious *Two Sounds*, created by Young and Terry Riley, abrasively scraping a tin can against a glass window, and a drumstick against a gong. This was used as accompaniment first by choreographer Anna Halprin in Berkeley in 1959-60 (Young was musical co-director of her company), and then adopted by Cage, as musical director of "Merce Cunningham and Dancers", for Cunningham's *Winterbranch* (1964). Tudor, a good friend of Young's by this time, was responsible for introducing him to Yoko Ono, whose influential loft performance series Young went on to curate. In 1960, Young dedicated three piano pieces to Tudor, ranging from the comedic—*Piano Piece for David Tudor #1* calls for the pianist to feed the piano a bale of hay—to the conceptual: *Piano Piece for David Tudor #3* consists solely of the statement "most of them were very old grasshoppers" (Potter 2000, 51).

Composition 1960 #7, a perfect fifth sustained "for a long time", foreshadows the drones of the "Theatre of Eternal Music", Young's group from 1962 to 1966, whose sustained-sound performances were maintained at a high amplitude in order to emphasize sum and difference tones: as Henry Flynt (1996, 77) described it, "unvarying sound-saturation".

In the mid-1960s Young began to use electronic sources to create sustained-sound environments that could last for weeks or months. Young and his partner and collaborator Marian Zazeela (1996, 218-219) write that

[...] we maintained an environment of constant periodic sound waveforms almost continuously from September of 1966 through January of 1970 [...] we sang, worked and lived in this harmonically tuned acoustical environment and studied its effects on ourselves and the varied groups of people who were invited to spend time with the frequencies.

These were the *Drift Studies*, so called because the analog oscillators used tended to drift out of Young's idealized perfect-ratio tunings. One *Drift Study* recorded in 1969 consists of two oscillators tuned in the ratio 32:31. Young (2000) says of the *Studies* that "the drift of the phase relationships of the individual sine waves [...] created] audible shifts in the standing wave patterns [...] at very loud levels one began to feel that parts of the body were somehow locked in sync with the sine waves and were slowly drifting with them in space and time". Sum and difference tones were also enhanced by the amplitude. Douglas Kahn (1999, 232) reflects that the attention paid to sustained sounds by Young, Zazeela and the other Theatre of Eternal Music players, was a process of revealing that "a sound is *many* sounds".

Phill Niblock also began developing his own approach to high-intensity drone compositions around this time, beginning with a 1968 piece for organ performed at the Judson Church in New York City, with Meredith Monk sustaining clusters of pitches (Niblock 2000). Niblock came from a background as photographer and cinematographer, and his interest in sound appears to be related to a cameraman's interest in light: it envelopes, and reflects. Niblock's compositions, performed at high amplitude, like the Theatre of Eternal Music's improvisations, create acoustic and psychoacoustic effects through density and microtonal variation.

The experience of sound as "enveloping" requires that it be contained within an envelope; Young's and Niblock's musical experiments were as much explorations of the spaces they filled as they were explorations of combinations of sustained pitches. Tudor's conception of the *Rainforest* object is explicitly about revealing the "many sounds" within one: his loudspeaker-objects, first prototyped in *Bandoneon !* for the 9 Evenings of Theatre and Engineering in 1966, act as acoustic filters which naturally amplify some frequencies while dampening others. Tuning sounds to suit the objects is an exercise in finding concurrences between input sound and object, so that the "many sounds" can be revealed within the "envelope" of the object. Besides these loudspeaker objects, *Bandoneon !* employed a switchable bank of ordinary loudspeakers positioned around the performance space (the vast 16th St Armory in New York City) which turned the entire venue into a feedback instrument. Tudor recalled that "the sound in the Armory was extraordinary, so reverberant. Once you started something oscillating, it would go on forever" (Chadabe 1993).

Just prior to the development phase of *Bandoneon !*, an important experiment in revealing these "many sounds" was carried out by Karlheinz Stockhausen in his 1964 *Mikrophonie I*. Stockhausen and Tudor were close from the mid-1950s, when the former dedicated several of his *Klavierstücke* series to the latter. The last of these was *Klavierstücke XI*, demanding an interpreter "who is close to sound and silence, who is open enough—unpredictable and co-creative—in giving a work form, like the pianist David Tudor" (Stockhausen 1957). Stockhausen and Tudor's close relationship continued until at least 1964, when Tudor abandoned a USA concert tour with Stockhausen in order to perform Cage's *Atlas Eclipticalis* under Leonard Bernstein.

Mikrophonie I, for tam-tam and live electronics, is said to have originated as Stockhausen "leaned close to the surface of the vibrating tam-tam" hanging in his garden and "discovered strange sounds that could only be

heard really close up" (Nordin [undated]). The piece is scored for movement of two microphones over the surface of the tam-tam by two performers, detecting the sounds produced on the instrument by two players. Michael Kurtz (1992, 135) writes that "Just as a doctor uses a stethoscope to listen to a body, so the microphone was to make audible the 'inaudible vibrations' of the tam-tam". The sounds picked up by the microphones are then altered by two further musicians who employ bandpass filters and amplitude controls. It is in many ways an analog of *Cartridge Music*, which was written four years earlier, in its focus on revealing "hidden" worlds of sound, and in its division between sound makers and sound modifiers: Cage's score calls for tone and amplitude modification as well, with the implication that each phonograph cartridge used as a pickup can be played by two people, one to make sounds and the other to modify them ("Let the number of performers be at least that of the cartridges, and not more than twice the number of cartridges" (Cage 1960)). It is worth noting that the first performance of *Cartridge Music* was made by Cage, Tudor, and others at the atelier of Mary Bauermeister in Cologne on October 6 1960, with Stockhausen in attendance (Dörstel 1993, 43).

Tudor, seeming also to follow from the example of *Cartridge Music*, made an extraordinary effort in 1964 which he retrospectively identified as his first, ephemeral, composition: *Fluorescent Sound* was devised for the Moderna Museet, Stockholm, to accompany a "combine" performance, *Elgin Tie*, by Robert Rauschenberg. Rauschenberg invented the term "combine" in the early 1950s to describe his assemblages which crossed boundaries between painting and sculpture, but by the 1960s he also applied the term to performance pieces which might also be referred to as "happenings". Rauschenberg began using sound as an important performance element as early as 1952 with his collaborative participation as turntablist in the "*Black Mountain Piece*" organised by John Cage at Black Mountain College, in which Tudor also appeared as pianist (Sutherland 1994, 120); Rauschenberg's "white paintings" also formed part of the set. His "combines" of the early 1960s included instances of

wearable acoustic feedback devices, and installation works such as *Dry Cell* (1963) and *Oracle* (1965) were early examples of sophisticated "interactive" or "responsive" sound sculptures. Both these works were made in collaboration with Billy Klüver, who co-founded Experiments in Art and Technology (E.A.T.) with Rauschenberg. For E.A.T.'s 9 Evenings of Theatre and Engineering in 1966, Tudor subtitled his piece *Bandoneon !* "a combine", suggesting the extent to which he was influenced by Rauschenberg's ideas.

Tudor's *Fluorescent Sound* consisted of the lighting fixtures of the Museet transformed into a playable instrument: contact microphones were affixed to the "thousand fluorescent light bulbs" of the gallery, controlled by "75 switches with three light bulbs on each switch" (Tudor 1998a). Tudor devised a score (now lost) for playing the switches and made a solo performance playing the switches like a keyboard and amplifying the small sounds of the bulbs pinging on and off. The work is more stripped-down in concept than either *Cartridge Music* or *Mikrophonie I*, while it is both greater in scale and lesser in its means than either of those compositions. Tudor's preparation time was "nearly three days" (Tudor 1998a) and his instrument was distributed throughout a large area, yet it was under control of one player and its variation depended not on deliberate modification of sounds deliberately produced, but on causation of sounds which were indeterminate as to their exact qualities in pitch and time. It is perhaps more akin to *Cartridge Music* in its use of contact microphones to detect "unheard" structure-borne sounds, but *Mikrophonie I*, employing microphones held as close as possible to the tam-tam's surface, could also be said to explore similar terrain.

Fluorescent Sound and *Bandoneon !* will be examined in more depth in Chapter 2.

Returning to La Monte Young and others connected with the Theatre of Eternal Music, who were concerned with exploring the interaction of

sound with space in the first years of the 1960s, it should be noted that their interests were mirrored by artists working elsewhere. In San Francisco, in 1961, Pauline Oliveros composed her first work, *Time Perspectives*, for recorded sounds transformed without electronics, using "the natural acoustics of her bathroom and some cardboard tubes to filter and enhance the raw sounds" (Heidi von Gunden, quoted in Holmes 2002, 206). Oliveros says that this was done both out of necessity (since she lacked access to a studio with electronic processing equipment) and out of "core interest in the resonance of tubes for filtering sounds" (Oliveros 2003).

As early as 1958, Gordon Mumma was creating "cybersonic" circuits, which responded to room and instrument resonances (Holmes 2002, 228). As Mumma explained in an article by Slobin and Sheff (1966), "A cybersonic procedure uses aspects (parameters) of a sound to reshape its own characteristics or determine characteristics of following sounds". Mumma was part of the ONCE group in Ann Arbor, Michigan, which produced an influential series of experimental concerts from 1961-1965. Other individuals connected with ONCE were also exploring acoustic principles: Robert Ashley's *The Wolfman* (1964) was built on microphone/loudspeaker feedback modulated by "putting your mouth up against the microphone ... [creating] a model of the room in the size of the vocal cavity" (Ashley, quoted in Holmes 2002, 28). Ashley's score includes the performance note that "It is very important that the singer observe the need to produce all of the vocal sounds with the tongue touching at some point along the roof of the mouth. This particular kind of vocal cavity allows a certain amount of acoustical feedback to be present 'within' the sounds produced by the voice [...]" (Ashley 1964, 6). Tudor and Cage were frequent guests of the ONCE group beginning with a concert in the ONCE Festival's first season in 1961.

Focus on Place and Environment

After its final season of concerts in 1965, the ONCE group members continued to produce events in Ann Arbor including the first performance of Alvin Lucier's *Vespers* in 1967. *Vespers* is the earliest of many Lucier works which explicitly address the behaviour of sound in space: in this case Lucier's inspiration came from the sonolocation abilities of bats (the *Vespertiliade* family in particular), and in performance with devices which emit sharp clicks which echo off objects and surfaces, Lucier's goal was "to make the audience hear the acoustic characteristics of the performance space" (Lucier 1995, 64). Around the same time, Lucier made a piece which explored the modification of sounds through solids, recalling Cage's *Cartridge Music* and anticipating Lucier's own *The Queen of the South*. This was *Shelter* (also 1967), requiring the audience to be within "any dim or dark enclosable space... Close all openings to the shelter to block the entry of airborne sounds. Attach sensors to the inner surfaces of the shelter in order to pick up sounds that originate outside the shelter or within the structure of the shelter itself" (Lucier 1995, 302). The theatrics of the piece connect strongly with Cold War imagery, evoking a post-nuclear huddling of protected survivors isolated from an unknown and possibly dangerous outside world.

Less forbidding exterior locations were also to be explored for their sonic identities: from 1965, Max Neuhaus led a series of "soundwalks" (the term, now attributed to R. Murray Schafer, had yet to be invented) entitled *Listen: Field Trips Thru Found Sound Environments*. These were neo-scientific expeditions into the "field": the audience taken by bus to an unknown destination and allowed to explore with their ears (and other senses) an unfamiliar environment. There was no lesson intended to be learned or clearly defined aesthetic experience to be had, but Neuhaus seems to have conceived of this immersion in a sound field (evoking a school field trip) as an experience which might bring about a kind of sonic illumination: the encouragement of ear-based exploration might raise questions about the behaviour of sound in space, if not provide answers.

Framing an existing sound environment, in a manner similar to Cage's *4'33"*, has the potential to redefine all listening.

An interesting variant on soundscape listening was explored by Maryanne Amacher from 1967 onwards, in her *City Links* series. The *City Links* pieces use remote soundscapes as real-time sound materials for remixing, via high-quality telephone lines. For three years Amacher had in her studio a continuous feed from a microphone situated on the Boston harbour. For a shorter period during those three years she also had a second microphone on the waterfront at Battery Park in New York City, which eventually had to be removed during a city workers' strike because their union feared it was a bugging device. The first *City Links* performance was done on live radio, with eight remote audio feeds from industrial sites (Amacher 2000).

Neuhaus' and Amacher's East Coast focus on soundscapes was mirrored on the West Coast by the development of the World Soundscape Project at Simon Fraser University in Vancouver. Officially formed in 1971 by composer R. Murray Schafer as the extension of a sound-pollution course he taught in the Department of Communication in the late 1960s, the Soundscape Project involved a number of younger composers, notably Barry Truax and Hildegard Westerkamp, in comparative studies of local soundscapes in Canada and Europe (Truax 1978). Part of the consciousness-raising objective of the Project was to bring an awareness of acoustics and the behaviour of sound to the general public. This had the goal of equipping the average listener with tools for critiquing the soundscapes they live in, and the means of improving them (through reduction of everyday noise) by way of activism at the local, national and international level: "to find solutions for an ecologically balanced soundscape where the relationship between the human community and its sonic environment is in harmony" (Kallmann *et al.* 1992).

Truax and Westerkamp were strongly influenced as composers by their involvement with the World Soundscape Project and chose to work in the

studio with field recordings they themselves had collected, producing works for radio broadcast and acousmatic diffusion performance; the World Soundscape Project archives contain hundred of hours of these field recordings which continue to be a resource for "soundscape composers" in the acousmatic tradition. For instance, Darren Copeland's 2004 composition for tape, *On Schedule*, has as its main sonic resource a single train recording taken from the World Soundscape Collection at Simon Fraser University; in the 1980s, Copeland was a student of Barry Truax at Simon Fraser's Department of Communication (now School of Communication).

Feedback and Room Resonances

In the mid-1960s, Max Neuhaus began performing his realisations of Cage's *Fontana Mix*, an indeterminate score consisting of a number of transparent graphics to be overlaid and interpreted by the performer. In Neuhaus's version, *Fontana Mix-Feed*, sounds were generated by acoustic feedback, modulated by potentiometers built into a homemade circuit reminiscent of David Tudor's homebuilt boxes: one of Neuhaus' *Mix-Feed* devices is in fact among Tudor's collection of electronic instruments, now part of the World Instrument Collection at Wesleyan University. For a 1967 recording of the piece, Neuhaus' notes state:

In this performance, the adjustable resistors were controlling the frequency response of two channels of feedback which were set up by putting two microphones in the vicinity of their respective loudspeakers [...] The specific resistor to be changed was then decided by throwing dice. Throughout the piece, these changes in the adjustable resistors are extremely slow and gradual [...] The score removes my taste and musical judgment and allows the electronic and acoustic phenomena of that particular situation to produce the piece. (Neuhaus 1967)

Other versions of *Fontana Mix-Feed* employed tympani as resonators to produce changing feedback states. Neuhaus' use of acoustic feedback

was echoed in 1970 by David Tudor's work *Microphone*, which employed directional microphones facing an array of loudspeakers.

Several other works from this era which explore room resonances ought to be mentioned here: they are also connected to the "experimental music axis" which had at its heart John Cage, David Tudor and the Merce Cunningham Dance Company. David Behrman's *Wave Train* is composed for electromagnetic pickups placed on the undamped strings of a grand piano, and their amplification increased to the point of feedback, causing the strings of the piano to resonate sympathetically, with their resulting vibrations also amplified via the pickups. Multiple performers create controlled, overlapping waves of feedback (Behrman 1966). Gordon Mumma's "cybersonic" pieces already mentioned are exemplified by *Hornpipe* (1967) which employs homebuilt, wearable circuits which respond to the environment. Holmes (2002, 199) quotes Mumma's explanation of the piece: the performer plays a French horn with brass and reed mouthpieces, and the circuit "monitors the resonances of the horn in the performance space and adjusts ... to complement these resonances".

We must return to Alvin Lucier as the composer who most single-mindedly applied himself to exploration of resonance: after *Shelter* and *Vespers* came a number of works which more broadly explore air- and structure-borne resonances. The prose score for *Chambers* (1968) begins with the instruction "Collect or make large and small resonant environments ... Find a way to make them sound" (Lucier 1995, 304). This direction is accompanied by a long list of possible "environments", such as "sea shells ... tombs ... cabins ... wells ... cacti ... cars", and means of playing them such as "rubbing ... breaking ... swinging ... bouncing ... poking". Exhibitions and performances of the piece have taken place using small loudspeakers inside objects such as vases, ringing the resonances of these small "environments" with sounds of the performer's choosing. On one occasion, Lucier activated the resonances of a briefcase with the sounds of a trip on the commuter railroad between

New Haven, Connecticut and New York City. The briefcase realization in particular, and the concept of *Chambers* generally, connect with Robert Morris's 1961 sculpture *Box with the sounds of its own making*, a simple walnut cube closed on all sides, containing a speaker which plays a recording of the three-and-a-half hour process of building the box (and Morris's box in turn connects with Marcel Duchamp's 1916 object *With Hidden Noise*, a hollow ball of twine fixed between two brass plates, an unknown soundmaking object contained within).

I am sitting in a room (1969) is probably Lucier's best-known work, and can be situated squarely between the interests of the drone minimalists such as La Monte Young and Phill Niblock, who were exploring the interaction of space and sound, and the process-oriented minimalism of composers such as Steve Reich and Philip Glass, who were working with those techniques from the mid-1960s. *I am sitting in a room* employs a feedback process which gradually reduces the recording of a text to a play of overtones which make up a "portrait" of both the speaker and the room. Through a process of repetition and re-recording, all that remains after numerous iterations are those frequencies contained in the speaker's voice which are also favoured by the acoustics of the room. As Lucier (quoted in Simon 1990, 196) has described the piece, "Every room has its own melody, hiding there until it is made audible. You know, I feel as though we're in the same situation as composers were when they first began perceiving overtones. [...] Now we're just beginning to compose with architecture in mind, and I'm very pleased to be in on these first experiments". Lucier produced a variation on *I am sitting in a room* with his *Quasimodo the Great Lover* (1970), which specifies a chain of linked rooms over as great a distance as possible, each room containing a loudspeaker and a microphone which further modifies an input signal to be based on the "music of the humpback whale" (Lucier 1995, 326-330). Lucier was inspired by recordings of whale song he heard in 1969, in a lecture by whale researcher Roger Payne: not so much by the quality of the song but by the notion of the whales using their songs to communicate over vast distances, "across ocean basins in some

instances [...] by echoing their sounds within a specific temperature layer in the sea so that the sound doesn't get absorbed into the bottom of the ocean or dissipated out through the surface" (Lucier 1995, 110).

Of the many Lucier works which resonate with *Rainforest*, however, none resonate quite so sympathetically as *The Queen of the South*, because its means are so similar, and the year of its creation is 1972, one year prior to *Rainforest 4*. Tudor's work exploits physical objects as filters, revealing their idiosyncratic acoustic signatures aurally; Lucier's *Queen* makes structure-borne sound *visible*, following on the Chladni plate demonstrations so frequently seen in physics classes:

Sing, speak or play electronic or acoustic musical instruments in such a way as to activate metal plates, drumheads, sheets of glass, or any wood, copper, steel, glass, cardboard, earthenware or other responsive surfaces upon which are strewn quartz sand, silver salt, iron filings, lycopodium, granulated sugar, pearled barley or grains of other kinds, or other similar materials suitable for making visible the effects of sound. Surfaces may be excited by making sounds through nearby loudspeakers, directly coupled audio transducers, or directly on or very near the vibrating media themselves. (Lucier 1995, 350)

As the musicians play, the strewn materials vibrate across the surface of the chosen medium, forming into shapes defined by its resonant nodes and antinodes, which vary with the frequencies and amplitudes of the input signal. In Lucier's work, the shapes become a graphic score for the players, who are to use them—detected by video cameras and viewed on monitors—as a guide to continuing their performance, thus establishing a visual/aural feedback loop. Included in the prose score for *Queen* is a suggestion which links it more directly to *Rainforest*:

Take sounds from the vibrating media by contact, vibration or air microphones in order to discover and amplify changes in the original sounds due to the physical characteristics of the media through which they travel and for purposes of single- or multi-channelled playback during performance or recording on electromagnetic tape. (Lucier 1995, 352)

Lucier's instructions also invite use of liquids which can make sound visible, as well as proposing the performers "From time to time, apply fire and ice to the vibrating surfaces to [...] alter their characteristics" (Lucier 1995, 352).

Tudor, "Nature", Chance, and *Rainforest*

David Tudor was familiar with Lucier's work, and had on one occasion performed a version of Lucier's earliest "experimental" piece, his 1965 *Music for Solo Performer*, which uses the performer's brainwaves to activate speakers which in turn resonate percussion instruments (Tudor 1989). In an interview almost 25 years later, Tudor gave a broad description of his own practice, defining it in respectful contrast to Lucier's interests:

My experience with Alvin is that he approaches things more like a romantic, so that he's an appreciator of these phenomena, and he appreciates their specific beauty. Then, when he goes to compose the work, he wants to display those characteristics, which seem beautiful to him. Whereas, in my case, I want to show it as something in nature. You know, I don't want to display it, I want it to display itself, you see. (Tudor 1989)

This statement suggests Tudor took a Cageian stance towards appreciating things and sounds "as they are". Tudor was one of Cage's primary resources for professional performances in the 1950s and 1960s, and he surely understood Cage's rationalisation for adopting a practice of

music-making which professed to be devoid of intention. Far from being devoid of emotional content, Cage (1961, 10) explained appreciation of his music based on chance operations, in terms of appreciation of "nature":

Does not a mountain unintentionally evoke in us a sense of wonder? otters along a stream a sense of mirth? night in the woods a sense of fear? [...] Emotion takes place in the person who has it. And sounds, when allowed to be themselves, do not require that those who hear them do so unfeelingly.

Reading Tudor's statement on Lucier closely, there is an important difference evident between his and Cage's relationships to "nature" which is as significant as the divide between Tudor and Lucier. In the 1950s, when Cage began to compose music using chance operations, he described his intentions (paraphrasing Ananda Coomaraswamy) as being "to imitate nature in her manner of operation, and nature operates from chance" (Cage 1957). Tudor, as Cage's leading interpreter of the time, had the responsibility of turning chance operations into viable performances, which he often did by constructing ordered, fixed notations for himself.

While Cage and Tudor might have agreed that "nature" exhibited chance behaviour, they differed greatly in their professed relationships to it. Unlike Cage, who aspired to *imitate* nature, Tudor expressed a conviction that he *was* nature. In an interview with engineer Billy Klüver (1979) Tudor said: "It seems to me that the way I use the technological medium, it is just more of what's already there". Tudor worked with analog electronics, not only because computers were less accessible at the time, but because the binary language of the computer for him represented a restrictive notion of the nature of sound. A computer's behaviour can be only pseudo-random; Tudor depended on the complex interconnections of many devices, often handmade, which had an unpredictable liveliness when brought together. His role as performer was often to channel that liveliness, navigating through a topography of possibilities latent in the

configuration of his devices. This differs radically from Cage's controlled chance. In his own work, Tudor was an improvising musician, and improvisation was generally anathema to Cage, due to the ease with which players could fall into musical cliché. In the complex situations which Tudor constructed, he generally denied himself that possibility: the labyrinthine system's instability made it difficult to "fall back" into familiar patterns. Accepting the challenge of the unstable "nature" of the circuit was a means of ensuring the sounds remained "themselves" in a Cageian sense. One might picture Tudor as a kind of herdsman, nudging electrons along their many paths: this was his relationship to the medium, described in the name of the group which performed *Rainforest 4* so many times: "Composers Inside Electronics". This relationship to his materials is explicit as early as his 1966 piece for Experiments in Art and Technology's 9 Evenings of Theatre and Engineering: "*Bandoneon !* uses no composing means; when activated it composes itself out of its own composite instrumental nature" Tudor 1966c)

Tudor's sense of oneness with nature may have come from his artistic practice, which he felt attuned him to a deep sense of nature as it really was. This perhaps highlights the scientific side of experimental music (following Cage's definition) which focuses on "sounds as they are" while using the descriptive language of the physics of sound: terms like resonance, oscillation, frequency.

Yet for Tudor, this deep sense of nature was perhaps more directly connected with his spiritual science, Rudolf Steiner's Anthroposophy. In a primer for the Anthroposophical initiate, *Knowledge of the Higher Worlds and its Attainment*, Steiner writes "Through her resounding tones, the whole of nature begins to whisper her secrets to the pupil. What he has previously experienced as incomprehensible noise will become an expressive language of nature herself" (Steiner 1904, Ch. 2). In response to Billy Klüver's question "Why do you want to work in nature?", Tudor responded "Well, it's part of my being. It's a question I can't answer because I can't get away from it. I think all of my work has a strong

connection to nature" (Klüver 1979). To John Cage's comment that "David is related to everything else", Tudor responded with amusement, "And a nature boy, besides" (Tudor and Cage 1985).

Tudor was raised in a family with "theosophical leanings", was a member of the Anthroposophical Society of America from 1957, and made several trips to Dornach, the spiritual centre of Anthroposophy in Switzerland (Kahn 2001). On at least two occasions in 1963, he presented programmes of classical and early 20th century piano works in concerts produced by the Anthroposophical Society, in New York City and Spring Valley, NY ("At the Council meeting here there was some question about whether they were not putting in too much utterly unknown modern music", wrote the Society's representative) (Clark, 1963).

"Nature", in the Anthroposophical sense, cannot be reduced to chemical and mechanical properties, but in a vitalistic way is composed of a hierarchy of etheric and astral entities. Many 20th century artists took the philosophy seriously, including Kandinsky, Beuys, and, surprisingly, John Cage. A 1959 letter from Mary Caroline Richards to Tudor provides interesting detail:

[...] he [Cage] asked me to give him something of Steiner's to read. Since I had already previously mentioned to you the possibility + you seemed to be in favour of it, I didn't refuse. I lent him *Knowledge of the Higher Worlds*. He came to visit me a couple of days ago and said he had been doing little other than reading the book—with great interest. He is already finding it "useful" in his teaching, he said! His only trouble is with the "images" (auras, lotus, etc.) No trouble with concepts. He was especially dwelling on that part about regarding yourself as you would a stranger.... (Richards 1959)

Tudor was very closed-mouthed about the spiritual aspects of his art and life, but agreed in 1994 with my suggestion that his performances might be "a kind of meditation, or a way to get involved in a spiritual act" (Tudor 1994). Although unarticulated, it is clear that the affective spiritual

element of his practice suffuses the liveliness of his live electronic music, and we might consider the essential aspects of *Rainforest* as an expression of his self-described oneness with nature. *Rainforest 4* in its earliest years was described by Tudor as an "environmental piece" (Tudor 1974a) and later was frequently subtitled "An Electronic Ecology" in programmes accompanying installations. The 1981 recording of *Rainforest 4* issued as an LP is described in the album's liner notes as "an electroacoustic environment", while other versions of *Rainforest* are there mentioned as using "natural resonant filters" (*Rainforest 2*) or being "acoustically environmental" (*Rainforest 3*) (Tudor 1981). Tudor's conception of *Rainforest* as being connected in various ways with nature and the environment seems to be clear: even in 1967, upon the commission of the first version of *Rainforest* to accompany Merce Cunningham's dance *RainForest* (the title of the dance came first), Tudor is reported by David Vaughan (1997, 163) to have said "Oh, then I'll put a lot of raindrops in it". Cunningham's choreography itself was informed by anthropological writings about forest-dwelling pygmy peoples, and the title harkens back to his youth in the rainforested Olympic Peninsula in Washington state. (Vaughan 1997, 162)

Another possible source of imagery and inspiration for Tudor may in fact have been John Cage, during their collaboration on the 9 Evenings of Theatre and Engineering in 1966. Tudor's loudspeaker-objects for his piece *Bandoneon !* were mounted on stands atop movable carts. Cage's contribution to the Evenings was his *Variations VII*, which combined environmental sounds phoned in from around New York City with the locally-produced sounds of small household appliances, radios, oscillators, and other sources. Cage and Tudor performed *Variations VII* along with David Behrman, Anthony Gnazzo and Lowell Cross. From the development stages of the 9 Evenings, an interesting handwritten memo exists, from Cage to Tudor. Apparently a set of spontaneous ideas for his upcoming piece which he wished to share with his longtime collaborator, Cage wrote:

[sounds ...] from a hanging mobile materialistic garden with fans making objects (metal, glass, plastic, stone) collide + mikes; [...] + electronic SOS (not manipulated but tuned in so to speak i.e. feedback, single static frequencies, no quasi melodic deals)" (Cage 1966)

The image of a "garden" of objects playing themselves, combined with amelodic "single static frequencies", suggests much of what was to come with *Rainforest*. Tudor is too often eclipsed by the more gregarious and self-promotional Cage; I do not wish to suggest that Cage may be directly responsible for *Rainforest's* development, but the imagery of Cage's note seems too remarkable to overlook.

From all the evidence it seems clear that the piece *Rainforest*, from its earliest version, was intimately bound up with the programme suggested by its title. Tudor's willingness to be directed by chance as embodied in the physical configurations of devices, is evident in *Rainforest*: in its earliest version, the performance is a process of experimentation with oscillators in combination with objects. Because the settings of the oscillators are not exactly repeatable, chance meetings of variable input frequencies and fixed object resonances define the character of the piece. In later versions, the variability of sound sources and ultimately the multiplicity of performers ensure that chance plays a strong role in the audience's and the musicians' experiences of the piece. At the same time, the character of the piece is clearly defined by Tudor's main concern: revelation of the acoustically transformative properties of objects, using a diversity of sonic resources. It is a game of bringing together multiple "natures". With *Rainforest*, Tudor found a unique niche among the wide range of artists and composers of the 1960s and 1970s who also drew upon exploration of the physics of sound for inspiration and invention.

Chapter 2

**PRELUDES TO RAINFOREST:
FLUORESCENT SOUND (1964) AND *BANDONEON !* (1966)**

I was working in electronics a great deal and at one point when I was working on an electronic set-up, the thought came into my head, 'well, this is mine', you know, 'this belongs to me.' At that point, I signed my name to the composition. [...] The first time was 1964 although the first one I actually signed my name to was *Bandoneon* in 1966. But the first piece was actually in 1964 which was done at the Moderna Museet in Stockholm. (Tudor 1988b)

[...] I had no intention of composing anything and signing my name to it, but now it appears that I should have. Because in fact that was my first composition that I could claim as my own. (Tudor 1994)

Fluorescent Sound: Introduction

Fluorescent Sound is important to examine as part of a study of *Rainforest* because it provides a conceptual and technological link between earlier works in which Tudor used contact microphones to amplify small sounds (exemplified by Cage's *Cartridge Music*), and his development of the first *Rainforest*-type loudspeaker-objects for *Bandoneon !* in 1966.

Fluorescent Sound, which David Tudor refers to as his "first electronic piece" (Tudor 1994), was in fact made as an impromptu contribution to a collaborative performance with Robert Rauschenberg on September 13 1964, of Rauschenberg's "happening"-type piece *Elgin Tie*. The venue was the Moderna Museet in Stockholm, and the event was part of "Five New York Evenings" organized by the Fylkingen Festival and Museet director Pontus Hulten, celebrating performance works from across the Atlantic. Both Tudor and Rauschenberg were connected with Merce Cunningham's dance company, which was also presented during the series: Tudor as musician, and Rauschenberg as designer.

Tudor, Rauschenberg, and Klüver

Rauschenberg appears to have been an important link for Tudor to the world of technological art; throughout the 1960s Rauschenberg produced

innovative, technology-heavy works, many of which had a particular emphasis on, and sensitivity to, sound. *Oracle* (1962-65), for instance, included five continuously self-scanning radio receivers embedded in sculptures made from found objects; viewers could interact with the piece by changing the volume of each radio, and its scanning speed. These works depended on the collaboration of engineers, particularly Billy Klüver of Bell Laboratories, who also became close with Tudor and worked with him over more than a decade on several large-scale projects supported by Experiments in Art and Technology, the organisation which Rauschenberg and Klüver co-founded.

Tudor and Rauschenberg had a long history of working together in experimental intermedia performance: both were part of the seminal "happening", known as *Theatre Piece No. 1* or *Black Mountain Piece*, a chance-organised performance which John Cage orchestrated at Black Mountain College in North Carolina in 1952, with Tudor playing piano (Cage's *Water Music* (1952)), Rauschenberg playing gramophone, Cage lecturing on Meister Eckhardt, Cunningham dancing and poets MC Richards and Charles Olsen reading their work (Vaughan 1997, 65-68).

On June 20 1961, Rauschenberg presented a similarly anarchic collaborative performance at the United States embassy in Paris entitled *Homage to David Tudor*, in which Tudor again played Cage on piano (*Variations II* (1961)), along with Niki de Saint-Phalle creating "shooting paintings" (made by firing a rifle at the canvas), live painting by Rauschenberg, whose canvas was amplified with contact microphones, and "a mechanical stripper" by Jean Tinguely, which roamed the stage (Tompkins 1976, 228). Contact microphones amplifying performers' actions were a feature of many Rauschenberg performance works, and he also made use of unamplified, distributed sounds: for instance, a shopping cart full of ticking clocks to be wheeled through the audience, or a number of alarm clocks concealed in a performer's costume, timed to go off at some point during the performance, both a feature of 1965's *Spring Training* (Sundell 1984, 31). The roving cart of clocks in particular

seems to prefigure Tudor's use of mobile, autonomous loudspeaker-objects in his 1966 *Bandoneon* !.

Billy Klüver, the gifted electronics engineer who assisted Rauschenberg, saw a role for himself and other engineers as facilitators of artists; the artists could produce technological problems for the engineers to solve. Klüver and Rauschenberg's first collaboration was *Dry Cell* (1963), a sound-responsive sculpture in which a small propeller-like piece of metal is set spinning when viewers interact with a microphone embedded in the piece. *Oracle* (1962-65) was a much more ambitious installation work incorporating six large metal sculptural objects and continuously-scanning radios with which the public could optionally interact, through a panel of knobs and dials; the effect was one of a continuously-changing media soundscape, recalling Cage's earlier works for chance-tuned radios (as well as Tudor's anecdotal preference for practising piano simultaneously with several radios tuned to different stations). *Soundings* (1968), a large mural-like work made with several layers of silkscreened plexiglass, was also voice-sensitive: four banks of lights illuminated different layers of the piece depending on the frequency content of the input; and *Solstice* (1968) was a corridor of double sliding plexiglass doors, each silkscreened with colourful images, which parted for the approaching visitor and thus formed an ever-changing multilayered visual experience, using technology familiar from the office building and the supermarket. A large-scale 1970 work *Mud-Muse* (created not with Klüver and E.A.T. but with the Los Angeles County Museum of Art's "Art and Technology" program), used sound as a trigger for air bubbles which burbled up through 1000 gallons of thick mud (Tuchman 1971, 279-288).

Billy Klüver (2002) also made connections with the Merce Cunningham Dance Company, as they sought to technologize performances:

I heard about activities within the art world and the explosion that happened after the abstract expressionists of Manhattan, and I was interested in becoming part of it, so the only thing I could add was technology that I knew at Bell Labs where I worked [...] Now John

Cage and Merce were the, I should say, top of the list, and since Robert Rauschenberg made the sets and went on the world tour, it became obvious to meet with John Cage and Merce. And so personally I went to New London and to other places where they danced, around here, and followed them as they appeared around Manhattan. [...] And so with Robert Rauschenberg on one side, John Cage on the other, it was inevitable to become friends with David Tudor. Robert Rauschenberg is a great talker, John Cage is a great intellectual, and David is just like grey matter in between. And it was very easy to become friendly with him. No pretensions, nothing.

In 1965, by which time Rauschenberg had taken leave of the company as designer, Klüver participated in the technical realisation of Cunningham's *Variations V*, designing photocell switches which the dancers would trigger as they moved through the space. In Cunningham's description, "The dancers triggered a sound, but the kind of sound, how long it might be, or the possible repetition of it, was controlled by the musicians, who were at the various machines behind us—tape recorders, oscillators, shortwave radios—there were about 8 men on the platform" (Vaughan 1995, 150). These musicians included John Cage (whose work *Variations V* was being performed), Gordon Mumma and David Tudor. Klüver later collaborated with Andy Warhol on the décor for Cunningham's 1968 dance *RainForest*, helping to find a means of realising Warhol's image of silver mylar pillows hovering untethered about the stage.



Figure 2-1. David Tudor performing John Cage's *Water Music*, "5 New York Evenings", Moderna Museet, Stockholm September 10 1964. Note contact microphone (phonograph cartridge) attached to handle of watering can. Photo courtesy Moderna Museet.

Fluorescent Sound:

Between Cartridge Music and Rainforest

David Tudor's collaboration with Rauschenberg at the Moderna Museet seems to have come about spontaneously; certainly, if they had planned in advance to work together, Tudor appears to have left the planning for his contribution to the last minute:

Rauschenberg [...] asked if I would do the music. I said yes and I walked around the museum and thought, 'what am I going to do?' I noticed that there were—it must have been—a thousand fluorescent light bulbs. One day I was in the room when someone was turning on the fluorescent lights and they didn't know which to turn on and all of a sudden there was the most beautiful music. I thought, 'OK, I'll put some contact microphones up there from the bulbs to see if the sound can be made really audible.' (Hultberg 1998)

If the idea for the piece came quickly, its realisation was not equally rapid. Tudor related, "I had to get up on a large ladder and place the contact microphones which actually took nearly three days. Fortunately I had help to do it because there were, I believe, 75 switches with three light bulbs on each switch. It was a big job. It worked very beautifully" (Tudor 1988b).

In a 1994 interview Tudor described the score for *Fluorescent Sound*:

[...] there were two different versions [...] I discovered that the acoustics in the Museum were quite extraordinary. There were two spaces, one of them is the [...] foyer, and behind that there's a very large room. So I first experimented with contact microphones in the foyer and [...] I examined the switchbox, I found out which circuits would control, and it turns out that one switch in the foyer would control six bulbs, and it was slightly different in the larger room, that was the reason I had to make two scores, so my score's just switching on and off these bulbs". (Tudor 1994)

Little documentation remains of the work. During the same interview, Tudor stated that the score he notated for switching on and off the lights was at the time among his papers at his Stony Point home. All of Tudor's papers from Stony Point were acquired by the Getty Research Institute, but the *Fluorescent Sound* score has not yet been identified among them.

No audio, video or film documents of the Moderna Museet performance have yet been unearthed, which might give a better understanding of Tudor's contribution.



Figure 2-2. Robert Rauschenberg performing *Elgin Tie*, "5 New York Evenings", Moderna Museet, Stockholm September 13 1964. Note recessed banks of fluorescent lights overhead, used by David Tudor for accompanying piece *Fluorescent Sound*. Photo courtesy Moderna Museet.

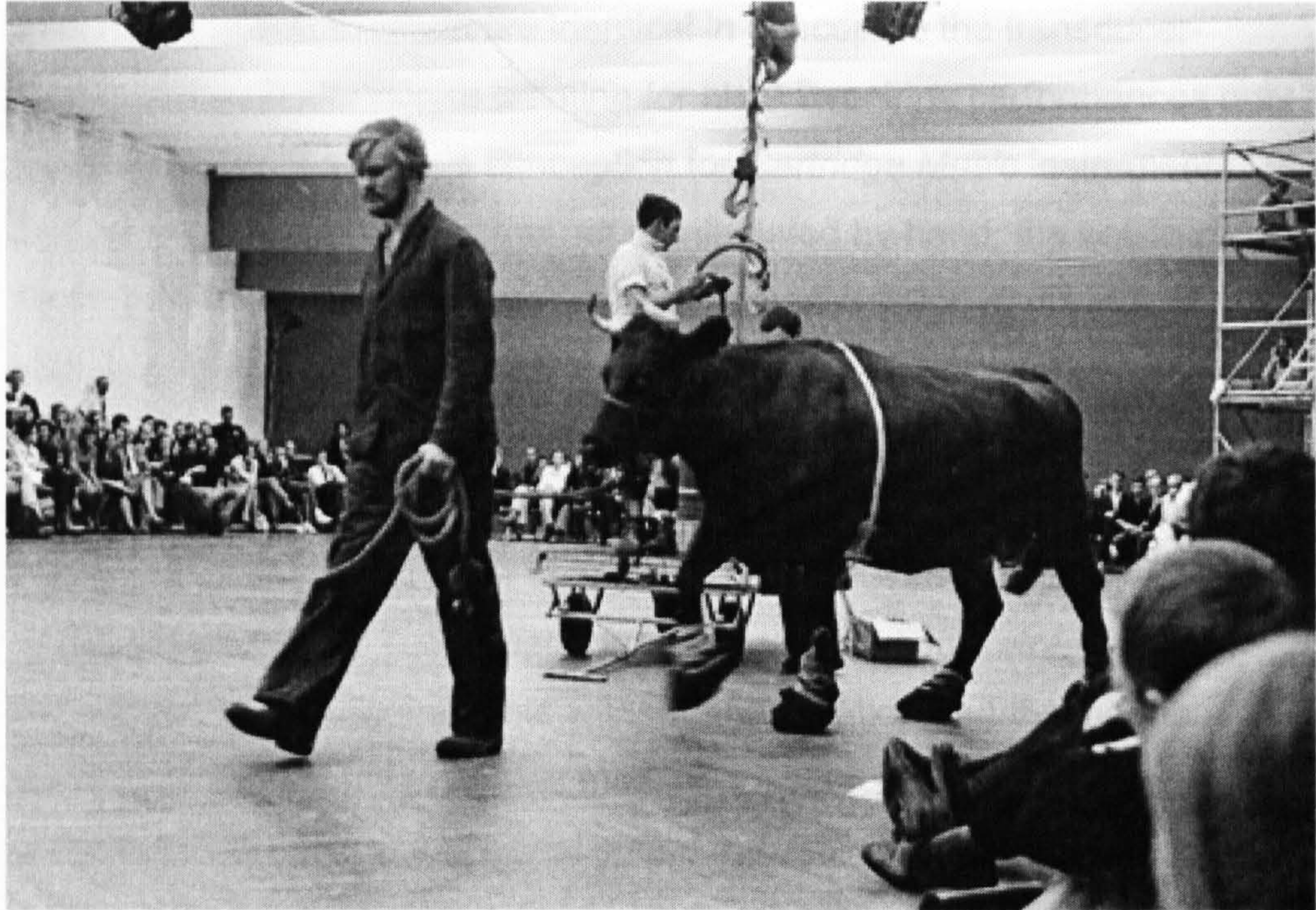

Figure 2-3. Robert Rauschenberg performing *Elgin Tie*, "5 New York Evenings", Moderna Museet, Stockholm September 13 1964. Note recessed banks of fluorescent lights overhead, used by David Tudor for accompanying piece *Fluorescent Sound*. Photo courtesy Moderna Museet.

If we examine the concept of Tudor's "first piece", it clearly seems to bridge his work with contact microphones in realisations of others' pieces—especially John Cage's *Cartridge Music* and *Variations II*—and his work which was to come with transduced objects as loudspeakers. It is worth noting that according to Christian Wolff (1996, 51-52) Tudor had on one occasion led a class at Darmstadt in an *acoustic* performance of *Cartridge Music*, using "objects that would serve as resonating chambers," rather than contact microphones and amplifiers.

The fluorescent tubes of the Moderna Museet are, on the one hand, *Cartridge Music*-type instruments: their small sounds are amplified to bring them into the realm of the readily perceptible (although Tudor (1994) says the piece was still "very quiet" so as not to disturb the bull which also took part in Rauschenberg's *Elgin Tie*). But the fluorescent tubes might be better understood as proto-"*Rainforest objects*", because

their use and amplification are identical in concept to the transducer-loudspeakers Tudor began creating for his 9 Evenings performances only a year later. Unlike Cage's conception for *Cartridge Music* instruments, Tudor's fluorescent tubes were not manipulated by hand; the action of flipping switches was a remote, electronic manipulation of objects whose glassy resonant characteristics coloured impulse-like flickerings of electricity, which activated the gases in the tube much the same as vibrations of a transducer would activate a solid object. The resulting sounds have been described as bell-like (Sundell 1984, 12). As with the loudspeaker-objects Tudor made for *Bandoneon !* and *Rainforest*, the fluorescent lamps were audible without amplification, but the laborious addition of contact microphones made it possible to enhance their presence through a conventional sound system. Fluorescent lighting circa 1964 depended on a starter circuit which over a period of several seconds provided initial power to the main lamp's filaments, before a surge of power from the ballast (a type of transformer) caused it to light. It is curious to think of these lights as period instruments, but a recreation of *Fluorescent Sound* as proposed by John D.S. Adams and D'Arcy Phillip Gray (1997) would necessarily be technologically quite different from the original.

Until Tudor's score for *Fluorescent Sound* is identified from among his materials now with the Getty Research Institute—if it is in fact there—we can only guess what form it took. Tudor (1994) himself said "I had no intention of composing anything and signing my name to it, but now it appears that I should have. Because in fact that was my first composition that I could claim as my own. [...] the only documentation that I have was that I had the diagrams of the switch boxes". This comment suggests that the score may have been merely a guide to the mechanics of the instrument which Tudor had constructed out of the museum's lighting, rather than a list of timings for specific events; certainly Tudor had a much warmer relationship to improvisation than did Cage, and expressed in an article based on an interview that "notation [...] can't possibly be complete. Notation is an invention of the devil, and when I became free of

it, through pieces like Cage's *Fontana Mix* and *Music Walk*, and later Bussotti's *Piano Piece for David Tudor No. 3*, it really did a lot for me" (Tudor 1972b, 24-26). That Tudor attributes his "liberation" to these works, which premiered in 1958 and 1959, might seem surprising, but we can understand their graphical score materials, requiring interpretation by the player, as signposts for Tudor on the road to identifying himself as composer in his own right.

Experiments in Art and Technology:

The 9 Evenings of Theatre and Engineering, 1966

Rauschenberg and Klüver were the co-founders of Experiments in Art and Technology, an organization dedicated to fostering collaborations between artists and engineers, which was officially formed in 1966 following its first major production, the 9 Evenings of Theatre and Engineering at the 69th St Armory in New York City. Klüver (2004) said "above all, it was Rauschenberg's commitment to the collaboration that provided the spirit and the energy that made it all happen". Not only spirit and energy; Rauschenberg's success in the art world enabled him to provide substantial material support to E.A.T. as well. Already on close terms with Rauschenberg and Klüver by that time, Tudor received an invitation to join the new organisation's board of directors and propose a work for the 9 Evenings. He was to remain intimately connected with E.A.T. throughout the 1960s and 1970s, and his roles in E.A.T. initiatives sustained him, both intellectually and materially, in much of his work well into the 1980s. As I will discuss further in Chapter 4, the sonic identity of Tudor's *Rainforest 3* (1972) is essentially defined by field recordings collected for his work within E.A.T.'s pavilion for the Pepsi Corporation at the Osaka World's Fair 1970; and Tudor's exploration of sound generation with acoustic and electronic feedback loops in Osaka led to several major works created between 1972 and 1974. *Untitled* (1972) and *Toneburst* (1974) both use principles of sound generation via electronic feedback, without external signal input. *Microphone* (1973) uses acoustic

feedback bursts and was developed at Mills College, Oakland California, based on a first version of the piece made for the Pepsi Pavilion.

Billy Klüver (2002) has spoken about the importance of the metaphor of the rainforest for himself and the others at this time: "the rainforest is significant because there is no ground, there is a very shallow earth level in which the plants live. So they're essentially floating on the earth, on top of earth, and then everything grows inside it. Well that idea I did find very interesting in the arts". Klüver wrote an article entitled "Rainforest", (1970) explaining the philosophy of E.A.T. in terms of a rainforest ecosystem:

The rainforest is made up of thousands of feedback loops of continual activity. Thousands of animals, plants and trees live in the rainforest. Its roots are few and shallow as opposed to the oak tree's deep roots in the ground. The oak tree takes energy out of the ground and shades the area so that no small bush or flower can grow near it.

The main purpose of Experiments in Art and Technology is to develop, through experimentation and experience, fluid organizational forms whose model is that of the rainforest rather than the oak tree.

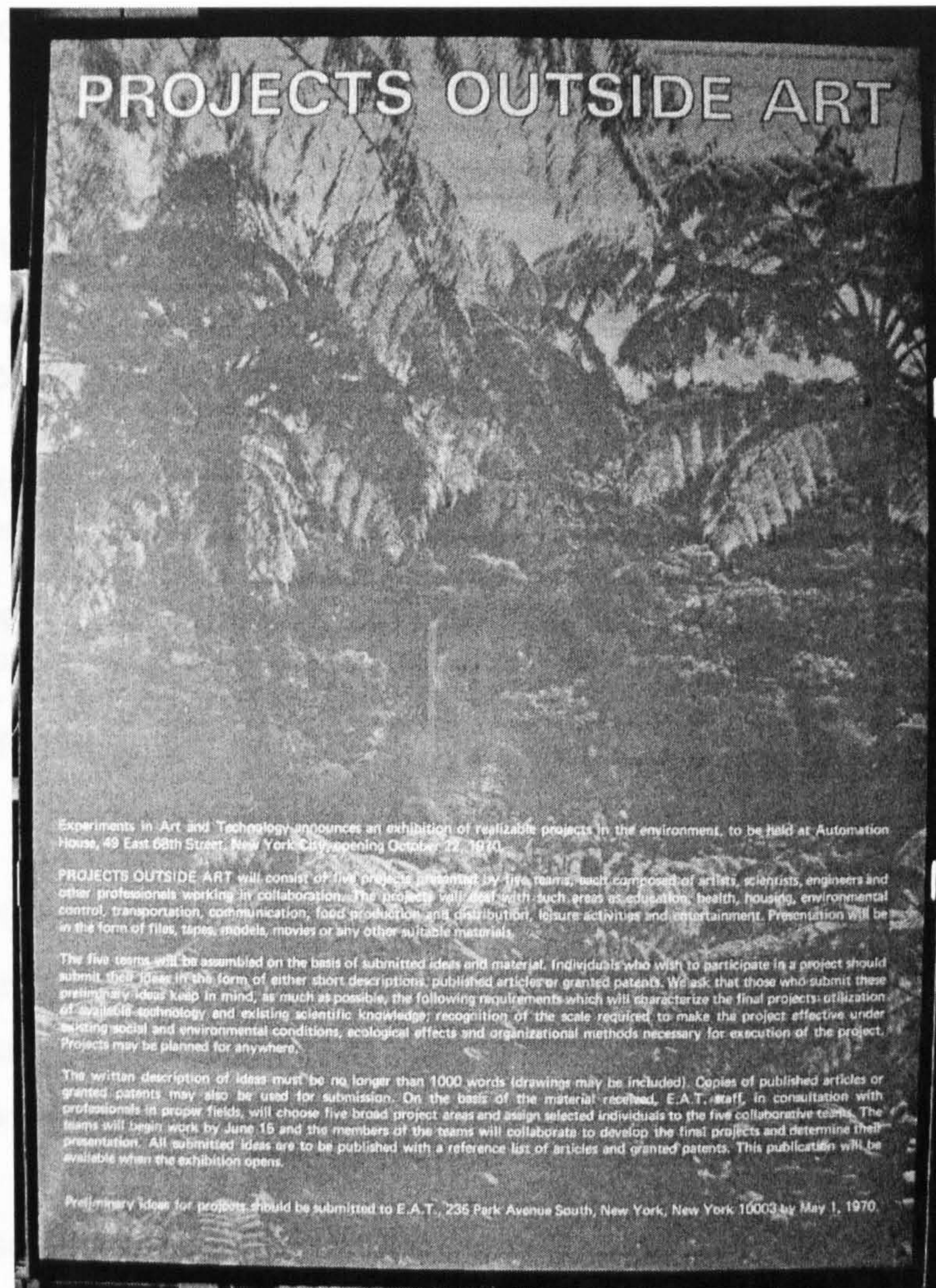

Figure 2-4. Poster for "Projects Outside Art" initiative, Experiments in Art and Technology 1969-1971, employing rainforest imagery (E.A.T. 1970).

E.A.T.'s adoption of the metaphor of the rainforest seems not to have come about until after Merce Cunningham's dance *RainForest* in 1968; Klüver (2002) indicates, however, that the rainforest metaphor was "in the air" among his group of friends, artists and engineers in 1968 or earlier, and that it would be difficult to establish an initial source for the concept:

[...] the concept of the rainforest, as a self-sustaining growth, was there. I don't know who was first, if it was Merce with his dance [...] Could have come from John, I don't know. Someone introduced it. Our community in New York was not *a priori* intellectual [...] It was almost impossible—well, since I am not an artist—to have an intellectual talk, discussion with somebody, at that time. [...] And I

know that we had the idea of rainforest [...] But where it came from I do not remember.

David Tudor, in an interview with John Fulleman (Tudor 1984); recalled that as early as 1965 he had imagined the use of physical objects as acoustic filters, in a large-scale distribution:

I recall I was asked to make a project for a Washington park, who wanted to have a more or less permanent sound installation. It was an opportunity to make a project, and I didn't know if anything would happen and eventually nothing did happen. But what happened was that my mind started working and I thought that what I would like to do would be to make an orchestra of loudspeakers all having different 'voices' which would all receive a common input.

Tudor (1984) also mentioned that part of his idea for the park installation involved "a machine [...] able to switch amongst signals and outputs", presumably so the "common input" could be directed to each loudspeaker independently, in an automated manner.

The description of the project Tudor envisioned for the park—which remains unidentified, as I have found no records of any formal discussion of the project in Tudor's papers—fits well with his later description of *Rainforest 2*, performed circa 1969-70, in which a single human voice was used as input to a number of loudspeaker-objects simultaneously; it seems likely that *Rainforest 2* was a return to the idea behind the unrealized park project.

It is unclear whether Tudor would have had the technical means for realizing loudspeaker-objects, if the park project had proceeded in 1965. What is known is that around this time, he was actively pursuing those means, or at least taking advantage of circumstance. Among Tudor's papers is a copy of an article from the May 1960 issue of *Electronics World* introducing an innovative audio transducer device. "The 'Bi-Phonic Coupler': A unique hi-fi speaker system", is described as a "speaker voice

coil sandwiched between two thin wooden layers in a slim box [...] One unusual application of this speaker involves its installation into the headboards of a twin bed, providing stereo reproduction in the bedroom!" (Cohen 1960).

Also among Tudor's papers is a copy of the December 1965 issue of *Popular Mechanics* which includes a prominent article with headline in large type exclaiming: "Fantastic coneless loudspeaker! Turns doors into speakers! Fills swimming pools with sound... makes desks into speakers... washes your clothes! Costs 38 cents!" (Popular Mechanics 1965). The article details the amazing properties of this device, design patented by one William Ashworth, which apparently could be simply constructed: "Complete details of how to build your own will appear [in *Popular Mechanics*] early next year". The claim that this device could wash clothes was not an attempt at over-the-top humour: the article actually discusses the use of such a coneless speaker attached to a washbucket, to agitate dirt out of clothes by means of low frequencies. More pertinent to Tudor's interests would have been the description of speakers made of "a door, mirror, window, phonograph lid or any firm panel of wood, plastic or metal".

Unsurprisingly, the follow-up issue of *Popular Mechanics* with the promised coneless loudspeaker design is also among Tudor's papers (*Popular Mechanics* 1966). Six months elapsed between the issues, during which time it seems that Tudor contacted William Ashworth and visited his production facility in New Albany, Mississippi, to obtain a number of his "Ashworth Sound Reproducers": "I went to see the manufacturer of these devices and they gave me several samples. They later produced a commercial version" (Tudor 1988a). I have found no evidence that Tudor actually attempted to build any "coneless loudspeakers" from scratch, using the design in the June 1966 *Popular Mechanics* article; it is evidence of Tudor's interest in the idea, however, that a copy of the same article from the Spanish-language edition of

Popular Mechanics in September 1966 is also found among his papers (*Mecánica Popular* 1966).

We do not know the exact date when Tudor's imagination began working on the possibilities for the Washington park installation, only that he has said "My piece 'Rainforest IV' was developed from ideas I had as early as 1965 [...] that the loudspeaker should have a voice which was unique and not just an instrument of reproduction, but an instrument unto itself" (Tudor 1988b). Billy Klüver (2002) said of Tudor that he "kept up by buying these [hobbyist electronics] magazines, like one step below the [professional electronic engineering] ones that I subscribed to", and I believe it is not far-fetched to suggest that his conception of the loudspeaker-object may have been brought about by an encounter with the December 1965 *Popular Mechanics* article.

We cannot know whether Tudor already had in mind the idea of the sounding object, the acoustic filter. Perhaps the article merely suggested a practical means of achieving a "dream-vision of an orchestra of loudspeakers" (Tudor 1989) which Tudor had already experienced. He related how the "vision" came well before a means of realizing it: "I thought, you know, 'How am I going to do this? How am I going to do this?' And so, I kept my eyes out for some means which would enable me to start working on this, in order to realize it within ten years, twenty years, whatever it would take" (Tudor 1989). Whether the *Popular Mechanics* article inspired Tudor's conception of the loudspeaker object, it seems at least to have informed him of a means to realize it technically, and the transducers employed in his *Bandoneon !* of October 1966 were likely the Ashworth Sound Reproducers obtained directly from their inventor.

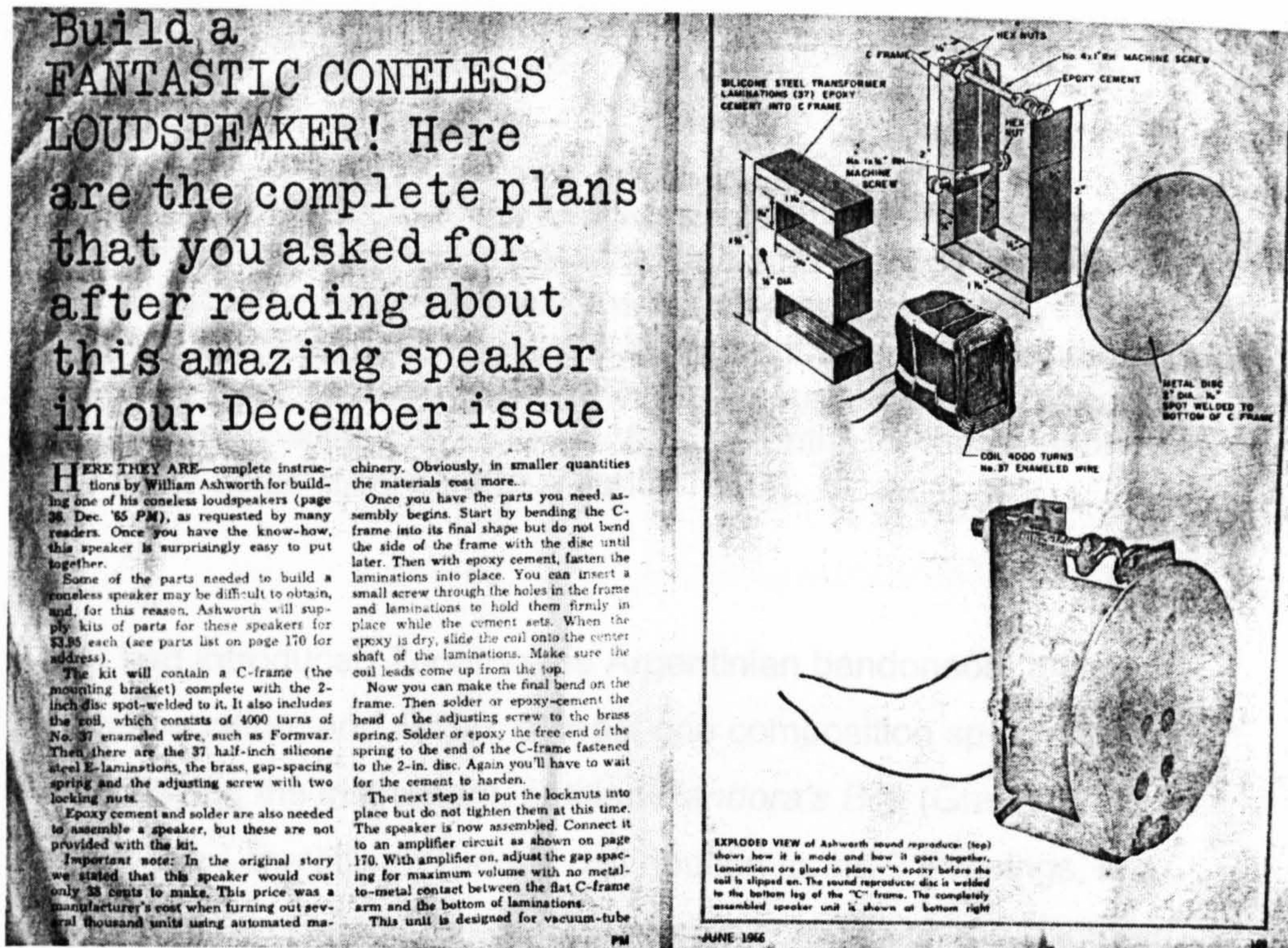

Figure 2-5. "Build a fantastic coneless loudspeaker!" (*Popular Mechanics*, 1966).

As an additional note, Lowell Cross suggests Tudor may have been influenced by Alvin Lucier's use of speaker-activated percussion instruments in his 1965 *Music for Solo Performer*, which uses the performer's brainwaves as impulses to resonate the instruments (Cross 2004). It should be noted that Lucier has always used conventional loudspeakers coupled with the percussion instruments; Tudor performed the piece at least once, in 1967, without Lucier's involvement, also using conventional loudspeakers rather than *Rainforest*-type transducers (Tudor 1989).

Tudor's intention to include transducer-loudspeakers in *Bandoneon!* seems to be evident from its early planning stages, but his primary sound image for the piece did not focus on them as critically important. Although Tudor was taking on this project for the 9 Evenings as a composer—the first time he would publicly do this—his intentions at the outset were to

work with and transform performance materials provided by another composer:

[...] my first plan for the 9 evenings was to have been a realization of my friend Mauricio Kagel's Möbius-strip composition 'Alle rechte vorbehalten' using only white noise as a source, gated, triggered etc in a complex fashion by some instrument. this idea abandoned itself thru the process of my projecting my thoughts into the about-to-become available technology, & its potential for the creation of 'white noise' from scratch. (Tudor 1966f)

Kagel had introduced Tudor to the Argentinian bandoneon, a type of button accordion, and written at least one composition specifically for Tudor playing the instrument, entitled *Pandora's Box* (Gray 1997). *Bandoneon !*, the title of Tudor's contribution to the 9 Evenings, is a shorthand for immense, almost unparsable complexity: the "factored" bandoneon was at the heart of the piece not only as sound generator, but also as controller for sound distribution and theatrical lighting. The processing of the bandoneon's audio signal, through at least 18 different circuits, was intended to lead towards the "rebirth of white noise" (Tudor 1966c).

Tudor (1966d) wrote in a note afterwards that the "9 evenings bent the concepts of system-engineering, celebrating the arrival of technology rather than using it: no blame for either engineers or artists". Although the event is remembered as a milestone in the history of media arts, it was at the time a frantic exercise in attempting to make complex technologies work together, with failure as a frequent outcome. This did not deter the participants, nor did it necessarily bother the audience, who of course were unaware of the artists' and engineers' intentions and thus were equally unaware of technical mishaps. Tudor performed *Bandoneon !* twice, on October 14 and 18 1966, and the performances were quite different, owing to various technical hitches and compromises.

Tudor's notes for the 9 Evenings programme book are in two parts: one typeset and one a facsimile of a handwritten note. To some extent, they appear to contradict each other: the handwritten note explains that *Bandoneon !* is "activated by material of Mauricio Kagel - 'Alle Rechte vorbehalten' " (Tudor 1966c). The typeset notes state that "*Bandoneon !* uses no composing means; when activated it composes itself out of its own composite instrumental nature" (Tudor 1966c). Tudor (1966e) wrote elsewhere that "the performance method [was] single performer feedback, which also obviated the need for any compositional means".

Bandoneon !, (bandoneon the production of visual factorial), is a combine incorporating programmed audio circuits, moving loudspeakers, tv images and lighting, instrumentally excited.

The instrument, a bandoneon, will create signals which are simultaneously used as material for differentiated audio spectrums (achieved through modulation means, and special loudspeaker construction), for

the production of visual images, devised by Lowell Cross; for the activation of programming devices controlling the audio visual environment, devised by Bob Kieronski ("Vochrome," and programmed patch-board) and Fred Waldhauer (Proportional Control).

Bandoneon ! uses no composing means; when activated it composes itself out of its own composite instrumental nature.

instrumental loud-speakers (soundings physical materials), actuated by material of Mauricio Kagel - 'Alle Rechte vorbehalten' - in a self-multiplying audio-visual application (towards "rebirth of white noise").

live signals → becoming electronic → programmed transmission to physical materials.

tudor

Figure 2-6. Notes for *Bandoneon !*, from the programme book for 9 Evenings: Theatre and Engineering (Tudor 1966c)

Regardless of what "input signal" was used (and it seems that the Kagel composition was not, in the end, used as source material), what is interesting is that the transduced object is elevated in importance here, and even made central to the piece: the handwritten note begins with the image of "instrumental loud-speakers (sounding physical materials)", and the typeset note references "moving loudspeakers".

The most significant part of the 9 Evenings programme note, which identifies the "instrumental loud-speakers" as central to the piece, is Tudor's final flow-chart notation: "live signals --> becoming electronic --> programmed transmission to physical materials" (Tudor 1966c): the source of control (the bandoneon) and the final means of distribution (the loudspeakers made of "physical materials") appear to have been viewed by Tudor as being of equal importance. Twelve conventional loudspeakers positioned along the balcony of the armory provided the primary means of amplification; they were loud enough to create acoustic feedback situations in interaction with the microphones Tudor was using to pick up the bandoneon's signal. In addition, four transducer-speakers were employed; their signals would of necessity have been weaker than those from the conventional loudspeakers, due to their lower power rating. Tudor explained the function of the transducer-speakers in two interviews:

my first use of them [the transducers] was in the Nine Evenings where I had the possibility to utilize remote controlled carts. There were five of those, so I made five constructions. And I sent sound into them and caused them to run about the room. Besides that I had twelve loudspeakers which were switching the same signals, but this gave me the opportunity for the sound to get very close to the audience and move away from it, so it was like a spatial variation. (Tudor 1984)

I had made a number of large sculptures in the manner of Rainforest. [...] the sounds from the bandoneon also vibrated the sculptures. My idea was that they would be sent around the room, that their sound would circulate. The audience was on three sides, so they would come close to the loudspeakers. And for that, I had to have five operators, seated on chairs, sending the platforms around. They were really radio-controlled carts. (Tudor 1993)

The choreographer and dancer Deborah Hay, another of the 9 Evenings' commissioned artists, developed a work entitled *Solo*, in which eight remote-controlled platforms, or carts, resembling small plinths, were caused to move about the space, sometimes carrying dancers. Tudor's role in her performance was not as a musician, but as sound diffuser, moving sounds amongst the twelve balcony speakers using two light pens and a custom-built light-sensitive control surface designed by E.A.T. engineer Fred Waldhauer, part of a set of electronic performance tools for the 9 Evenings known as the Proportional Control System. Tudor's initial interest in using Hay's carts was not well-received; according to Billy Klüver (2002), because the radio-controlled platforms had been developed for her piece, she was unwilling to have them appear in another artist's performance. This tension was resolved, however—according to Tudor, his involvement with Hay's audio diffusion was done as an exchange of favours (Tudor 1993)—and Tudor did make use of them in one of his two performances of *Bandoneon !*, with the carts controlled by James Tenney, David Behrman and Anthony Gnazzo (Cross 1966). Lowell Cross suggested that the carts were not used in the second performance due to technical problems (Cross 2004).

Tudor carefully considered the resonant materials for his first instrumental loudspeakers. A number of notes exist listing possibilities; the earliest of these appear to date from the summer of 1966, perhaps as a result of Tudor's meeting with William Ashworth. The following is a note made

regarding the specifications of the Ashworth transducer and its usage (Tudor 1966b):

SHEET ROCK, GLASS, PLASTIC, METAL, WOOD
90 - 9000 CPS

plywood, plaster board,
metal (sym. vib if joints)
10-12 w without distortion
1500 sq. ft.
cuts off with 90° angle
40 x 8

This note, found with other materials dated to the summer of 1966, describes the basic information Tudor needed to pursue experimentation with loudspeaker-objects: a basic list of possible materials (as might be used in installation of transducers for a home hi-fi); a notation of the typical frequency response of the transducers, and the maximum power they were able to handle without distorting; and the area which a single transducer might be expected to activate, in optimal circumstances. "Cuts off with 90° angle" may refer to the dampening of resonances at the fixed edges of a wall; "40 x 8" may be a wall area reference. This note reads like a précis of the information booklet accompanying commercial versions of the Ashworth-style transducer, suggesting the information may have been obtained from Tudor's meeting with Ashworth.

Another note (Tudor 1966f) from this era describes materials considered:

sheet rock
glass
wood: masonite
barrel
metal: bronze thundersheet
furniture
try: metal pipe const.
fibreglass
jointed metal const.
Piano

Anyone who has begun to explore the design of *Rainforest* loudspeaker-objects will realize that it requires a process of trial and error; good

guesses can be made about the likelihood of one material or another as a good resonator, but it is in the testing of many types of objects and materials that the best come to light. From Tudor's notes we get a sense of the experimental approach to creating his own first loudspeaker-objects; he later described *Rainforest* as a piece which "teaches itself", (Tudor 1995) and here we have a picture of him as its first student.

In the end, Tudor decided upon five designs for loudspeakers to sit upon Deborah Hay's carts (Tudor 1966b):

carts:	(pictures?)	
	wood	
	metal flag	
	metal pan w/ nails	
	glass	
	horn	
		unaltered signals

The final item in the above list is a large horn-type conventional loudspeaker. In his "Generalized Diagram" for *Bandoneon !* (Figure 2-9), Tudor elaborated on the list of loudspeaker-objects (Tudor 1966d):

4 transducer-speakers constructed from materials of specific resonant frequency:

- 1) aluminum sheets (suspended ca. 15')
- 2) steel tray with vibrating appendages
- 3) 2 - 14' wooden planks mounted at 90°
- 4) plate glass (push-pull driven)

I found it surprising that one of the four loudspeaker-objects was plate glass—in a 1995 interview I conducted with Tudor he specifically told me that "Early on [...] I avoided glass" (Tudor 1995)—but then there are theatrical considerations at play here which perhaps allowed a tradeoff between dramatic visual presentation and an ideally resonant speaker-object (John Driscoll, founding member of Composers Inside Electronics

who participated in most performances of *Rainforest 4* through the 1970s and 1980s, suggested to me that occasionally an object found its way into that version of the piece based primarily on its visual merits (personal communication, May 2000)). Anthony Gnazzo recalls of the transduced glass,

I don't think that one worked. I mean, as I recall, the fact is that the glass is so rigid and the [resonant] frequency was so high that it was impossible to get it to vibrate and make any sound with an audio driver. I mean, he was using various types of speaker coil type things and stuff like that. And it would just kind of flop against the glass. I remember the flop, flop, flop sound. It didn't vibrate like it was supposed to. So, I don't know if that thing even got used. Well, it was impossible to tell anyway, because it was so chaotic—one couldn't tell what was going on (Gnazzo 2001).

Photographic and videographic documentation of Tudor's first performance in the 9 Evenings series shows only three of his transducer-speakers clearly: the wooden planks, the aluminum sheets, and the steel tray, the "vibrating appendages" of which Tudor mentions in one note simply as "nails" (Tudor undated B). In video footage, unfortunately shot without sound, these three objects roam rather comically to and fro across the performance space, moving fairly close to the audience, while in the background Lowell Cross's video projections of Lissajous figures derived from Tudor's sound are displayed. Tudor's performance platform is located stage right, lit with work lights and occupied not only by himself, sitting with bandoneon on his knees, but also by his assistants and engineer-collaborators (see Figures 2-7 to 2-11).

The carts were entirely wireless, not only in their navigation but also in their reception of audio signals: FM transmitters on different broadcast frequencies were picked up by receivers on each cart, and amplified by a battery-powered circuit to a level suitable for the transducers. For the first performance of *Bandoneon !*, Tudor's signal sources for the four loudspeaker-objects were derived from streams of processed sound originating with eight microphones and pickups on the bandoneon itself.

The processing consisted primarily of varieties of amplifiers, many of them in overdriven or oscillating states, some in combination with frequency or amplitude modulation processors, or other forms of signal distortion, in aid of achieving the "rebirth of white noise" (Tudor 1966c). Tudor's diagram, "Bandoneon Factorial Audio Processing & Routing" (Figure 2-10), shows sixteen independent streams of processing of the signals from the bandoneon. Four of these have dotted lines indicating FM transmission to a loudspeaker-object (a fifth dotted line shows a wireless connection to the horn-type conventional loudspeaker).

Other streams show connections to hardware which used Tudor's sound to control its own diffusion through the Armory's twelve conventional loudspeakers, as well as the on/off state of lighting instruments. This was accomplished via two frequency-sensitive devices developed by Tudor's engineer-collaborators on *Bandoneon !*, Fred Waldhauer's "Proportional Control System" and Robert Kieronski's "Vochrome". The latter "spectrally analyses the signal and produces digital outputs corresponding to notes on the tempered scale" (Kieronski, undated), and these on/off states triggered patterns of twelve relays directing twelve input signals from Tudor to the Armory's balcony speakers (recalling the switching system envisioned by Tudor for his unrealised installation project for a park in Washington, mentioned earlier). Additionally, the Vochrome controlled the states of 18 spotlights placed around the balcony. The Proportional Control System was developed as a general-purpose device in which "each of 16 output control variables changes in proportion to its corresponding input control information". Waldhauer wrote that Tudor's microphone signals

[...] were also used as control signals which were used to activate [...] tone and amplitude sensitive proportional control receivers. Both the Vochrome and the proportional control receivers controlled both the lights and processed sound from the bandoneon, so that as David played a certain note, for example, one light would become brighter and dimmer in response to the volume of the tone generated. Another note would change the sound level of one of a dozen altered bandoneon signals in a similar fashion. (Waldhauer 1966)

Acoustic feedback resulted from the balcony loudspeakers interacting with the bandoneon's microphones and pickups, producing what may have been the work's most significant sonic aspect: Tudor could, at least to some degree, control which speakers were on or off at any time, thus he was able to "play the Armory", in Billy Klüver's description (2002):

[...] he had contact microphones on the bandoneon so when he was playing the bandoneon, well the feedback came from the whole armory [...] I remember standing on the balcony one day next to David and he was actually measuring the echo time on the armory itself, and that turned out to be six seconds, which of course was, what's the word, well a treasure for David because he used that six seconds absolutely to the hilt. So did John Cage, of course, but David used it specifically much more. [...] He played the armory, the whole hall, and it was of course a gold mine for him because everything resonated.

A "reset" button on the bandoneon (provided by Kieronski to reset the relay sequence of his Vochrome to its initial state (Chadabe 1993)) was used by Tudor as a cutoff switch, in order to stop the feedback: "The silence was deafening, because the sound in the Armory was extraordinary, so reverberant. Once you started something oscillating, it would go on forever" (Tudor, quoted in Chadabe 1993).

There are no high-quality audio recordings of either of the two performances of *Bandoneon !*; the only recording which I have been able to source is a cassette tape recorded by Ritty Burchfield on a small portable machine, in mono (Tudor 1966a). It is of very poor quality (see excerpt on CD accompanying this thesis) but gives some idea of the expansive nature of the piece; which performance it documents is unclear.

For the second of the two performances of *Bandoneon !*, the roving carts were not used. Tudor included in his diagram of "Bandoneon Factorial Audio Processing and Routing" a depiction of "alternate routing for

transducer-speakers when carts do not move" (see Figure 2-10). This drawing suggests that in the second performance, the loudspeaker-objects received sound directly from contact microphones on the treble and bass reeds of the bandoneon, rather than from Tudor's many streams of processed bandoneon signal. Beyond this difference, what is also interesting to note is that each of the four loudspeaker-objects in this version has its own contact microphone attached, to pick up its subtle resonances. In Tudor's diagram, these signals are shown mixed and then directed through the Proportional Control System to the single horn-type conventional loudspeaker. This small diagram, which appears to be somewhat of an afterthought in Tudor's documentation of *Bandoneon !*, is in fact a blueprint for all versions of *Rainforest* which followed, beginning with Merce Cunningham's commission in 1968. It bears the greatest likeness to the fourth and largest version of *Rainforest*, given the size of the objects used in *Bandoneon !*: the objects themselves are intended to be heard acoustically, but the addition of conventional amplification enhances their presence and may be heard independently as well, as a "cloud" of resonances accompanying the acoustic objects.

Bandoneon ! was for Tudor a substantial breakthrough: it was the first occasion in which he was fully represented as a creator in his own right. In the course of the 9 Evenings he also participated in the performance of others' works—with John Cage in his *Variations VII* and with Deborah Hay in her *Solo*—but he was at this point breaking his ties to the piano, and with the assistance of his E.A.T. collaborators, reinventing himself as composer of a unique and complex electronic music. He had also identified and tested an idea which would sustain an important stream of his work for the next decade, through four versions of *Rainforest*, to *Forest Speech*, the final version of which was performed in 1978.



Figure 2-7. Stills from videotape of *Bandoneon !* performance October 13 1966, in the series 9 Evenings: Theatre and Engineering, 69th Regiment Armory, New York City. Reproduced courtesy Experiments in Art and Technology.

Top: Tudor's performance platform, with Lowell Cross's projection screen in background. Bottom: Two of Tudor's roving loudspeaker-objects, "aluminum sheets (suspended ca. 15")", and "2 - 14' wooden planks mounted at 90°". (Tudor 1966d) The large horn at right is a conventional loudspeaker.

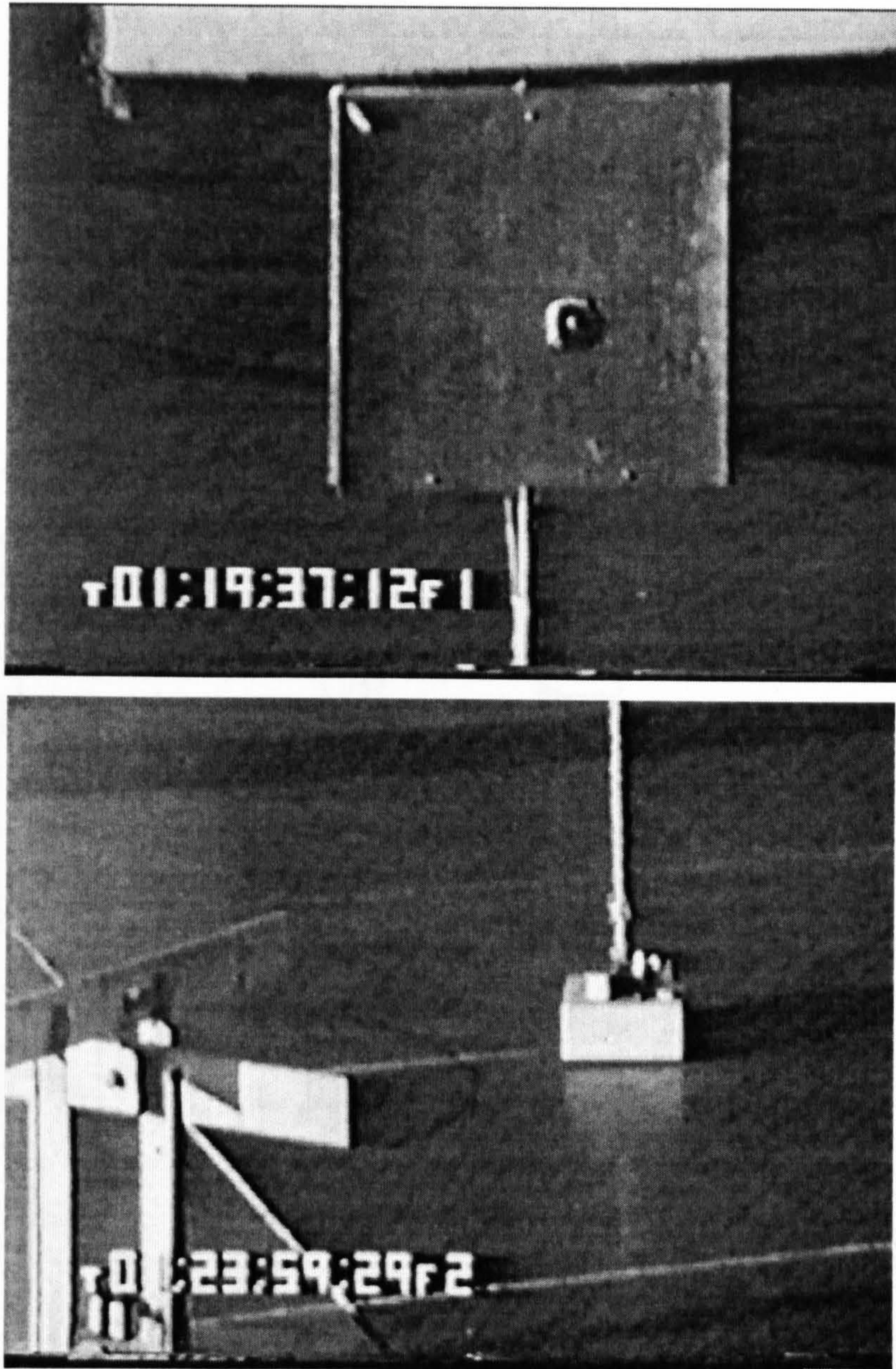

Figure 2-8. Stills from videotape of *Bandoneon!* performance October 13 1966, in the series 9 Evenings: Theatre and Engineering, 69th Regiment Armory, New York City. Reproduced courtesy Experiments in Art and Technology.

Top: Detail of "aluminum sheets (suspended ca. 15)". Bottom: Detail of "2 - 14' wooden planks mounted at 90°".(Tudor 1966d) Transducers can be seen in both stills.

Figure 2-8. David Tudor, "Bandoneon! (acoustic, controlled, digital)" (Tudor 1966d), a 1966 design for performances October 13 and 18 1966, in the series 9 Evenings: Theatre and Engineering, (reproduced) courtesy Research Library, The Getty Research Institute, Los Angeles.

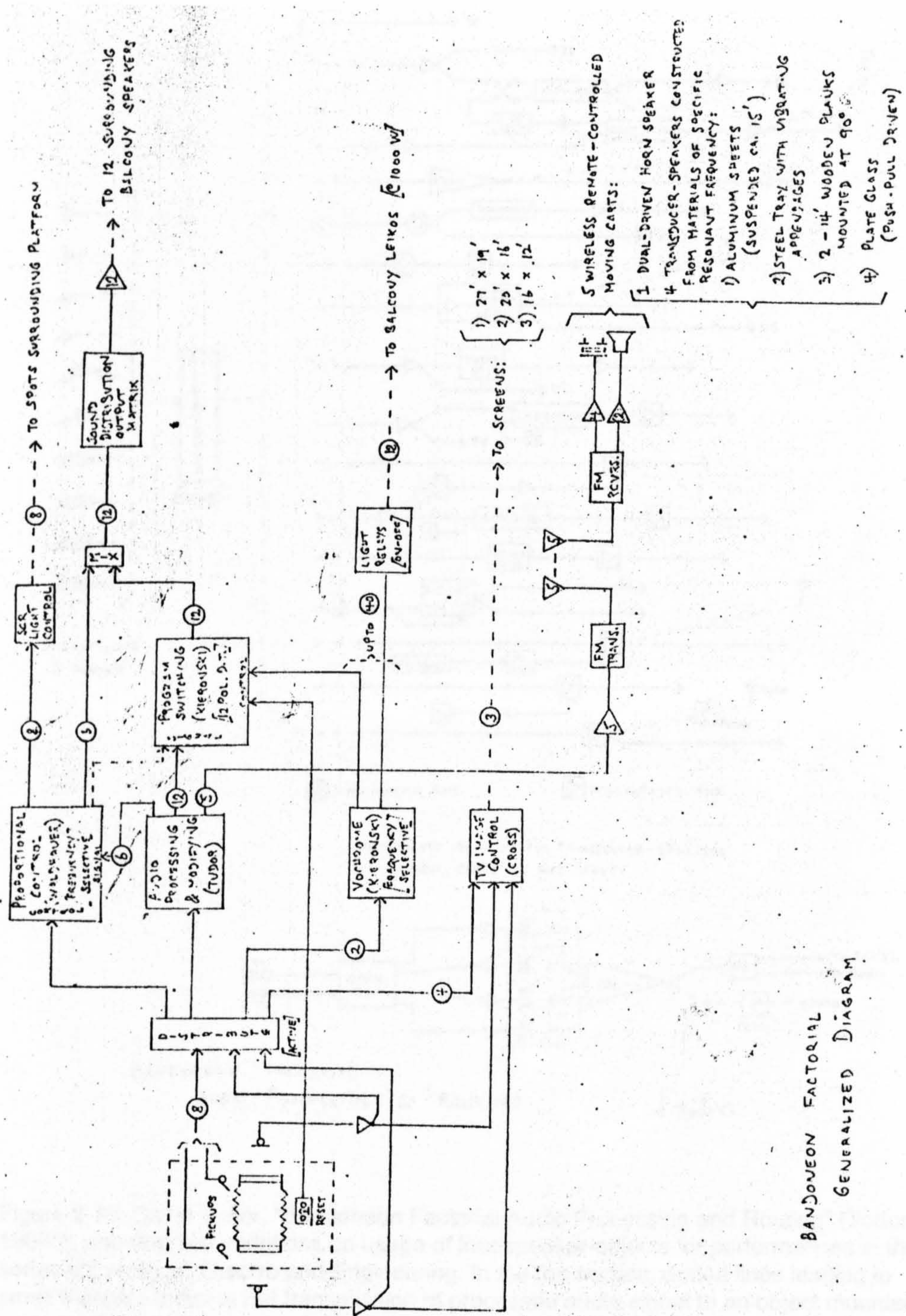

Figure 2-9. David Tudor, "Bandoneon Factorial Generalized Diagram" (Tudor 1966d), a score diagram for performances October 13 and 18 1966, in the series 9 Evenings: Theatre and Engineering. Reproduced courtesy Research Library, The Getty Research Institute, Los Angeles.

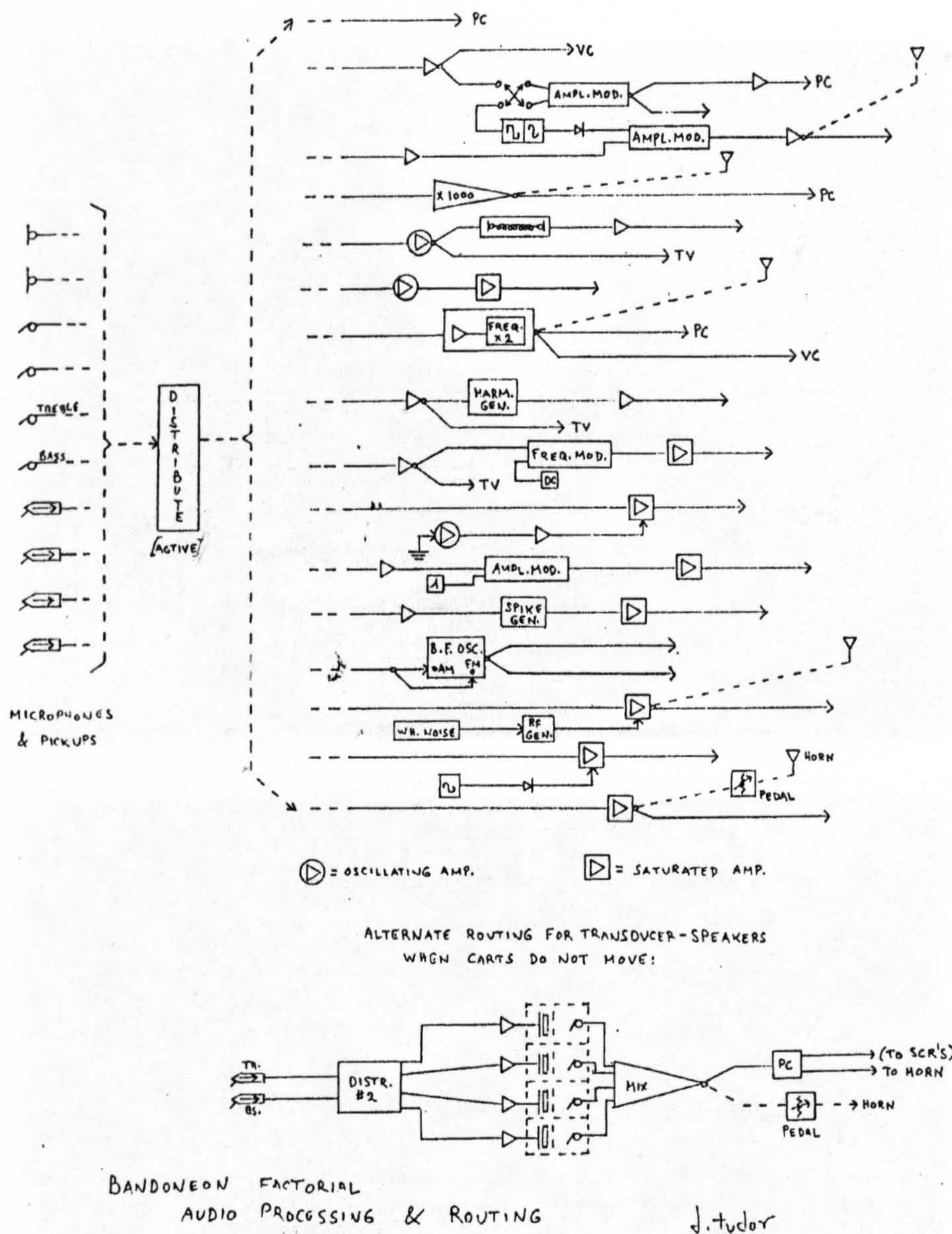

Figure 2-10. David Tudor, "Bandoneon Factorial Audio Processing and Routing" (Tudor 1966d), showing two variations on usage of loudspeaker-objects for performances in the series 9 Evenings: Theatre and Engineering. In the top section, dotted lines leading to small triangles indicate FM transmission of processed audio signal to an object mounted on a mobile cart. These were used in the October 13 performance. The lower section of the diagram shows a more basic "alternate" routing of direct bandoneon signal to objects for the October 18 performance in which the carts were not employed. In this case it is interesting to note that the sound distributed to the Armory's twelve conventional loudspeakers is sound returned from pickups attached to the loudspeaker-objects—precisely the model for Tudor's *Rainforest* series beginning in 1968. Reproduced courtesy Research Library, The Getty Research Institute, Los Angeles.

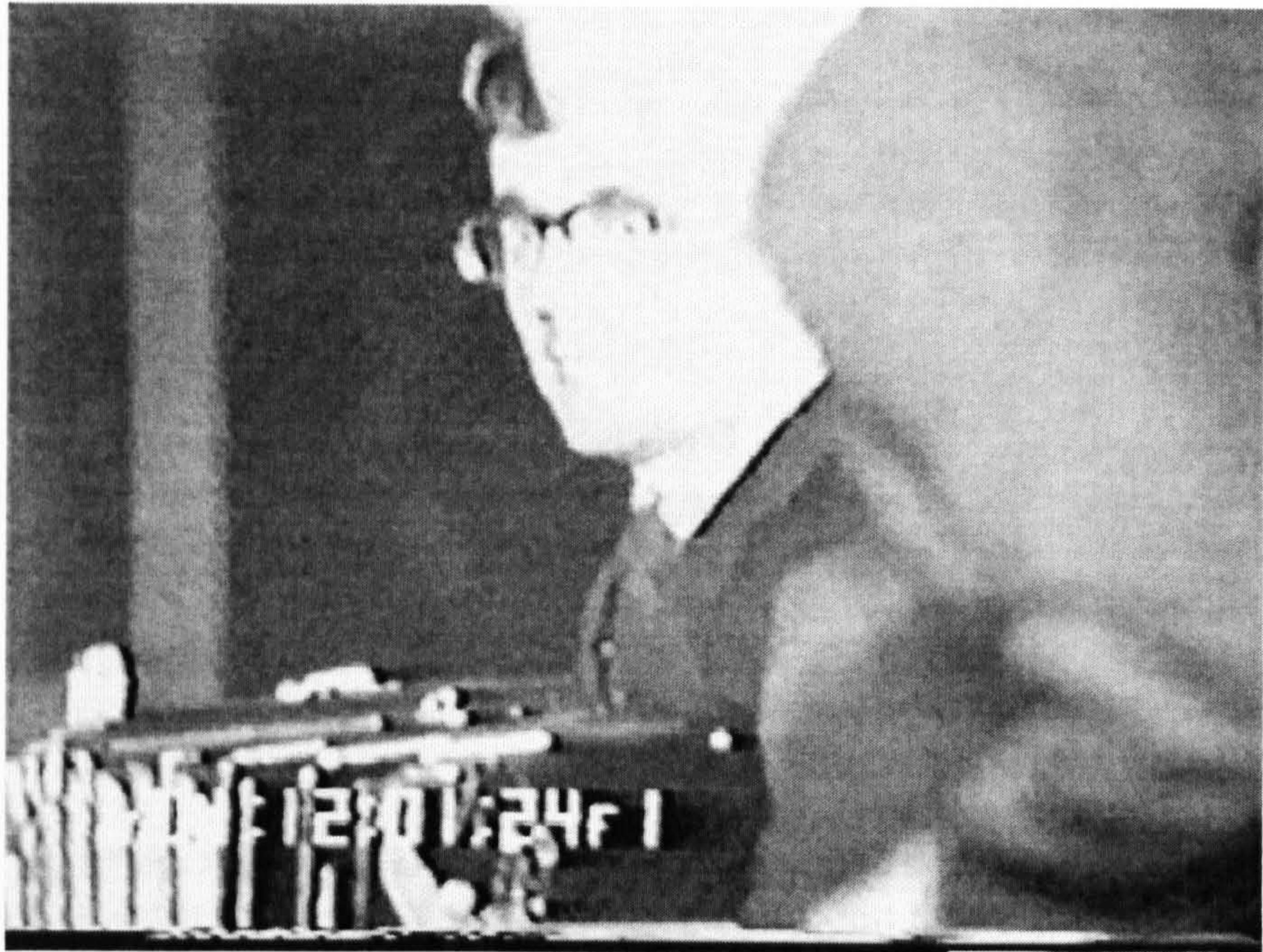

Figure 2-11. Stills from videotape of *Bandoneon!* performance October 13 1966, in the series 9 Evenings: Theatre and Engineering, 69th Regiment Armory, New York City. David Tudor with bandoneon. Reproduced courtesy Experiments in Art and Technology.

Chapter 3

ENTERING *RAINFOREST*: VERSIONS 1 (1968) AND 2 (1969-70)

After all, what is a loudspeaker? At present it's a reproducing instrument, but my feeling all along has been that you should regard it as a generating instrument. All musical instruments work by generating sound waves, and so does a loudspeaker, so if you regard it from that point of view your whole notion of how to construct one would have to change. Why shouldn't there be a thousand or more ways of building loudspeakers? [...] Every sculptured loudspeaker has certain special characteristics, so my problem becomes that of finding what sound I can put in so as to reveal the unique properties of the material.

David Tudor
(Tudor 1972c)

Tudor and Cage/Cunningham

John insisted there were no rules, everything was free. Then David would say "well, is there such a thing as too loud?" to see if John would complain. And of course John rigidly refused to complain so David would say, "How about this?" and "How about that?" You know.

[...]

There's a lovely moment, I loved this moment, it was early when Gus Solomons was with the Company. Huge, very long, very skinny black man, and he was standing with one leg *à la seconde*, meaning sideways, up in the air, and they [Tudor and other company musicians] had been tuning in the pit, and as he was doing his warmup there was this very loud sound, and so he was up like this, and it stopped instantly and he fell over [snaps fingers]. He said, "I was leaning against it!" (Emmons 2002)

Tudor's association with John Cage and Merce Cunningham was a long and important one, personally and professionally, beginning in 1950 with Cage's introduction to Tudor by choreographer Jean Erdman (Holzaepfel 1994, 25). Cage and Cunningham were already well-established both as a creative duo and as companions: Cunningham is quoted as saying he "counts his beginning" from a collaborative performance with Cage in New York in 1944 (Vaughan 1997, 7). In November 1950 Tudor appeared as a pianist for the first time with Merce Cunningham and John Cage (Vaughan 1997, 56); this was the beginning of a lifelong association with the two, during which Tudor evolved his role from pianist, to interpreter of pieces involving amplification and other electronics, finally to composer/performer of his own electronic works. Following Cage's death in 1992, he took on Cage's longtime role as Musical Director of the Merce Cunningham Dance Company.

There are strong suggestions from correspondence in Tudor's archive that his and Cage's early years together include a period during which Cage was not only enamored of his prodigious musical talents but was also deeply drawn to Tudor romantically, and was then apparently equally deeply frustrated by Tudor's reluctance to return his affections, as Tudor

began a serious new relationship with poet and potter Mary Caroline [M.C.] Richards. Cage eventually wrote to Tudor a letter giving reluctant blessings on the new relationship, stating "My own feelings towards you were always those of wishing to flow in where it looked like water was absent" (Cage undated A).

Whether Tudor and Cage's long-time partnership ever again included a romantic aspect is unknown. Tudor wrote in 1972 that "John and I have a regard for each other that transcends the other relationships" (Tudor, 1972b): what is certain is that their working relationship and mutual respect were secure, and that Cage, as the more gregarious and self-promotional of the two, from time to time gave his friend a professional boost: for instance, the duo's 1972 European concert tour featuring simultaneous performances of *Rainforest 3* and *Mureau* came about as a result of Cage's refusal to have Tudor invited along merely as an interpreter of his work (Cage 1971d). As Cage became a celebrity of sorts, while Tudor remained relatively unknown, Cage made unsuccessful efforts to encourage him to document his life and art (Cage 1984).

Early on, Cunningham and Cage had adopted a method of working independently, creating music and dance separately and then bringing them together in performance. Cage had experienced disillusion in attempting to deliberately convey "meaning" through his music. He had decided that it was better to assume that each listener would have a unique experience of the music regardless of the composer's intended programme, and he thus need not be concerned about that aspect of his compositions. Cunningham too spoke in these terms, indicated by his comment in Vaughan (1997, 44): dance was "organized movement in time and space" and "need not, indeed should not, have a literary meaning". Dance and music shared the element of time, they reasoned, and so time became the sole organizational principle of their collaborations. In 1948, Cage and Cunningham gave a lecture-demonstration in which they demonstrated their approach: deciding upon a time structure, each went off separately to create work to fill that

structure, then they performed it together. This model of "cooperative interdependency" (Cunningham quoted in Vaughan 1997, 44) was followed throughout the subsequent decades of Cage and Cunningham's work together, and Merce Cunningham and Dancers (later the Merce Cunningham Dance Company) became famous for rigorously following the aesthetic. In practical terms, this method removed the necessity for time- and labour-intensive rehearsals to coordinate composition and choreography; in professional terms, it acknowledged the equality of artforms and allowed each collaborator maximum freedom. Cage, in his collaboration with other choreographers in the 1940s in California, came to feel that his music was very much in a subservient role to the dance; performing with Cunningham was more akin to giving a musical recital simultaneously with a dance performance.

It is this distinct division of labour within the Company that suggests an analysis of its music apart from its dance is possible; not only convenient, but entirely appropriate. The remainder of this chapter deals with the beginnings of Tudor's *Rainforest* series—versions 1 and 2—within the context of the Cunningham Company, leaving aside much analysis of the dance which it accompanied.

Commissioning a *Rainforest*

As of 1968, David Tudor had significant experience with objects transformed into loudspeakers, through the attachment of special transducers; as already described, the idea was a central feature of his 1966 multi-media work *Bandoneon !*. Following that 1966 performance, however, it appears that the speaker-object concept was not immediately pursued, or further developed. Whether Tudor had any independent plans to extend his idea is not known; what he stated in an interview with John Fulleman (Tudor, 1984) is the following:

So that worked OK [the loudspeaker-objects for *Bandoneon* !], and those things [the objects] sat around and Merce Cunningham asked me for a piece. Well, I have those things lying around, so I might as well put them to use.

The piece which Merce Cunningham requested from Tudor in 1967, was an accompaniment for a new dance which according to Company musician Gordon Mumma (2001c) was then still untitled. For the commission, Tudor eventually received a \$500.00 fee and the promise of an additional \$25.00 fee per performance (Cunningham Dance Foundation 1968). The premiere of *RainForest* with *Rainforest* on March 9 1968, as part of the Second Buffalo Festival of the Arts Today, in Buffalo NY, was one of a series of performances made as the culmination of a one-month residency for the Company at the Buffalo campus of the State University of New York and Buffalo State University College. The residency was extremely productive: two major new dances were premiered during the series: not only *RainForest*, but also *Walkaround Time*, with décor by Jasper Johns (based on Marcel Duchamp's *Large Glass*) and music by David Behrman ("*...for nearly an hour...*", the title also referencing a Duchamp work) performed by Behrman, Cage, Mumma and Tudor. Tudor, for his part, was installed for most of the residency in the basement of musician Stuart Dempster, who was then a member of the Creative Associates at SUNY Buffalo; Dempster (1999, 15) recalls that Tudor "went about arranging all his tools and soldering equipment. He set to work on various circuitry, most of which was for *RainForest*. He 'blooped' and 'bleeped' all during the first week, until it was time for him to move his electronics into the performance space".

Merce Cunningham's dances are avowedly non-narrative. David Vaughan, the Cunningham Company's archivist, has written of the dance *RainForest*, however, that it falls into the category of a "nature study", and was informed both by anthropologist Colin Turnbull's book *The Forest People* as well as by Cunningham's memories of growing up in the rainforest climate of the coastal Northwestern United States (Vaughan

1997, 162-163). The title of the dance was appropriated for Tudor's music: Gordon Mumma (2001c) recalls that

David Tudor's role in the title is absolutely clear in my memory. Merce asked David to do the music. David went on with his experiments, taking the occasion to obtain the large metal sheet, and one of the cymbals (etc.) for the resonating objects in the orchestra pit. He sent me off (to Canal St. in NYC) to buy some more small transducers, including World War II throat microphones that I'd found. The stuff accumulated, and we worked together to make a setup of equipment that would be practical for touring. [...] From time to time (before the premiere in Buffalo) I asked David if he'd made a title. "No, not yet, I'm too busy with the work". When Merce finally titled the choreography as *RainForest*, David replied, "Now there's a title".

When Tudor was told the title of the new dance, Vaughan (1997, 163) records that he responded "Oh, then I'll put a lot of raindrops in it". Tudor's response may have been either ironic or mischievous: music for Cunningham Company dances is also typically non-programmatic. On the one hand, dance writer Don McDonagh (1992, 12) wrote of *RainForest*, "There is no rain to be seen or heard in the piece", but numerous other writers and reviewers have commented on the "natural" imagery evoked by both its sound and movement: of the 1988 revival of the dance, Steven Smoliar (1992, 86) wrote that "David Tudor's score is fine food for the imagination. The sounds are obtained from wooden and metal objects which resonate with acoustic vibrations, but they are easily transformed 'in the mind's ear' into a weird repertoire of bird calls and animal murmurs".

It is interesting to recall again that Experiments in Art and Technology, the organization which had commissioned Tudor's 1966 piece *Bandoneon !* which included Tudor's first use of "*Rainforest* loudspeakers", had by the end of the 1960s identified the (natural) rainforest as a metaphor and model for its mandate and working methods. E.A.T. was close to Cage, Cunningham and Tudor; Billy Klüver, the engineer from Bell Laboratories who was the driving force behind

E.A.T., had collaborated with all three on technology for Cunningham's 1965 dance (and multimedia spectacle) *Variations V*. E.A.T. was also responsible for overseeing creation of the Pepsi Pavilion at the Osaka World's Fair in 1970, which Tudor was deeply involved with, and which provided him with ideas and concrete materials which sustained his work for many years following. In a 1970 document by Klüver entitled "Rainforest", he set out the E.A.T. philosophy, explained in terms of an ecosystem:

The rainforest is made up of thousands of feedback loops of continual activity. Thousands of animals, plants and trees live in the rainforest. Its roots are few and shallow as opposed to the oak tree's deep roots in the ground. The oak tree takes energy out of the ground and shades the area so that no small bush or flower can grow near it.

The main purpose of Experiments in Art and Technology is to develop, through experimentation and experience, fluid organizational forms whose model is that of the rainforest rather than the oak tree.

(Klüver 1970)

Klüver (2002) recalled the importance of the rainforest metaphor for his late-1960s *milieu*: "the concept of the rainforest, as a self-sustaining growth, was there. I don't know who was first [...]"

Rainforest 1: from minimalist drones to expressive soundscaping

One of the things which is most interesting about Tudor's *Rainforest* for dance is that over time its sounds seem to have become an ever more diverse and naturalized soundscape of an imaginary rainforest, full of chirps and chatters generated with electronic circuits. Beverly Emmons, whose lighting design for the 1968 *RainForest* was one of her final creative tasks for the Cunningham Company (Emmons 2002), suggests

that there was "a sense from some that because the piece was named *RainForest*—Merce gets to pick the name, and that's the only thing he tells the composer—that what David cooked up was a little too one-to-one. It *sounds* like a rainforest. Well do we do that? [...] That was a bit of David's rebellion [...] I think he got off on it. He got off on seeing if he could do it".

In a later description of the piece, Tudor (1988) wrote: "The composition was implemented thru the construction of special insts. [instruments], which can be manipulated to produce sounds resembling those of nature", and in an interview in the 1980's Tudor (1984) described *Rainforest 1*'s sound sources as "oscillators that made animal-like and bird-like sounds".

It should be noted that by 1968 Tudor was already a keen field recordist of the natural world, although the sounds he recorded did not, apparently, make their way into *Rainforest 1*, which is clearly intended to be of an "electronic nature". Beverly Emmons (2002) recalls how, during the Cunningham Company's Latin American tour of 1968 (in the summer months, following the March premiere of *RainForest*), "David [Tudor] and Gordon [Mumma] got arrested crawling around in the bushes [in Rio de Janeiro] at four o'clock in the morning outside the hotel, trying to get bug noises, because the bug noises down there are just great!"

Gordon Mumma (2001d) offered another 1968 recollection, of the importance of these field recordings in the *Assemblage* project for KQED television in San Francisco, a collaboration with the Cunningham Company and musicians Cage, Mumma and Tudor:

John suggested that we make considerable use of "existing sounds of the world environment". The three of us did this, each in different ways. [...] John got recordings of thunderstorms from Brazil, etc. [...] David used, among other things, some of his growing collections of insect sounds, that he continually processed. [...] I gathered sounds from around San Francisco.

A 1970 anecdote from Jean Rigg (1970) illuminates further the connections (or the boundaries) between the analog and electronic in *Rainforest 1*. At that time, Tudor was not touring with the Cunningham Company; he was in Japan working on the Pepsi Pavilion at Expo 1970 in Osaka. Rigg wrote to him:

[...] we got to the aviary in Pittsburgh, Gordon w/ tape recorder, and John [Cage], who's a bit out of sorts because you "stole" the *Rainforest* "birds", and I got in to an amusingly heated battle over whether or not Gordon's aviary recordings belonged in that night's performance of *Rainforest*. Well, I don't know what was amusing about it except maybe to find myself in heated battle with John in the first place. Anyway, it was finally agreed that the recordings were, to use David Behrman's tactful description, "too literal". Actually, the heated battle began in Amherst over John's and my disagreement over the definitions of 'steal' and 'birds'.

The "birds" which Tudor had apparently taken with him to Japan, were not actual field recordings of birds, but recordings of "birdlike" electronic sounds, according to Gordon Mumma (2001d); to replace them with recordings of real birds was judged to be against the "electronic nature" of *Rainforest 1*.

Although the music for Cunningham's *RainForest* eventually came to admit field recordings (of electronic sounds) in addition to signals generated "on the spot", and although the piece came to suggest "the chattering and crying of birds and animals" (Vaughan 1997, 163), in its first performance in 1968 it was austere and minimal in character, and could hardly be described as evoking such sonic images: it consisted primarily of long sustained tones, bringing to mind the drones which La Monte Young was then already using to create static sound sculptures.

The qualities of the first performance are a direct "fit" with Tudor's directive for performing *Rainforest 1* which is as follows (and as seen in Figure 3-2): "Use only signal generators, any kind, as inputs. At least

eight will be required. Vary the waveforms. (Note that simpler waveforms generally produce more complex results)" (Tudor 1968). Combined with Tudor's 1968 block diagram for *Rainforest* (Figure 3-1), this directive constitutes the only "score" for the piece.

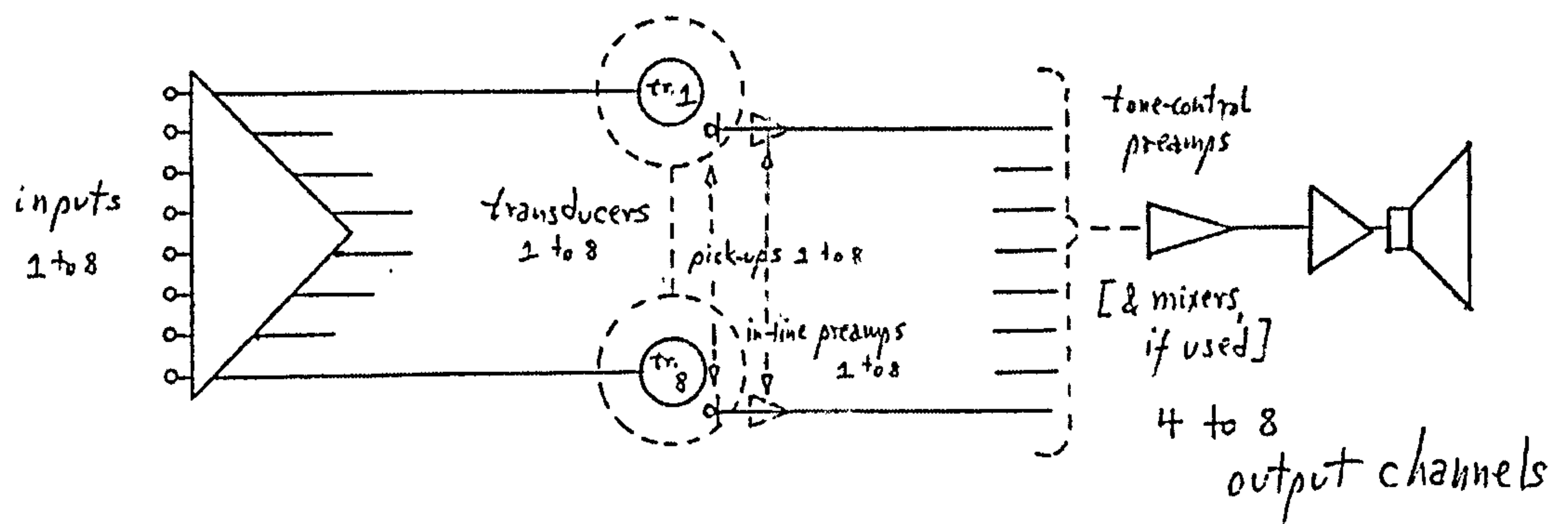

Rainforest 1968
 block diagram
 d. tudor

Figure 3-1. Block diagram for *Rainforest 1* (1968) (Tudor 1968a) showing use of eight-channel amplifier with outputs to eight transduced objects; pickups (phonograph cartridges) return the sounds of each resonating object to a conventional sound system of between four and eight channels. Reproduced courtesy the Estate of David Tudor.

RAINFOREST

Eight instrumental loudspeakers, sculpturally constructed from materials having different resonating characteristics. Signals sent to these instruments, through appropriate transducers, will be effectively modulated in a physical sense.

The resulting sounds can then be sent, via pick-ups placed on the instruments themselves, to an output sound system, having at least four channels. (See diagram).

Any number of performers, whose action should be to discover (in real time) and disclose the resonating points of the different instruments.

The relation of the inputs to the channels of the output sound system can be stationary or switched at will.

Options:

1. Use only signal generators, any kind, as inputs. At least eight will be required. Vary the waveforms. (Note that simpler waveforms generally produce more complex results).
2. One (speaking) voice only as input; the instruments acting as filters. The outputs can be mixed down to two for this version.
3. As (2.) but with up to eight voices, singing or speaking. Four to eight output channels.
4. Various taped materials used as input. Limit these to two at any given time, distributed among the eight channels.
5. In a small space Rainforest can be performed using the instruments alone, without an auxiliary sound system.

The most sensitive control point is always the gain into the transducers.

David Tudor

March 1968

Figure 3-2. List of performance options for Rainforest (Tudor 1968), dated March 1968 but more likely drawn up 1972 or later (since options 2 to 4 refer to versions performed between 1969 and 1972). Option 1 corresponds to *Rainforest 1* (1968); option 2 and 3 to *Rainforest 2* (1969-71); option 4 to *Rainforest 3* (1972). Option 5 does not describe a distinct version but is rather a performance suggestion for any of the versions described in the list of options. *Rainforest 4*, the large installation version, is not explicitly mentioned in this document but the reference to "Any number of performers" strongly suggests it, since all earlier versions of Rainforest were presented as either solo or duo performances. Reproduced courtesy the Estate of David Tudor.

The block diagram in Figure 3-1 clearly describes the technical setup: eight inputs, from various unspecified signal generators, which pass through an amplification stage before reaching eight transducers attached to eight objects; then, a second level of sound production in which the sound of the resonating objects is brought back via eight pickups (phonograph cartridges) through preamplifiers and/or mixers which offer basic control over timbre; and finally, a conventional PA system of between four and eight channels, through which the sound of the resonating objects would be heard (Gordon Mumma has stated that in the first few years of performing the piece, the actual number of resonant objects employed was "rarely more than three [...] all for practical reasons in the cramped orchestra-pit contexts of touring" (Mumma 2006b)). For an audience witnessing Merce Cunningham's dance *RainForest*, this "reflection" from the resonating objects would have been its primary experience of *Rainforest 1*, since the objects were located with Tudor and the other musicians, often in the orchestra pit, where their unamplified sounds would not have carried far.

Rainforest 1 as a theme with variations

In addition to Figure 3-1 which describes the technical setup, the *Rainforest* performance options list in Figure 3-2 sets out that this version of the piece is defined by use of signal generators as sound sources. Additional information about performance practice, obtained through interviews, is extremely useful, however, as it elaborates and extends Tudor's performance options for this version of the piece. The fact that *Rainforest 1* actually had (and has) rather variable performance parameters in practice, highlights the reality that the numbered versions of *Rainforest* are points along a continuum: everything subject to contingency and/or ongoing experimentation. That the variability of performance practice is really only recoverable through oral history makes clear that efforts to construct "correct" performances of *Rainforest*

1, which might be attempted through a strict reading of Tudor's written "score materials", may be misleading.

For instance, one very important aspect of *Rainforest 1*, which is not documented in Tudor's list (Figure 3-2), is that the piece was conceived as a double performance: Gordon Mumma (1975, 69) writes that "Tudor's music for *Rainforest* was a collaborative duo between him and myself, performing with a forest of electro-acoustic transducers of his own uncanny design". The piece was distinctly Tudor's conception, however, and Mumma (1975, 72) states that he "lost sleep over the prospect of Tudor's not setting up his own electronic menagerie".

The first performance was given by Tudor and Mumma, and the duo subsequently performed the piece on many occasions: between 1968 and 1973 the dance was presented by the Cunningham Company in more than 70 performances in ten countries as far afield as Poland and Brazil. Tudor and Mumma also made duo concert performances of *Rainforest 1* on occasion. Mumma (2001d) recalls that each player was in control of at least four objects, and that "sometimes there was an overlap into the mixer setup, so that we would adjust each other's levels, EQ, recycling, or even source distribution". His description for their combined performance is "piano-four-hands" style:

[...] when we performed together we always left room for what the other was doing. Lots of room! After the first two performances, I was surprised to see how often David just sat aside, not doing anything except perhaps a level adjustment. He would listen carefully, sometimes taking notes (when there was enough light), and then re-enter so that we were working together, or I might "step aside", in particular when David got lots of sound going (Mumma 2001d).

The possibility existed that the piece could also be performed as a solo, as contingency directed: Mumma (2001d) says: "[...] there were performances in which only one performer did it all, sometimes only

David (when I was away) and sometimes only me (when David was away). In those occasions the sounding materials of *Rainforest [1]* were somewhat simpler, but not dramatically so [...]. *Rainforest 1* was never performed by more than two musicians, however.

Regarding flexibility of sound sources, Mumma (2001d) says: "David's early versions were entirely of electronic sources -- that's what we did for the first year or two (1968-69)". This means hardware oscillators of one type or another; judging from photographs, this included several examples of commercially-available tone generators which would have had a selectable range of waveforms and frequencies. But the equipment for the piece also included a number of handbuilt or custom-modified devices, as Mumma (2001d) explains:

[...] from the 1968 *Rainforest* premiere and onward, the oscillators David used were cousins to the modulation devices I developed for my own [compositions]. There were several types of modulation that I had developed: frequency-modulation, amplitude-modulation, and envelope-modulation. [...] What I did, and what David used in the early *Rainforest*, was to use the "carrier" function of the modulators as "variable" waveforms [...] As he became more skilled with his own electronic design and building, he modified the designs of the devices I built for him, and he designed/built his own.

We have already seen that performances of *Rainforest 1* eventually came to admit of prerecorded sound sources in addition to the tone generators which were exclusively used "for the first year or two". Practicality was again the agent of change in the introduction of alternatives, which seem to have primarily been adopted in order that *Rainforest 1* could still be satisfactorily performed when Tudor or Mumma or both were unavailable; Mumma was at that time performing frequently with the Sonic Arts Union (with Alvin Lucier, Robert Ashley and fellow Cunningham musician David Behrman) and Tudor also frequently took on other projects, significantly with E.A.T. in the role of advisor/designer on the 1970 Pepsi Pavilion project. "There were occasions when I wasn't in a particular performance", Mumma (2001d) says:

[...] and the few times that John [Cage] would "sit in" for me, it wasn't always what David wanted, because John didn't know how all the *Rainforest* equipment worked together. I did, of course, because I was with David right from his beginning work on it—his clever arrangements of diverse electronic equipment. So, David began to develop recorded "electronic sources" to substitute for the standard and "specially designed" oscillators (some of which he made, some of which I made for him). That simplified the performing of *Rainforest* on "short-staffed" tours.

It seems that the prerecorded sources (such as the "birds" mentioned earlier) were primarily the solution to a personnel problem, rather than an experimental next step: John Cage had passed through a phase of enthusiasm for experimental electronic music and new media in the mid-1960s, and had emerged on the other side, edging back towards notated works for acoustic instruments. It appears that Tudor felt Cage could not, or perhaps simply did not want to, perform *Rainforest 1* live using his (Tudor's) collection of sound generators. Tudor's solution, rather than having Cage employ simple tone generators which he would have been quite comfortable using (from past experience in his own live performances), or having him develop his own alternative approach to the piece, was to provide recordings of himself playing his own oscillator circuits.

This step had the effect of maintaining a specific soundworld for the piece: Tudor could be sonically present even when he had to be physically elsewhere; clearly, too, it was still important to Tudor that the piece be performed by two musicians, even when one was manipulating taped sources rather than playing the circuitry. The anecdote about the "birds" related by Jean Rigg reveals the depth of the problems which might arise if Tudor took his tapes with him.

Gordon Mumma (2001d) recalls that Tudor's prerecorded sounds for *Rainforest 1* were made on cassette tapes—a fairly new technology at the time—and that "taped sounds included both 'birdlike' sounds, and

perhaps sounds that he had recorded from some of our performances [... via] transducers attached to resonating objects". This latter technique has the character of a feedback loop, in which the resonance of an object can be enhanced by taking its output back to its input, although the process Mumma describes is not realtime in the sense of having a live, open-circuit feedback loop in operation.

Interestingly, Tudor mentions use of such a realtime process in the context of Cunningham *Events*, performances in which fragments of various dances are collaged together, with unspecified musical accompaniment: an ideal workspace in which to experiment with new ideas: "I did experiment several times, for Merce's 'Events'... where I did feedback into the system. But that isn't so interesting when the output is so small; it gets very interesting when they're larger" (Tudor 1984). This system of feedback is akin to the process illustrated in Alvin Lucier's 1969 *I am sitting in a room*, which recycles a spoken-word recording again and again within a room, letting its resonant frequencies become predominant: Lucier's piece might be described as falling between Tudor's "live" feedback experiments and his use of recorded resonating objects for use as input signals on other occasions.

It is worth noting here that the total presence of the resonating object, as experienced by the audience at a performance of Merce Cunningham's *RainForest*, is partly defined by the types of transducers and pickups used. The resonance of the object is central to the character of the sound, but it is coloured to a great extent by the frequency response of the weighty transducer, as well as the location on the surface of the object to which the transducer is attached. The frequency response of the pickup used to "reveal" the object resonances to the audience, is then very important as well; the phonograph cartridges originally used have their own resonances to take into account, and more contemporary realizations have used piezo disc pickups which, while inexpensive and easy to find, are even less linear in their frequency response.

Tudor, in an interview with Chadabe (1993), said: "You put the sound through a physical material, so that the physical material transforms the original source which is fed into it, and if you can manage to amplify that sound with a microphone, you release the harmonic content which the material gives to it". The "material", however, includes the microphone itself, which makes it clear why "tone-control preamps" as shown on Tudor's *Rainforest 1* diagram in Figure 3-1 would be so useful: they are placed in the circuit following the object pickups, and thus can be adjusted to compensate to some degree for nonlinearity of the pickups. Of course nonlinearity was the goal, so any irregularities in the pickups might have been something to be exploited rather than avoided. Tudor (1989) said, of working with his *Rainforest* objects:

[...] those are real physical instruments. [...] They have personalities, that only I see, because of my use of them. It's an act of discovery. I try to find out what's there and not to make it do what I want but to, you know, release what's there.

Tudor's use of the metaphor of the "release" of sound is an interesting one; Western musicians do not often describe their role as coaxing their instruments to "release" music. It recalls the influential words of filmmaker Oskar Fischinger to a young John Cage, which resonate through *Cartridge Music*: "everything in the world has a spirit which is released by its sound" (Cage quoted in Hines 1994, 91). In Rudolf Steiner's Anthroposophy, worldly music is thought to be a faint resonance of cosmic musics of higher planes; Steiner (1906, chpt. 1) writes: "In music, man feels the echoes of the element that weaves and lives in the innermost core of things, which is so closely related to him". Tudor's image of "releasing" the object's sound appears to be connected to an understanding of unheard music which inhabits the object, awaiting its revelation to the enlightened listener.

Rainforest 1: Technology and Objects

Found in an early Cunningham Company contract for performances of the dance *RainForest* is the following rider, which serves to illustrate the growing fortunes of the Company at the time:

(4) Music: Basic sound system, plus two additional hours of set up and an hour of strike and packing time. The placement in the pit of eight custom-built speakers requires approximately ten square feet of space additional to the one hundred square feet normally requested (Cunningham Dance Foundation 1969a).

Not mentioned in the rider is the Cunningham Company's increasing dedication around this time to improving the audience's experience of sound through a multi-channel touring system which according to Jean Rigg (2002) was purchased at the urging of Gordon Mumma:

[...] the process of putting together what became the environment for *Rainforest* within the company was really not only David as a composer, but Gordon as a third musician [along with John Cage] and sort of resident technician putting together all of the stuff. And that came about really because Gordon had made the music for *Place* the year before and had seen what was lacking and what needed to be added. So, we acquired four speakers and whatever goes with them and began traveling with them.

[...] Buffalo was a wonderful month long residency. And I think it was during that that Gordon was putting together the sound system and David was finishing up that version of *Rainforest*. And it was given its first performance there.

It is also worth noting that by this time the Cunningham Company numbered nine dancers (including Cunningham himself), plus three musicians (which was sometimes a quartet with the addition of David Behrman); the Company had achieved a level of prominence and notoriety which allowed Cunningham to make both complex works and demands which would have been impossible just a few years earlier.

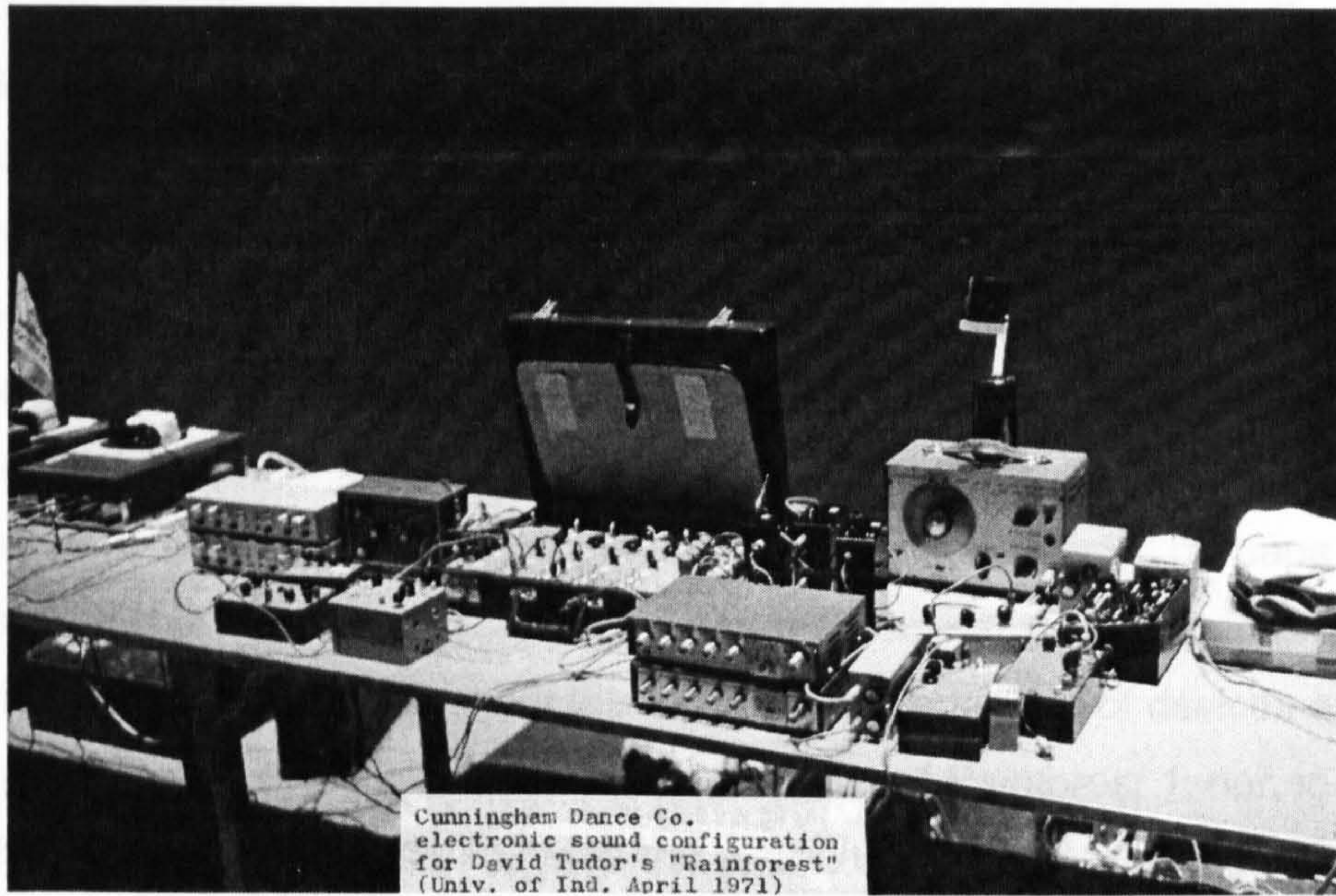

Figure 3-3. A roomy 1971 setup for *Rainforest 1*. In the top photograph, two "conventional" signal generators can be seen along with a number of custom-built devices surrounding the eight-channel briefcase amplifier. Transducers can be seen attached to objects (metal sheet, cymbal, and "one of Tudor's glass-enclosed resonating devices of the time" (Mumma 2006a)) in the background of the second photograph. Photographs by Gordon Mumma.

A seemingly luxurious amount of room for the musicians is shown in Gordon Mumma's 1971 photographs of a setup for a performance of *Rainforest 1* (Figure 3-3). Visible are two conventional commercial tone generators, and a large number of "black-box" type devices, some of which are identifiable from amongst the more than 400 items which make up Tudor's instrument collection housed at Wesleyan University. At least two loudspeaker-objects are also clearly visible (a cymbal, a metal sheet) in one of the photographs, as well as a reel-to-reel tape recorder which may have been a means of documenting the performance, or perhaps played a role in a different piece performed on the same programme. This setup likely does not represent the "original" configuration of devices and objects used in the minimalist first performance of *Rainforest 1*; nor, in light of Mumma's comments about the ever-changing nature of Tudor's setups, could an isolated example of a single performance be considered a guide to an "authentic" setup.

Without becoming overly concerned with establishing precise details of Tudor's practice in performing *Rainforest 1*, since an obsessively historical recreation of the piece seems neither possible nor appropriate, it does however seem useful to attempt a brief look at some of the equipment and tactics which seem to have defined the sound of *Rainforest 1* during the first several years of its performance. As a guide, we can use several resources:

- Tudor's descriptions of the piece, as given in interviews and as written for inclusion in performance programmes
- recordings of performances of *Rainforest 1* with and without the Cunningham dance *RainForest*, from 1968-1972
- fragmentary notes towards realizations of *Rainforest 1* as found in Tudor's archive
- items in Tudor's instrument collection which represent parts of the original setup(s) for *Rainforest 1* as described in equipment lists and as shown in Mumma's photographs.

These resources will be addressed sequentially.

Tudor's descriptions of *Rainforest 1*

As has already been noted, Tudor's own descriptions of the piece begin with the idea that less is more: "simpler waveforms generally produce more complex results" (see Figure 3-2). Judging from performance documentation, the first *Rainforest 1* was subdued and minimalist in character. But of five high-quality recordings obtained documenting subsequent *Rainforest 1* performances between 1968 and 1972, none exhibit quite the austere, sustained minimalism of the premiere performance. If we consider four other descriptions Tudor provided of *Rainforest 1*, a fuller picture emerges of its soundworld.

My RF, in its original version (1968), is a collection of small Ispkrs, sculpturally constructed from physical materials having different resonant characteristics. These instruments, each having a different 'voice', establish a means of sound transformation without electronics: the source sounds, when transmitted thru the physical materials, are modified by their resonant nodes. The source sounds used are performed live, with sound generators specially made to produce unpredictable oscillations (Tudor 1988a).

If you take a very complex result, it would become very predictable, but if you take something rather simple, then in the end the sound in the output becomes astonishing. It's like a revelation. In order to make those generators I experimented with feedback amplifiers that were capable of unpredictable oscillations (Tudor 1988b).

[in] the first [version] I had used oscillators that made animal like and bird like sounds (Tudor 1984).

an assemblage of electric transducing instruments which alter any input signals according to the different resonating characteristics of various physical materials.

The work is open at both input and output.

Its 1st version (68), used specially constructed signal generators as input, with eight instruments (Tudor [undated C]).

The first quotation is excerpted from the draft of a program note for the first major Cunningham revival of the dance *RainForest*, in 1988; the second quotation is from an interview conducted in the same year. Both contain references to "unpredictable oscillations" as a defining feature of

the piece. This is supported and further fleshed out by the third quotation, from a 1984 interview, which plainly describes the character of the "unpredictable oscillations" as connected to the world of animal soundmaking. And finally in the fourth quotation, from a draft program note, the performance of the piece being reliant on "specially constructed" signal generators is set out, making clear that generic commercial test-tone generators capable of producing only sustained waveforms at a given frequency are not the piece's defining character.

Yet "the piece is open at both input and output", an "open structure" composition of the type defined by Thomas DeLio (1984, 2), and thus admits a wide range of signal inputs which *include* the static, unchanging outputs of commercial oscillators. Indeed, all recordings of *Rainforest 1* performances, which I have had access to, include this type of signal as an element equal in importance to the more active signals produced by Tudor's "specially constructed" devices. Sustained, static drones often provide a "pedal tone" over which other, more quickly changing sounds are performed.

Little in Tudor's interviews or text descriptions of means for performing *Rainforest 1* suggest what the piece ought to sound like, as it evolves over time; for that, we are fortunate to have numerous recorded examples which give a fuller picture of performance style.

Learning from recordings of *Rainforest 1* performances

A videotape, with sound, of the premiere performance of the dance *RainForest*, was obtained from the Cunningham Dance Foundation (RainForest 1968). Five additional audio recordings of *Rainforest 1* with dance, made between 1968 and 1972, were obtained from David Tudor's collection. A concert performance recording from 1970 was also found with Tudor's collection. Dates and timings of the recordings (copies

obtained from Tudor's collection before its acquisition by the Getty Research Institute) are as follows, presented in chronological order:

1. *Rainforest 1* with dance *RainForest*, premiere performance March 9 1968, New York State University College at Buffalo, NY (19:30)
2. *Rainforest 1* with dance *RainForest*, undated ("Red Seal" box, circa 1969) (19:45)
3. *Rainforest 1* with dance *RainForest*, undated ("Hi Fi" box, circa 1969) (19:58)
4. *Rainforest 1* with dance *RainForest*, performance March 11 1970, Brooklyn Academy of Music, NY (20:26)
5. *Rainforest 1*, concert performance November 12 1970, Cornell University, Ithaca NY (42:34)
6. *Rainforest 1* with dance *RainForest*, performance August 2 1972, Brooklyn Academy of Music, NY (22:39)

These documents provide some basis for constructing a composite picture of performance strategies for *Rainforest 1*, in the first few years of its presentation. Excerpts of these recordings are included on the accompanying audio CD.

Based on careful audition of the recordings, the sonic resources for *Rainforest 1* can be divided into four groups:

- steady-state sounds (sine and square wave oscillators, audio rate pulse generators, white/pink noise sources)
- "knocking" and "tapping" sub-audio rate pulse generators
- "whoops", "chirps" and "chatters": animal- or bird-like sounds, created with feedback oscillators constructed from small amplifiers
- "machine-like" sounds which might also be described in terms of "idling motors", "squeaky hinges", "whines", "shrieks", also created with feedback oscillators; although these often have a "mechanical" quality, they frequently cross over into the previous "animal" category

Although familiar elements are heard from performance to performance, there is little consistency in how these elements are deployed. David Tudor is known to have had time strategies for performances of other of his works, both as a solo musician and when performing with other of

Cunningham's dances. *Dialects* (1984), for instance, uses a precisely timed backing tape, and for the most recent version of *Toneburst* (first version realized 1974, most recent version 1994), Tudor discussed with me the approximately-timed use of specific recordings and EQ settings (personal communication, April 1995).

In this sample of *Rainforest 1* recordings, however, no two seem to show any specific similarity in structure, beyond a general tendency to begin with simple elements and build ever more complex layers of sound over time. Most recordings begin with simple drones; the premiere performance, as already noted, depends entirely on drones throughout, with only the addition of some quiet "twittering" sounds in the second half of the performance, and a low frequency throbbing towards the end. Other recordings begin with active "chirping", or a "rattling" created by a pulse wave close to audio rate. Once a performance has begun, sound is continuous throughout; although sounds come and go, and occasionally "resolve" for a quiet minute or two, there is never a point at which all sounds cease. The entrance and exit of sounds from the four categories are improvisational, and unpredictable; part of Tudor's performance practice, as heard throughout his electronic work, is the sudden, surprising appearance of a new sound, distinctly sounding over other continuous layers. This tactic is heard again and again in all *Rainforest 1* recordings apart from the premiere, which contains little in the way of sudden surprises.

In the performances with dance, *Rainforest 1* begins quietly, and a "conclusion" is unnecessary; the music stops abruptly when the dance finishes, becoming subsumed by audience applause. In contrast, the sole concert performance among these examples begins suddenly with a loud, repetitive sound in the "machine-like" category, literally interrupting pre-performance audience conversation, and concludes with a long delicate fade-out quite different from the dance versions which tend to end with a great density and intensity of sound layers.

The pacing of all performances is similar, however; sounds enter and leave the mix frequently, with a change of "scenery" at least once a minute. Sounds which enter often remain for several minutes, but sometimes appear for as little as a few seconds or linger for as long as seven minutes. Steady-state oscillators at various frequencies, combined with typically low-frequency repetitive "machine sounds", define a ground, which changes slowly, over which a more quickly-changing soundscape of chirps, chatters and taps is constructed. Of the longest-lasting sounds, the undated "Hi-Fi" box recording has "chirpy" electronic feedback which runs for about four minutes (between approximately 10:40 and 15:00); the 1972 Brooklyn Academy of Music recording has a sound which recalls a hand saw, appearing twice for a total of about nine minutes (from approximately 4:27-8:30 and again from 9:35-14:05); the same recording features the longest continuously-lasting sound of any of the six documents—the seven-minute appearance of an extremely low-frequency pulse generator, which produces a single pulse (like a knocking sound) about once every eight seconds (between approximately 1:35 and 8:30). This "knocking" is accompanied for about five minutes (from 2:05 to 7:50) by a repetitive, high-pitched squeal: one of the few times that a sound seems almost to wear out its welcome.

Durations of the performances with dance are, predictably, similar. The recordings vary between 19:30 for the premiere, to 22:39, for the 1972 performance; Cunningham's dances are known to be tightly choreographed and usually vary by only a few seconds from performance to performance. The sole concert performance recording of *Rainforest 1*, on the other hand, is roughly twice as long as any of the other recordings; no curtain falls to cut it off.

Tudor's *Rainforest 1* notes

One might hope that David Tudor would have left a large collection of organized notes on *Rainforest 1*, to shed light on his approach to the piece and its technological and performative aspects. Instead his archive, as housed at the Getty Research Institute in Los Angeles, is a rich, suggestive trove of mostly undated notes, and confirmed identification of items which might relate specifically to the earliest version of *Rainforest* is often impossible.

Some notes can be assumed to date to certain windows of time, based on their apparent age, or proximity to other datable items, but for the most part any fragmentary notes which exist relating to the *Rainforest* series are tantalizing but cryptic, and while fascinating in themselves, and suggestive of Tudor's working processes, do not reveal any "secrets" of the piece or its performance.

Attached to Tudor's original eight-channel amplifier built into a briefcase (Figure 3-4) are two slips of paper, however, which are a key of sorts to deciphering the soundworld of *Rainforest 1*: no insight can be gleaned here into the sound-making part of the piece, but a great deal can be learned about sound-modifying. The use of objects as "acoustic filters" is at the core of the piece, and there are many hints in these two simple notes as to strategies for object selection. The two notes are simply a list of items to be attached to transducers connected to the eight output channels of the briefcase amplifier (Figure 3-5). These two lists can be cross-referenced with a detailed 1969 list of items held by the Cunningham Company for performance of dances in repertory, which includes a substantial amount of electronic equipment as well as many of Tudor's *Rainforest 1* loudspeaker-objects (Cunningham Dance Foundation 1969b).



Figure 3-4. Eight channels of low-power amplification built into a briefcase, for performances of *Rainforest 1* with the Merce Cunningham Dance Company, circa 1968-1971. This briefcase is seen in the 1971 *Rainforest* setup in Figure 3-3. Photograph by Matt Rogalsky, 2001.

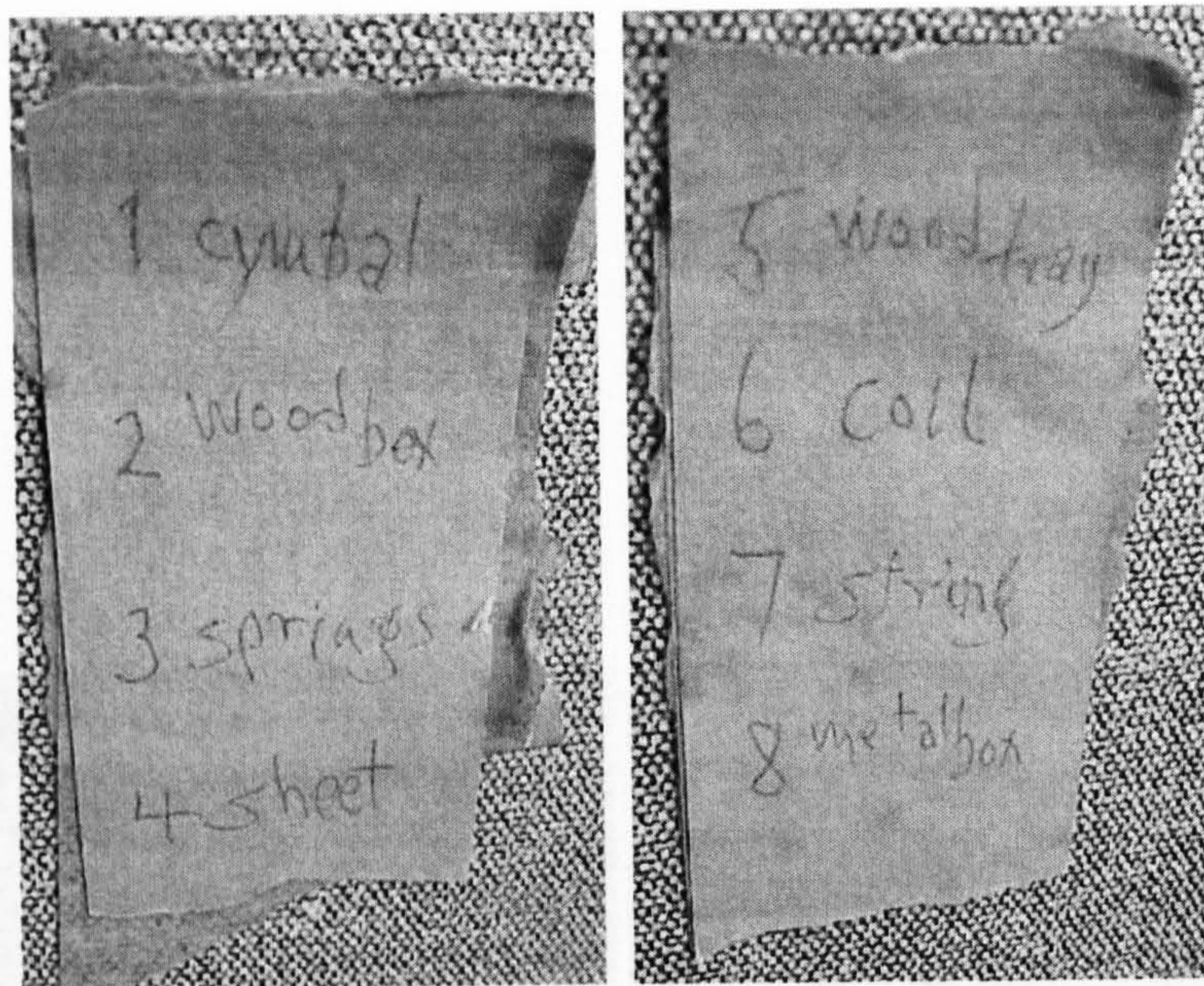

Figure 3-5. Lists naming objects to be transduced, attached to the eight-channel "briefcase amplifier". The lists are also seen in the 1971 photographs in Figure 3-3. The briefcase and some of these original objects are part of the World Instrument Collection at Wesleyan University. Photographs by Matt Rogalsky, 2001.

Tudor once described in an interview (Tudor 1994) the qualities of various materials which made objects more or less desirable for use with *Rainforest* transducers:

[...] different materials will react differently. Anything solid like metal [is good] [...] plastic is hopeless, it's too absorptive [...] wood can be quite interesting but wood is an instance where the power available to the transducers can be very important.

The items named in the briefcase amplifier lists bear out these comments: we can look at them individually in order to get a sense of how the soundworld of *Rainforest 1* is created through choice of loudspeaker-objects.

Immediately apparent and readily understandable are the items explicitly identified by materials: two wooden items, a "wood box" and a "wood tray"; and two items which are clearly metallic, a "metal box" and a

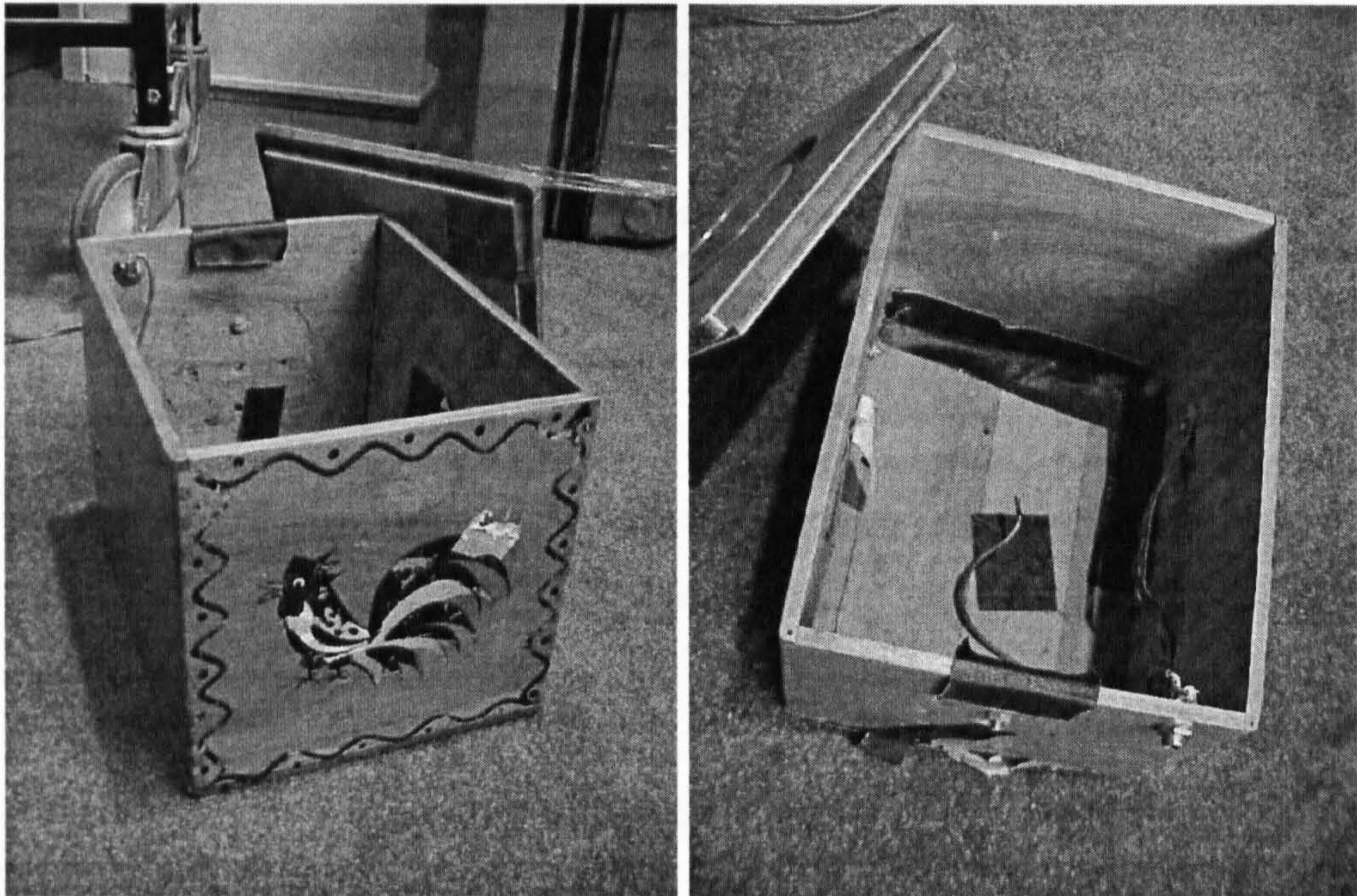

Figure 3-6. "Wooden box" included on list taped inside eight-channel briefcase amplifier. As with the "metal box", there is a mounting for a contact microphone (phonograph cartridge, now missing) to be fixed inside, with an output jack for connecting to a sound system. Photographs by Matt Rogalsky, 2001.

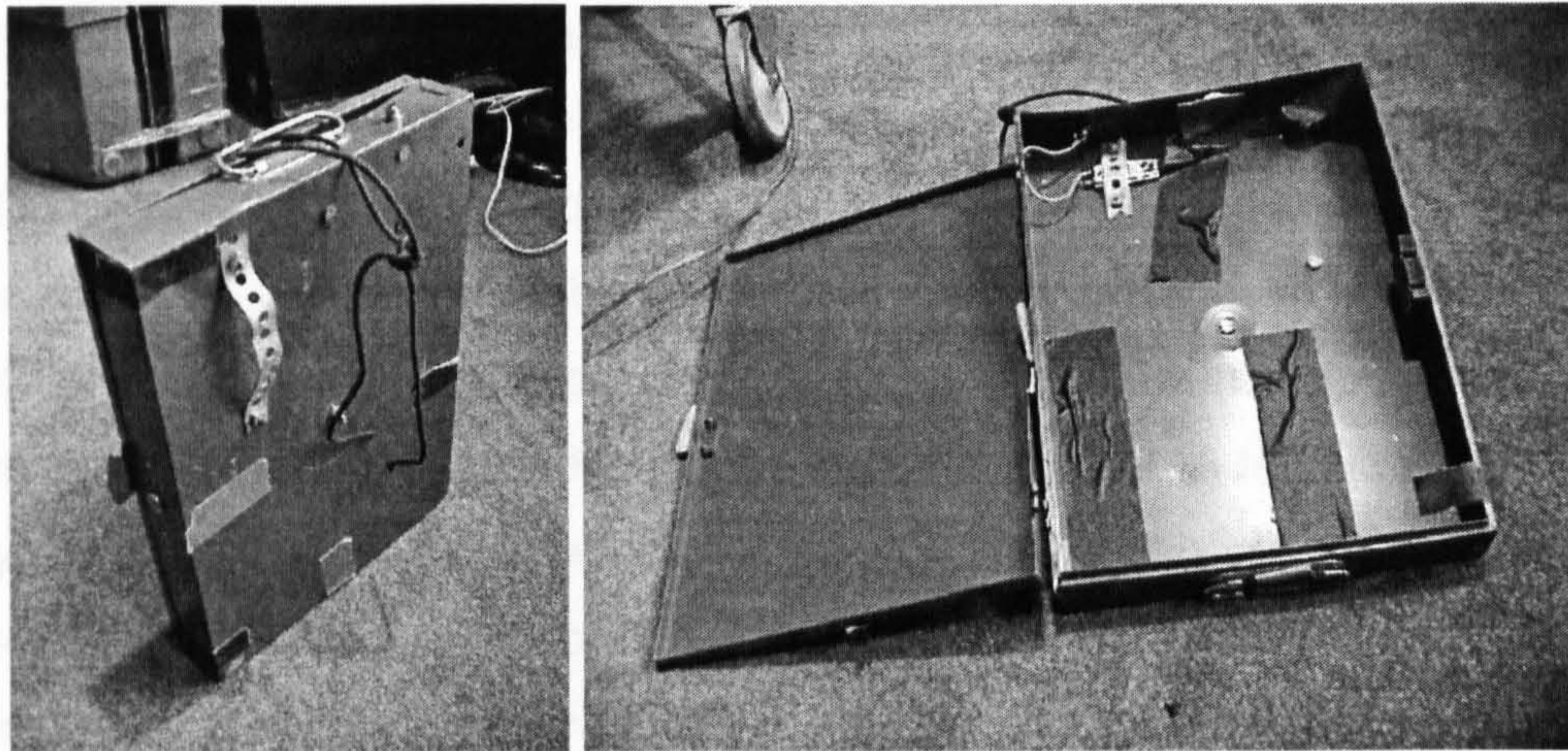

Figure 3-7. "Metal box" included on list taped inside eight-channel briefcase amplifier. Note contact microphone (phonograph cartridge) permanently mounted inside box, with an output jack for connecting to a sound system. Photographs by Matt Rogalsky, 2001.

cymbal. The boxes made of wood and metal are still extant: as shown in Figures 3-6 and 3-7, they currently reside along with the briefcase amplifier in the World Instrument Collection at Wesleyan University,

Examining the metal and wooden boxes, we can see that both are prosaic "found objects". The wooden box (Figure 3-6) is in fact a substantially unaltered, somewhat kitsch household countertop container of the type used to store sugar or flour. It is approximately 8" x 10" x 10", with a fitted lid which is completely removable, and is decorated with a colourful stencil of a rooster. The 1969 Cunningham Company equipment list describes it as "wood box with 2 Rolen-Star transducers, phono cartridge and accessories" (Cunningham Dance Foundation 1969b). Indeed, the box as seen today has hardware fittings for attachment of two transducers, and inside is an aluminum bracket which once held in place a phonograph cartridge to pick up the box's resonances; a female RCA-type jack for output from the cartridge is still in place, mounted on the exterior of the box for easy access, with a cable extending inside which was once soldered to the cartridge.

How the cartridge was mounted inside the box is made apparent by the example of the sister "metal box" (Figure 3-7), which is described in the 1969 list simply as "metal box with phono cartridge and accessories" (Cunningham Dance Foundation 1969b). As seen today, it is also a basically unaltered found object: a broad, shallow metal cash box made of thin steel, measuring approximately 12" x 10" x 2", with a hinged lid and a mounting point for a Rolen Star-type transducer. A female RCA-type jack is mounted on the exterior (as with the wood box), and in this case it is found still to be connected to a phonograph cartridge, which is firmly attached to the bottom of the box's interior via a strip of aluminum. In Figure 3-8, a detail of the cartridge is shown, clearly illustrating how it is situated as a pickup, and also reinforcing the connection of Tudor's *Rainforest* object concept with Cage's *Cartridge Music* objects: the same means of amplification are utilized in an identical manner.

In order for the cartridge to "hear" the vibrations of the metal box, a stiff wire connects the two, extending from a hole in the cartridge (intended to receive a stylus for playing phonograph records) to the body of the box. Vibrations of the box are conducted through the stiff wire to a pickup element inside the cartridge.

Two further metallic items, the "cymbal" and "sheet" from the briefcase list, are also found on the 1969 Cunningham list, and are visible set up for performance in the background of Gordon Mumma's second 1971 photograph (Figure 3-3). The "sheet" is a piece of sheet metal. The "cymbal" on Tudor's briefcase list is a 20" Zildjian brand cymbal which is now part of the Wesleyan Instrument Collection. Use of the cymbal—a musical instrument—as a *Rainforest* loudspeaker, is perhaps unique in the piece's entire history. Although not formally excluded from consideration at any point, objects which are already musical instruments seem to have been otherwise completely bypassed in favour of found

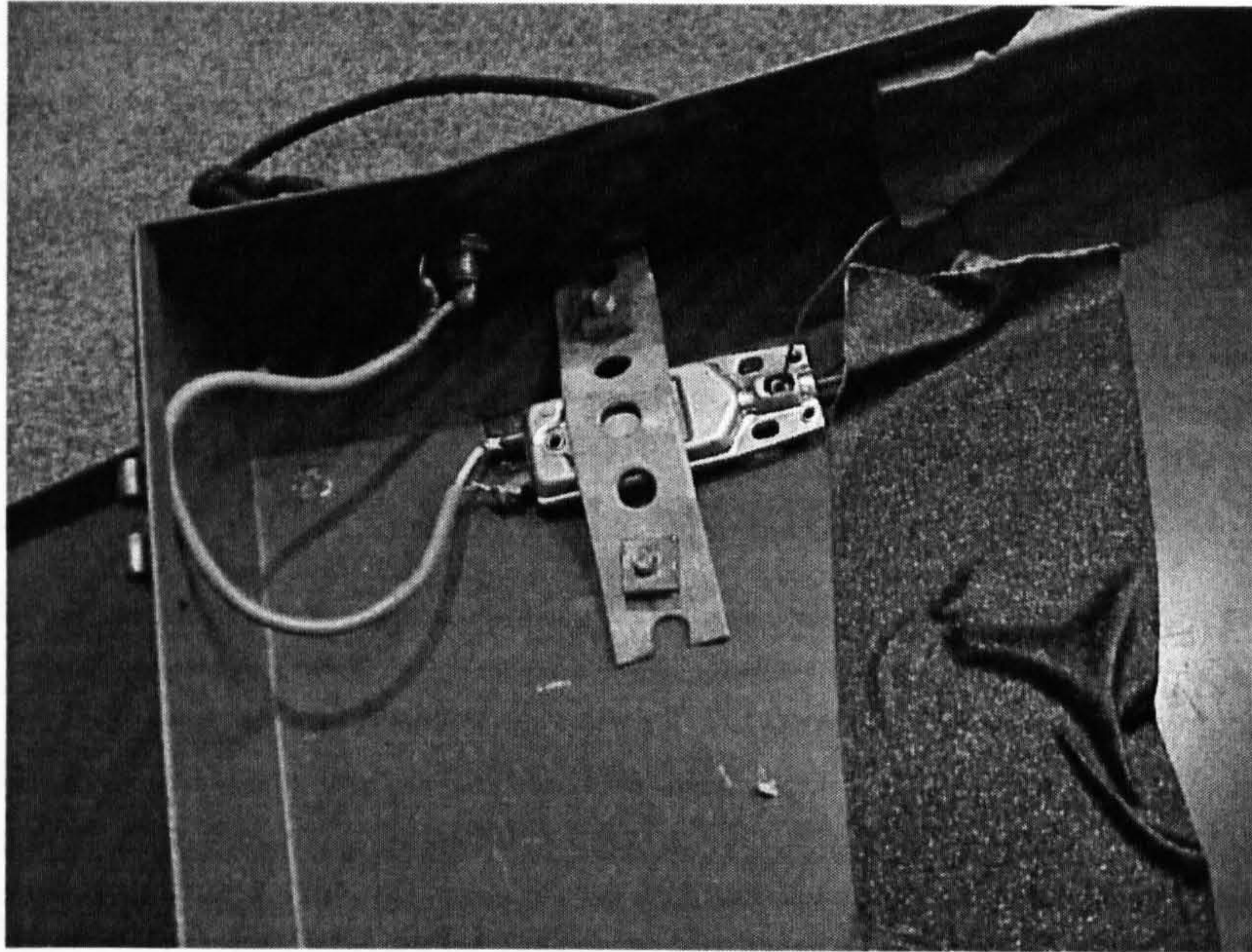

Figure 3-8. Detail of phonograph cartridge mounted in metal box, showing extension of stiff wire from stylus hole to body of the box itself, to conduct vibrations to the cartridge's pickup element. Photo Matt Rogalsky 2001.

objects of the wood and metal box type. This has been true through all versions of *Rainforest*; the later specific injunction in *Rainforest 4* against use of "composed musics" as source material seems to echo a general desire on Tudor's part to avoid "preinvented instruments". This is perhaps because conventional instruments have known acoustic properties (and therefore are perhaps less interesting than found objects, which have unknown resonances to be discovered) and possibly also because existing instruments would have been a link to Tudor's fading identity as a performer of acoustic music. Of Tudor's choice of a cymbal, it is interesting to recall that John Cage's *Cartridge Music* includes an option for realization as *Duet for Cymbal*: "[...] employ a contact microphone on the instrument [...] lower cymbal into water or onto piano strings or onto a mat or other material or make some such action that changes the sound radically" (Cage 1960).

Another unusual item found on the briefcase list is the object notated simply as "string". The elaborated description of this item on the 1969

Cunningham list is "metal pan with piano string and Telostar transducer": the transducer, attached to one end of a piano wire, resonates the metal pan attached to its other end, where the vibrations are picked up by a phonograph cartridge. This arrangement would be best referred to as a "compound object", the term later coined by John Driscoll to describe *Rainforest 4* loudspeakers made of two or more objects joined together. In such a case transducer and pickup are typically attached to different segments of the compound object, so that the resonances amplified by the cartridge pickup are being indirectly activated. In the case of the "string" construction, vibrations of the transducer would have been transmitted to the metal pan through longitudinal movement of the wire, causing the pan to resonate.

The "springs" object was also apparently a type of compound object, functioning in a manner similar to the "string" but employing Slinky-type metal coils. Precise construction details are unavailable (and, as Gordon Mumma (2005) reiterates, "by Tudor's constant rearranging, nothing was the same twice") but would have functioned similarly to the device in Figure 3-9, which John Driscoll recalls predated the development of *Rainforest 4* in 1973 and may have been used in *Rainforest 1* (Gordon Mumma (2005) suggests this device was not used on tour with the Cunningham Company, because it would have "required too much 'installation' work"). Constructed on an X-shaped frame made of half-inch metal pipe, it incorporates four Slinky-type springs stretched loosely, one on each arm of the "X"; each spring had a dedicated transducer on its outer end, and all springs met at the center where one or more pickups were located. John Driscoll remembers Tudor used this in performances of *Rainforest 4* in 1975 and 1976. After Tudor's death in 1996, Driscoll constructed a new one for a 1998 performance of *Rainforest 4* in New York City, since the old one found at Tudor's home in Stony Point was by then too rusted and corroded (Driscoll 2005a).



Figure 3-9. "Springs" object as installed as part of *Rainforest 4* at Fort Worth Art Museum, October 1975. Four Slinky-type springs each with its own transducer. Photo courtesy John Driscoll.

This type of compound object was a common feature of the much later *Rainforest 4* installation piece, but was generally employed by performers other than Tudor, who carried on primarily using single "found objects". The "string" and "springs" objects are therefore both relative rarities in the history of Tudor's *Rainforest* objects, although we can see antecedents in his loudspeaker constructions for *Bandoneon !* in 1966, which exhibited some "compound object" characteristics.

The two remaining items on the briefcase list which have not yet been addressed are also made of wood and metal, the "wood tray" being a simple serving tray (also included with the Wesleyan collection), and the "coil" likely to have been a heavy type of spring as found in a screen door, with a unique ringing resonance of a type heard intermittently in recordings of *Rainforest 1*. Gordon Mumma (2005) suggests this type of spring was used. John D.S. Adams (2005) suggests an even heavier type

of spring might have been employed, such as that found in an automobile suspension.

To summarize, the sonic qualities of the entire collection of objects can be described as divided between "wooden" and "metallic", weighted heavily toward the latter: six out of eight of the objects on Tudor's briefcase list. Metallic objects are tempting to use because they typically respond well to a variety of input signals; the collection Tudor assembled represents a great diversity of sonic possibilities, despite the fact that they are all materially related. They are of such varied construction that none would duplicate the resonances of another. The risk in such a situation would be to have an overabundance of similarly metallic timbres, but this is not the case as is clear from auditioning the set of *Rainforest 1* recordings. This illustrates an important unwritten *Rainforest* "rule" which should in fact be self-apparent: objects should be selected for diversity of sonic possibilities.

Of course there is no certainty that the list of objects mounted inside the briefcase amplifier represents a fixed set of items used continuously over several years of touring *Rainforest 1*; Gordon Mumma has said on several occasions that the only thing constant in Tudor's practice was change. But the fact that the handwritten list exists—affixed to the briefcase as a memory aid for setup and performance of the piece—and that six of the eight items on that list are also listed on the 1969 Cunningham Company equipment list is persuasive evidence that it well represents Tudor's range of *Rainforest 1* loudspeakers.

Rediscovering the technology behind *Rainforest 1*

The focus of *Rainforest* is the acoustic transformation of electronic sounds, and Tudor's descriptions of the piece tend to focus on that end rather than the means of production of the electronic sounds. In my own creation of new performances of "*Rainforest 1*" (set in quotation marks

since I wish not to infer that I am recreating a historically "authentic" version), I have taken the approach that my electronic sound production need not attempt to replicate Tudor's methodology; nor could it since I am not creating a performance with his "original instruments". But an understanding of the type and range of devices which were used in his performances helps to give a fuller picture of the piece, and suggests directions in which to develop new performances of what could still be said to be "*Rainforest 1*", despite the fact that its soundmaking means may be substantially different.

The characteristic sounds of Tudor's *Rainforest 1* have already been described as falling into four categories, to reiterate in brief:

- steady-state sounds
- "knocking" and "tapping"
- "whoops", "chirps" and "chatters" ("animal/bird" sounds)
- "machine-like" sounds crossing over into the previous category

Using the 1971 photographs by Gordon Mumma as a guide, and aided by the 1969 Cunningham Company equipment list, the devices which Tudor used to create sounds in each category can, in some cases, be concretely identified from among those in his collection at Wesleyan University. Some are pieces of commercial equipment and, as such, are easily understood and of lesser interest than the "hand-built" equipment. This latter category includes some devices which were actually constructed "from scratch" by Tudor, but more often than not these devices, which are packaged in idiosyncratic plastic or metal boxes, are based on then-commercially available circuit boards. Tudor's usage of these boards as a platform for "hardware hacking" is open to examination; almost certainly some of these circuits were being used in ways which their designers had not envisioned, but whether Tudor's exact usage of most of the devices can be confirmed is unlikely.

Having identified the devices, one would hope they could be coaxed to "speak" again, but this has sadly not been the case with most of them; their circuits are, in some cases, covered in mold and mildew, after years of disuse and poor storage conditions at Tudor's home in Stony Point, New York. There exists the possibility of recreating the circuits with new components, but then there is also the question of how these devices were connected, and interconnected: for the most part, none are labeled as to their usage. We will see, however, that at least one clear-cut case exists of a soundmaking device which Tudor did build from the component level, and which is still in excellent condition, thus making it possible to audition. It is one of the most readily identifiable types of sounds on the various recordings of *Rainforest 1*, so there is some satisfaction in being able to hear it and experiment with it.

Presented in Figure 3-10 is a numbered version of Gordon Mumma's 1971 equipment photograph as already seen in Figure 3-3, with annotations for the nineteen items set up on the table. The majority are part of the Wesleyan collection; one of Mumma's boxes was identified from notes in Tudor's archive at the Getty Research Institute. Some devices of the "hand-built" variety have not been found; they may have been disassembled or discarded.

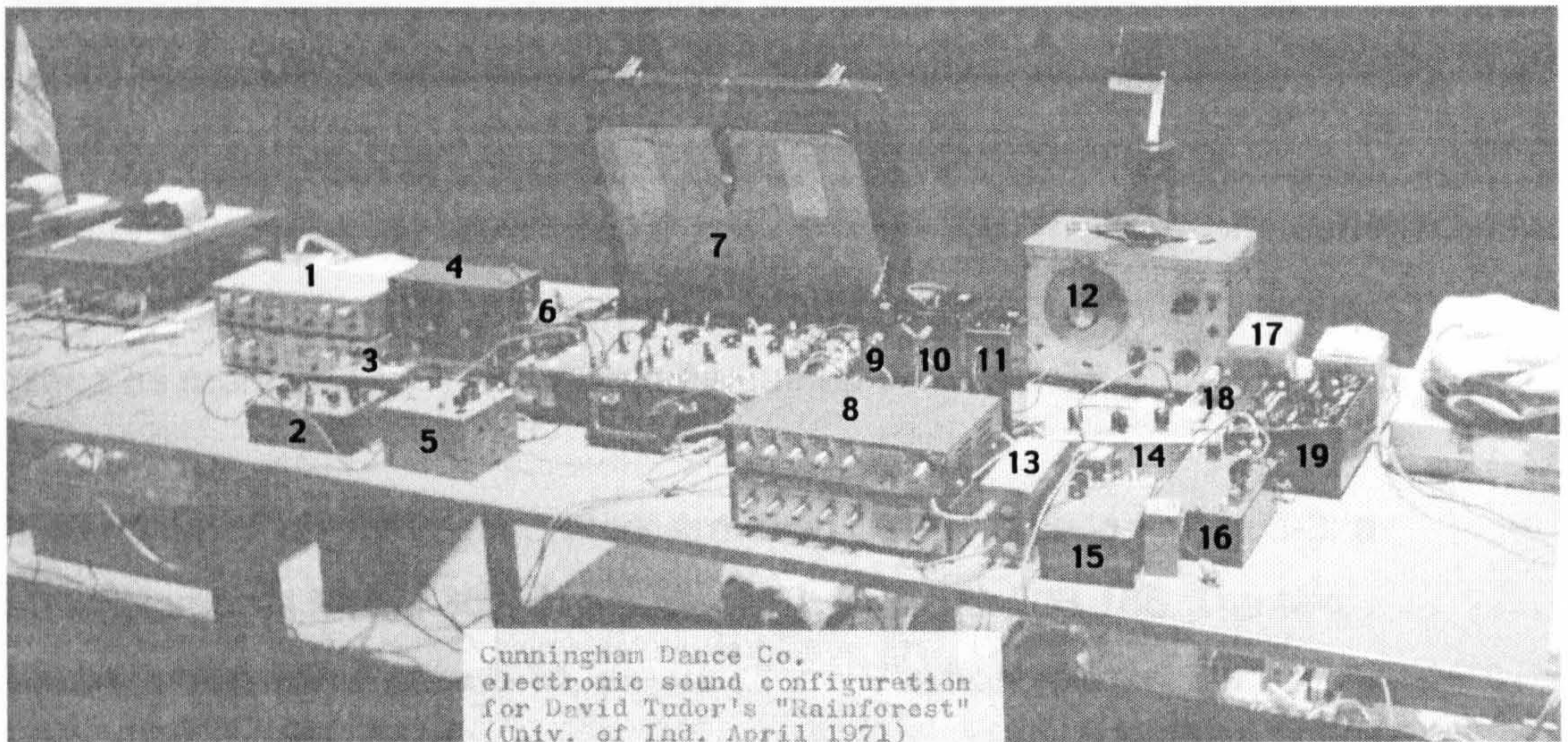

1. Two four-channel "tone-control preamps" (for pickup signals returning from two loudspeaker-objects). Items identified as "Stereo Mike Mixer MM-3", manufacturer unknown **#0236 / #0273**.
2. Unidentified (not found in Tudor instrument collection).
3. Unidentified (not found in Tudor instrument collection).
4. Nombrex Ltd. audio generator, model 30 (sine/square wave oscillator) **#0369**.
5. "Miniature oscillator for *Rainforest*" constructed by Gordon Mumma.
6. Unidentified (obscured by 7.).
7. Eight-channel amplifier built into briefcase **#0123**.
8. Two four-channel "tone-control preamps" (for pickup signals returning from two loudspeaker-objects). Olson RA-637 four-channel transistor preamplifier mixer, **#0237 / #0238**.
9. Feedback oscillator (presumed) **#0463**.
10. Feedback oscillator (presumed) **#0465**.
11. Feedback oscillator (presumed) **#0466**.
12. Midland audio generator, model 23-165 (sine/square wave oscillator) **#0419**.
13. Dual preamplifier **#0176**.
14. Pulse generator **#0474**.
15. Preamplifier (possibly used as feedback oscillator) **#0230**.
16. Unidentified.
17. Unidentified.
18. Unidentified.
19. Olson TE219 capacitor/resistor substitution box **#0249**.

Figure 3-10. Setup for performance of *Rainforest 1*, 1971. List of items includes numbers in bold assigned for cataloguing as part of Wesleyan University's World Instrument Collection. Photograph by Gordon Mumma (see also Figure 3-3).

Simple oscillators: steady-state sounds

The simplest category of soundmaking equipment to address is that which involves primarily commercially-produced devices: test-tone oscillators. As has been described, the premiere performance of *Rainforest 1* seems to have been made primarily with this type of steady-state sound source, and these sounds remained a strong feature of the piece as more active, "chirpy" sounds gained prominence.

Two commercial audio generators are seen on the table in Figure 3-3: a small Nombrex Model 30 and a larger Midland Model 23-165. The two, shown in detail in Figure 3-11, are functionally almost identical, a common type of test equipment capable of producing sine or square waves at frequencies ranging from 1Hz to 110kHz. At the extreme low end (below 20Hz), a square wave would become heard as a pulse, useful for ringing an object's resonances; these pulses define the next category of sounds, produced not only by these commercial oscillators but, more interestingly, by purpose-built pulse generators.

Identification of the Nombrex Model 30 is based on a visual inspection of the Mumma photograph, which appears to show the exact device which is part of the Wesleyan instrument collection. There is no Nombrex device included on the Cunningham Company 1969 list; however, a Nombrex Model 30 audio generator is entered on a much later Cunningham equipment list (Tudor 1982).

Sine and square wave drones play an important role in all recordings of *Rainforest 1* considered here. Other steady-state sounds heard include broad-band noise sources, which may include some of the unidentified devices shown in Mumma's photographs; there are two "custom-built white noise generators" documented on the 1969 Cunningham list but these have not been identified. A white noise source is clearly heard, however, in at least two of the undated recordings.



Figure 3-11. Nombrex Audio Generator 30 and Midland Model 23-165 Audio Generator, as seen in *Rainforest 1* setup in Figure 3-3. Photographs by Matt Rogalsky 2004.

Broad-band pulses: rhythms and drones

The commercial test-tone generators cross over into the territory of rhythm, since their frequency range extends into the subsonic region. Likewise, the two handbuilt oscillators considered in this section do

double duty, reaching from the subsonic region of individually perceived pulses into the area of pitched sounds above 20Hz.

The first of these is a device constructed by Gordon Mumma and seen as item 5 on the 1971 *Rainforest 1* table in Figure 3-10. This is the same item described as "miniature oscillator for *Rainforest*" in a memo to "John [Cage] and David [Tudor]" (Mumma 1970)—written as a brief guide to sound equipment for *RainForest* and other Cunningham dances, apparently during Mumma's absence. Mumma's memo includes a drawing of the device, reproduced below in Figure 3-12.

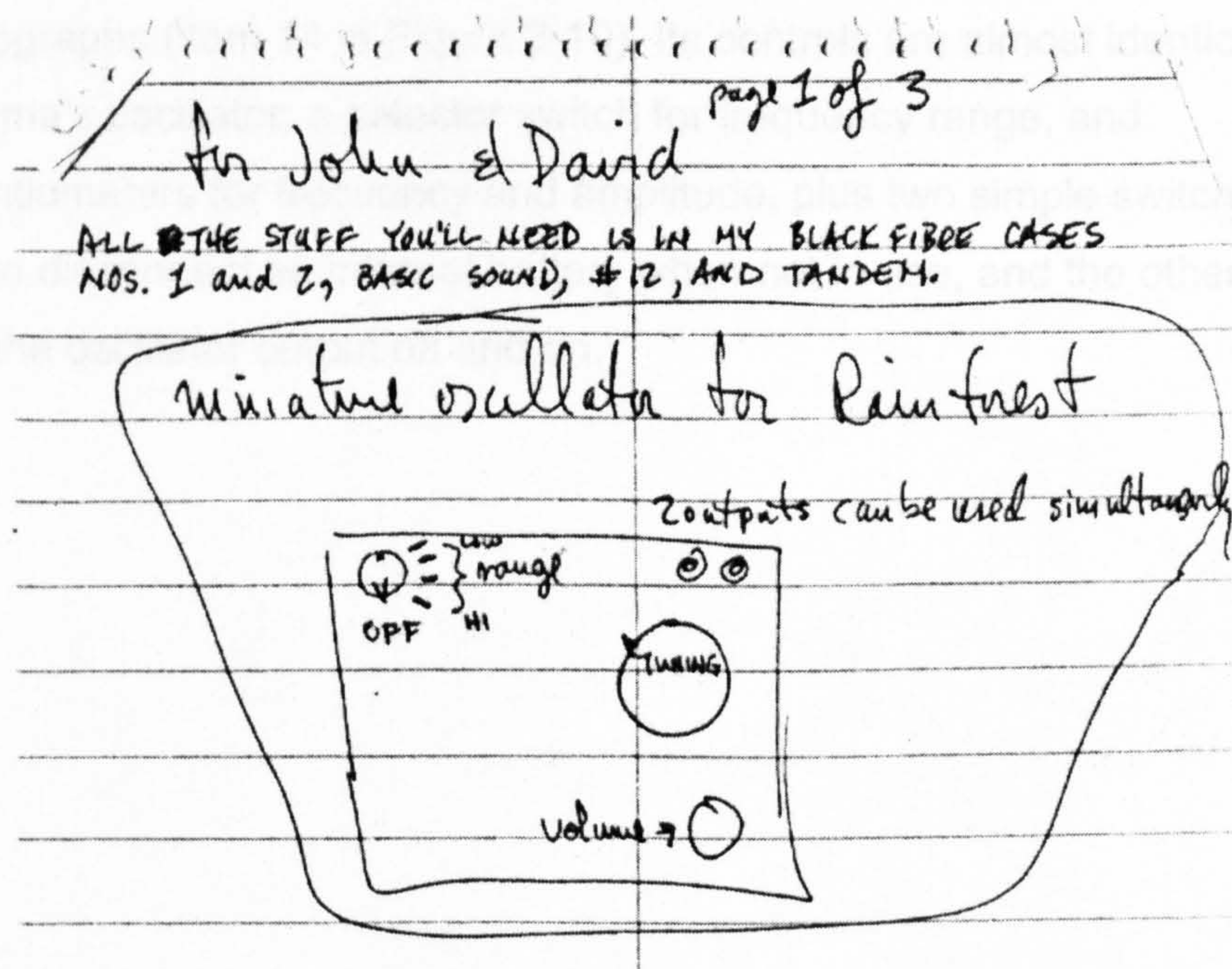

Figure 3-12. Portion of first page of memo from Gordon Mumma to John Cage and David Tudor, regarding sound setup for the Cunningham Company (Mumma 1970).

The oscillator's function is easy to understand, and in fact is basically identical to the commercial units: a switch selecting one of several frequency ranges, and two potentiometers, one for tuning (frequency) and one for amplitude. Mumma (2005) says of this oscillator that it was

[...] a device I made to simplify the logistics of MDCDC Rainforest performances done by Tudor and Cage (when I had engagements

elsewhere). One of the original sine-wave (with sweep function) oscillators was vacuum tube, and large. The one I designed and made was all transistors, and ran on self-contained batteries, to minimize power-cable clutter. Remember that Cage, though of brilliant mind, didn't attend to much of equipment setups with the MCDC -- that's what I did, and Tudor did for most of his Rainforest stuff. I gave Cage a "private lesson" so he could plug in my mini-oscillator by himself. Then made that page of instructions to free his (and their) memories of logistical trivia.

David Tudor includes two "custom-built pulse generators" on the 1969 Cunningham list; one of them may be the item seen in Figure 3-13, which definitely does appear on the *Rainforest 1* table in Mumma's 1971 photographs (item 14 in Figure 3-10). Its controls are almost identical to Mumma's oscillator: a selector switch for frequency range, and potentiometers for frequency and amplitude, plus two simple switches, one to disconnect an internal battery when not in use, and the other to turn the oscillator output off and on.

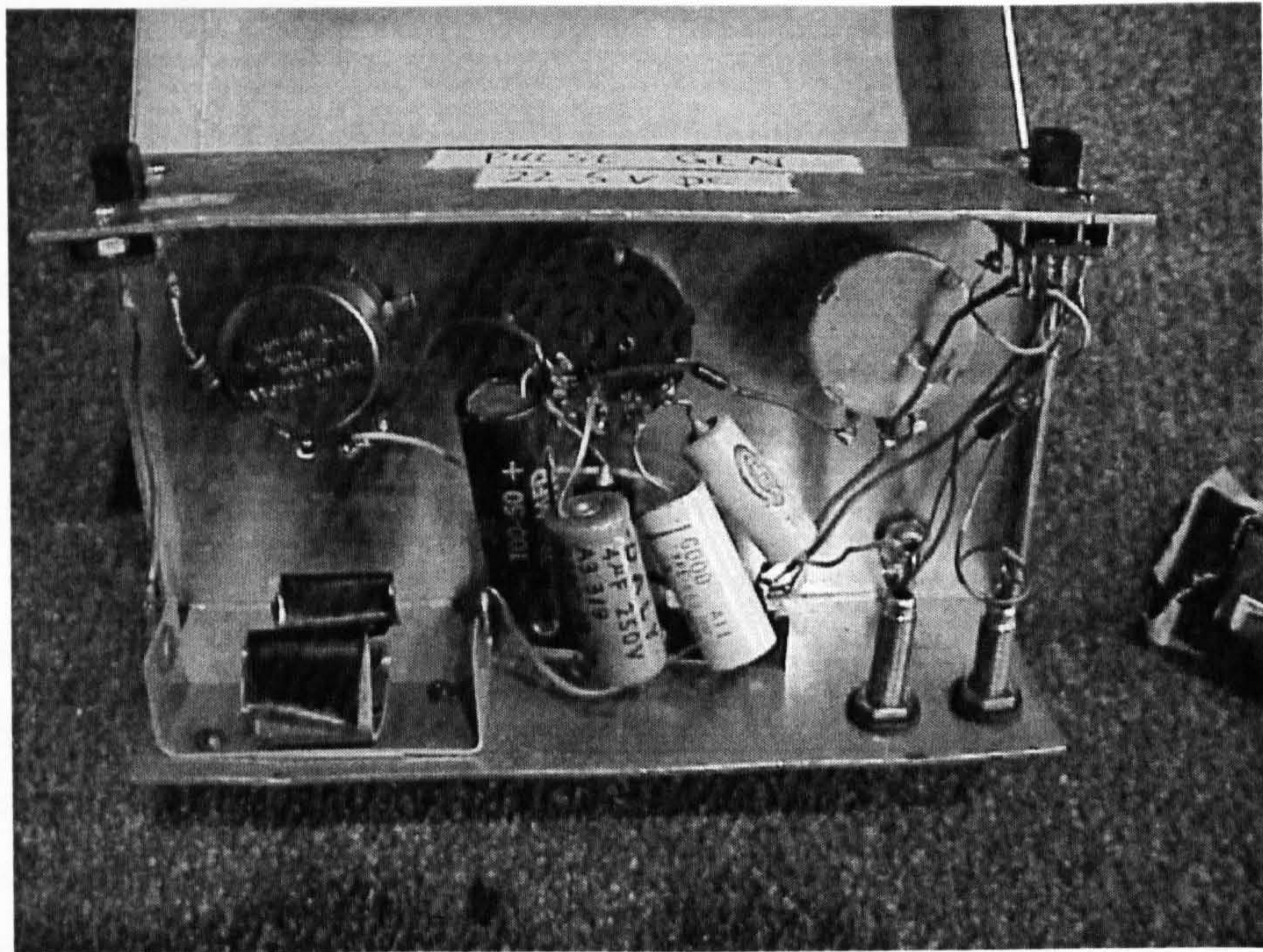
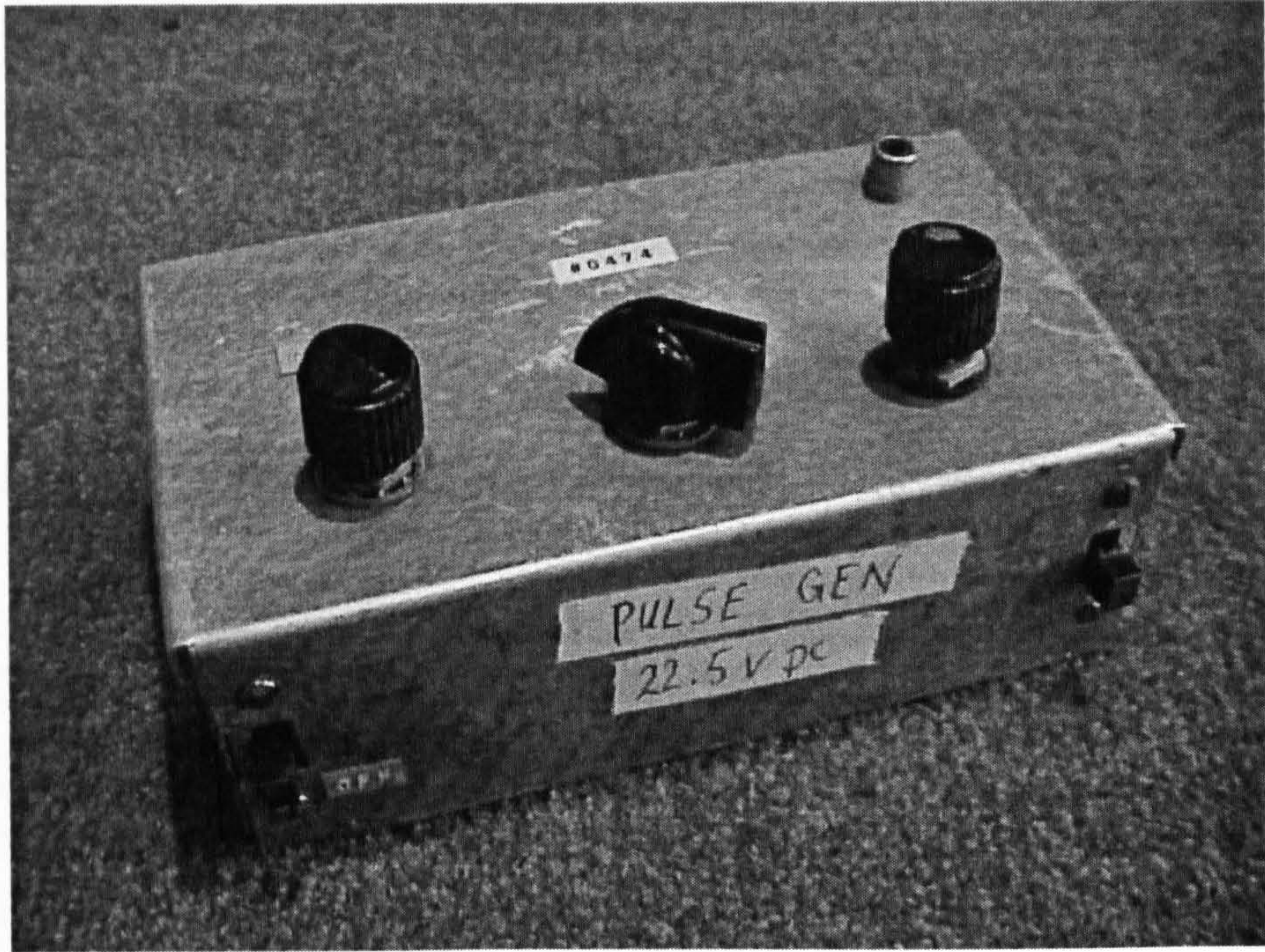

Figure 3-13. External and internal views of pulse generator constructed by David Tudor and used in performances of *Rainforest 1*. Photographs by Matt Rogalsky, 2001.

The frequency range of Tudor's pulse generator is quite wide, extending from audio rates down to sub-audio ranges, with the lowest setting producing only one pulse about every ten seconds. This extremely slow rate is used to great effect in the recordings of *Rainforest 1* which are considered in this chapter: a very slow pulse, producing a wooden knocking or tapping (presumably via the transduced "wood box" or "wood tray"), is used early on in two of the performances as a ground over which to perform more quickly-changing sounds. In one case (Brooklyn Academy of Music 1972), such a pulse is introduced about a minute and a half into the performance and remains quietly in the background for about seven minutes, quietly but clearly heard among the other sounds. Later the slow pulse returns for another several minutes. In most of the recordings, slow pulses make significant appearances, and their effect is something like a dripping tap; the next pulse seems inevitable, but is always unexpected.

Pulses approaching audio rate, but still identifiable as individual pulses, also play a significant role in the soundworld of *Rainforest 1*. In the 1970 concert performance recording of Tudor and Mumma, multiple pulse generators are employed throughout, at varying speeds which cross the boundary between audio and sub-audio rate, and the performance ends with fast and slow pulses in combination.

Tudor's pulse generator in Figure 3-13 is one of the few entirely "hand-built" devices in his collection which is still in good condition for testing, has an unquestionable purpose, and is also relatively easy to understand on a technical level. When its case is opened we see a cluster of capacitors, and very few other components. Viewing a schematic diagram for the circuit (Figure 3-14), it is shown to be a simple RC (resistance-capacitance) network, where the resistor and capacitor values are variable. The variable resistance and capacitance are combined with an antiquated 'Shockley' diode, to form a relaxation oscillator.

One of the capacitors at a time may be switched into the circuit, providing a frequency-range setting (upper and lower frequency bounds). The 'pulse-rate' potentiometer then varies the frequency of pulses within the selected range. A second potentiometer controls how much of the signal appears at the output.

The circuit functions by drawing on a 22.5 volt battery, to charge the selected capacitor through a fixed resistor and a variable resistor in series. The capacitors range in value from 0.05 to 100 microFarads and the resistance is continuously variable from 47k to 547k (kilo Ohms). The larger the resistance and capacitance values, the longer it will take for the capacitor to charge, following an exponential curve. When fully charged, the capacitor would remain at that level if not for the presence of the diode in the circuit, of an obsolete "Shockley" type. Conventional diodes pass voltage in one direction and block it from passing in the other direction; the Shockley diode has the property of preventing voltage from passing until a breakdown threshold is reached, at which point it suddenly releases the charge stored in the capacitor. This is heard at the signal output as a pulse. When the voltage level falls, the diode ceases to conduct, and the process begins again, with the capacitor once again being charged through the resistors. As already stated, the combinations of resistance and capacitance values in Tudor's circuit offer audio rate pulses (greater than about 20 per second) as well as extremely slow sub-audio rates (as slow as one pulse about every ten seconds). No variation is possible without manually changing the device's settings, which judging from the behaviour of the pulse generators heard in the *Rainforest 1* recordings, seems to have been a typical part of performance practice. Tudor's pulse generator has an additional performance control (not included in the schematic in Figure 3-14): a simple on/off switch for its audio output. There is also a second switch to disconnect the battery when not in use.

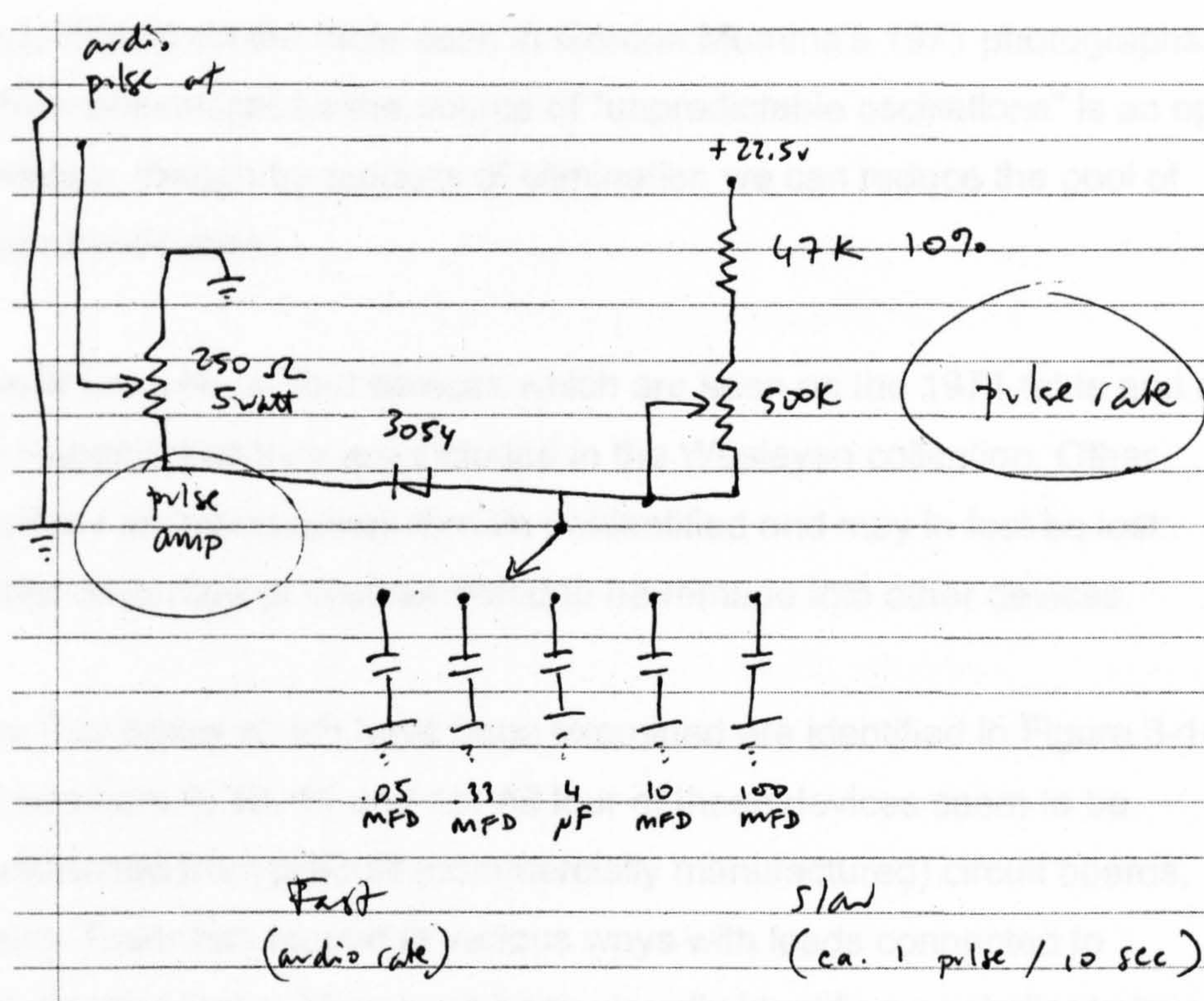

Figure 3-14. Circuit diagram for David Tudor pulse generator device as shown in Figure 3-13. Rotary switch selects one of five capacitors, defining frequency range, and 500k rotary potentiometer in series with 47k resistor defines the output frequency within the selected range. The diode numbered 3054 is an obsolete 'Shockley' type which serves the function of creating each 'pulse' by suddenly releasing the stored charge of the capacitor when it reaches the diode's breakdown level. Original schematic by Matt Rogalsky, 2001.

Whoops, chirps, chatters and "machine noises"

[in] the first [*Rainforest*] I had used oscillators that made animal like and bird like sounds (Tudor 1984).

The source sounds used are performed live, with sound generators specially made to produce unpredictable oscillations [alt. "give unpredictable waveforms"] (Tudor 1988a)

I experimented with feedback amplifiers that were capable of unpredictable oscillations (1988a).

Of the many items on the 1969 Cunningham inventory, 24 are identified as "custom-built" and belonging to David Tudor. Some of these are

undoubtedly on the table seen in Gordon Mumma's 1971 photographs. Which ones might be the source of "unpredictable oscillations" is an open question, though by process of elimination we can reduce the pool of probable devices.

I have focused on four devices which are seen on the 1971 table and can be inspected as they are included in the Wesleyan collection. Other similarly intriguing boxes remain unidentified and may in fact be lost: either discarded or disassembled to be remade into other devices.

The four boxes which have been examined are identified in Figure 3-10 by numbers 9, 10, 11 and 15. All four of these devices seem to be constructed from prebuilt (commercially manufactured) circuit boards, which Tudor has tapped in various ways with leads connected to input/output jacks. They have been visually identified as similar to low-power transistor amplifier modules produced by Lafayette Electronics and other electronics hobbyist supply shops of the 1960s (McGarrah 2005).

One of the four devices (No. 15) is in good enough condition to permit it to be tested with a power source and an audio signal input: the box has two female RCA jacks which are labeled "In" and "Out" (in contrast to the other three devices which are entirely unlabeled). When tested, this box seemed to function as an unremarkable preamplifier circuit, with a highpass filter effect that could be switched in and out. The fact that this device did not immediately begin producing "bird-like" sounds or something similar when tested, is not unexpected; if it was ever involved in production of such sounds, it might have been used in a feedback loop on its own or in combination with other devices. As seen on the 1971 *Rainforest 1* table, it seems to have only its output jack connected (to what, is not visible), but the photograph may not represent the "finished" setup of devices, and in any case Tudor was well-known for non-intuitive connections between devices: John Driscoll (1997) stated that "David Tudor would often use inputs as an output. Outputs would also be used

as inputs. It rarely mattered to David what the original intention of the circuit was as long as it produced a range of unpredictable sounds".

The other three devices, each packaged in a black plastic case, as seen in Figure 3-15, are also built around what appear to be transistor amplifier circuit boards. The circuits themselves seem to be unmodified, but each has a number of "extensions" from various points in the circuit, leading to banana plug-type jacks mounted on the case (see lower photograph in Figure 3-15). Some of these are for power connections: despite the fact there is a battery connector inside the box, Tudor often made it possible alternatively to connect one external power supply to multiple devices. Apart from the power connectors, the remainder of the banana plug-type jacks are access points into the circuits, where the boxes can be connected together (or back into themselves), to create the type of feedback circuit that might produce the types of "naturalistic" whoops, chirps and chatters which are so much a part of the *Rainforest 1* soundworld. Unfortunately these three boxes were discovered in poor condition, the circuit boards covered in mold and mildew, and no attempt has been made to power them.

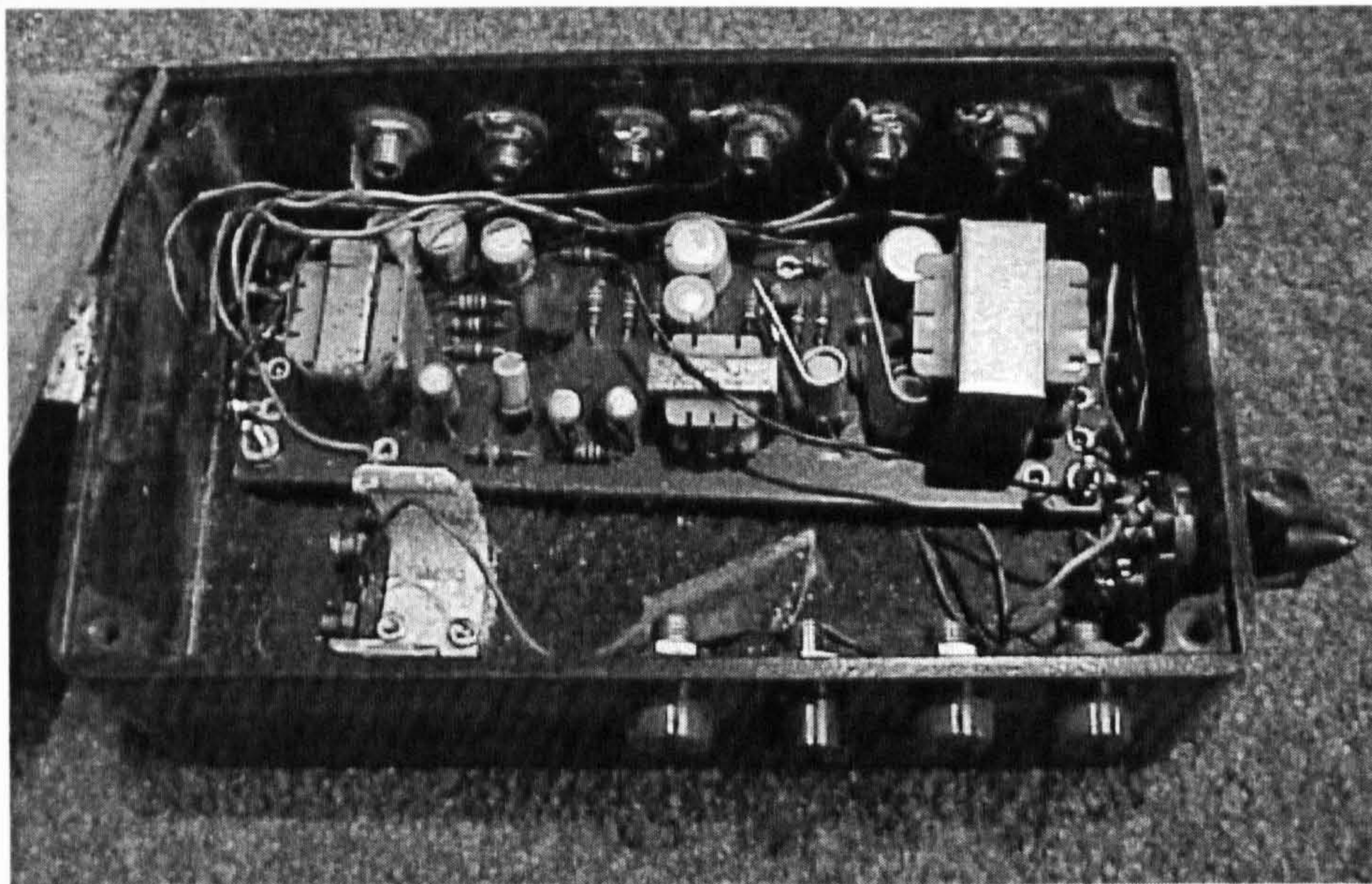

Figure 3-15. Top: three devices constructed by David Tudor based on commercially available amplifier circuit boards. Their catalogue numbers in the Wesleyan Instrument Collection are, left to right: 0465, 0463 and 0466. Bottom: interior view of 0465, showing prefabricated circuit board and numerous banana plug "points of access" into it, presumably for use as a feedback oscillator. Photographs by Matt Rogalsky, 2005.

More study needs to be made of the prefabricated circuit boards, to ascertain the manufacturer and model number of the circuits, if possible; schematics may be obtained and the principles of possible interconnections studied. Two of the devices in Figure 3-15 each have six banana-type jacks, and the third has four; the many points at which the circuits have been "hacked" suggest rich possibilities, but as they are all unlabeled we must rely on informed experimentation to reveal their use. The use of such simple amplifier circuits to produce sound via electronic feedback is found again and again in Tudor's practice following *Rainforest 1*; the principle was developed into a significant body of work of which the acknowledged virtuosic pinnacle was 1972's *Untitled*, a piece created entirely from feedback internal to a complex chain of dozens of devices. *Rainforest 1* can be imagined as a site of initial exploration for techniques which formed the kernel of *Untitled* and other later important works.

The arrangement of simple gain stages into chains which operate as complicated oscillators was a talent of Tudor's, which seems to have come about without overt intention, as he describes in a 1984 interview:

My view is more or less what Billy Klüver said, when he asked me what I was using and I ran down the list of things that were available to me and he said to me: "Oh, you only have amplifiers" and you know, that like a light going on in my head, and I said "yes, that's exactly what it is. It's all gain stages of one kind or another". And that all came about in the first place because of my having a lot of equipment that I built myself where there was no question of a power supply common, so the voltages present were constantly unpredictable (Tudor 1984).

A similar story, from another occasion, is told by Nicolas Collins (1996, 95):

One day in 1982 I was sitting with David Tudor in the breakfast room of a small Dutch hotel, trying to help him repair one of his circuits. [...] the phrase "your music's all about gain, isn't it?" popped out of my mouth [...] David looked up, slightly startled, and said, "you're right, and you're the first person to have said that. [...] Most of David's individual modules were rather simple [...] but the

undulating signal level as it passed through the network defied analysis [...] Whereas much attention has been focused on David's obsession with the loudspeaker as an active musical instrument (rather than a mere passive conduit for sound), the ups and downs of the amplification process that precede it bear scrutiny as well.

The "unpredictabilities" of *Rainforest 1* oscillations produced in this manner are part of the naturalistic effects achieved in its performance; amplifiers in feedback tend to produce semi-rhythmic chains of pulses, and a range of sounds which may be animal-, bird- or machine-like, repeating inexactly, with built-in irregularities. Tudor's use of feedback in fact extends back to *Bandoneon !* in 1966: Billy Klüver (2002) stated that in that piece, Tudor was "basically working with the original sound and then amplifying it, narrowbanding it, introducing feedback, those are basically the three elements". The basic elements of amplification, equalization and feedback are also essential parts of *Rainforest 1*'s sound production, resulting in effects which have frequently been described as "chaotic."

Bill Viola (2004, 54), for instance, quotes Gordon Mumma as saying that "the two key elements to Tudor's work were resonance and chaos". David Behrman (1997, 73) comments that Tudor's use of feedback for sound production has "practically nothing to do with any part of music history [but] could be related rather to chaos theory, which was being simultaneously developed by Mandelbrot and Feigenbaum during the years when Tudor was wiring feedback circuits into little plastic soap-boxes in his house in Stony Point". Grant Chu Covell (2003), describes Tudor's performances as "finding the right balance between order and chaos". In my own writings about Tudor I have also described his use of "unpredictable" electronic sounds as a harnessing of "chaotic" energy (Rogalsky 2002, 8).

Billy Klüver (2002), however, disputed laypersons' references to chaos as they perceived it at work in Tudor's musical practice:

Well, it's a matter of your own personal definition, what you want. I wouldn't use the word chaotic, because chaos is such a loaded word. And it's, are you talking about your point of view, or the mathematical definition of chaos, or the *Scientific American* definition, or the radio commentator's definition? It's a word that doesn't mean anything. In terms of, say David's—all his circuits on his table, or whatever—it could never be chaotic. He is one human being sitting and using these four or five boxes and their connections, and have a time limit, a time element that's limited, say twenty-five minutes, or ten minutes, or five seconds. He is limited how fast he can move. It all boils down to a very pre-planned situation. That's what I learned. Everything was planned. Nothing was random.

[...]

I would say it's just like a human being, who can move this way, or... we can't fly, or, we don't slide on the ground, or something... those are modes he was trying to find. Modes of operation, so it gave a sound. Any circuit would just have a limited number of modes of operation, which depends on the feedback, and the capacitors and the resistors, and whatever in there.

Klüver agreed, however, that Tudor took delight in finding those situations where the circuit seemed to take on a life of its own.

Rainforest 1: conclusions

If the original devices built by Tudor for *Rainforest 1* are never again heard, if the devices are so corroded and mildewed that they cannot be used, even if just for testing, is that a problem for understanding, or continued performances, of the piece? David Behrman (1997, 74) has written, of Tudor's works of the early 1970s, that, "Perhaps not even Tudor could guess at the time of their creation that thirty years later these wonderful pieces would be almost impossible to resurrect. [...] The materials out of which his live electronic art was made turned out to be evanescent in a way that written language, music notations and even audio recordings were not". These are problems which afflict media arts practitioners in general, and have a bearing on continuation of Tudor's

musical practice, beyond the problem of how to parse out the workings of Tudor's devices in the first place.

On these topics, Behrman (1997, 74) continues,

When I began helping him [Tudor] in the Sixties I quickly learned not to ask too many detailed questions about his electronic music circuitry. It's not that he was secretive, exactly, but the inner workings of his artwork were private. [...] Fortunately for those of us who survive him, in the beautiful work called *Rainforest* David Tudor surmounted the problems of privacy and vanishing technology. [...] *Rainforest* is based on a generalized principle rather than on specific circuit design [...]

The "generalized principle" underlying *Rainforest 1* is, at its most basic, contained in the diagram shown in Figure 3-1, combined with the restrictions on sound sources to "only signal generators, any kind, as inputs. [...] (Note that simpler waveforms generally produce more complex results)". Whether or not we go beyond this to study Tudor's original devices, his recordings, his cryptic notes, an invitation to create *Rainforest 1* anew seems to be clearly extended. A relationship with the historical *Rainforest 1*, however, enriches the experience immeasurably.

Rainforest 2: recovering the unrecoverable

[*Rainforest 1*] was composed as a score for Merce Cunningham. I made eight small objects—they were small sculptures—and I programmed the objects with sound generators. For the second version, it was the same eight objects, but the sound material was John Cage speaking. (Tudor 1993)

This section dealing with the stage of *Rainforest* which David Tudor retroactively identified as *Rainforest 2*, might well be considered simply a postscript to the bulk of this chapter which explores *Rainforest 1*. Very little can be learned about the specifics of *Rainforest 2*, beyond the few

comments from Tudor which clearly identify what sets it apart from the other versions of *Rainforest*. Much detail seems destined to remain in the realm of speculation.

One concrete piece of information is the above quotation, found in a 1993 interview with Tudor: the most unambiguous description I have yet found regarding *Rainforest 2*'s performance. In these few words, Tudor conveys the sense that the second version of *Rainforest*, performed with John Cage's voice replacing the array of electronic drones, whoops and chatters, was not conceived as a major "next step", and not thought of, even in retrospect, as a radical departure from *Rainforest 1*.

Where and in what situations was *Rainforest 2* performed? A piece of information which helps to pinpoint the time period is found in the liner notes to the original LP recording of *Rainforest 4*:

Rainforest II, 1969-70, used only vocal inputs to the instruments, exploiting their characteristics as natural resonant filters, feedback being involved in the programming process (Tudor 1980).

This does not reveal specifically when the piece might have been performed, however.

Looking at the *Rainforest* options list in Figure 3-2, it would seem that options two and three together must define *Rainforest 2*, since they are the two which refer to the use of vocal sources. Option two ("One (speaking) voice only as input; the instruments acting as filters"(Tudor 1968)) echoes Tudor's much earlier idea for a permanent outdoor installation of resonating objects, as discussed in Chapter Two:

I thought that what I would like to do would be to make an orchestra of loudspeakers all having different 'voices' which would all receive a common input (Tudor 1984).

Option three ("As (2.) but with up to eight voices, singing or speaking") expands possibilities somewhat, presumably through use of prerecorded

tapes, although a version with eight different vocalists might equally be imagined, based on this brief description. I have presumed the latter possibility is unlikely, considering the few musicians touring with the Cunningham Company.

If John Cage was the source of the vocalizations, what was he speaking and/or singing? Tudor is quite specific about the era to which *Rainforest 2* belongs, and this is the period during which Cage was beginning intensively to focus on production of poetic text works: in an interview with Daniel Charles (1981, 113-114) in 1970, Cage says he was then working on

[...] a text [...] which deals directly with letters, syllables, etc., mixing them in such a way that you could call it a *Thoreau Mix*. It is my most recent work. [...] One day, I gave *Thoreau Mix* in the form of a lecture. It lasted forty minutes. Well, the result has no meaning, or only a very little. But while I was practicing for that lecture, I discovered that I could improvise, but only along the same lines! [...] I found this experience thrilling.

The "Thoreau Mix" Cage refers to, a text made up of references to music and sound in the journals of Henry David Thoreau, was afterward formed into "Music of Thoreau" or *Mureau* (also sometimes seen referred to by Cage as "*Mueau*"), which Cage performed solo on a number of occasions in 1971 and in simultaneous performance with David Tudor's *Rainforest 3* on tour in Europe in 1972. *Mureau* followed on Cage's *Song Books*, a sprawling work completed in 1970 which incorporated numerous styles of composition, text manipulation, and score materials. *Mureau* was sometimes performed by Cage solo, along with multiple prerecorded tracks of his own readings; the practice of using these prerecorded tapes hints at Tudor's *Rainforest* option 3, which calls for "up to" eight voices. Prerecorded tracks are clearly heard in the background of a performance recording of *Mureau* by Cage at New York University in 1971; Cage also used prerecorded tapes in his 1972 performances of the piece alongside Tudor.

Cage was likely already at work on his Thoreau text in early 1970, if not before: a version of it was published in 1970 in the magazine *Synthesis* (Chaudron 2002). If Cage was preoccupied with this experimental text and its performance, early in 1970, it is possible, even likely, that he brought that preoccupation to the table in performances for Merce Cunningham *Events* (semi-improvisational presentations which collage sections of various dances together, with unspecified musical accompaniment). Unfortunately, Cunningham Company records do not offer any information about what sounds musicians made in *Events*, and recordings of *Events* of this era are a rarity. I have not been able to obtain any from the 1969-70 period which might assist in aurally identifying Cage vocal performances, with or without Tudor's *Rainforest* processing.

The suggestion that Cage was exploring his *Mureau* vocal technique in *Events* around that time, and that David Tudor was making use of Cage's voice as input for his *Rainforest 1* collection of loudspeaker-objects, is, however, corroborated to some degree by both Gordon Mumma and Merce Cunningham. Mumma (2001b) says that "John did do some "singing" and "chanting", notably in the *Event #24* at the University of California Berkeley's Zellerbach auditorium, in 1970" and that

What David, John and I did in the various MDCDC *Events*, was never called *Rainforest* (nor as individual composers did we use titles of our individual works, nor did we perform them as such, in the *Events*). But David did, indeed, use his RF equipment in some of the *Events*. It was a matter of exploration/development. [but] I don't recall any performance of RF with only voice material (Mumma, 2001a).

While researching these *Event* performances at the Cunningham Dance Foundation in 2001, I happened to meet Merce Cunningham (otherwise unavailable for interviews), so took the opportunity to ask him directly about any remembrances of John Cage vocalising through Tudor's *Rainforest* loudspeakers as part of *Event* performances. He replied in the

general affirmative that this had indeed occurred during the 1969-70 period, but was unable to recall any specific instances.

Another possibility exists which is also consistent with the lack of documentation of *Rainforest 2*. The Cunningham Company's European tour of 1970 included a new dance entitled *Signals*, which was premiered in Paris on June 5, 1970. The music for this new work was not a commission given to a single composer, but instead (perhaps taking the cue from *Events*) was credited to Cage, Tudor and Mumma together. The musicians' names, as presented in the programme book, were rotated for every Cunningham engagement, thus reinforcing the communal/cooperative nature of the music creation. Cage, quoted by Charles (1981, 127), said of this arrangement, "Mumma, Tudor and I play independently but at the same time. [...] We each maintain the freedom to form our own plans independent of the other two. We each have enough confidence in the other two to know that it will work". The title of the work on its first performance was *First Week of June*, simply identifying the general time of the premiere. "For a title we use the months and the weeks", said Cage. "It will be 'the second week of April,' or 'the third week of March.'" (Cage quoted in Charles 1981, 127) The "free" nature of the music for this dance, akin to that which was produced for *Events*, suggests that it would have been an ideal workshop for exploration of new ideas. Perhaps *Rainforest 2* was "hidden" inside a performance accompanying Cunningham's *Signals*, but this is pure speculation.

Is *Rainforest 2*, then, a "real" version of the piece? We may assume that David Tudor did at some point perform options two and three from his list in Figure 3-2, with John Cage providing vocal input, although the exact times and places of these collaborations cannot be pinpointed. But Tudor himself seems at one time to have thought little of claiming these options as a distinct "version", requiring a distinct title. We can judge this not only from the lack of documentation, but also from the way it was apparently glossed over in a 1972 note regarding the history of *Rainforest* to that point:

R.F., an assemblage of electric transducing instruments which alter any input signals according to the different resonating characteristics of various physical materials.

The work is open at both input and output.

Its 1st version (68), used specially constructed signal generators as input, with eight instruments.

the present version (72) employs four instruments, with a matrixed output distribution system (Tudor 1972a).

On the 1972 tour, when Tudor was performing with John Cage's simultaneous chanting of *Mureau*, the title of Tudor's accompanying piece in each programme was given simply as an unnumbered "*Rainforest*". And in a handwritten note circa 1974, Tudor (1974b) refers to the large group version of *Rainforest* (conceived in 1973 and conventionally known as *Rainforest 4*) as "RF III". It appears that Tudor took some years to clarify in his mind what the important "stages" were in the history of *Rainforest*, and that the "second stage" did not immediately stand out as a discrete entity, but rather was felt to be so connected to the first version of *Rainforest* for dance, and growing so seamlessly out of situations encountered on tour with Cunningham, that it was in a sense overlooked.

Looking at Tudor's *Rainforest* options list (Figure 3-2) today, the brief descriptions of vocal-source "version(s)" seem an invitation to experiment. In recent discussions (2005) among Tudor's colleagues and friends about continuation of his work, it has been mentioned that, apart from new performances of the versions of *Rainforest* which are better-known, the two options for vocal input ought to be seriously considered (Kuivila 2005). The absence of concrete information about how these were realized historically is, perhaps, only an added incentive.

Chapter 4

THE PEPSI PAVILION (1970) AND RAINFOREST 3 (1972)

4. Various taped materials used as input. Limit these to two at any given time, distributed among the eight channels.

Fourth option for performance of *Rainforest*, corresponding to *Rainforest 3* (Tudor 1968).

David Tudor's involvement with the Pepsi Pavilion at the 1970 World's Fair in Osaka, Japan, and his development of *Rainforest 3* are closely linked, thus it is useful to examine his work with the former before moving on to consider the latter.

The Pepsi Pavilion

In January 1971, following the 1970 World's Fair, two identical time capsules were interred beside Osaka Castle. Buried one below the other, at 11.4 and 7.5 metres, the uppermost to be opened every 100 years and reburied, and the lower of the two not to be opened for 5000 years, each contains 2098 items exhibited in the Matsushita Pavilion during the fair and categorised as related to Natural Science, Social Science, The Arts, and Miscellaneous. One subsection comprises recordings of "animals and birds in danger of extinction" and another includes recordings of works by Stockhausen, Boulez and Cage (Matsushita Electrical Industrial Co., 1996). The theme of the fair was "Progress and Harmony for Mankind" and the fair's programming reflected a concern to present mankind as part of a global equilibrium, in retrospect weighted somewhat unevenly in favour of the humans. For example, the Japan Automobile Manufacturers Association, Inc. presented the "Automobile Pavilion" which included a 12-metre high piece of sound sculpture by Hiroshi Teshigawara entitled *Engine Musical Instruments*:

This art work was made of parts of 60 automobiles. When it was activated, the spectators could hear sounds including electronic music which had been produced with the use of automobile engines, mufflers and gears. The sound of automobiles on the road was added to this and echoed to all parts of the Pavilion, as a prelude of the exhibit theme, "The World of Rhythm" (Osaka World Exposition 1970: Automobile Pavilion).

An approach to providing visitors with a memorable experience, shared by numerous pavilions, was to envelope them in artificial environments. For instance, in the Fuji Group Pavilion,

[...] visitors went from complete darkness into what the sponsors called a total experience [...] a 15-minute film depicted various activities and thoughts of mankind [...] Slide projectors coordinated with the movie by computers flashed 168 pictures on the entire inner surface of the dome. The pictures showed images of mankind from infancy to old age, nature from micro-cosms of Mother Nature to the macrocosm of space [...] (Osaka World Exposition 1970: Fuji Group Pavilion)

In the Takara Group's "Beautilion" (theme: "The Joy of Being Beautiful"), "the visitors in the seats, which gradually elevated for about two meters, heard sounds and watched pictures shown on 12 globular screens on the ceiling", accompanied by music by Toshi Ichiyanagi in which "standard classic and popular music pieces were mixed with natural sounds, sounds of machinery and other non-music sounds through the medium of electronics" (Osaka World Exposition 1970: Takara Beautilion). 360-degree screens and sound systems were also employed in the Toshiba Pavilion (theme: "Light for Man"), the planetarium of the Sumitomo Pavilion ("Familiar Fairy Tales of the World"), the Australian Pavilion ("Australian Contribution to Progress and Harmony for Mankind"), and others (Osaka World Exposition 1970: Pavilion Index).

Elaborate surround-sound systems were in wide use: the West German Pavilion's theme, "Gardens of Sound", was impressively enacted by Karlheinz Stockhausen and other West German composers working in a spherical auditorium with a network of around 500 loudspeakers; Stockhausen presented almost daily concerts between March and June (Osaka World Exposition 1970: German Pavilion). Iannis Xenakis presented a newly commissioned 12-channel piece *Hibiki Hana Ma*, diffused through 800 speakers at the Japanese Steel Pavilion (Zvonar 2003).

Outside, Takehisa Kosugi and others were commissioned to make outdoor environmental sound compositions for the Fair's Festival Plaza, while passersby at the Swiss Pavilion heard

[...] electronic music produced by six-channel sound reproduction equipment and sent through 104 speakers [...] situated seven, ten and twelve meters above the ground. The sound equipment, called the Sonolization Music System, used endless tapes [...] the sounds including birds' twittering were intended to create an atmosphere of the beautiful nature of Switzerland. (Osaka World Exposition 1970: Swiss Pavilion)

The USA Pavilion featured a "New Arts Exhibit" showing works by 24 artists selected from the "Art and Technology" project of the Los Angeles County Museum of Art, including Andy Warhol and Robert Whitman. A project which began in 1966, paralleling E.A.T. in some of its goals, the "Art and Technology" initiative involved 76 artists, and culminated in an exhibition at LACMA in 1971. Artists were invited to submit proposals to work with specific corporations which would support creation of an artwork; strangely, none of the 76 artists invited were women (Tuchman 1971).

Nearby, however, another site functioned—for a short time—as a sort of alternative art pavilion, with Experiments in Art and Technology orchestrating and David Tudor as a key player.

Tudor became part of this project as early as September 1968, following E.A.T. founder Billy Klüver's receipt of an initial grant of \$25,000 from Pepsi-Cola International, towards development of ideas for a Pepsi Pavilion for Osaka. Klüver negotiated with Pepsi an "absolutely free hand" for E.A.T., guaranteeing Pepsi would not seek to influence the Pavilion's design and construction (Lindgren 1972, 10-11). John Pearce, the coordinating architect for the Pavilion, wrote that in his initial meeting with E.A.T.'s artists, they "immediately declared themselves to be 'anti-Expo' ... the best pavilion would be no pavilion at all" (Pearce 1972, 256).

David Tudor took on the task of conceptualising a sound environment for the interior of the Pavilion, and proposed that it should be thought of as a re-programmable instrument. Early concepts of what might happen were written up by E.A.T. in the document "Live programming for the Pepsi Pavilion" (E.A.T. [undated B]), which suggested that

Special events will be held in the pavilion. ... Well-known personalities will be asked to appear in the Pavilion and use the light and sound system to make special programs: an astronaut, Stirling Moss, Joe Namath, The Beatles, Duke Ellington, Allen Ginsberg, Dustin Hoffman, Sidney Poitier, Andy Warhol, and corresponding Japanese celebrities.

None of these celebrities ever appeared at the Pavilion, however.

Tudor proposed a sound modifier console for the central domed space (Lindgren 1972, 49) and involved his Cunningham company colleague Gordon Mumma to design it (Mumma had of course been a co-performer with Tudor for the dance version of *Rainforest*, since its first performance in the spring of 1968). The sound modifier console eventually consisted of eight processing channels (reduced from the 20 channels which Tudor desired), which received mixed signals from a combination of: 16 reel-to-reel tape decks; 16 microphone inputs; sinewave, squarewave and pulse generators; and an LP record player (all of these sources selected in real-time using a switching system controlled by punched-paper tape). These fed into an audio switching system (separately programmable with punched-paper cards) that sent the 8 processing channels to a matrix of 37 speakers arranged in a rhombic grid. Sound programs could consist of lines (sound switched from speaker to speaker in linear patterns), points (sound originating from a single speaker, switchable to any other speaker), and "immersion, or environmental sound" in which "the effect is much like standing in a wood, or on a street, where sounds come from all directions" (Garmire 1972, 189-190). These effects were part of Tudor's input to the design process: early on, he had proposed sounds that would move "so that the listener would have the impression that the sound was somehow embodied in a vehicle that was flying around him at various

speeds, from so slow that the motion would be just barely noticeable, to so fast that again the ear would not be able to detect motion" (Lindgren 1972, 55).

Within Mumma's sound modifier itself (see Figures 4-1 and 4-2), each of its eight channels offered frequency and amplitude modulation, and highpass filter processing, with sixteen manual control points and the possibility of taking the output of one modifier channel and using it as input to another (Mumma 1972). This opened up the possibility of creating electronic feedback systems, turning the sound modifier console into a sound producer .

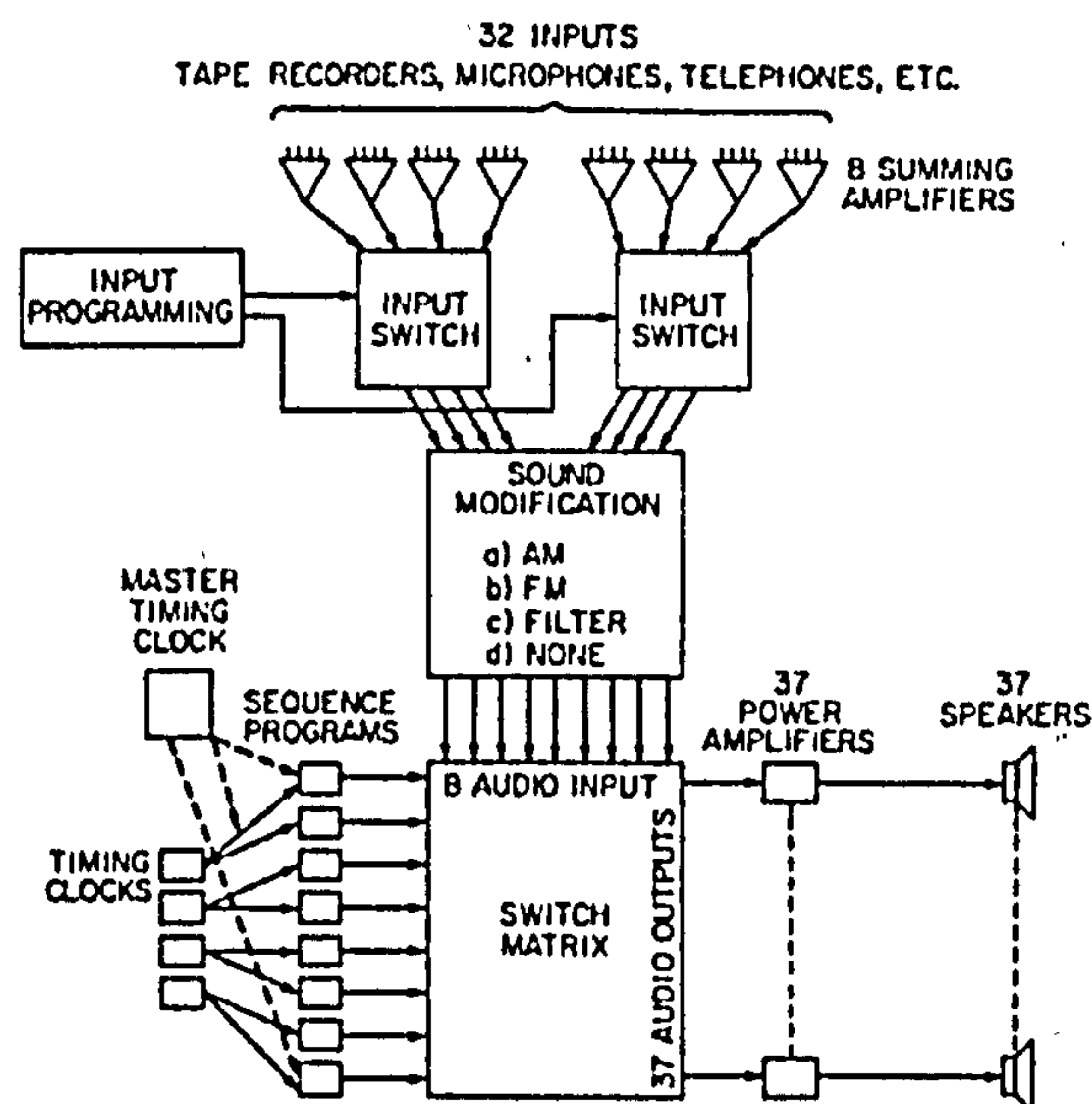

Figure 5. Sound system block diagram.

Figure 4-1. Block diagram of the Pepsi Pavilion sound system (Garmire 1972, 191).

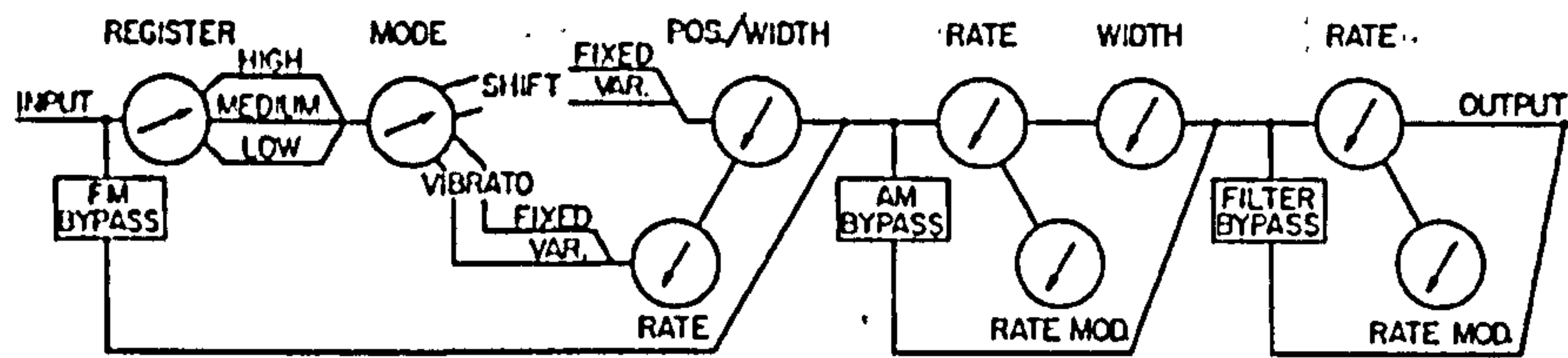

Diagram of one channel of sound-modifier console.

Figure 4-2. Control layout for one of eight sound modification channels on the Gordon Mumma-designed Pepsi Pavilion console, showing FM, AM and highpass filter sections (Mumma 1972, 239).

Whether or not the console was designed with this use in mind, Tudor employed the technique extensively in *Pepscillator*, one of nine programs he developed for the Pavilion. Of the other eight, one entitled *Microphone* was made with acoustic feedback created by shotgun microphones in combination with programming that switched speakers on and off, causing bursts of sound. The other seven programs employed source audiotapes from a large library collected for the Pavilion, which were processed and distributed with the console.

In the document "Live Programming for the Pepsi Pavilion" (E.A.T. [undated B]), a note was made that "Tapes are now being collected of noncopyrighted sounds: brain waves, heartbeats, earthquakes, the earth, fish, animals, factory and street sounds, etc. The sounds are continuously repeated". An appendix to the document states that by February 1970, over 500 sounds had been collected. Geographer Peter Poole and E.A.T. assistant Ritty Burchfield coordinated collection of the sounds, which were subsequently excerpted, looped and edited into 45-minute monophonic reel-to-reel tapes by Tudor and Burchfield.

The recordings were collected from numerous sources and represent a wide spectrum of field recordings, ranging from bio-medical documentation of neural and circulatory system activity in humans and other animals, to renderings of ultra- and infrasonic sources such as bats

and earthquakes and geomagnetic activity, to recordings of birdsong, whalesong, insects, and human activity such as ships' horns and alarm signals. The recordings were offered as a resource to artists invited to submit programming proposals to E.A.T.: for instance, Kyoshi Awazu's proposal requests "Twittering of wild birds or rattling and whistles of steam trains are preferable for sound effects. Jet plane sounds will also be desirable". Masanobu Yoshimura's proposal includes "(1) Number-counting in different languages ... (2) Flowing, running and hissing sounds (concrete sounds plus electric sounds)" (E.A.T. 1969, 315-316).

Although proposals were accepted from at least 34 artists from the USA and Japan, only ten were able to present work before April 25 1970, when Pepsi effectively fired E.A.T. as managers and artistic directors of the Pavilion, due to cost overruns and general doubt that E.A.T.'s approach would lead to any advertising benefit for the corporation. Pepsi gave E.A.T. a matter of hours to clear out of the Pavilion and head back to the USA, and made it clear that the programming materials—tapes and hardware—were to remain behind. Peter Poole (2001) remembers being woken by a call in the wee hours from artist Robert Whitman saying "Gotta get the tapes out!" and subsequently being accosted by security guards as they threw tapes over the Pavilion perimeter fence. Ritty Burchfield (2002) recalled that she helped smuggle more tapes out of the Pavilion a few at a time, hidden in the cleaners' carts.

David Tudor created a total of nine programs for the Pavilion's sound system, four of which he considered substantial enough to be included in his catalog of works as the "Four Pepsi Pieces": *Pepsibird*, *Anima Pepsi*, *Pepscillator*, and *Microphone*. What is interesting about these pieces is the divide in their methods of production, which reflects Tudor's two primary approaches throughout his electronic music career.

Pepsibird and *Anima Pepsi* (as well as other programs for the Pavilion which are not included on Tudor's list of compositions and have work titles in his notes such as "4: Space" and "5: Animals" (Tudor 1970b)) drew upon the Pavilion library and used the sound modifier console to process

and distribute a selection of field recordings; these field recordings became the central resource for *Rainforest 3*, two years later.

The other two of the "Four Pepsi Pieces" do not use source tapes at all; rather, all the sounds in these compositions are created by feedback: electronic feedback in the case of *Pepscillator* and acoustic feedback in the case of *Microphone*.

Pepsibird

In Tudor's written description of *Pepsibird* (Tudor 1970) it is a "live mix of ten sourcetapes" of which seven are laboratory recordings of neural activity (cats and humans), two are 'modified' and/or speed-altered field recordings of nightjar calls, and one is a transposition of ultrasonic signals from bats into human hearing range.

(8) cat's eye	(13) * EEG
(9) nerves firing	(23) * Alpha waves AM-FM
(17) * bats	(27) Modified Nightjar slow
(21) * brainwaves slow	(28) Modified Nightjar regular
(22) * brainwaves regular	(26) Demodulated Alpha

(Tudor 1970)

The number in parentheses indicates the number of the tape as catalogued by Tudor and Burchfield. Source tapes marked with an asterisk "may be modified through the console channels", i.e. processed with amplitude and frequency modulation, and highpass filter (each of which could be used with fixed settings or set to respond to the input amplitude of a signal).

Seven programs for sound movement amongst the 37 speakers are given: "small circle, great circle, large rhomboid, single overhead, spiral, small triangles, small ovals", with the instruction to "Associate the sourcetapes with the speaker patterns, distinguishing between constant or intermittent sound materials. Maintain the identity of each sound - if

modified through the console, it should not occur also in unmodified form. No more than five tapes sounding simultaneously" (Tudor 1970).

This is a very useful description of Tudor's general approach to performance, beyond the specifics of the Pepsi Pavilion situation. His tactic of contrasting movement of sounds among multiple speakers with single-speaker point sounds, either simultaneously or (very effectively) in sudden contrast, has been noted by Ron Kuivila (personal communication, March 1 1998) among others. The concern for clarity and separation of layers of sound can be traced back to his initial career as a pianist, when as John Cage ([undated B]) described it, Tudor laboriously developed the ability, not yet approached by others, to give

each attack in a rapid succession of many its own dynamic character. He took the principle underlying Klangfarbenmelodie [...] and applied it to the relation between himself and his instrument: differences of energy, of distance and speed of attack, and extension of the understanding of the mechanism of keys, hammers, strings.

Other colleagues noted the same facility, for example David Behrman, who wrote of a 1957 piano performance of works by the "New York School" of Feldman, Brown, Wolff and Cage, as well as Stockhausen and Bo Nilsson, that "whether the music was sparse or dense, every individual note had its own life, its own character, timbre and idiosyncrasy. And that was true even when he was producing extravagant bursts of hundreds of notes in a few seconds" (Behrman 1997).

Anima Pepsi

The second of Tudor's "Four Pepsi Pieces", *Anima Pepsi*, differs from *Pepsibird* primarily in its selection of source material. Tudor's notes list the following Pavilion tapes:

(5) mosquitoes
(6) monkeys
(12) insects
(19) animals
(20) animals

(29) fly on flypaper modified
(30) wasp chewing modified
(31) beetle walking modified
(32) Funny Tape

(Tudor 1970a)

This selection differs from that of *Pepsibird* in that all are straightforward field recordings of animal and insect activity (although the highly amplified sounds of "wasp chewing" and "beetle walking" are, like many of the *Pepsibird* source tapes, revelations of activity normally too quiet to be observed, made audible through technology. "Funny Tape" is a recording of human activity including whistling, "boing" sounds that might have been made with a jaw harp, and odd vocalisations which sometimes sound like gargling.

The title of the piece seems to be a parody of *anima mundi*, "the soul of the world", a term which would have been familiar to Tudor from research in occult and mystical writings and practices. In particular, he would likely have known the writings of Madame Helena P. Blavatsky, cofounder in 1875 of the Theosophical Society, precursor to Rudolf Steiner's Anthroposophical Society founded in 1924, of which Tudor was a member from 1957 (Kahn 2001).

Blavatsky referred to the *anima mundi*, formed by the *akasha* (a Buddhist term referring to "both space bounded by the material world, and a form of space which is infinite and indefinable, which contains the material world" [occultopedia.com]), as being identical to "'Maha-Atma, Brahm, the Spirit of Life'; these [...] appellations are identical with the Universal Soul, or *Anima Mundi*, and the Astral Light of the Theurgists and Kabalists" (Blavatsky 1896). *Anima Mundi*, as used by Blavatsky, refers to "the soul and animal spirit of mankind" (Blavatsky, *Helena Petrovna (1831-91)* [Occultopedia]), and Tudor's composition, combining sounds from the animal and insect kingdom with incongruous, not to say ridiculous, human noises, describes "the soul of Pepsi".

The nine source tapes are to be distributed to the speaker matrix as for *Pepsibird*, varying speaker clocking rates and employing sound modifiers "freely [...] modifying characteristics can be changed discretely or within the durations of the sounds" (Tudor 1970a).

Rainforest 3

In February 1971, Hans Otte of West Germany's Radio Bremen wrote to John Cage at his home in Stony Point NY, with an invitation to perform the following year. The event was to be presented as part of Radio Bremen's *Pro Musica Nova* series and broadcast throughout Western Europe via the European Broadcasting Union. The invitation was not for Cage alone; Otte hoped that David Tudor could accompany Cage to Europe for a duo performance of Cage's works, as they had done so many times in the past. In Otte's correspondence, Tudor was automatically included in the invitation extended to Cage:

[...] we have been granted 10,000 DMs (c. \$4,000) for the express purpose of inviting you, and of course David Tudor, from the USA to North Germany for the event... Please give me your answer as soon as you can. [...] Meanwhile, I would be glad if you would convey my kindest regards and best wishes to David Tudor. [...] (Otte 1971)

From this letter we can see how strongly Cage and Tudor were still identified in Europe as a performing duo, stemming from their two decades of concertising together there, with Tudor firmly in the position of celebrated performer. Tudor had not yet appeared at a European venue as a composer in his own right, save as part of his collaboration with Robert Rauschenberg at the Moderna Museet in 1964 (in which he performed his retroactively identified first composition, *Fluorescent Sound*) and with the Cunningham Company performing *Rainforest 1* for dance (there were ten performances of Cunningham's dance *RainForest* in Europe in 1970).

Cage quickly replied to Otte that he would be glad to come but that Tudor ought to be approached separately and invited as a composer in his own right (Cage 1971a). Cage's insistence that Tudor required his own invitation, arising from acknowledgement of his recently claimed identity as a composer—in effect, an insistence that Tudor receive equal billing to Cage—is evidence of the respect he had for that identity. Cage ([undated C]) wrote around the same time,

Nowadays, Tudor rarely plays the piano. His work is in the field of electronics [...] He invents components and sound systems of great originality. He solders and constructs them. He keeps abreast of the developments throughout the world in the field of electronics. He makes new loudspeakers free of the constriction of high fidelity.

Interestingly, Cage is remembered as also having occasionally expressed frustration with Tudor's departure from the piano, even insisting he didn't understand Tudor's desire to be known as a composer (L. Kuhn, personal communication, May 10 2002). In Cage's communication with Otte, something of this frustration shows: "We are the best of friends but we don't give concerts together as we did formerly. Recently (Oct. '70) I gave performances in Paris without him and I was not happy with the way the music was played" (Cage 1971a).

It appears that although Cage put Tudor forward as a composer, he did in fact ask Tudor if he would appear in Bremen as an interpreter: following on his first reply to Otte, Cage sent another Note-O-Gram:

I have spoken to David Tudor. He would be willing to collaborate, but I'd propose that you also present some of his work, if you engage him. You can write to him at Stony Point, NY 10980 ... I would be pleased (if he is willing) to have all 5 carillon works played by David. (Cage 1971b)

Almost three months later, Cage wrote to Otte once again to say "I've had a good talk with David Tudor" about their collaboration, then briefly setting out the details of the performances they would do in May 1972.

What we offer for the European transmission is: MESOSTICS RE MERCE CUNNINGHAM (my work, which I would vocalize) with an as yet untitled work by David Tudor (electronic). For this we need three channels (3 separate amplification systems). For the concert (3 hours) we offer MUEAU [sic] [*MUREAU* was first performed on March 12 1971, as a solo, at New York University, where it was entitled *MUEAU IC SICLECTRONE RETHOR*, an anagram for *Thoreau re Electronic Music*] (my work which I would vocalize) with RAINFOREST (David Tudor's electronic work). For this we need 8 separate channels with speakers around the space, hopefully in a situation where the audience is free to move around, with of course some seats for those who need them. (Cage 1971c)

There is no mention of the works for carillon, but Cage follows with the ambiguous comment, "This solution pleases me for it in no way interrupts David's work". Presumably this refers to the "performed installation" nature of the three-hour concert: Tudor would be able to make music continuously without the artificial imposition of time structures. The comment could also, however, be understood as referring to the entire situation as it came out of Cage's "good talk" with Tudor: the collaboration of the two friends was able to occur in a manner that would not require Tudor to direct his energies away from work that was all his own. Whichever reading might be taken, the source of Cage's pleasure is clearly that Tudor's self-expression will be permitted to flourish. The "as yet untitled" work of Tudor's came, eventually, to formally be called *Untitled*, perhaps more by default than intention.

The simultaneous performance of two allegedly unrelated streams of work was of course the foundation of Cage and Cunningham's collaboration, and Cage in 1971 was full of the experience of producing *HPSCHD* in May 1969 with Lejaren Hiller at the University of Illinois: a massive space full of a simultaneity of musical and visual events. He wrote to Otte that

"What I now prefer to concerts are events uninterrupted by intermissions etc." (Cage 1971c).

By the end of September 1971, details for the collaborative concerts at Radio Bremen had been finalised, thanks to a flurry of communications between Otte and Mimi Johnson. Johnson had been working for Cage as personal secretary since early fall 1971 and in early 1972 founded Performing Artservices, Inc., a non-profit management organisation for avant-garde artists. This New York-based venture mirrored the creation in 1971 of Artservices International in Paris, by Bénédicte Pesle, to promote the work of Merce Cunningham. Pesle had known Cunningham and followed his work since a student in New York in 1951 (Frétard 2001), and Johnson had worked in Paris with Pesle at the Iolas Gallery in 1971 before returning to the USA. Johnson (2003) has said that her model for establishing Artservices in New York was the efficacy that Jean Rigg was exhibiting at the time in managing the Cunningham Company.

The two Artservices offices, while not strictly speaking branches of a single organisation, shared a desire to promote experimental performance, and Johnson (1971) wrote at the beginning of November 1971 that "I work very closely with Bénédicte Pesle in Paris, and she is au courant and actively interested in John and David's tour".

A tour was indeed in the planning; following the Radio Bremen invitation Johnson immediately wrote to numerous other European presenters, all of whom responded warmly and some of whom were able to offer performances for Tudor and Cage. Some of these were occasions for the two to collaborate as in Bremen; other dates were invitations for Cage as composer, with Tudor accompanying. Solo dates for Tudor were not explicitly solicited by Johnson, nor were any offered.

The final schedule for the tour (as detailed in the Appendix to this thesis) included dates not only for *Rainforest/Mureau* and *Untitled/Mesostics*, but also *HPSCHD* in which Tudor performed as one of seven harpsichordists,

and a new Cage work *Birdcage*, accompanied by a new Tudor piece *Monobird*, a reworking of *Pepsibird* from the Osaka pavilion.

Rainforest/Mureau received the greatest number of performances (five), *Untitled/Mesostics* was only performed twice, and the only occasion on which the two were presented in one evening was their Royal Albert Hall performance in London on May 22.

In addition to these dates, Tudor accompanied Cage on visits to London (Cage lectures at ICA, May 10-11), The Hague (performances of Cage's work in the Holland Festival, May 13-14), and York, UK (Cage lectures/performances May, 23-24). Tudor himself did not perform on these occasions. Tudor and Cage also took a break from June 8-25, staying with Bénédicte Pesle at her house in Pontpoint, France.

The version of *Rainforest* presented on the 1972 tour differed significantly from previous realisations. A draft description (seen already, in the previous chapter) reads:

an assemblage of electric transducing instruments which alter any input signals according to the different resonating characteristics of various physical materials.
The work is open at both input and output.

Its 1st version (68), used specially constructed signal generators as input, with eight instruments.

the present version (72) employs four instruments, with a matrixed output distribution system. input signals have been processed from materials acquired from bio-medical & natural scientific sources (Tudor [undated C]).

To reiterate, this note does not mention the experiments with Cage circa 1969-70 which Tudor later retroactively dubbed *Rainforest 2*.

The physical size of this version was reduced by at least half compared to the 1968 version for dance, to make it possible for Tudor to tour it without

support. Only four small loudspeaker objects were employed; instead of numerous signal generators which were bulky to carry, two portable cassette tape decks were the source of signals. The signals themselves were recordings from the tape library which had been rescued when E.A.T. was removed from the 1970 Pepsi Pavilion project.

The soundworld of the Pepsi recordings is as 'electronic' as the chirping oscillators employed in the earlier *Rainforest*; all have their origin in the biological world, however, and exist as field recordings of different kinds, mostly made under controlled conditions (see Figure 4-3).

ALPHA AM-FM NORM	mod EEG norm
alpha am-fm slow	mod EEG slo
bat 1 7/8	mod n. jar slow
beetle walking	modified night jar
BR WAVES SLO	monkey slow
brain waves	mos. t.t. normal
brainwaves	mosquito test tube slow
cat's eye slow	mosquitos
demodulated alpha	NERVES FIRING
earth vibes long	wasp chewing modified
EEG (NORM, SLO MIX)	wasp chewing slow
fly paper modified	
insect slow	

Figure 4-3. Partial list of David Tudor's source tapes for *Rainforest 3*, derived from the Pepsi Pavilion collection. Tudor's Pepsi tapes are included with the David Tudor papers at the Getty Research Institute, Los Angeles.

To say that this collection of recordings originated "in the field" requires a broad definition of "field recording", since the majority of these tapes appear to have been made under laboratory conditions. These include sonifications of animal brainwave and nerve activity—"alpha", "brainwaves", "nerves", "EEG" and "cat's eye" tapes making up almost half of the source tapes available for audition. Highly amplified insect sounds ("beetle walking" and "wasp chewing") and the "trapped insect" recordings ("mosquito" tapes and "fly paper" recording) were also made

under highly amplified, controlled conditions. Two of the tapes are transpositions into the audible range of vibrations above and below human hearing: "bat" and "earth vibes". Though it is not clear under what conditions the "night jar" and "monkey" recordings were made, it seems they are among the few which we might think of as "traditional" field recordings.

The focus in *Rainforest 3* on bioacoustic field recordings is worth considering, because it suggests that this new version of the piece was taking on a much stronger and more literal identification with a real or imagined "rainforest" world of insect, animal and bird sounds. This is quite different from the original version produced for Merce Cunningham, whose avowed aesthetic eschews the literal (though the dance *RainForest* is described by Cunningham Company archivist David Vaughan (1997, 163) as a "nature study"); the recording of the piece's premiere reveals that it is primarily a study in electronic drones. John Driscoll (personal communication 2000), later a primary collaborator in *Rainforest 4*, has said of Tudor's title that it was merely inherited from the title of the dance and was not programmatic.

Judging from the labelling of Tudor's cassettes, many of the field recordings do not appear to have been used directly but have been subjected to various types of processes, first of all speed changes. "NORM" and "SLO" or "SLOW" indicate tapes at original and slower speeds. "1 7/8" is a tape-speed notation also indicating slower playback. In the case of the brainwave recordings, "Brain waves", "BR WAVES SLO" and "brainwaves" are related by speed changes in the ratio 1:2:4, where the first of the three seems to be the original speed recording. In this case, reducing tape speed, and thus transposing its frequency content down as much as two octaves, is a means of revealing complex melodic material which is difficult to parse at the original speed.

The brainwave sonification has several distinct components, pitched low and high (see Figure 4-4). At the fastest playback speed, the lower

component is a warbling pitch around 1 kHz, which deviates by about a semitone. The higher component is a combination of fast-moving warbling pitches with most energy in the region of 4-7 kHz, resembling the sound of an insect swarm. When tape speed is reduced by half, the lower warbling tone takes on a more melodic character and it becomes clear there are two higher pitched tone regions, one in the midrange where two tones oscillate between approximately 1000 and 1300 Hz, and one in a higher register which has the character of a sustained scream at around 2900 Hz, with frequent deviations. These variations in tape speed obviously present extended possibilities for matching with *Rainforest 3* loudspeaker-objects, which may each favour only a restricted range of frequencies.

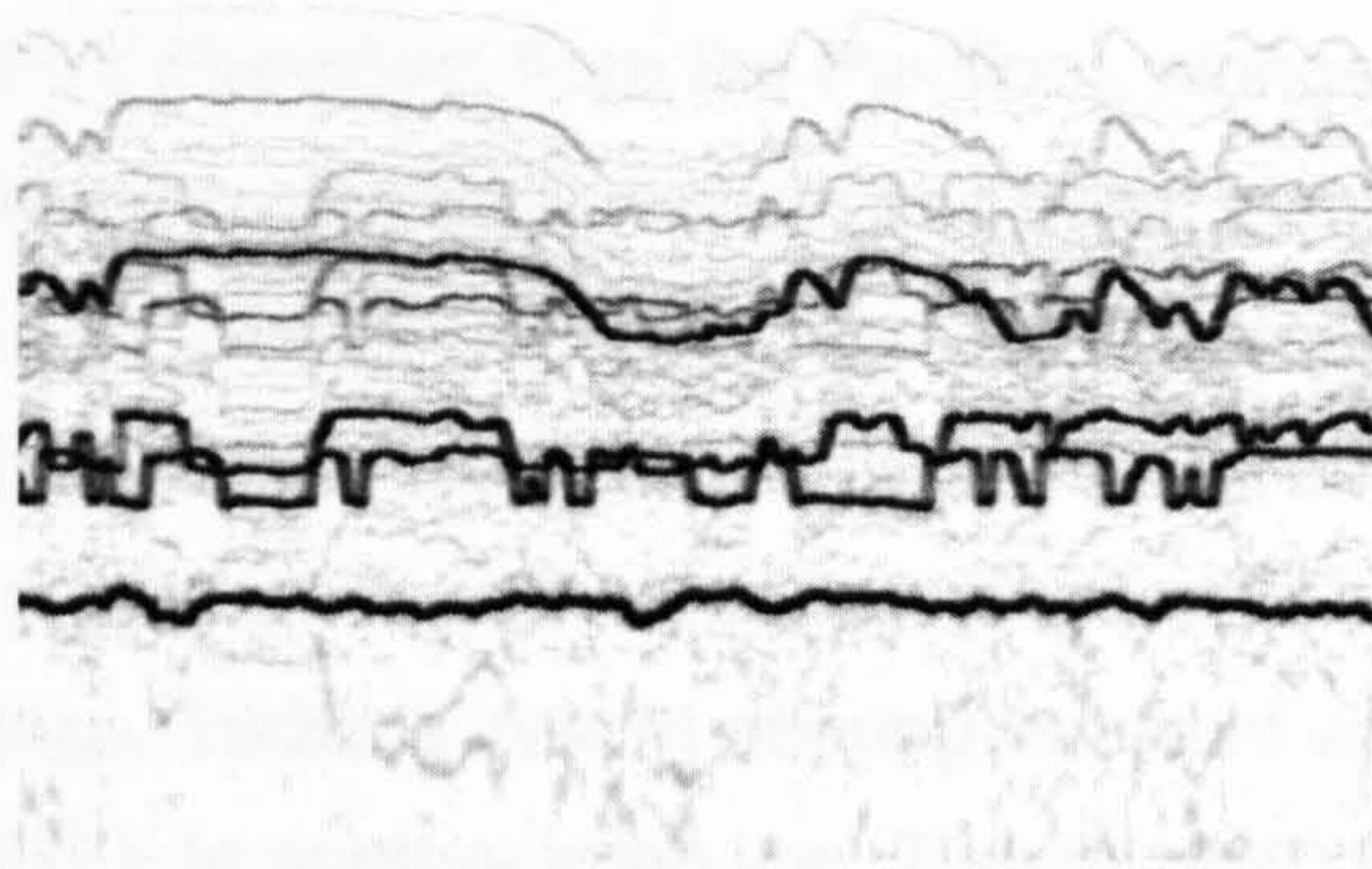

Figure 4-4. Spectrogram of a five-second excerpt of "BR WAVES SLO [225a L]" (brain wave sonification played back at half speed) showing three distinct tone regions.

Other modifications to the field recording source tapes seem to include frequency and amplitude modulation (found in the Figure 4-3 list in "ALPHA AM-FM NORM" and "alpha am-fm slow"), possibly achieved with the prototype of Gordon Mumma's Pepsi Pavilion modulator, which Tudor owned, or actually produced at the Pavilion. A number of other tapes are labeled as "modified", which suggests they may also have been processed with Mumma's Pepsi circuits. The Pavilion console designed by Mumma relied primarily on eight channels of FM and AM modulation circuits, in series with high-pass filters (see Figure 4-1 and Figure 4-2)

(Mumma 1972, 239). Mumma's prototype represented one channel of the Pepsi console, with independent frequency and amplitude modulators, and a high-pass filter.

It has been recognized that frequency and amplitude modulation are central features in the production of bird, animal and insect calls (Beckers *et al* 2003; Suggs and Simmons 2005; Bennet-Clark 1999). There is substantial evidence that Tudor, as a collector of bioacoustic signals for the Pepsi Pavilion, researched these and other topics in bioacoustics as preparation for his work with the Pavilion. Many handwritten references to, and notes on, bioacoustics articles and books, are found in Tudor's papers dating from the Pepsi era. For example, in a study book likely dating from the early 1960s into the early 1970s, we find notes on the "Pepsi piece", *Anima Pepsi*, and the third 1972 tour piece, *Monobird* (following on 1970's *Pepsibird*, from the Pavilion), alongside lists of references to articles on biosound topics, and basic electronic circuits (Tudor [undated C]). Tudor's use of FM and AM processes, when viewed with this in mind, are a reinforcement of his professed connections with the "natural": in applying FM and AM processing to the "naturally" obtained recordings, Tudor is indeed offering "more of what's already there" (E.A.T. 1977). In another interview, Tudor (1989) further elaborates on his relationship to the "natural", in comparison with the approach of Alvin Lucier:

For me, the concept of observation is primary...I need to observe something in a way that I don't put any prejudice. I want to see what it tells me. [...] I want to show it [the work] as something in nature. You know, I don't want to display it, I want it to display itself, you see.

As with the later "sculptural installation" version of *Rainforest* (*Rainforest 4*), the 1972 version performed with the Pepsi tapes is a zone where the boundary between the "natural" and "artificial" becomes determinedly

confused. Tudor situates himself, and his work with electronics, firmly within the "natural", thus the dichotomy between natural and man-made worlds is seen as a false distinction. This echoes the work of early ecologists in the 1920s and 30s, who came to a realization that "nature" did not stand apart from human activity (Cameron 2001). The "electronic ecology" of *Rainforest 3* is an environment where effectively any sound may be introduced. "The work is open at both input and output", wrote Tudor (1972). A 1972 article on Tudor's conversion from pianist to electronic musician is also revealing of his relationship to the natural:

[...] each output mechanism has its own bias. So I must see what its properties are as a natural phenomenon, and not spend my time making it do something against its nature. [...] Nature is a wonderful starting point. If you can learn to look at Nature simply as an observer, then you're off the ground. (Tudor 1972c)

Though the field of possibilities is theoretically wide open, Tudor's choice of source materials for *Rainforest 3* is relatively specific: "Input signals have been processed from materials acquired from bio-medical & natural scientific sources" (alternative wording: "thru bio-medical instrumentation & n.s.s".) (Tudor [undated C]). Of these, Tudor favours recordings in which sounds are ever-changing and yet static. Rhythms (as with the "modified night jar" or "bat 1 7/8" tapes) are only quasi-repetitive, never establishing themselves for longer than a few seconds. What might be called melodic material (as with the warbling tone patterns of the brainwave recordings) is apparently random and non-repetitive as well. These characteristics hold true for all of Tudor's Pepsi sources, and thus link them together regardless of their origin.

Many of the Pepsi sound source origins are non-obvious even when the source tape is heard directly, without the mediation of a loudspeaker-object; but it is the transformative character of the loudspeaker-objects which finally brings the sounds together and makes their origins ambiguous for once and for all. This transformative ability works on

sounds of electronic and acoustic origin such that one might become mistaken for the other. This effect is first explicitly introduced in *Rainforest 3*—the sound sources of *Rainforest 1* are clearly intended to be electronic, and those of *Rainforest 2* vocal—and is an even more important feature of *Rainforest 4*. Any dichotomies between sound sources are finally erased by their acoustic filters, the *Rainforest* loudspeakers, which colour sounds to the extent that they often can no longer be identified as electronic or acoustic in origin.

Tudor's collection of Pepsi tapes is highly distinctive, however, and they define this version of the piece so strongly that to recreate it with other sound sources would in my view be problematic, even if the possibility exists in Tudor's own programme for the piece. *Rainforest 3* was performed only as part of Tudor's 1972 tour with Cage; it was built on source sounds from the 1970 Pepsi Pavilion not only because Tudor merely found those sounds interesting, but likely also because they had not been adequately explored in the context of the Pavilion (due to the early ousting of E.A.T. and its artists). The piece is so clearly defined temporally and sonically that if *Rainforest 3* were recreated using entirely new source material, it would likely stand apart from Tudor's original version so strikingly that it might be due a completely different version number: what identifies *Rainforest 3* as such is in fact the specificity of sound sources, which in most cases may be distinguished even through the colouration provided by the resonant objects. It seems possible that a new version could be constructed by extending those sources (identifying new "bio-medical & natural scientific" recordings (Tudor [undated C])), but that if they were not to be introduced cautiously, the original character of *Rainforest* version 3, determined by the Pepsi tapes, would be absent. The role of *Rainforest 3*'s transduced objects—which have not been conclusively identified—is of far less importance to the identity of the piece than the source tapes.

One note mentioning specific objects and source tapes exists, showing how sources were matched with appropriately resonant objects, but the

objects themselves are not explicitly identified (see Figure 4-5). In this note, we see mention of a plastic object, and a "lid", and two more objects identified only as "SM R" and "L R". Photographs of performances have not illuminated Tudor's use of specific objects. The carnet prepared by Artservices for "David Tudor, European Concert Tour May 5-July 18 1972" is highly detailed for customs purposes, yet includes only one item which is likely to have been a loudspeaker-object: "1 metal plate" is listed among 36 list entries for items in three cases accompanying Tudor as checked baggage. These include the devices needed for both *Rainforest 3* and *Untitled*. Other loudspeaker-objects might have been included as part of generalized entries, such as "three bags spare parts", but this seems unlikely (Tudor [undated]).

Handwritten notes on a piece of lined paper, likely a carnet or customs form. The text is written in dark ink and is organized into several lines, each starting with a label followed by a quantity in parentheses and then a description of the object. The labels are: 'PLASTIC (1)', 'LID (5)', 'SM R', and 'L R'. The descriptions include: 'ALPHA AM-FM NORM (ST) EEG (N, S MIX) (RV)', 'STAIRS - DOOR WATER VIBES DATA NJ NORM (ST) BS', 'DEMOD ALPHA (ST) L', and 'ALPHA FM AM S'.

Figure 4-5. Notes on *Rainforest 3* (rewritten by Matt Rogalsky from Tudor's original) (Tudor 1972g).

Such objects are not found among other items sent ahead by freight by John Cage, though Cage did ship two cartons of slides to Berlin for a scheduled performance of his *HPSCHD* (Artservices papers, John Cage Trust). This suggests that some or all of the loudspeaker-objects used in

the tour might have been located by Tudor in Europe, rather than developed ahead of time and brought with him. What seems clear from the recording of Tudor and Cage's first performance of *Rainforest 3 / Mureau* is that there is a selection of metallic and wooden or plastic objects which provide sufficient variation in response to the available source materials, which are not necessarily intimately related to any one particular object.

Specifications of *Rainforest 3*

Tudor's text description corresponding to *Rainforest 3* in the *Rainforest* "option list" (item 4 of Figure 3-2) suggests that it could or should be realized with 8 loudspeaker objects, at least four channels of conventional amplification of the objects' contact microphones, any number of performers, and simply "various taped materials used as input ... Limit these to two at any given time, distributed among the eight channels" (Tudor 1968). In actuality, the piece was designed as a solo performance to be performed in tandem with Cage's *Mureau*, and the 1972 specifications for the piece which Tudor wrote to be sent ahead to Basel and other venues differ from those in the list. These specifications were first drawn up by Tudor for Artservices on behalf of himself and John Cage, for both *Rainforest 3* and *Mureau* (see Figure 4-6) (Tudor 1972d). For *Mureau*, Tudor specifies four microphones and four monophonic reel-to-reel tape playback machines: the performer (Cage) must have control of microphone and tape playback amplitude, and each microphone should have "different EQ". This approach to performance of *Mureau* was taken by Cage in some solo performances prior to the 1972 tour: each of the microphones could be assigned to a different loudspeaker and spatial effects achieved by moving between the microphones, set in front of Cage on desk stands (on at least one occasion Cage achieved spatial effects in *Mureau* without electronics: a performance at Western Michigan State University on November 17 1972 involved members of the audience who wished to participate as "chanters", so Cage had *Mureau* texts

distributed to them. These participants were spread throughout the theatre).

8 channels - 8 amplifier channels - 8 (or multiple of 8) loudspeakers

4 microphones, each with different EQ
4 tape machines (for playback of monophonic tapes, 3 3/4 ips, 7" reels)

} mixing into 4 of the amplifier channels. gain controls for both microphones & tape machines must be at performance table

other 4 amplifier channels should have line inputs (600 to 1000 ohms)

also required:
1 stereo cassette tape deck (good quality)
120 volt current should be available (approx. 10 amps)

Figure 4-6. List of technical requirements for performance of *Rainforest 3* and John Cage's *Mureau*, drawn up by David Tudor for Performing Artservices, to be distributed to European venues for the 1972 tour (Tudor 1972d).

Tudor's specifications request provision of eight loudspeaker channels, but these are divided into two discrete four-channel systems, clearly indicated by his memo that the microphones and tape machines should be mixed into four of the amplifier channels, while the "other 4 amplifier channels should have line inputs" (from Tudor's setup). The request for a single stereo cassette tape deck was presumably for Tudor's use, playing back his cassette dubs of Pepsi source material.

In the same folder with Tudor's technical notes is an unusual typescript description from Cage of his requirements for *Mureau*, which reflect the way his half of the collaboration would in fact be performed:

MUREAU

My 3 tapes are monophonic and run at 3 3/4"/sec. I would myself need a microphone, there should be 4 separate channels and appropriate amplification for each (appropriate to the space). The mike should be on a table at which I will sit, and the 3 tape recorders should be within my reach so I can turn them on and off. I will need time with your technicians to test the set-up. Please..... [sic]

(Cage 1972)

Tudor's thoughts about the *Rainforest* to accompany *Mureau* certainly went through significant revisions: a sketchbook full of variations on *Rainforest 3*'s technical setup exists (Tudor [undated C]), in which many possibilities are explored including complex mixing schemes and use of filters to modify sounds returning from the loudspeaker-objects' contact microphones (see Figure 4-7 to 4-9). Tudor also appears to have attempted to incorporate the one-to-four channel "sound stirrer" built for him by Lowell Cross, to pan sounds among four loudspeakers. An interesting feature of this notebook, which connects his work at the Pepsi Pavilion with *Rainforest 3*, is Tudor's use in sketches of the type of notations for potentiometer movements which were also used in his diagrams for the "Four Pepsi Pieces" (Klüver *et al* 1972, colour plates). The notations are not uncommon in technical drawings but do not appear elsewhere in Tudor's score diagrams. Another feature of the notebook is a page of five complex routing diagrams, each with what seems to be a count for the number of patch cables required: possibly an exercise in finding the optimum level of flexibility with minimum complexity, in order to reduce setup time (see Figure 4-9). It is clear that, at this stage, Tudor was already working within a framework of only four loudspeaker-objects,

rather than the eight required for the *Rainforest* which accompanied the Cunningham dance (it is worth remembering, though, that the dance version was designed for two performers, each working with four objects). Another preliminary diagram indicates that Tudor considered running four cassette tape decks of source material, rather than the two he eventually settled upon (see Figure 4-8). Again, this may have been a streamlining, a reduction of complexity, or it may be that Tudor experimented in early stages with four monophonic cassette decks and later substituted the two stereo decks, all the while working with the idea of four monophonic streams of source material.

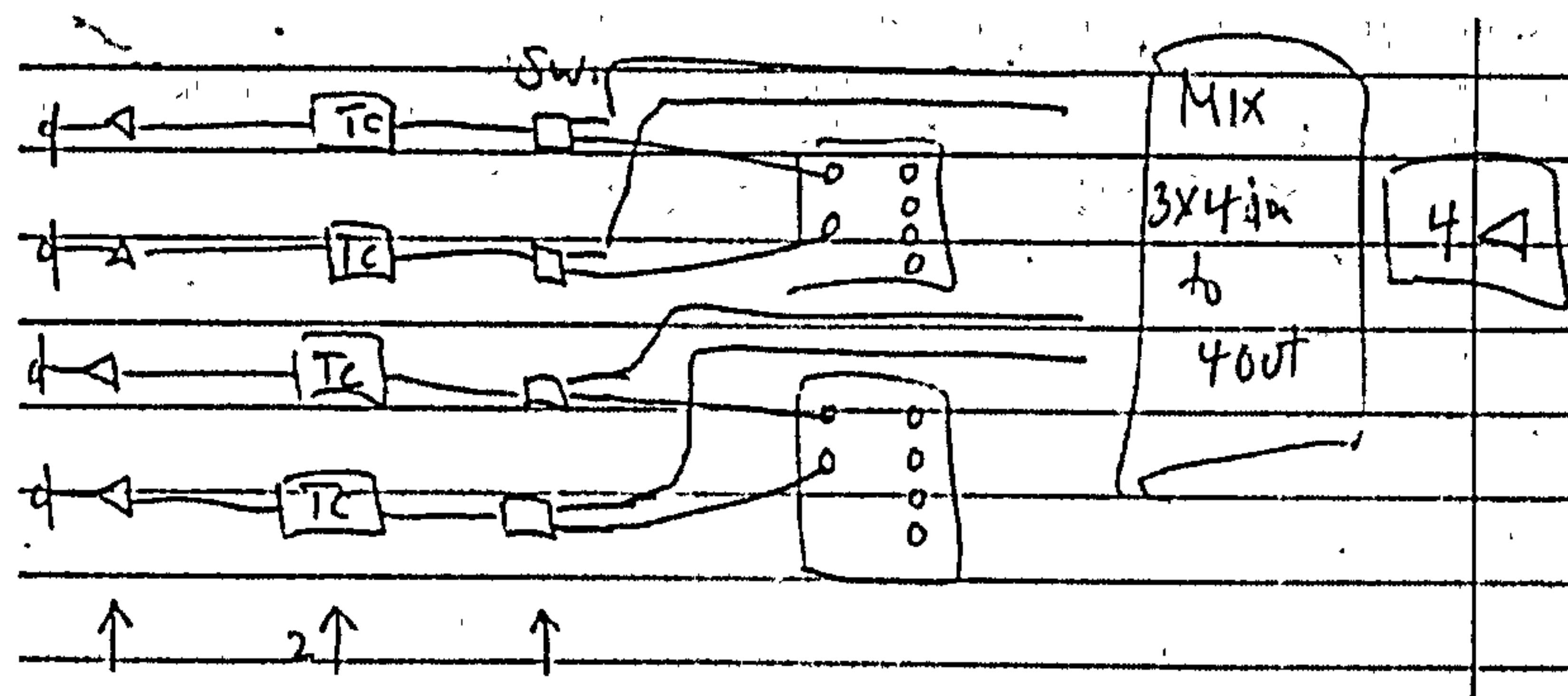

Figure 4-7. Preliminary sketch for routing of signals returning from loudspeaker-objects' contact microphones. "TC" probably refers to TEAC four-channel mixer. "SW" refers to one-input, two-output switch boxes used to redirect the contact microphone signal (original Tudor diagram) (Tudor 1972h).

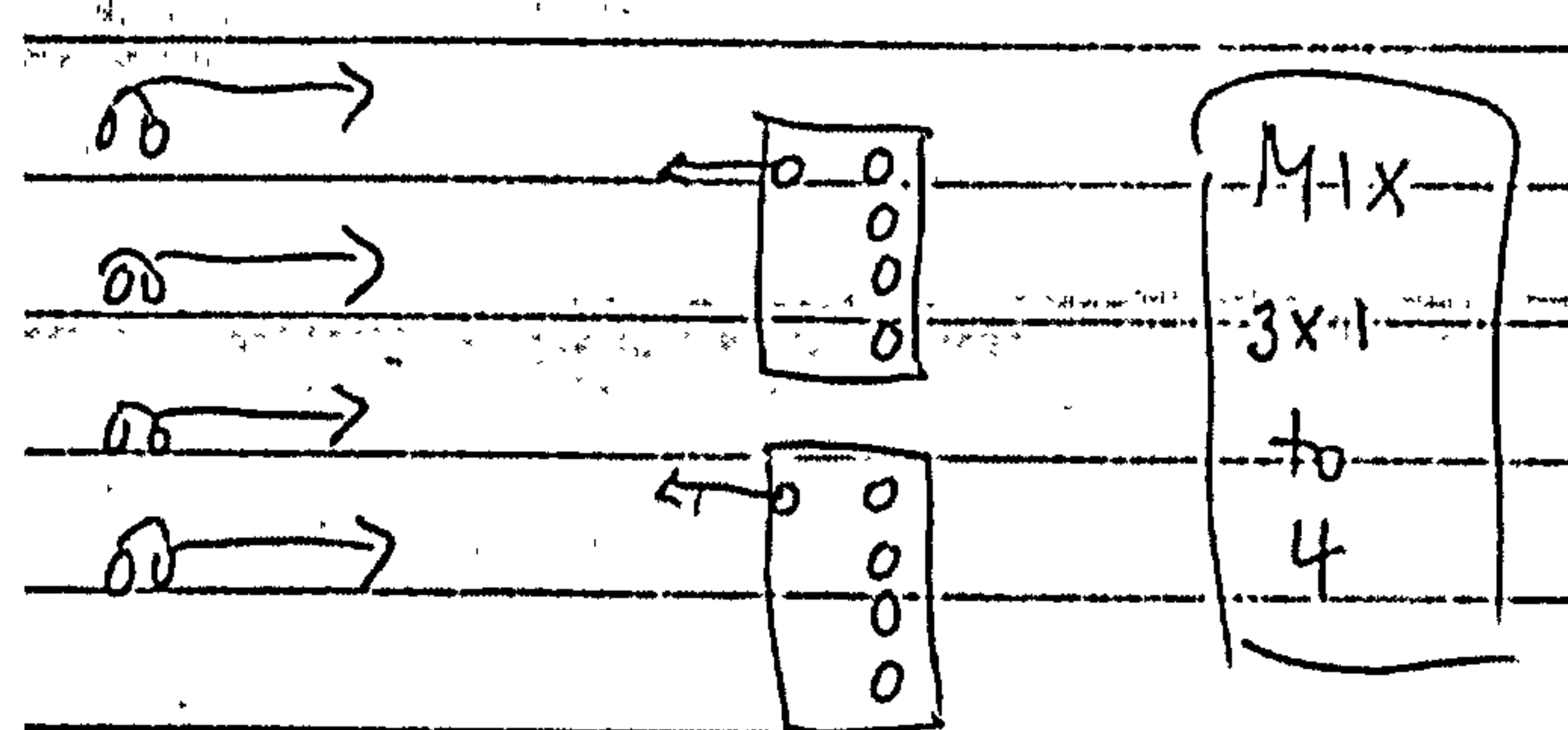

Figure 4-8. Preliminary sketch indicating consideration of use of four cassette tape recorders for playback (original Tudor diagram) (Tudor 1972h).

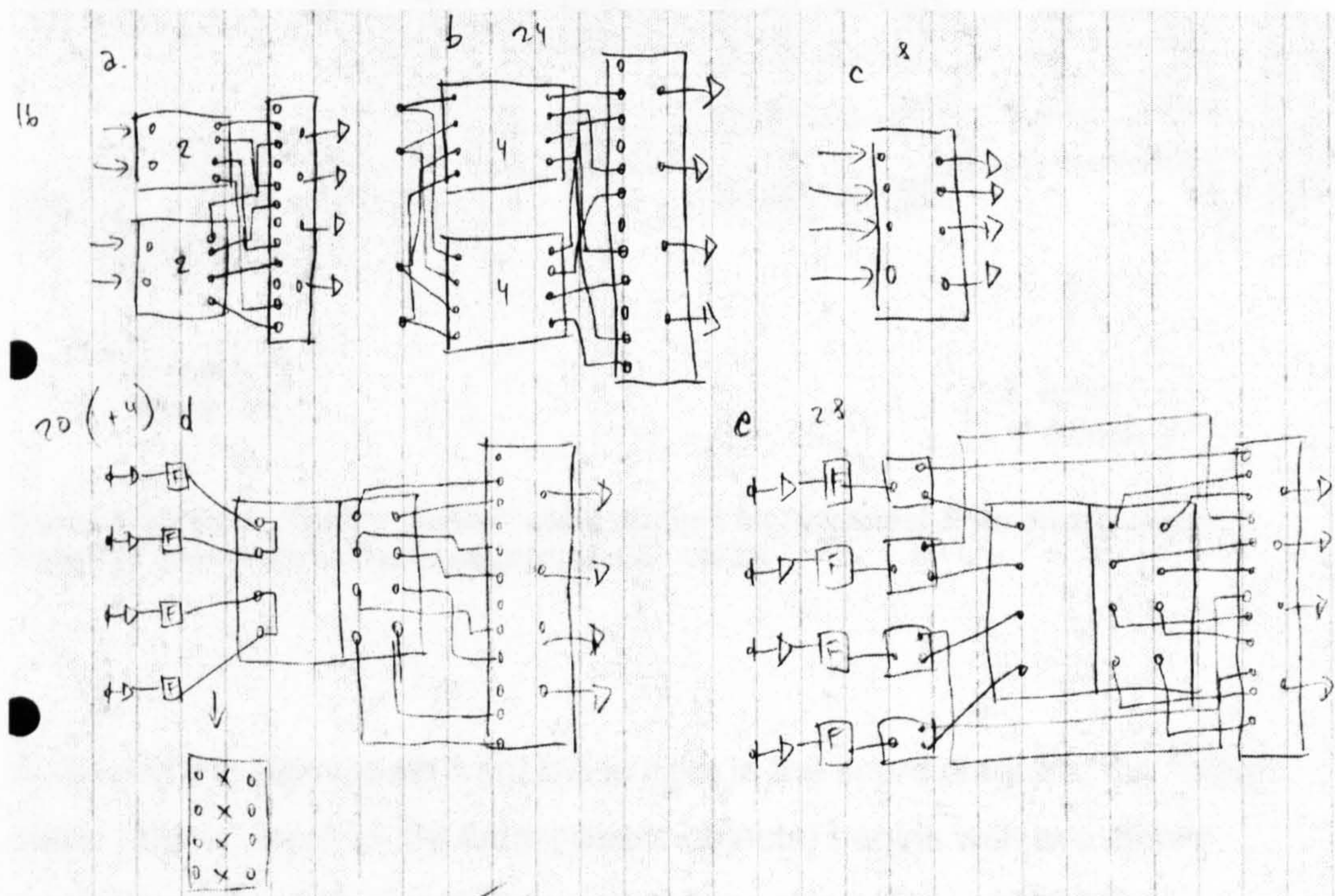

Figure 4-9. Five variations on routing diagrams for mixing and distribution of signals returning from *Rainforest* loudspeaker-objects, with apparent cable counts above each diagram. Boxes labeled "F" are filters. The elongated boxes are active mixers in four sections, each with three inputs and one output. Redrawn by Matt Rogalsky from Tudor's original diagrams (Tudor [undated C]).

Performance of *Rainforest 3*

The "master" score diagram for *Rainforest 3* is clearly identified as such, and represents a great simplification (or streamlining) of the sketches, while maintaining the ideas contained within them (see Figure 4-10).

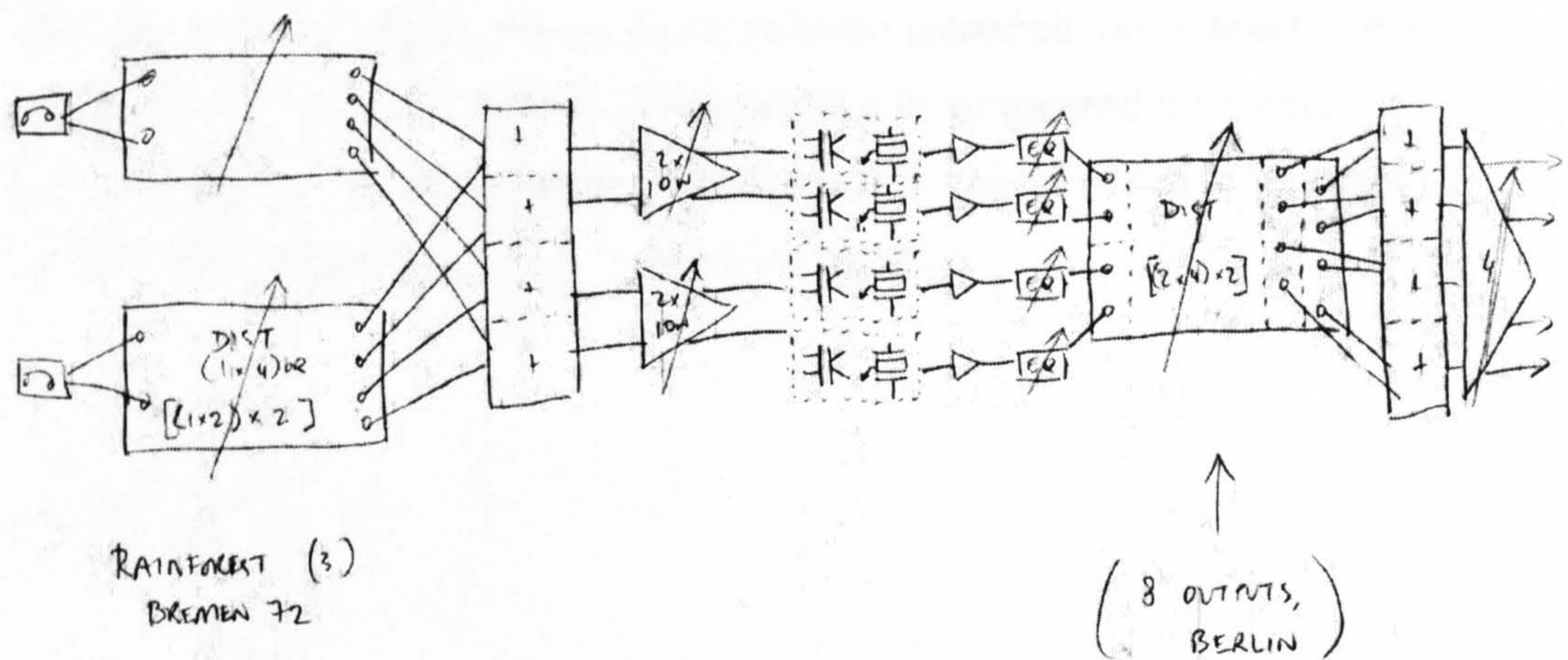

Figure 4-10. David Tudor's "master" score diagram for *Rainforest 3*. Re-drawn by Matt Rogalsky from Tudor's original diagram (Tudor 1972i).

Following the signal path from left to right in the score diagram, the "input" stage (that is, input to the loudspeaker-objects) begins with two stereo cassette decks. The signal from each channel is split by distribution boxes, possibly the "Cybersonics Output Splitter" designed by Gordon Mumma, of which Tudor owned two (Tudor Instrument Collection No. 0002 and 0099). Each of the outputs 1-4 of these splitters is then summed (1 and 1, 2 and 2, etc.), with an unusual homemade active signal mixing box having four discrete sections, each with three inputs and one output (Tudor Instrument Collection No. 0096 and 0097). The summed channels are sent to low-power 10-watt stereo amplifiers, and the amplified signals activate the transducers attached to loudspeaker objects: in Tudor's diagram the objects are identified by dashed-line rectangles. Inside each rectangle on the left is a symbol for the transducer, and on the right is a symbol for the phonograph cartridge attached to the object as a pickup.

The signal from each of the pickups is processed through an active EQ, allowing some modification of the frequency response of the object's resonances. The next stage through which the signals pass is notated as contained within a single device (possibly Tudor Instrument Collection No. 0004): two 2x4 mixers, the outputs of which are then combined (again 1 with 1, 2 with 2, etc.) by another of the unusual mixing boxes as used in

the "object input" stage. This may have been replaced on at least some occasions by four 1x4 splitters: this variation is suggested by a note commenting on "new" features of *Rainforest 3*, one of which is "(1x4)x4" in the "DIST" stage (Figure 4-11) (Tudor 1972e).

RAIN FOREST 3

NEW:

DIST

$[(1 \times 4) \times 4]$

$[+] (4 \times 4)$

EQ AMP (x10 GAIN)
x4
OR x8

Figure 4-11. David Tudor's notes on "new" features of *Rainforest 3*, rewritten by Matt Rogalsky from Tudor's original (Tudor 1972e).

The resulting four channels are then sent to power amplifiers for distribution to conventional loudspeakers placed around the performance space. Although the specification for the piece requested four channels, on at least one occasion it was performed with eight channels, as noted in the diagram for the Berlin performance on July 11 1972 (Figure 4-12).

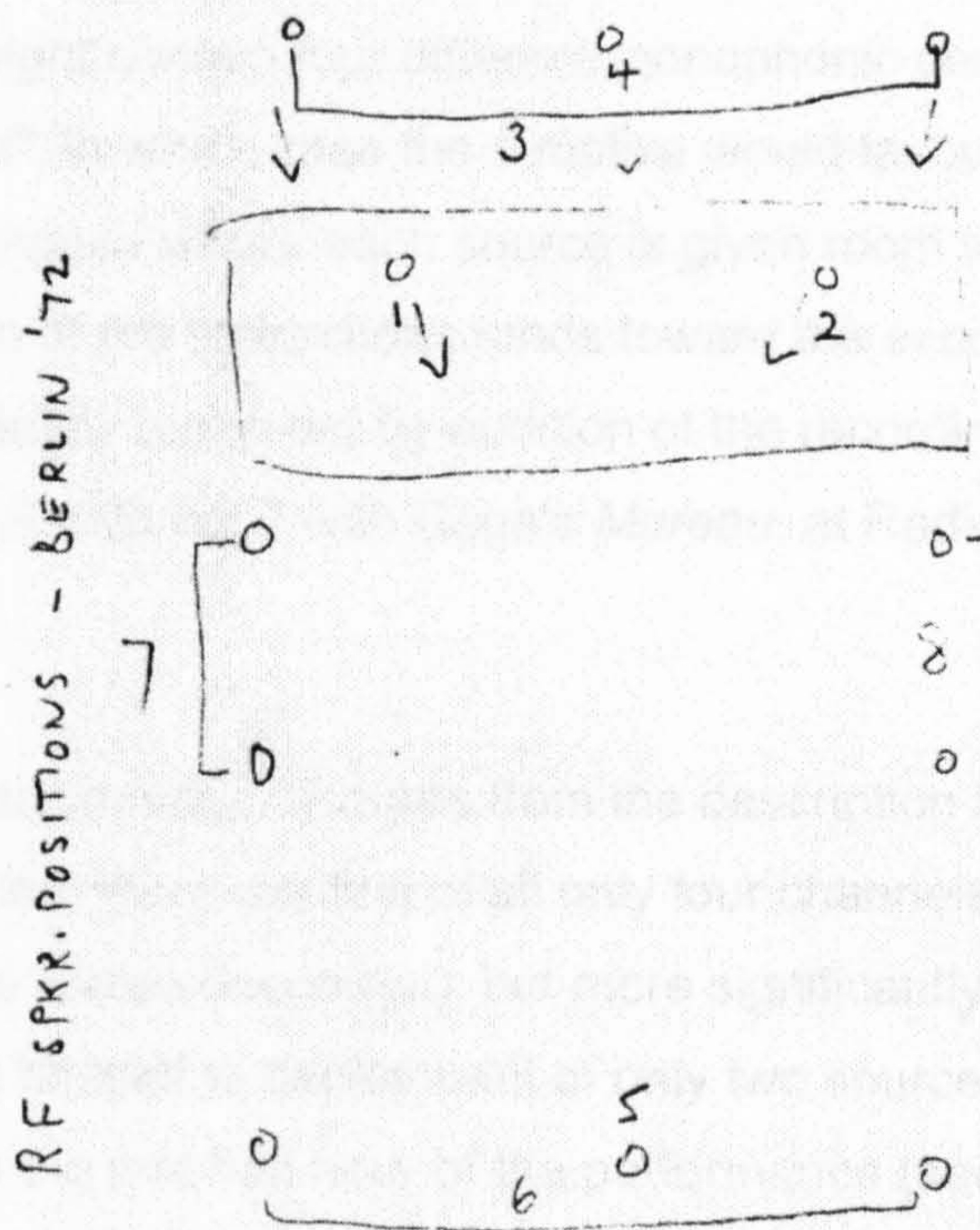

Figure 4-12. David Tudor's original diagram of eight-channel speaker setup for performance of *Rainforest 3*, Berlin, July 11 1972. Cage's *Mureau* used a separate four-channel system (Tudor 1972f).

The "master" score diagram concisely describes the basic setup to be used for performance of *Rainforest 3*, but does not dictate performance style, how to proceed through the wide range of source tapes available, or how to match the recordings with objects. Listening to a recording of Tudor performing alongside Cage provides some illumination, but requires familiarity with the source materials and experience with the actual physical setup of the piece, to decipher (see Figure 4-13).

To reiterate, Tudor's entry in the *Rainforest* "option list" which corresponds to *Rainforest 3* is as follows:

4. Various taped materials used as input. Limit these to two at any given time, distributed among the eight channels.

(Tudor 1968)

It is not entirely explicit from this instruction whether Tudor means "two tapes" (which might contain four different monophonic sources) or "two discrete sources", in which case the directive would favour a less cluttered performance where each source is given room to be fully heard. My interpretation of the instructions tends toward the second reading, but this is not completely borne out by audition of the recording of Tudor's first performance of *Rainforest 3* with Cage's *Mureau*, at Radio Bremen on May 5 1972.

The recorded performance diverges from the description in the "option list" primarily in that there are first of all only four channels (difficult to distinguish in the stereo document), but more significantly in that Tudor does not restrict himself to deployment of only two source recordings at one time. Within the first half hour of the performance (see Figure 4-13), two long stretches occur in which at least three sources are heard simultaneously. Between these two, there is a long solo for what seems to be a single continuous mosquito recording. This pattern of long, monotone sections separating periods of much busier activity occurs often throughout the full duration of the performance.

2:43 - ~5:50	mod EEG slo (+ beetle walking [?] or earth vibes [?])
5:50 - 10:20	cat's eye slow [?]
8:05 - 10:26	mod EEG slo
8:20 - 10:26	beetle walking
10:25 -16:30	mosquitos and/or mosquito slow
16:29 - 27:30	wasp chewing slow -> wasp chewing modified
16:50 - 28:20	mosquitos
16:50 - 22:00	fly paper modified
27:30 - 31:15	unknown intermittent percussive sounds -- perhaps from Cage's microphone? (sounds like metal can being crunched and popped)
27:30 - 31:15	wasp chewing modified

Figure 4-13. Identification of source tapes in first half hour of David Tudor's premiere performance of *Rainforest 3*, with John Cage's *Mureau*, Bremen, May 5 1972. Different shades indicate sounds overlapping significantly in time (timings from version released on CD by New World Records and erroneously described as "*Rainforest II*", New World Records 80540-2).

The combination of more than two sources is frequently heard throughout the full duration of the performance. Each source tape seems to be paired with a single object and not varied throughout its duration, which assists in keeping streams clearly audible. The recording is a valuable document but cannot tell the full story since the live event was performed "in the round" with audience members free to roam within the dual-quad speaker systems, and able to approach the centre of the room where Tudor and Cage were seated. I cannot be sure how the recording was made (i.e. where microphones were positioned), but in photographs the individual speakers are miked, so it may be that an attempt was made fully to capture the experience, albeit in a reduction to stereo. There is substantial ambient noise from audience members on the recording, so

some overhead microphones may also have been used. However the recording was made, the audience's experience would have been substantially different: the concert was not a sit-down, coherent whole from beginning to end but rather a continuity of "events uninterrupted by intermissions etc." (Cage 1971c) having the character of a "performed installation". The audience members, being free to sit close to any given loudspeaker, including Tudor's loudspeaker-objects, and able to come and go at any time, were therefore given agency in deciding how to focus their attention. This freedom was a feature of Tudor's "Pepsi pieces" and of some Cage performances in the few years prior to the 1972 tour; it would remain a preferred mode of operation for Tudor, in *Rainforest 4* and beyond.

One might speculate why the 1972 version of *Rainforest* was not performed after Tudor's tour with Cage that year, given that it was among the most technically simple pieces in his oeuvre and would have been quite easy to maintain in current repertory. The answer may simply be that the impetus for *Rainforest 3* came from Cage's invitation to collaborate, and that when the tour was finished, Cage moved on to new projects and Tudor did as well. Having explored his Pepsi source material satisfactorily in *Rainforest 3*, Tudor retired the piece. The tapes were always close at hand in years following, however, and made appearances in *Rainforest 4* as well as other works as late as 1984 (*Dialects*, in which the Pepsi mosquitos play a large role).

As *Rainforest 3* was driven by Cage's invitation to perform together, the next phase of *Rainforest* was also inspired by external forces, leading to the creation of the large group piece known as *Rainforest 4*.

Chapter 5

***RAINFOREST 4 (1973) AND THE DEVELOPMENT
OF A PERFORMANCE COMMUNITY***

Friend, colleague, teacher, master, collaborator.

Phil Edelstein on David Tudor
(Edelstein, 1996)

David never led the group, unless it was to a particularly good restaurant.

Ralph Jones on David Tudor
(Jones, 2001)

A crossroads in the middle of a *Rainforest*

John Cage and David Tudor's European tour of 1972 was the last for the pair as a performing duo, on their own without the structure of the Merce Cunningham Dance Company. For Tudor, it also seemed to mark the end of the road for *Rainforest*:

[After the 1972 tour ...] I had decided I was through with the piece (laughter). I was asked to give a workshop, so I said: 'OK, I'm gonna give this piece away' (laughter). There the object was to make the sculptures sound in the space themselves. And part of that process is that you're actually creating an environment. [...] the purpose of the contact mike is to take the resonant frequencies which you hear at best very close to the sounding object; to take those into an ordinary loudspeaker which you can consider not as auxiliary but as enhancement. What that does when you establish the proper tonal balance is that you've got a reflection of the sound which you can distance in space. (Tudor, 1984)

Each stage of *Rainforest* was occasioned by an invitation: the pre-*Rainforest* piece *Bandoneon !*, by Tudor's inclusion in the "9 Evenings of Theatre and Engineering" produced by Experiments in Art and Technology in 1966; *Rainforest 1* and *2*, by Merce Cunningham's commission for dance in 1968, and performance opportunities arising from Cunningham tours; *Rainforest 3* by John Cage's invitation to him to participate as a composer in their 1972 tour. The next stage, which resulted in the creation of Tudor's best-known and perhaps most approachable work, *Rainforest 4*, also began as a response to an external stimulus: an invitation to teach on the faculty of a three-week summer new music workshop in New Hampshire in 1973. *Rainforest 4* is a sculptural "performed installation" work for large loudspeaker-objects, which requires group participation in a cooperative, improvisational environment. Group participation was also essential to David Tudor in the making of this version; by most accounts, the metamorphosing of the small-object, "table-top" versions of *Rainforest* into the room-filling *Rainforest 4* was the result of spontaneous, self-directed activity by Tudor's workshop students.

New Music in New Hampshire: a hothouse environment

Petr Kotik, composer, conductor and flautist, had emigrated from Czechoslovakia in 1969 to join the faculty of Center of the Creative and Performing Arts at the State University of New York in Buffalo, NY. In Prague he had already been extremely active in the new music world, forming two ensembles dedicated to performance of new work. When the Cunningham Company toured the world in 1964, Kotik met David Tudor, John Cage and Merce Cunningham in Vienna, where he was studying composition.

Well we knew each other very well, David [Tudor] and I. We performed together in 1964 when the Cunningham Company was on the world tour and they came to Prague. I was 22, I had my ensemble for several years. I met Cunningham and Cage in May, when they came to Vienna. [Unrecognizable] called me and said, Cage is coming, do you want to perform with him? We have no idea what he wants, he never gave us any specifics. [...] And we performed together and, you know, the relationship just clicked, with Cage, and they were all thrilled. That was *Event No. 1*. [...] we did *Atlas Eclipticalis* for three hours, for which we had a nine-minute rehearsal. (Kotik, 2005a)

Following the Vienna performance, Kotik's mother was involved in arranging dates in Prague on the same tour. "I put together an orchestra and we did *Concert for Piano and Orchestra*, David was performing and Cage was conducting. With the Cunningham Company. [...] I remember when the performance finished, all the dancers came to the edge and were looking down, couldn't believe the sound which emanated from the orchestra because they never performed with so many musicians" (Kotik, 2005a). Immediately following the Prague performances, Kotik again performed with the Cunningham Company, as part of the Warsaw Autumn festival. In the 1990s, near the end of Tudor's life, Kotik again mounted performances of *Concert for Piano and Orchestra* with Tudor at

the piano; their professional relationship and friendship were maintained throughout.

Invited by Lejaren Hiller and Lucas Foss at Buffalo's Center of the Creative and Performing Arts, Kotik relocated to the city, where he founded another new music project, the SEM Ensemble, in 1970. Kotik was closely connected with composers in the region, including La Monte Young in Buffalo, John Cage in New York City, and Christian Wolff in New Hampshire; his connection with Wolff was especially important for conceptualization of the 1973 workshop in which *Rainforest 4* developed. (Kotik, 2005a)

In the summer of 1972, Kotik vacationed with his family at Stafford's-in-the-Field, a holiday resort near Chocorua, New Hampshire, which included six cabins, an inn with ten rooms and a large barn, all on 23 acres of property; he also paid a visit to Wolff at his nearby Vermont farm for the one-day "Burdock Festival", a privately organised social and musical event (Kotik, 1995a). The character of the event, having a casual but adventurous and experimental atmosphere, raised the idea in his mind of more formally organising something on a larger scale, but with a similar aesthetic; the resort where he was staying suggested the perfect venue. "I saw that facility there, which was enormous, including that enormous barn, and I thought perhaps we can take over for three weeks. [...] I had never done anything like this before" (Kotik, 2005).

Soon afterwards, Kotik, representing his SEM Ensemble, attended a meeting organized by the New York State Council on the Arts (NYSCA) for its fundees in Buffalo. At the meeting, he encountered Lewis Lloyd, head of the NYSCA Music Section, who had formerly been manager of the Merce Cunningham Dance Company; they recognized each other from the Company's performances in Eastern Europe in 1964. Kotik says: "I mentioned to him the idea [of a new music workshop series at Stafford's-in-the-Field] and he immediately jumped on board, because he is from that area" (Kotik, 2005). Lloyd became a board member of a new

non-profit organisation he named New Music in New Hampshire (NMNH), which was created to develop the idea and produce the event. He was also key in acquiring a grant of \$10,000 from the Rockefeller Foundation to fund it.

Petr Kotik took on the Artistic Directorship of NMNH; Lloyd hired Julia Foulkes-Roberts as administrative director. Others invited to be on the board of directors included Allen Sapp, founder of the Center for the Creative and the Performing Arts in Buffalo; Darragh Park III, a colleague of Sapp's; and Gordon Mumma, full-time musician with the Cunningham Company and member of the Sonic Arts Union. Stafford's-in-the-Field was booked for three weeks between June 21 and July 11 1973, and faculty, drawn from the pool of Kotik's friends and colleagues, were hired to teach a wide range of workshops. These included Gordon Mumma; David Behrman, also a musician with the Cunningham Company; Julius Eastman, who had joined the SEM Ensemble in 1971; pianist/composer Frederic Rzewski; and David Tudor. Kotik himself was also engaged to teach a workshop (see course descriptions in Figure 5-1).

Invitations to teach were extended based on friendships, professional relationships, and personal references which gave Kotik confidence about the quality of the outcome, without knowing precisely what each instructor might be interested in teaching (Kotik 2005a). Of Tudor, Kotik says he received no clues beforehand:

I expected nobody to teach really. I expected them to be there and do some work and take some students along as apprentices. This is what I believe is the essence of learning something. Not some formal lectures. That was the furthest from my mind, to provide such a structured program. So there was really nothing I could discuss with anyone. (Kotik, 2005)

David Tudor received two copies of his contract for the New Music in New Hampshire teaching engagement, both of which remain unsigned in his archive at the Getty Research Institute (Tudor 1973f).

Course descriptions were soon formulated for distribution to potential students in a professional-looking registration package which requested applicants to choose three courses from the six on offer, in order of preference, with the possibility that they might attend all three, scheduling permitting. Three of the six courses offered focused on aspects of new music involving electronics: Behrman and Mumma offered instruction in building devices and learning the basics of electronic circuit design; David Tudor offered "RAINFOREST: Experimental electronic workshop in sound transformation without modulation: building and performance" (New Music in New Hampshire, 1973). Students were recommended to bring a "standard set of electronic tools" for Tudor's course (New Music in New Hampshire 1973a).

By the time of the Chocorua workshop, David Tudor had performed *Rainforest 1* with Merce Cunningham's dance *RainForest* on at least 77 occasions between 1968 and 1972, when the dance was first retired from repertory. During this time period, also with the Cunningham Company, he had presented what he later dubbed *Rainforest 2*, in an unknown number of performances. His summer tour of Europe in 1972 with John Cage incorporated five performances of *Rainforest 3*. It is hardly surprising that Tudor might have felt by 1973 that *Rainforest* had reached a maturity which suggested it needed either to be abandoned, or reinvented; the invitation from Petr Kotik to participate as faculty at the Chocorua workshop provided a situation Tudor could use to do the latter. Without this impetus it seems unlikely that *Rainforest* would have taken the direction it next did; and as Petr Kotik says, if it were not for the setting in which performances were to be held, it might not have taken on the large-scale sculptural presence which it did (Kotik 2005b).

The three weeks of the workshop were scheduled with courses in morning, afternoon and evening, Monday-Saturday, with Sundays left unplanned. David Tudor gave morning classes only, every other teaching day, beginning on June 22. The evenings of July 3-8 were blocked out for

a "festival" of performances by NMNH participants, with the fruits of Tudor's workshop to be shown on the evening of July 6.

New Music in New Hampshire attracted 28 students from across the United States and Canada, and it was afterwards judged by Petr Kotik to have been an unqualified success:

The premises of Stafford's-in-the-Field, being located outside of the community, the number of all participants (36 - including administrative staff) and everybody's dedication to the program, created an excellent atmosphere in which to work. It also made it possible to establish in a very short period of time a close personal relationship between all students, faculty and the administration. [...] Every night a large group of students stayed in the Barn and improvised or rehearsed, sometimes until 1 A.M. Another group of students worked in the laboratories of D. Behrman and D. Tudor, located in the rooms at the rear of the Inn, sometimes until early morning hours. A third center of evening activities was in the Library and the reading room where discussions were going on every night. [...] The program for the festival was assembled out of suggested pieces by the students and faculty. Luckily we were able to perform all suggested pieces although it did mean adding one additional performance [...] The entire Festival provided an excellent opportunity for all participants to confront works of music, coming out of different parts of the country, representing the avant-garde streams of today's musical life. (New Music in New Hampshire 1973c)

NEW MUSIC IN NEW HAMPSHIRE

JUNE 21 - JULY 11, 1973

at STAFFORD'S-IN-THE-FIELD, Chocorua, New Hampshire

SUMMER COURSES, WORKSHOPS & PERFORMANCES

- | | | |
|-----|---|------------------|
| (A) | MUSIC COMPOSITION/WORKSHOP
Structuring sounds and space, using the voice, instruments, and body discipline. | JULIUS EASTMAN |
| (B) | WORKSHOP IN DESIGNING, BUILDING AND PERFORMING ON ELECTRONIC MUSIC SYNTHESIZERS
Participants in the course will build a collection of electronic devices; voltage-controlled amplifiers & oscillators; envelope generators, modulators, equalizers, etc. | DAVID BEHRMAN |
| (C) | OPEN FORM - A NEW APPROACH TO STRUCTURING MUSIC
Time: present, future and past; closed form, open form: conceptions and results. | PETR KOTIK |
| (D) | INTRODUCTION TO SOLID-STATE ELECTRONICS FOR CREATIVE ARTISTS
Basic concepts of electronic circuits and media transaltion. Linear and non-linear amplification, oscillators, filters and equalization. Analog and digital operations. Basic theater and commercial sound practice. | GORDON MUMMA |
| (E) | INSTRUMENTAL MUSIC
Workshop in interpretation of new scores, performance techniques of new music, improvisation and composition in real time. | FREDERIC RZEWSKI |
| (F) | RAINFOREST
Experimental electronic workshop in sound transformation without modulation: building and performance. | DAVID TUDOR |
-

Enrollment will be limited to 50 students. In addition to course attendance, students will participate in a series of public performances between July 3-8. These performances will include student, faculty and collaborative work prepared in the previous 2 week period.

Figure 5-1. New Music in New Hampshire course list (New Music in New Hampshire, 1973).

Rainforest at New Music in New Hampshire: the students

Yeah, when I did it I thought of it, the fact that I was giving away this piece. It was like a class, a small class and I had to show them how to do it, so I felt like I was giving it away. (Tudor 1995)

New Music in New Hampshire attracted 28 students, from a diversity of backgrounds. In this thesis I will focus on the subset of David Tudor's students which went on to perform extensively with him under the group name Composers Inside Electronics: John Driscoll, Phil Edelstein, Linda Fisher, Ralph Jones, Martin Kalve and Bill Viola. Not all of these students participated in the first performance of *Rainforest 4* at Chocorua, and there were other students who participated in the first performance but did not continue their relationship with *Rainforest* in the years following.

David Tudor was well-known for inscrutability where his music was concerned, behaviour exemplified by a well-known story John Cage often told, which was re-told by Mary Caroline Richards at Tudor's memorial service in 1996:

David also had a way of speaking in conundrums. One special example is the response he made to a student [at Black Mountain College] who was asking for some special information about musical performance (I think) — David's response was "If you don't know, why do you ask?" — memorable! (Richards 1997)

The students who came to Tudor at Chocorua did not receive quite such a gnomic reception, but Bill Viola's account of the group's first meeting suggests that Tudor was unused to the situation and, while not unfriendly, was somewhat inhibited in his role of instructor. "Things got underway with little or no introduction, with David talking in halting sentences punctuated by long silent pauses, rarely looking anyone in the eye. This, plus his formidable reputation, made us all feel quite intimidated at first, and there was a nervous, unsettled feeling in the room" (Viola 2004).

The following section of this chapter provides a short introduction to the six of Tudor's Chocorua students who went on to work closely with him for the next decade in *Rainforest 4*. These introductions are partial biographies, focusing on the type of work each student had been doing, as artist, composer, musician and/or performer, in the several years immediately before the Chocorua workshops. What is clear is that none of these individuals was interested in identifying him or herself as fitting within one category; interdisciplinarity was key in their work, and each was closely connected with experimental use of new technologies in the arts. In 1973 all were in their early 20s; Tudor was 47. Their adoption of Tudor as guru, and the formation of Composers Inside Electronics around his mentorship, is uncommon, and perhaps unique in the history of contemporary music.

The work of Driscoll, Edelstein, Fisher, Jones, Kalve and Viola, within the context of Composers Inside Electronics will be considered in more detail in chapter six.

Bill Viola

Viola, born in 1951, is now well-known as a primarily video-based artist, and is certainly the highest-profile artist to have emerged from the Chocorua group. In 1973 he was an emerging artist working heavily with sound performance and installation, and his experiments of the time mirrored the interests of Alvin Lucier, La Monte Young, and Tudor himself. Explorations of resonance, and electronics, occupied his imagination: "I remember the thing I was doing just before I met David, I was starting to take my tapes made on the Moog and play them through rooms, and re-record them, as a way to get a different sound to it but also to put it back in the real world again [...] I was starting to do circuit design, I was starting to make my own oscillators and sound things" (Viola, 2000). In 1972 and 1973, while he was already familiar with video technology through collaboration with the Synapse group at Syracuse

University (which he co-founded), and was creating video-based artworks, Viola also created four sound installations. One was *Hallway Nodes* (1972), for "hallway 22 ft. long containing 2 Altec Lansing Voice of the Theatre loudspeakers at each end monitoring 2 sine wave oscillators heterodyning at 50 Hz [...] This creates varying densities of "resonance" in the space — or nodal points, which (at this frequency) will be 'felt' as much as heard" (Viola 1995, 37). Another, entitled *Broadcast Spirit Release* (1973), employs "inaudible mutterings" heard from speakers placed beyond a blinding light source, with the ambient sounds of the room "electronically amplified and heightened a bit" with "microphones under the floor", while a video camera records the presence of visitors and sends their image "off into space" (Viola 1995, 36).

An amplified floor was specified for *In the Footsteps of Those Who Have Marched Before* (1973): visitors heard a recording of heavy, marching footsteps and were put in the position of being in or out of synchronization with the marching, when walking through the space (Viola 1995, 34). Another 1973 sound work, *The Mysterious Virtue*, is similar to 1972's *Hallway Nodes*: Viola theatrically presents a "pile of stones from a river bed on a straw mat - wooden floor. High intensity light illuminates the pile of stones from above [...] Two loudspeakers broadcast two 55 Hz sine tones respectively - this produces a heterodyning standing wave that spills out over the rocks" (Viola 1995, 35).

Viola says that David Tudor "arrived at the most amazing time for me, because he was more than just a musician. [...] I think of him as a sculptor too, the way he talked about sound, the way he dealt with it as a physical material" (Viola, 2000). In 1973 Viola was, he says, having a crisis of sorts with the

[...] abstraction of electronic sound, something that just troubled me about it, its disconnectedness from the human world [...] I remember really struggling to try to feel those electrons, sort of bouncing around the wires, that would help me understand what an oscillator was doing. [...] the whole *Rainforest* thing was a mind-

opening experience, that sound could travel through these things, that could break this glass if you hit it at the resonant frequency... that really helped me out of this dilemma. (Viola 2000)

It was not only the physical demonstration of transforming sound through "acoustic filters" but also Tudor's collection of recordings from the Pepsi Pavilion project of 1970, which stimulated Viola's imagination.

Tudor had this amazing library of natural sounds he had collected for the 1970 Osaka World's Fair [...] I have to say I was really taken by the poetry. A beetle walking across an amplified surface—to me that was just as important as the formal quality of the sound, probably more important. The fact that it was a beetle, and it was as avant-garde as anything I'd ever heard, was really critical. And I made tons of sound recordings, he also turned me on to field recording, which in my video work again became absolutely essential. (Viola 2000)

The practice of field recording—long periods of motionless "meditation" with a microphone beside a frog pond, for instance—shaped Viola's video practice, which became defined by static camera shots showing a wide field of view. "I learned", says Viola, "to keep my camera still and let the sound do the work" (Viola 2000). A 1986 postcard to Tudor acknowledges, "after all, you did teach me to hear with my eyes" (Viola 1986).

Ralph Jones

Ralph Jones, also born in 1951, was in 1973 an MA student in composition at SUNY Buffalo, studying with Lejaren Hiller and Julius Eastman (CIE 1980a). His master's thesis project involved the design and construction of a microphone able to transpose ultrasonic signals into the audible range (Jones 2001). He was also a member of the Creative Associates, along with Eastman and Petr Kotik, and had toured and performed with them. His first compositions were for tape, and he had become familiar with an early Moog synthesizer in the university's studio;

he sought out Robert Moog, who lived in Buffalo as well, to study analog circuit design with him privately, which he did for

a little over two years, so by the time I went to Chocorua I had a little of that experience under my belt, a lot more to gain, but I had built circuits and I had learned something about circuit design and was working to apply it to musical ends. (Jones 2001)

The period 1970 to 1973, Jones says, was a "marvelous, wonderful time" at SUNY Buffalo.

All the prominent people came through, from Xenakis to Cage. I met virtually all of them, and performed their work—performed stuff of Pauline's [Oliveros]. Allen Sapper really put together a very active scene, and Michael Tilson Thomas was conductor of the Philharmonic at that time. [...] Not only music. Gerry O'Grady, around that period [... ,] founded Media Study Buffalo, and he was head of the Media Study department at the university, so all of these wonderful and very interesting and challenging filmmakers and videomakers were coming through also. So it was a terrifically fertile time, with a lot of foment of ideas and cross-communication among people working in various media". (Jones 2001)

Jones recalls that Petr Kotik made it possible for him to attend New Music in New Hampshire through provision of a scholarship, and he had equal enthusiasm for the acoustic and electroacoustic aspects of the workshops: Jones participated in Tudor's *Rainforest* course, and the circuit-building classes with Gordon Mumma and David Behrman, but also composed a piece for multiple flutes (or optionally, one flute with tape delay system) while in residence. *Saturday Afternoon 5 O'Clock* was influenced by "the acoustic of the barn and by the bird songs I heard there" (Jones 2005a) and was performed in the last week of the workshop by Petr Kotik and students Ruth Abbinanti, Richard Hayman, Richard Palanzi, and Susan Stenger. Although Jones became an integral part of Tudor's post-Chocorua *Rainforest 4* group, he chose not to perform in the piece on its first occasion, citing a lack of "well-enough

developed objects", as well as the appearance of his flute piece on another programme (Jones, 2001).

Phil Edelstein

In 1971, Phil Edelstein (born 1950) co-founded Electronic Body Arts Inc, an Albany-based intermedia organization working with dance, music and technology, and from 1971 to 1977 acted as its Media Director (the organisation was formally incorporated in 1973). The founders "insisted on the name, because such arts as lighting, audio synthesis and video are integral to the EBA repertoire" (Electronic Body Arts, 1979). Edelstein says: "I didn't seem to have any affinity for any of the traditional forms, but *Events* [Cunningham Company *Events*, often with improvised sonic accompaniment] made complete and utter sense to me as a base mode of operation" (Edelstein 2005a).

Edelstein identified as an intermedia artist, as his involvement with EBA suggests, but he leaned heavily toward sound: from 1971 he was creating "collaborations or solo works for audio tape, electronic synthesis or found instruments", and between 1972 and 1976 he identified himself as an "electronicist/composer/performer" in the realisation and performance of works by contemporary composers (Edelstein 1980).

From 1967 to 1973 Edelstein also worked as a freelance computer programmer, creating applications for business and scientific data processing (Edelstein 1980), and in 1973, just prior to Chocorua, he had completed a Bachelor of Science degree in interdisciplinary studies in technology and art at SUNY Albany, working closely with Joel Chadabe in the university's electronic music studio. Following Chocorua, Edelstein took up a position at Wesleyan University as Visiting Faculty in the Computer Arts Laboratory, "teaching techniques for graphics and music" (Edelstein 1980). A biography from 1980 states: "The common thread

connecting all of his work has been his use of electronics with other disciplines" (CIE 1980a).

Edelstein recalls he had heard David Tudor perform his work *Monobird* (a version of one of the Pepsi Pavilion pieces) at SUNY Albany in 1972, and "had this kind of hit, a junkie on his first real mainline—and completely dumbstruck by DT mixology" (Edelstein 2005a). Soon afterward, the information about New Music in New Hampshire was posted on the electronic music studio's bulletin board, and Chadabe aided Edelstein in obtaining a half-scholarship to attend.

Martin Kalve

Kalve, born 1951, was in 1973 a fourth-year fellow student of Ralph Jones at SUNY Buffalo. He had studied composition with Lejaren Hiller, Julius Eastman, William Kothe, Jan Williams, and electronic music with Ramon Fuller. He had been working since 1969 with electronic music, and was a participating member artist of the Buffalo Mixed Media Workshop in 1971. Kalve records that his interest in electronic music "became intensified after meeting and working with David Behrman, Gordon Mumma and David Tudor at New Music in New Hampshire in 1973" (CIE 1980a). Kalve also studied viola with Jesse Levine at SUNY Buffalo, and had played the instrument in youth and community orchestras since the mid-1960s (Kalve 1974).

Julius Eastman suggested to Kalve that he come to the New Music in New Hampshire workshops; Kalve was awarded a grant making it possible for him to attend. At Chocorua, in the workshops of Mumma, Behrman and Tudor, he developed a "bio-feedback system for people, balls and resonating objects" (Kalve 1974) entitled *et puis... et puis... est-ce que je puis?*, which was subsequently presented in Buffalo later the same year, and again in 1976 as part of the Composers Inside Electronics residency at the Festival d'Automne in Paris. The piece

existed as a sound installation rather than a composition; Kalve described it as a "kinetic piece" exploring social interactions and musical play (Kalve 2003). The audience was invited to look down upon a collection of amplified objects, from the balcony of the Stafford's-in-the-Field barn, and "activate" them by dropping ping-pong balls. The resulting sounds of the resonating objects were gated with a logic circuit (created with the assistance of Ralph Jones) activated by the shadows of the audience members cast on photocell sensors as they moved about (Kalve 2003).

Following the Chocorua workshops, Kalve was instrumental in setting up a mail network amongst workshop alumnae and other interested individuals, with the goal of establishing a performance group to realize new music by group members as well as other composers. This group eventually chose the name "Pnumbral Raincoast", and it shared some membership with the group of Chocorua students who continued to perform *Rainforest 4*, but otherwise had little connection with David Tudor. Pnumbral Raincoast will be considered in more detail later in this chapter as another vibrant outcome of the New Music in New Hampshire workshops.

John Driscoll

John Driscoll was the senior, by several years, of the six New Music in New Hampshire participants who afterward continued to work on *Rainforest 4* with David Tudor. Born in 1947, Driscoll began working in the area of sound sculpture and electronic music in 1968, and was also connected with SUNY Buffalo, having obtained an MA in interdisciplinary art in 1971. His early work involved composition of music for tape, and also used handbuilt electronic devices and "elaborate visual scoring techniques" (CIE 1980a). The sound sculptures Driscoll was making at the time of New Music in New Hampshire were visitor-activated, "triggered by people approaching them, and produced sound in response to people interacting with them". Encountering David Tudor's *Rainforest*

at Chocorua, Driscoll says he found the loudspeaker-object concept was "the perfect marriage between sculpture and music" (Driscoll 2000b).

Driscoll came to Chocorua via Gordon Mumma: "I had been working on a bunch of sound sculptures, and I had come across the *Pavilion* book" (Driscoll 2000b). This was the book (E.A.T. 1972) published by Experiments in Art and Technology documenting the 1970 Pepsi Pavilion at Osaka's World's Fair, for which Tudor and Mumma had significant roles in design of its sound system.

I was looking through *Pavilion*, and there was this description of a modulator that Gordon had built and I thought, well that'd be a nice thing to try, so I came up to New York and caught the Cunningham Company and spoke with him afterward and said I was very interested and asked if there was any possibility of getting a schematic. He said yes, and gave me a schematic and I started working on that. And then about halfway through he said, well, you know, really you should throw that out and start using chips instead. [laughs] So I came back up to talk with him about it and just as I was leaving he said, "see you in Chocorua". And I said Chocorua what? And he said oh, there's going to be this festival up there and he explained it and said there'll be a tuition of such and such. I said well I couldn't really afford that so he said I'll get you a scholarship. (Driscoll 2000b)

Driscoll went to the workshops looking forward to the circuit design courses offered by Mumma and Behrman, thinking they would help "push things along" in his *Pavilion* circuit building project. "That's really what I went up there for, and in the midst of that I came across David sitting in the back room of this old house there, and he had two objects suspended and chirping away" (Driscoll 2000b).

Driscoll's experience with *Rainforest* at Chocorua influenced the direction of much of his own work exploring resonance in the years following, and he took a great deal of responsibility in the continued performance of *Rainforest 4*, acting as an assistant to David Tudor, and organiser for the community of performers which realized it; he eventually moved into a

house at the Gate Hill Road Co-operative Community near Stony Point, NY, where Tudor lived. "With David I always felt that a piece was a way station on a whole series of ideas" (Driscoll 2000b).

Linda Fisher

In 1973, Linda Fisher was already an accomplished musician and composer, as a member of one of the seminal synthesizer-based bands, Mother Mallard's Portable Masterpiece Company. Mother Mallard, formed by composer/performer David Borden in Ithaca NY in 1969, grew out of inspiration provided by the musicians of the Cunningham Company: Borden writes that "seeing them perform live electronic music forever changed my way of thinking about performing music. Especially electronic music. Up until then I thought of it as making tapes in a studio; after that I always thought of electronic music as something to be performed live" (Borden [undated]). The Mother Mallard ensemble, initially a duo with Borden and Steve Drews, developed in parallel to the beginnings of "pattern minimalism", and Borden's work was in part a response to the music of Terry Riley, Steve Reich and Philip Glass, as much as the more anarchic performance aesthetic of Tudor, Cage, Behrman and Mumma. The instrumentation was the Moog synthesizer; Robert Moog lived a short distance away and assisted Borden financially with the acquisition of instruments as well as recommending the group whenever he was questioned about synthesizer concerts. In a short time Mother Mallard had begun to build a cult following as the only Moog synthesizer ensemble in North America.

Linda Fisher, then playing rock keyboards in Ithaca, was invited to play with Mother Mallard in 1970 and brought with her the group's only polyphonic keyboard, an electric piano. By 1971 she was a full-time member of the group, still centred in Ithaca but performing regularly in New York City and elsewhere. When in the city, Fisher says that she and Borden often visited Mumma and Behrman and "there was quite a lot of

friendliness between us" (Fisher 2003). In the spring of 1973, the Cunningham Company was invited to perform at Cornell University in Ithaca, and an invitation was extended for Mother Mallard to join the company musicians to accompany a Cunningham *Event*. Fisher recalls,

[...] they had their little group of tables and the four of them were there—it was John Cage, David Tudor, David Behrman and Gordon Mumma—and then Mother Mallard set up next to them their little group of synthesizers and keyboards. And I really don't remember whether we started out with any guidelines about that performance, but at any rate it was kind of a jam, I guess. And afterwards, Gordon Mumma came up and told me how much he had liked what I had done, and I don't remember what that was, but he liked it. And a couple weeks later he gave me a call and said that there was going to be a new music festival or workshop—some kind of gathering—in Chocorua, New Hampshire and that there were going to be six so-called artists in residence—it would be Gordon, David Behrman, David Tudor, Julius Eastman, Petr Kotik and Frederic Rzewski—and that each of them were allowed to have one scholarship student, so to speak, who could come and be fully funded. And so he wanted to offer that position to me. And I was thrilled, of course, and so I said yes, I'll go.

Fisher recalls arriving at Stafford's-in-the-Field and meeting John Driscoll in the parking lot, and "in close succession, Bill Viola, almost immediately, and Martin and Ralph and Phil Edelstein, and so on. I came completely open-minded—I had no idea what I was going to find there. I mean, I knew something about what the Cunningham musicians did, and I knew Julius Eastman—I had heard of all these guys—but you know, I was pretty inexperienced" (Fisher, 2003).

Other Chocorua '73 *Rainforest* workshop participants

In addition to the six individuals who formed the core of the group which went on to perform *Rainforest 4* with David Tudor, there were at least four other participants in Tudor's workshop, three of whom participated in the Chocorua performance: Ritty Burchfield, Ann Sandifur, Susan Palmer and Gregory Kramer.

Kramer, who traveled from California to attend the workshop, brought with him his own modular synthesizer which he employed in Tudor's workshop. He did not participate in the *Rainforest* performance, however, since during the object-testing phase he over-exercised the only transducers available to him, and burned them out.

Burchfield has already been mentioned in earlier chapters as a close colleague of Tudor's on the Pepsi Pavilion project of 1970; she was, along with Peter Poole and Tudor, responsible for accumulating the large collection of field recordings which were intended for use by invited Pepsi artists, and which afterward fueled *Rainforest 3* as well as other Tudor compositions. Burchfield worked with Tudor's management company Performing Artservices, and accompanied Tudor and Cage on their summer European tour of 1972. Through Artservices she had also become involved with experimental theatre director Robert Wilson's epic-scale performances, and found a role as a whirling dancer in Wilson's "Byrd Hoffman School of Byrds", performing in a number of works such as the twelve-hour *The Life and Times of Josef Stalin*.

Burchfield came to Chocorua not as a student, but as an assistant: David Tudor had "invited me to help with the workshop so I assisted him, as I did on several tours at that time. It was a great time and I remember it much more as fun than work. [...] There is a personal side to this in that my father died just before, in June, and I had returned from Paris to be with him in Texas. David was very concerned and kind to offer me this opportunity to continue working with him. It meant a lot to me to be part of the workshop, especially at that time" (Burchfield 2005).

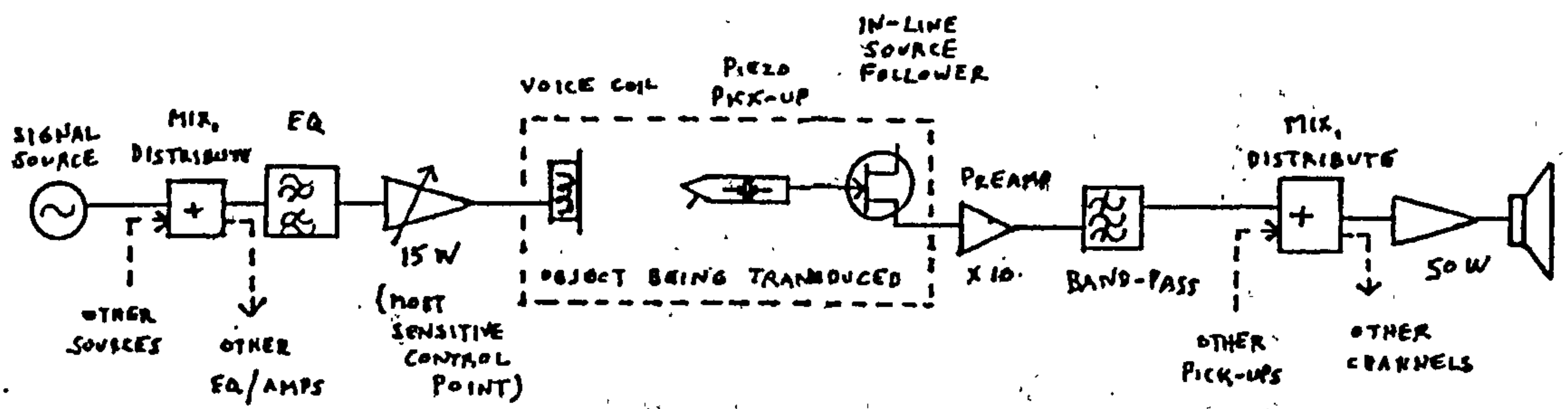

RAINFOREST (4)

GENERALIZED

d. tudor 173

Figure 5-2. *Rainforest 4* generalized score diagram (Tudor, 1973a).

Giving away / receiving *Rainforest 4*

David Tudor came to Chocorua prepared to teach a group of younger musicians how to perform *Rainforest*, which until that point had consisted of versions for small-to-medium sized loudspeaker objects. As has already been mentioned, Tudor's stated goal was to "give the piece away", but in one interview I conducted with him, Tudor also spoke of "protecting" himself in the execution of the "giving away", by providing such a strong example that the students would be drawn to follow it:

[...] when I did it I thought of it, the fact that I was giving away this piece. It was like a class, a small class and I had to show them how to do it, so I felt like I was giving it away. But ah, in order to protect myself I did the following. I had been given a very beautiful object by, I think it was John Driscoll who found, I think it was the rim of a wagon wheel. And so I said, I know just what to do with that and so I made him set it up for me. And uh, then I listened to it a little bit, and I spent an evening making a recording for it. And you know, it was rather gorgeous. So it then became, you know, in the afternoon we planned the opening night. So they wanted me to, they said they all thought I should do the first sound. So I played this tape through the wagon wheel and it worked like a charm....like it set the tone for anything else which came. (Tudor 1995)

Tudor's comment that he needed to "protect" himself while "giving away" his work is revealing; *Rainforest* by this time was Tudor's longest-running project, and while he was apparently ready for a new direction in the piece, he clearly felt he needed to reserve the right to shape its sonic direction, acting in the very traditional role of teacher, to protect his investment in the piece as composer/performer. According to Tudor's anecdote, this moment came on July 7 1973, the day of the first performance of what would become known as *Rainforest 4*. In the two weeks before that, however, Tudor had worked patiently side by side with his students, developing their ears for the piece; while he "didn't say much at all" (Viola 2004), he clearly made a strong impact on the group, none of whom had any previous contact with *Rainforest*. "He was the most amazing teacher", says Bill Viola, "because he showed us the principle of *Rainforest*, he explained what resonance was, and demonstrated it without a lot of words, he wasn't a man of many words. And once you got it, you got it on its terms" (Viola 2000). Viola's "getting" the piece "on its terms" recalls Tudor's own comments on *Rainforest*, repeated on several occasions: "I always thought it was a nice piece because it would teach itself. It teaches itself" (Tudor 1995).

Clearly a large part of the learning process when approaching *Rainforest* must be accomplished by trial and error, and the piece "teaches itself" in the sense that there is a fairly rapid learning curve in coming to grips with object resonances, once the basic idea of the transduced object is communicated. It is possible to break down the process of learning *Rainforest 4* into three distinct streams: understanding the loudspeaker-object; selecting audio sources; and dealing with the spatial presence of the piece.

First, at the more prosaic, technical end of things, it is the concept of the resonating object, and the amplification of the object's own sounds, which must be grappled with. This is the part of the learning process which can be grasped to a large extent by examining Tudor's *Rainforest 4* score diagram in Figure 5-2. This shows, in detail, the signal path for a single

loudspeaker object, from signal source, through equalization and low-power amplification, to the transducer attached to the object. Then, as in all previous versions of *Rainforest*, there is a pickup (in Figure 5-2, shown graphically as a phonograph cartridge) with preamplification stages, further equalization, and then amplification through a power amplifier which enables the object resonances to be heard through a conventional sound system. This diagram does not provide any information, however, about what type of objects to use, or where on the objects to attach transducers or pickups: discovering what works and what does not is the part of this first stream of learning *Rainforest* which is of necessity done by the person who wishes to perform it, and in this sense the piece "teaches itself".

In previous versions of *Rainforest*, Tudor's diagrams were specific about how many objects to use: eight for *Rainforest 1* (and, presumably, *Rainforest 2*), four for *Rainforest 3*. The diagram in Figure 5-2 is "generalized" for any number of objects, indicated by the dashed lines showing potential signals from "other sources" going to "other EQ/amps" (and other transduced objects), then signals returning from "other pickups" which may be directed to "other channels" of conventional amplification. While this diagram is clear-cut in its depiction of technical means, nothing is indicated about what type of "signal sources" ought to be employed, or how a potentially large number of performers ought to interact.

This suggests a second important stream in the *Rainforest* learning process: a stream which goes beyond the piece "teaching itself" and practically demands personal interaction with an instructor, or familiarity with Tudor's concepts for earlier *Rainforest* realisations. This is the process of deciding upon audio source materials, and their deployment in an ongoing performance of *Rainforest 4*. The work is of an "open form", and the success of its performance depends upon consensus among performers as to what it means to participate in an "open form" piece: "a structure is open if it presents no single view of reality but instead

reinforces those variable conditions under which each unique consciousness becomes manifest" (Delio 1984, 2). "Each unique consciousness", in the case of *Rainforest 4*, presents itself as a sonic contribution to the overall work, and if each is to "become manifest", the soundmakers must work within a communal or cooperative structure of give and take, much as any ensemble of improvising musicians. Having experienced some unfortunate student attempts at *Rainforest 4*, Gordon Mumma has noted that it is easy for the "electronic ecology" (as Tudor sometimes referred to the piece) to become upset if the piece becomes "warfare", with one performer attempting to outdo another (Mumma 2001c).

Tudor's only comments about selection of source materials for *Rainforest 4* are, rather, an injunction *against* a certain category of sounds:

"*Rainforest IV*, 1973, being coherent in its electronic principle, can accept any number of performers, and any kind of signal inputs (excluding only composed musics)" (Tudor 1980). Bill Viola confirmed that this was part of what Tudor communicated to his Chocorua students, for their realization of a group *Rainforest* (Viola 2000). When I queried David Tudor about this "rule", he replied,

I'll tell you what it doesn't mean. It does not mean that you should not compose for it. But it means that you should do something that you do intentionally for the instrument and not just think that the instrument is going to respond, whatever you give it. Well, for instance, it's a delightful exercise to get, like, a transducer that is resonated by a wooden object and one which is resonated by a metal or it could be glass, you know something which rings and then to set yourself up so you can put any sound material through to any object. So, it would be very tempting to make an orchestra of instruments that you could play, you give a tango party and play tango through all of these instruments and one after the other and it would be glorious, I can guarantee you. But it is not going to be my piece. (Tudor 1995)

Bill Viola adds that, in the Chocorua workshop, Tudor also enjoined against use of steady-state oscillators and "pure tones" (Viola 2000),

which suggests that Tudor was striving towards a realisation of the piece which would not revisit closely the soundworld of the 1968 *Rainforest 1*.

An important third part of the *Rainforest 4* learning process also exists: the consideration of the spatial aspects of the piece, in which the visual presence of the objects, and their placement, must balance with the aural. This includes the selection of objects, or the construction of "compound objects" from two or more items fixed together, the distribution of objects in the space, and the placement of a conventional loudspeaker system to enhance the purely acoustic sound of the resonating objects, via their individual pickups. The visual aspects of *Rainforest 4* often seem to take second place to sonic concerns, and rarely has there been an occasion on which time and resources were available fully to prepare the visual: not only deciding how to distribute the objects spatially, but lighting them to bring out the full visual impact of the piece.

Tudor's teaching at Chocorua

For his course, David Tudor was provided with a large attic room at the rear of the inn at Stafford's-in-the-Field, where he set up materials for demonstrating the basic concepts of *Rainforest* to the New Music in New Hampshire students. "It was very hot, it was summer, there was no insulation", recalls Linda Fisher. "There were maybe five or six picnic tables there and that's where we set up and had our soldering irons and our bags and tables and gear" (Fisher 2003).

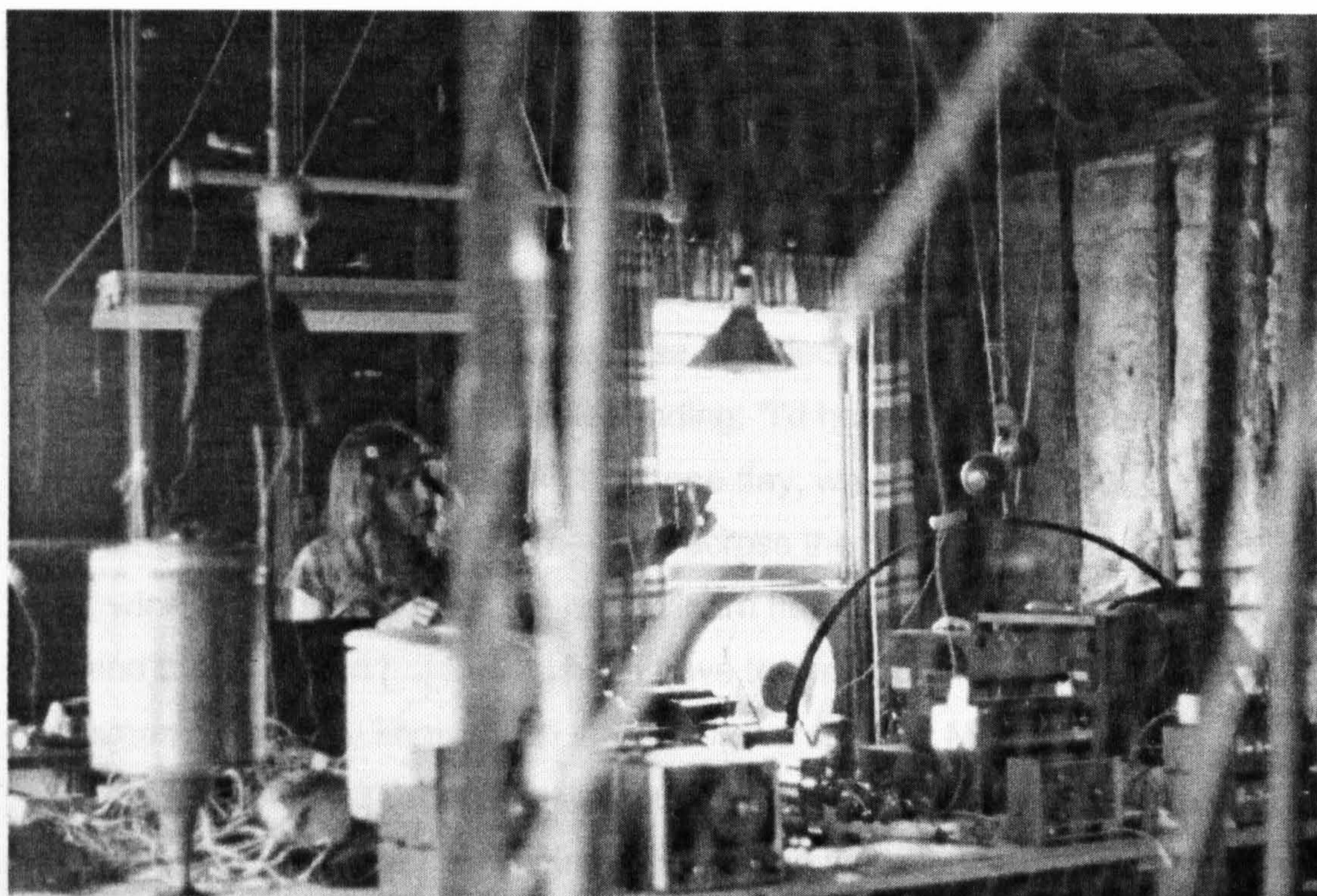

Figure 5-3. A view of the *Rainforest* workshop room in the inn at Stafford's-in-the-Fields, showing David Tudor's assistant Ritty Burchfield, and *Rainforest 4* in development (Photograph by Petr Kotik).

According to John Driscoll, Tudor's class was not the primary draw for the Chocorua students, who were more intensely interested in Mumma's and Behrman's workshops. "David didn't go out and solicit people [laughs]. In other words, with Gordon and David [Behrman] a whole lot of people wanted to jump in because that was right at the cusp of 'gee you can build your own electronics and make your own stuff.' And so that was a real popular workshop, about three-quarters of the people were taking that. The thing with David was that it was more that he was there in residence" (Driscoll 2000a). Driscoll himself had specifically come to work with Mumma and Behrman, and by his own description, came across Tudor unexpectedly, working away quietly in his room in the inn.

Petr Kotik records that "David Behrman and David Tudor's workshops involved about the same students (altogether 12). It took two days to unpack the equipment and prepare all the instruments. The two available

rooms in the rear of the building became laboratories. These workshops met every afternoon and continued until late night. Gordon Mumma's course met 11 times in the early afternoon on the front porch. This course prepared students theoretically for D. Behrman's workshop and gave an introduction into technical problems of electronic music" (New Music in New Hampshire 1973c). Mumma's course included, according to Linda Fisher's recollection, a class in cable winding: "I'd have to say it's been indispensable [...] It was maybe an hour one day, where he threw out these long cables across the room—right across the barn—and then said 'okay, wind them up now,' and we had to learn how to do it fast and do it right and then tie them [...] Even when I have to wind up an extension cord around here, you know, I can still remember Gordon Mumma perfectly" (Fisher 2003). Bill Viola was quoted in a local newspaper article about New Music in New Hampshire as saying he was working on an oscillator, "the first one he's made that will work, now that he's got the guidance [...] 'When this is all over, they tell me, we're all going to be using our creations at once—so we'll probably have 5000 things breaking and smoking' " (Carrol County Independent 1973).

New Music in New Hampshire began on June 21, with each faculty member giving an introduction to their course, to the entire assembled student group. By the evening, the students had selected which they wished to attend, with some choosing as many as four different courses and workshops (New Music in New Hampshire 1973c). On June 22, Tudor began "giving away" *Rainforest*. Among a collection of his notes and diagrams which refer to the Chocorua workshop, there is a single page which appears to outline a teaching plan (Tudor, 1973):

make 1 set-up
teach use
record forest
 perform thru & record

perform mix
 + live inputs via set-up
 (alternate)
outdoors

We can interpret these notes as: make one loudspeaker object setup (object with transducer, contact microphone and necessary amplification); teach the students its function; play some sound materials through the object and record the output of the contact microphone. "Perform mix + live inputs" presumably refers to participation of the entire group, with recorded sounds as well as "live-electronic" signal sources such as the circuits being built in David Behrman's course, while "outdoors" suggests field recording ventures to gather sounds for experimentation with objects..

Bill Viola has provided accounts of David Tudor's process of introducing the students, none of whom had encountered the piece before, to *Rainforest*:

He demonstrated the basic principle behind *Rainforest* by running a sine tone from an audio oscillator into a metal can, using a device called a transducer, which we soon realized acted like the magnetic driver part of a loudspeaker without the surrounding collar. As the oscillator swept the pure tone up through the audible sound spectrum, the object would vibrate and physically rattle, giving off a loud, complex array of sound frequencies, or otherwise fall still and quietly reproduce only the originally pure sound source. David performed this task silently, with the utmost concentration on the object and the sound. (Viola 2004)

He gave us the oscillator demonstration. He told us there were two things we couldn't use [for source sounds] [...] You couldn't do just a pure tone like the demonstration, that was clearly his demonstration model, he was demonstrating the principle of resonance. And then

the main thing was that you cannot use pre-composed music (Viola 2000).

In John Driscoll's account of the introduction to *Rainforest*, he also mentions the absence of spoken instruction: "Well, David didn't communicate much about it, and that's the magic of this whole project. If you got everybody together and asked what David told us about the project it might be about five sentences. [laughter] He wasn't heavy on instruction" (Driscoll 2000b). But Tudor's demonstration of the loudspeaker-object principle made the idea of the piece clear, and the students began to explore the acoustics of "anything we could find around the small converted farm/inn where we were staying—old bedsprings, barrels, cookie sheets, wood planks. Someone blew out two transducers by trying to resonate the bathroom plumbing under the toilet" (Viola 2004). The destruction of *Rainforest* transducers by those new to working with them is all too easy, since they can handle only a fraction of the amplifier power which a conventional speaker is capable of: in an interview Tudor recalled,

There was a guy who was thrilled with the whole [*Rainforest*] process. And what he did sounded very good but when he was testing, [...] whenever he found a result that was very striking he wouldn't leave alone, he would push it some more to see if the object could take it. And he stopped when he had destroyed four transducers. So he realized he was taxing the situation. [...] I didn't stop him but I told him I didn't have more transducers to spare so he would be limited during his actual performance so he got the point [laughs]. (Tudor 1994)

Gregory Kramer was the Chocorua student whose enthusiasm led to the demise of the four transducers, leaving him without resources for the performance of *Rainforest*. He recalls:

My focus came to rest on applying the transducers to large, stationary objects such as the inn's propane tank and plumbing systems. It was promising, even beautiful. However, the power it took to drive these large objects was more than the transducers could handle on a sustained basis. After I burned out several transducers I had to give up my participation as there were no

replacements. So my learning curve (or our learning curve, really, since no one else seemed to know the limits of the transducers) simply did not jibe with participation in the long-term development of *Rainforest*. (Kramer 2005a)

The attitude of patiently allowing students to "fail" in their experiments seems to have been a hallmark of Tudor's teaching style, in which he monitored but did not attempt to overpower or control the situation. "He was just such an open person, really", says Viola. "Put anything in front of him and it was like, innocent until proven guilty. And then we would realize he had opinions, and likes and dislikes, but the initial encounter was openness, and he was truly gleeful about a lot of things we came up with" (Viola 2000).

Linda Fisher recalls that, after Tudor's initial demonstration in the first *Rainforest* workshop class, "I didn't have the foggiest idea what was going on [...] I mean, it just went right over my head" (Fisher 2003). Fisher understood that everybody was supposed to begin experimenting with their own objects, so going outside, she found a cinder block, and brought it into the workshop.

It was really heavy and I hauled it upstairs. The reason I tell this story is because this is characteristic of David. He didn't even say anything. I mean he didn't even bat an eye, like "you dunce", you know — "that won't do anything", or anything like that. He just quietly, patiently began hooking it up. You know, attaching transducers, a contact microphone, and then, you know, nothing happened, of course. I mean, with a transducer that size and something so dense, there was no response. But it was at this moment following this procedure with him, so quietly and attentively as he was, and without judging, that when it didn't work I just instantly understood what the point was and what was supposed to happen and what it was all about. You know, there were no words exchanged really. (Fisher 2003)

Ralph Jones recalled an equally resonant moment with Tudor, as he experimented with a *Rainforest* loudspeaker:

I remember when I broke the ice—when the ice broke, pardon me, it was not I who broke it—with David. [...] It was a particularly hot day, it had to be 100 degrees in the shade easily. And I had been working on a little Chinese bell, maybe six or eight inches tall [...] and I had some live shortwave sound going through this bell and was picking it up with a cartridge and had it amplified, and I was just lolling on this couch sweating like a pig and sort of staring at a dartboard, almost in a trance. And David came in, and I got up to turn it down because I thought he wanted to do something, and he said "No, no, don't turn it off, don't turn it off". And that was when we first really started communicating. (Jones 2001)

These anecdotes suggest much about Tudor's temperament as a teacher. Linda Fisher says his style was to convey knowledge by "clues and hints"; that if pressed he would provide an explanation for something, but otherwise preferred to teach by example (Fisher 2003). Tudor's solo performance which began the Chocorua rendition of the new group version of *Rainforest*, described by himself as a form of "protection" for the piece, "setting the tone" for what was to follow (Tudor 1995), is a clear example of this teaching style.

Scaling up *Rainforest*

The equipment which Tudor had prepared to demonstrate the principles of *Rainforest* to his Chocorua students was based on his Cunningham Company setup: small-scale, "table-top" loudspeaker objects of sizes convenient for packing into touring cases. Over the course of two weeks, the scale of *Rainforest* changed radically; by July 7 1973, when the results of Tudor's workshop were presented in the barn at Stafford's-in-the-Field, the work's new identity as a sculptural, audience-interactive piece, functioning as a free-flowing improvisation space for its musicians, was firmly defined. The conception of the work, and its presentation, did not change dramatically in subsequent performances throughout the 1970s and early 1980s.

The process by which the piece was reinvented during the workshop was, by all accounts, thoroughly unplanned, and was intertwined with the activity of students in David Behrman's circuit-building course, and Gordon Mumma's introduction to electronics class on the porch of the Inn. One of Behrman's most recent compositional projects was a collaboration with Katherine Morton entitled *Homemade Synthesizer Music with Sliding Pitches*; he and Morton had presented the piece earlier in 1973 at The Kitchen in New York City. Composer Tom Johnson described that performance as "a collage of sliding sounds, mostly in the upper register [...] later, the sliding effects become less prominent, and stable pitches take over, fading in and out in various ways" (Johnson 2002, 38). The homemade circuits which were the instrument for this piece were the basis for some of the circuits constructed in Behrman's Chocorua class, which was symbiotic with Tudor's in that students who constructed devices with Behrman could immediately employ them in *Rainforest*. Linda Fisher recalls building "some little oscillators [...] we built circuits and used them to test the objects" (Fisher 2003); Ralph Jones remembers the focus being on construction of preamplifier circuits for *Rainforest*'s phono cartridge pickups (Jones 2001). John Driscoll says: "what a lot of us were doing was building circuits, oscillators and such to use for *Rainforest*, in Gordon and David's workshop. So there was some crossover between the two, building circuits that then we'd use for source generators for *Rainforest*" (Driscoll 2000a).

Behrman's intentions for his workshop were for composers to develop technical skills, an idea which informed Tudor's core group of students as it developed into the ensemble later known as Composers Inside Electronics, in the years following New Music in New Hampshire. Behrman said of his workshop, "Many composers have created good electronic music without ever learning how to design their own circuitry, or even how to repair their equipment [...] But those who know something about electronics certainly have more flexibility" (Johnson 1973).

The connections between Behrman's and Tudor's courses were acknowledged in the title given to the group performance of *Rainforest* on July 7: *Sliding Pitches in the Rainforest in the Field* is a portmanteau title which not only references Behrman and Morton's *Homemade Synthesizer Music with Sliding Pitches*, but also playfully locates the performance geographically by referencing Stafford's-in-the-Field. This long title was not used for any future presentations of the work; after Chocorua it was simply identified as *Rainforest*, with the designation "*Rainforest 4*" not used until a recording of the piece was released on LP in 1981 (Tudor 1981).

Bill Viola recalls that "He brought all this small stuff, for a tabletop piece. He demonstrated to us these things on a table. He had some of them on pipe fittings and stands, and I guess he didn't really anticipate what we were going to do" (Viola 2000). Viola refers here to the sudden appearance in the piece of larger *Rainforest* loudspeakers, which began to occur once Tudor had invited his students to seek out their own found objects. Linda Fisher says the change "happened organically" and had to do with

[...] all of us looking for objects and there being these large objects lying around the farm. And I think there's always the challenge of, can we excite these things? Can we excite something bigger and get it going? [...] (Fisher 2003)

Viola describes the process of "growing" *Rainforest* in two accounts:

Pretty soon we were experimenting with these transducers ourselves, attaching them to anything we could find around [...] old bedsprings, barrels, cookie sheets, wood planks [...] David seemed truly delighted to see what was previously a table-top setup designed for road performances with the Merce Cunningham Dance Company expand into a large-scale singing junkyard. (Viola 2004)

He said we should find objects to transduce and work with, and people started bringing back bedsprings and oil drums and stuff, and suddenly it scaled up, right before his eyes. And then, what do you do with that stuff? Well maybe you have to hang it, so we

started hanging it from the rafters, and then we did this performance in the big barn at the end of the workshop, and the large-scale installation was born. I don't know if he had really anticipated that or not. (Viola 2000)

The larger the objects, the more the question of their physical presence becomes important to deal with; John Driscoll points out that "the schematic for it [*Rainforest*] so to speak, doesn't speak at all of the environmental issue" of how to distribute loudspeaker-objects in an installation. Driscoll speaks of the impressive "scope of the sculptural aspect" of the piece, and explains the development of a visual aesthetic for *Rainforest* in light of his own background as a visual artist: "I think what happened because of my sculpture background, and where people dove in, it probably took a turn to as much a visual aspect as it did a sonic one" (Driscoll 2000a).

Driscoll, having a van able to transport larger items, became central to the project of "scavenging" *Rainforest* objects from the countryside surrounding Stafford's-in-the-Field (Driscoll 2000a). Weekends were spent seeking out useful items, a number of which were not only employed in the performance of *Sliding Pitches in the Rainforest in the Field*, but were afterward retained by Tudor and his students and used over and over again in subsequent performances; even the most recent major realisations of *Rainforest 4* since Tudor's death in 1996 (Lincoln Center, New York City, 1998 and California Institute of the Arts, Valencia California, 2000) have featured some of these "classic" objects, which have taken on something of the status of old friends in relation to the original group of Chocorua performers. Driscoll describes the process of seeking out novel objects in the vicinity of the workshop:

I had just met him and because I had a van we went out and would go scavenging for objects. And that's where we ran across some of the classic ones. We both got these cast-iron wagon wheel rims, and that's where David found the copper still, and a few other objects. We went to flea markets on the weekends. So we started gathering these objects. At first they were small, à la the early

Rainforest objects where it was just tabletop size, and once we found these wagon wheel rims a bunch of us started going "oh well, what if...?" and Bill Viola got a bedspring, and Phil got this big wine barrel, and [...] *Rainforest* went in a direction very different from what David had imagined. [...] I don't think he really envisioned it at that physical scale. (Driscoll 2000a)

Object scavenging could be hazardous; Linda Fisher recalls driving her car with Bill Viola, on a nighttime search for useful items:

We went out in the country to see what we could find and went to a construction site (this was after dark) and saw this long piece of PVC pipe and said "oh, that would be good, let's get that and take it back". And then as we were picking it up the local deputy sheriff drove up and we were in the headlights with our PVC pipe. And he said, "What are you doing?" So we explained, "we're getting this, were going to create an instrument out of it". And I guess we explained it and it sounded crazy enough that he said, "I think you're both crazy and I'm going to let you go, but I don't want to ever see you over here again". So we scurried off, without the pipe, of course. (Fisher 2003)

If Tudor was pleased with the direction *Rainforest* was taking, "He never necessarily encouraged it as much as he just responded" (Driscoll 2000a). Petr Kotik recalls Tudor's enthusiasm for seeking out new items, however, at an enormous nearby flea market, with "big tables of junk, and

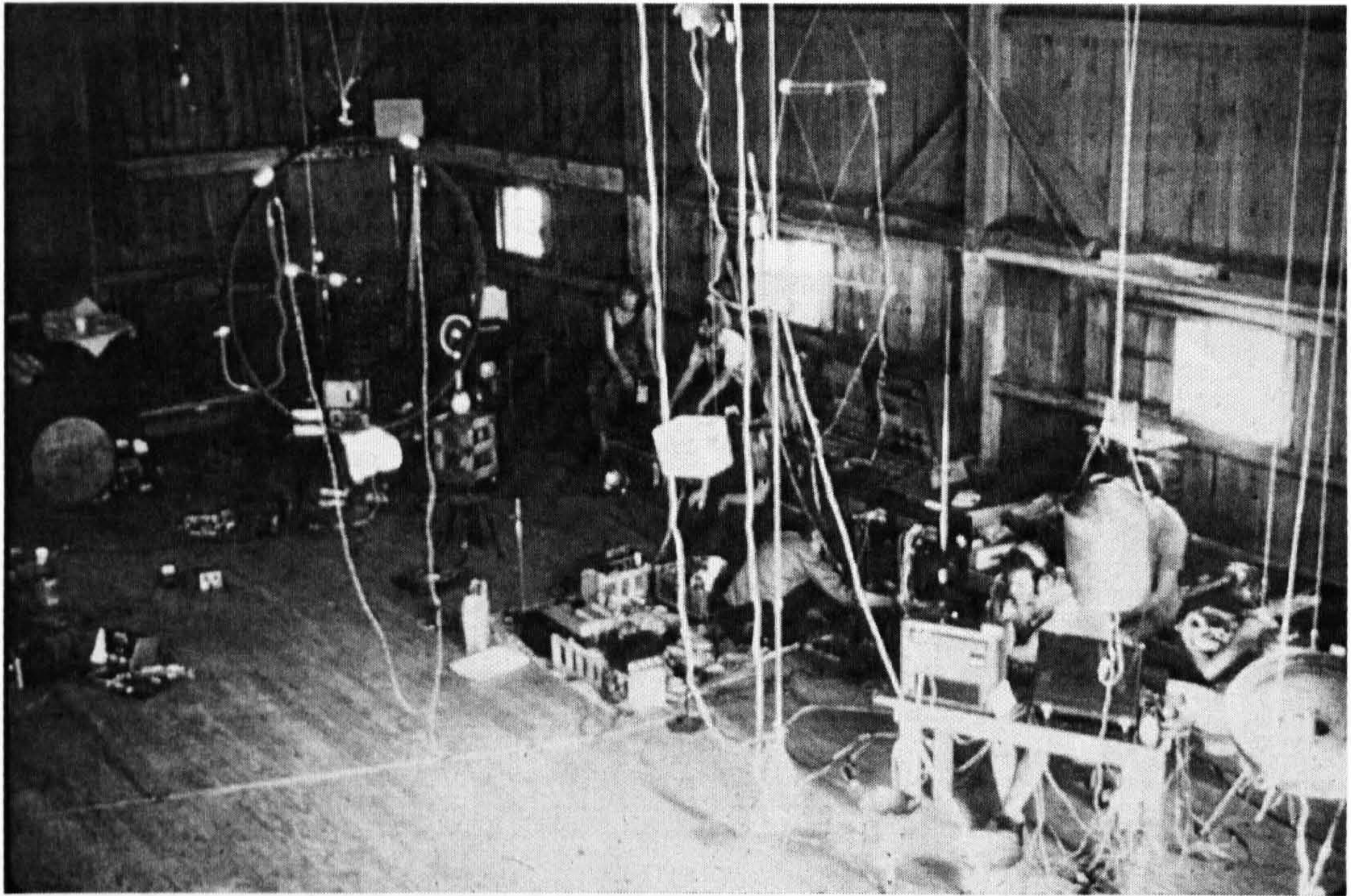
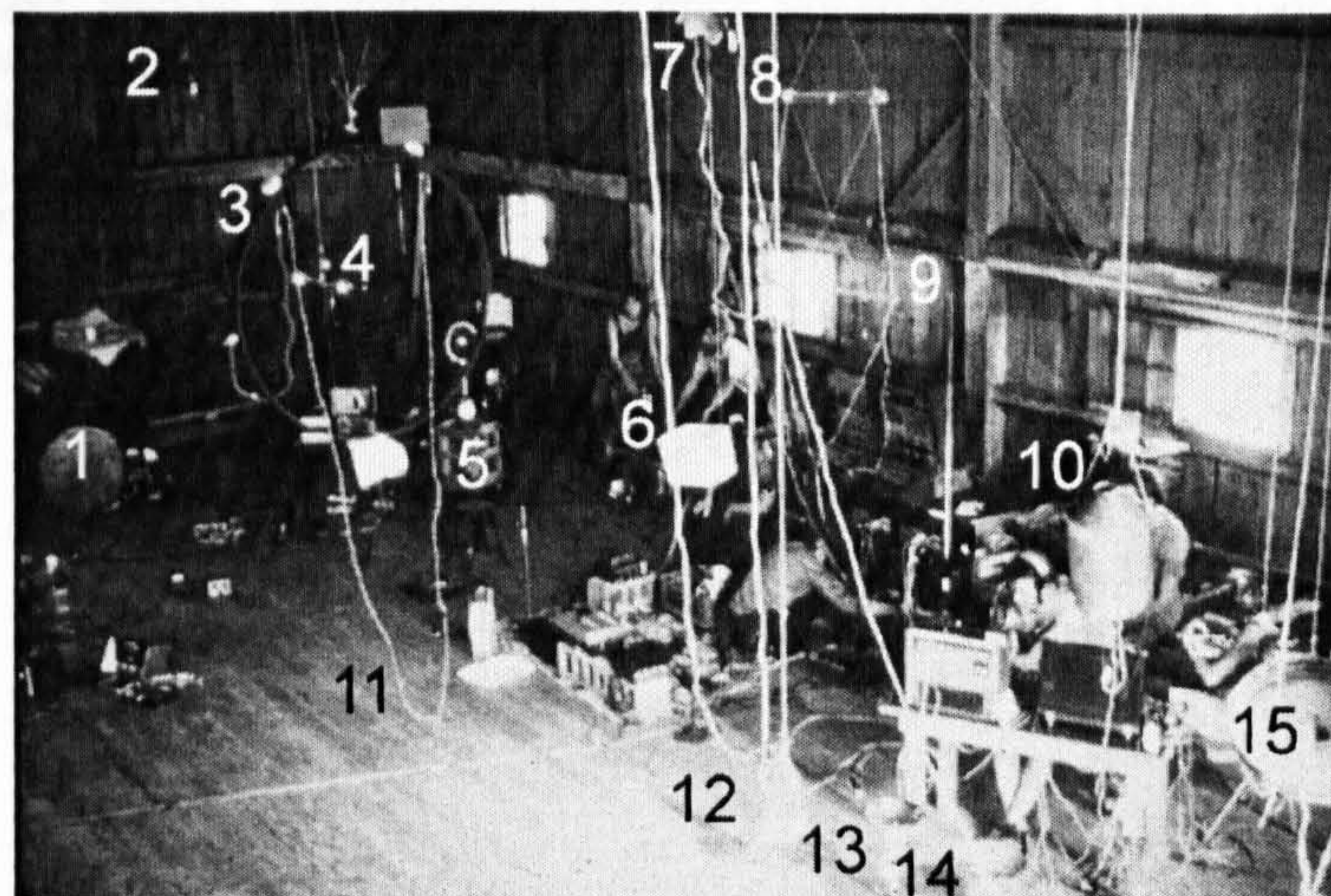

Figure 5-4. View from balcony of preparations for *Sliding Pitches in the Rainforest in the Field*, in the barn at Stafford's-in-the-Field on July 7, 1973. People, left to right: Unidentified woman, Phil Edelstein, John Driscoll, David Tudor, Susan Palmer, Ralph Jones, Linda Fisher. Loudspeaker-objects (see key below): 1. wooden cider barrel 2. plastic lawn sprinkler 3. large wagon wheel rim 4. copper toilet tank floats 5. tennis racket and water bottle 6. styrofoam cooler 7. Chinese bell 8. plastic rod 9. wood dowel 10. copper still 11. 20 foot long metal spring 12. wood knot 13. stainless steel dish 14. metal lamp shade 15. automobile hub. Photograph by John Driscoll, 1973.



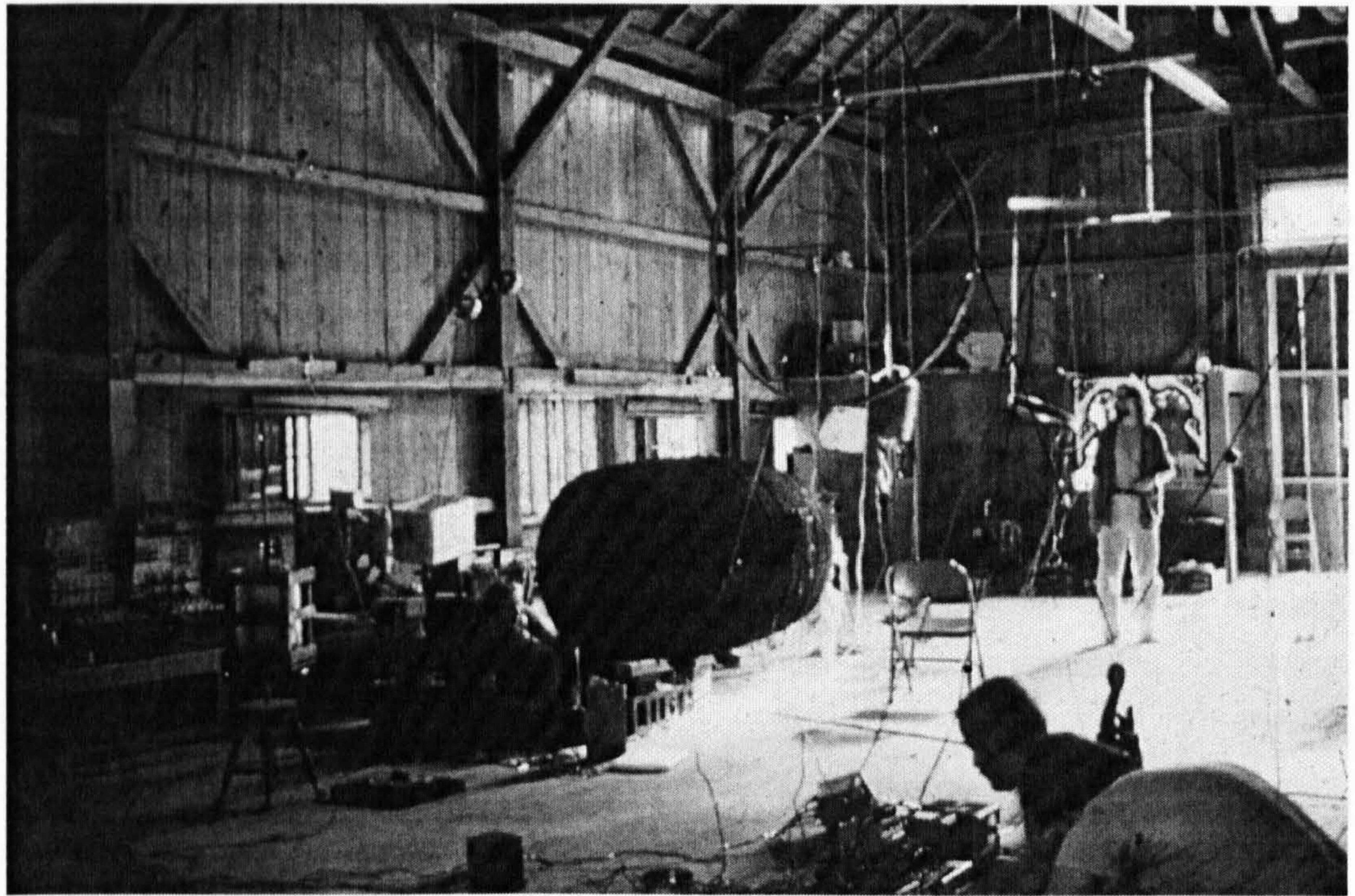

Figure 5-5. View of preparations for *Sliding Pitches in the Rainforest in the Field*, in the barn at Stafford's-in-the-Field on July 7, 1973. People, foreground left to right: Martin Kalve, Bill Viola. People, background left to right: Susan Palmer, David Tudor (obscured by barrel), unidentified man with sunglasses. Visible loudspeaker-objects, left to right: tennis racket and water bottle, styrofoam cooler, toilet tank floats, cider barrel, large wagon wheel rim, copper still, automobile hub, 20-foot metal spring. Photograph by John Driscoll, 1973.

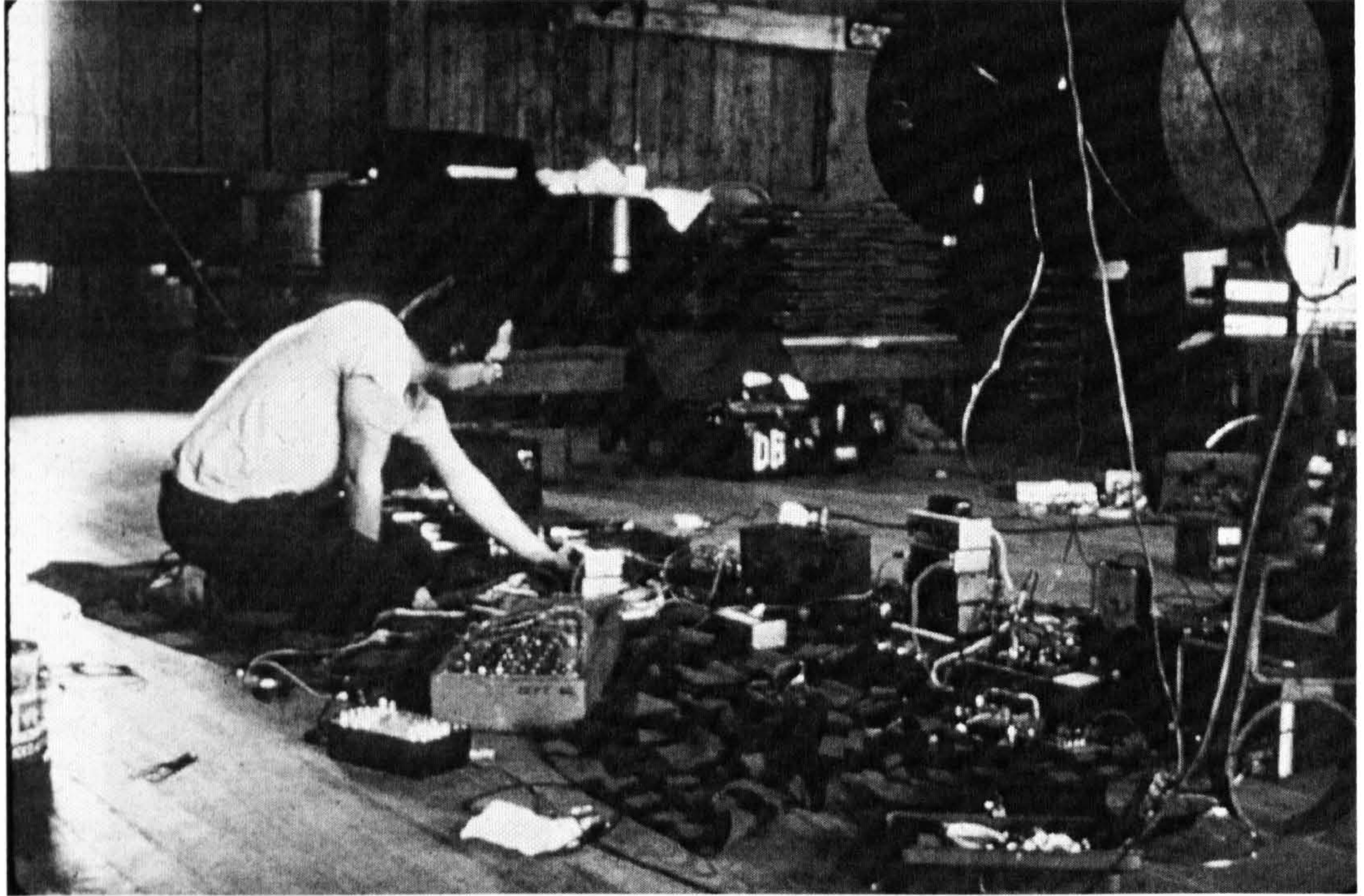

Figure 5-6. View of preparations for *Sliding Pitches in the Rainforest in the Field*, in the barn at Stafford's-in-the-Field on July 7, 1973. Bill Viola pictured, with cider barrel. Photograph by John Driscoll, 1973.

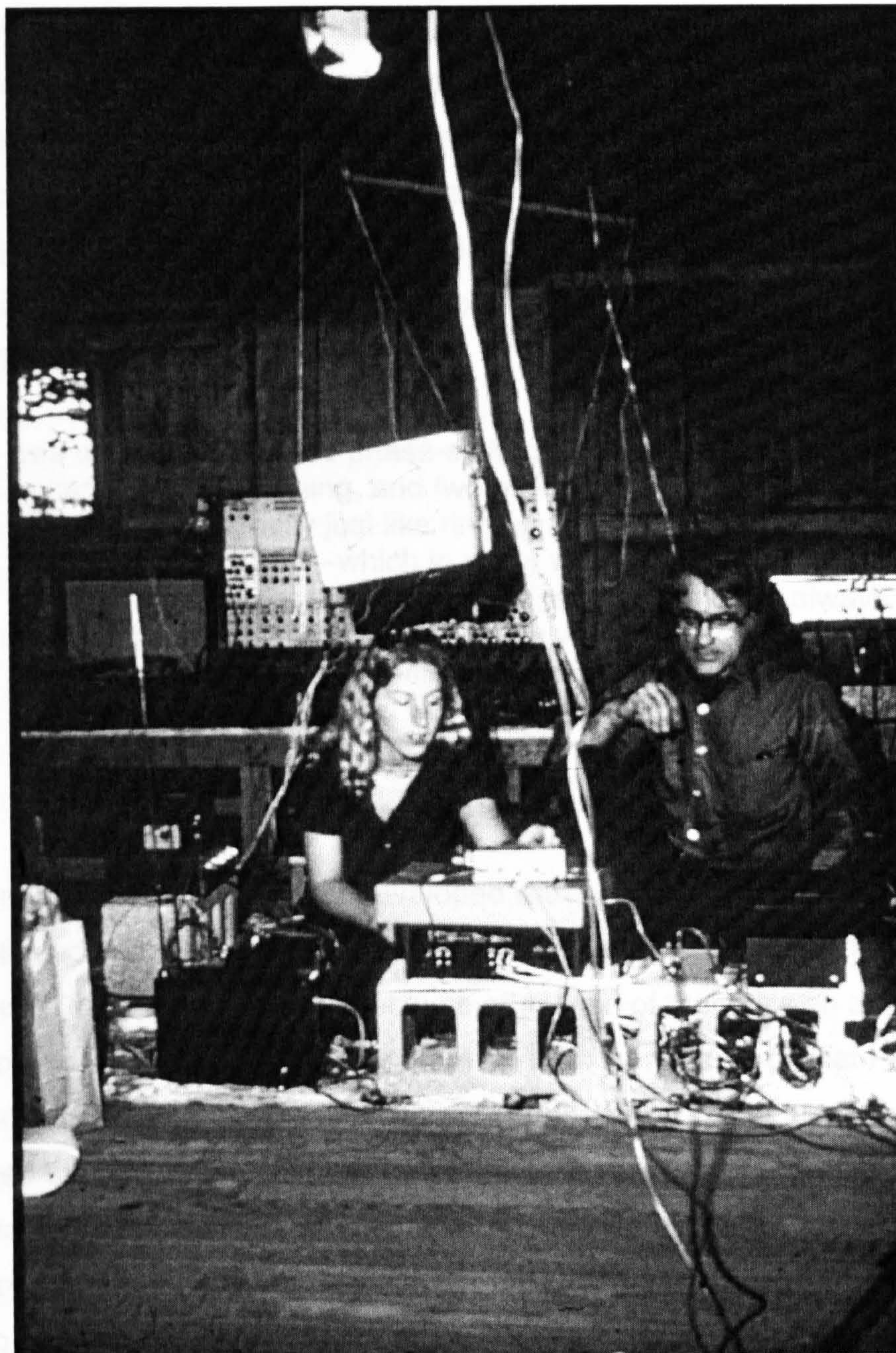

Figure 5-7. View of preparations for *Sliding Pitches in the Rainforest in the Field*, in the barn at Stafford's-in-the-Field on July 7, 1973. David Tudor and Susan Palmer pictured, with wood dowel and styrofoam cooler suspended above. Photograph by John Driscoll, 1973.

among the junk you could find some jewels. I remember specifically that big wheel we bought, and a lot of other objects which still exist in that collection today, we bought right there" (Kotik 2005a). The "big wheel", a circular band of cast iron about six feet in diameter which once had enclosed a wooden wagon wheel, was of particular interest to Tudor, as he specially prepared it with two transducers, and as has already been described, used it to begin his group's performance. Linda Fisher recalls that Tudor

was working with these phase-shifted signals, and so he put two transducers on the thing, and two pickups [...] That object was so beautiful, it was really just like ringing a bell—you know, just the haze of ringing a bell—which in many ways to me is a sort of signature *Rainforest* texture of sound, something that I always think of when I think of it. And of course, he was sending these oscillations, these phase-shifted oscillations, into it. So you got that chirping, bird-like quality as well, and then this cloud of bell-like sound. That was pretty interesting. (Fisher 2003)

The relationship which Tudor developed with specific objects is mentioned in a 1989 interview: "They become my friends. They have personalities, that only I see, because of my use of them. It's an act of discovery. I try to find out what's there and not to make it do what I want but to, you know, release what's there" (Tudor 1989). Tudor may have related to his collection of objects for previous versions of *Rainforest* in a similar way, but the physical size of *Rainforest 4*'s loudspeaker-sculptures, many of them on a human scale, is perhaps more likely to bring about the feeling of "personal" connection which he describes.

The tales behind the acquisition of specific objects may also lend themselves to storytelling which imbues them with special meaning; objects can also be links to geographical locations, forming a history in outline of the places to which *Rainforest 4* has traveled. Despite the fact that *Rainforest 4* could be constructed anew each time it is presented, using objects found in the vicinity of the installation (and many new

objects do appear), part of the reason for keeping old, familiar objects in storage and bringing them out time and time again is surely because they are the history of the work, and provide a thread of continuity from realisation to realisation; they are not required, but when they do appear, their presence is a link to the history of *Rainforest 4*.

"Compound" and site-specific *Rainforest* objects

Although David Tudor had previously experimented with transduced-object loudspeakers which combined two or more items joined together, both in the 1966 piece *Bandoneon !* and in the first version of *Rainforest* in 1968, these were rarities in the history of the piece. For the most part, Tudor seems to have favoured prosaic "found objects", employed essentially unaltered. This seems to be part of the poetry of the piece: the ordinary is made extraordinary. At Chocorua, however, the sculpture background and design interests of John Driscoll led to the introduction of what became known as the "compound object" into the installation version of *Rainforest*. "Compound object" is the term given by Driscoll to loudspeaker-sculptures created by combining two or more objects, often of quite different materials, forms, and sonic properties, into a single resonating unit usually activated by one transducer placed so that its vibrations will be transmitted throughout. "Because of the varying backgrounds of each composer", Driscoll wrote, "some sculptural speakers may be found objects, while others may be more elaborately fabricated sculptures. The simplicity or elaborateness of the sculptural speakers was never specified" (Driscoll and Rogalsky 2004). This openness on Tudor's part, intended or not, was an invitation to his students to exercise their ingenuity, and it resulted in the compound object becoming an important mainstay of *Rainforest 4*. Driscoll seems to have been the sole constructor of compound objects at Chocorua, but in

subsequent performances of *Rainforest 4*, numerous other examples appeared, created by Ralph Jones, Phil Edelstein, Linda Fisher and others. Jones says:

David had a kind of, not just aesthetic, but living philosophy, that when you allow the maximum freedom within an appropriate framework, that the results are lively. And I think that's a really important thing about David, you know, and the way that he dealt with his pieces and his components, and the way that he dealt with others that he worked with. Really I think it was, I'd have to say, a step further beyond what Merce [Cunningham] did and what John [Cage] did, that there was within a framework an incredible freedom. And if you think about it, that's what really makes *Rainforest* what it is, and makes *Rainforest* so alive. You know, John Driscoll introduced the notion of constructed objects—that was not part of the original plan. The toilet float object or things like that. He's made a sculpture, the toilet float object is a made object. (Jones 2001)

The "toilet float object" Jones refers to appears in the first photograph of Figure 5-8: an assemblage of four copper toilet tank floats, connected by threaded metal rods to a central piece of metal, to which is attached a transducer. The vibrations of the transducer are conducted to the floats, which then resonate independently.

In subsequent installations of *Rainforest 4*, Driscoll created numerous variations on this object, with increasing complexity and exuberance in design; the more recent versions of his toilet float sculpture are impressively large, featuring numerous floats extended on the ends of threaded rods up to four or five feet in length. Each float is separated from the others in space, and can be listened to independently, but all are resonated by a single transducer. This is an object which reappears, like some of the other "old friend" objects, but its modular construction means it can be whimsically reinvented for each occasion.

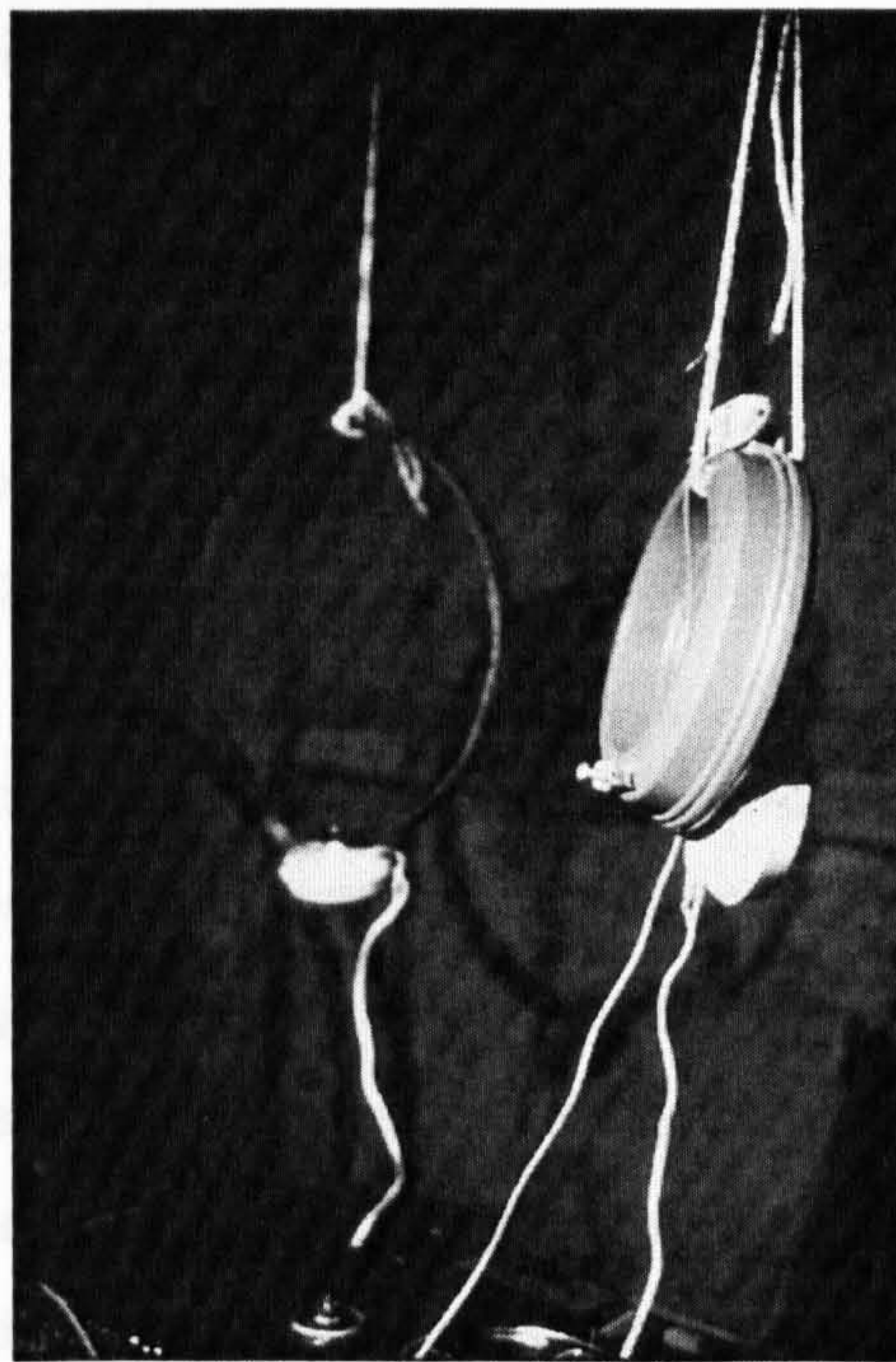
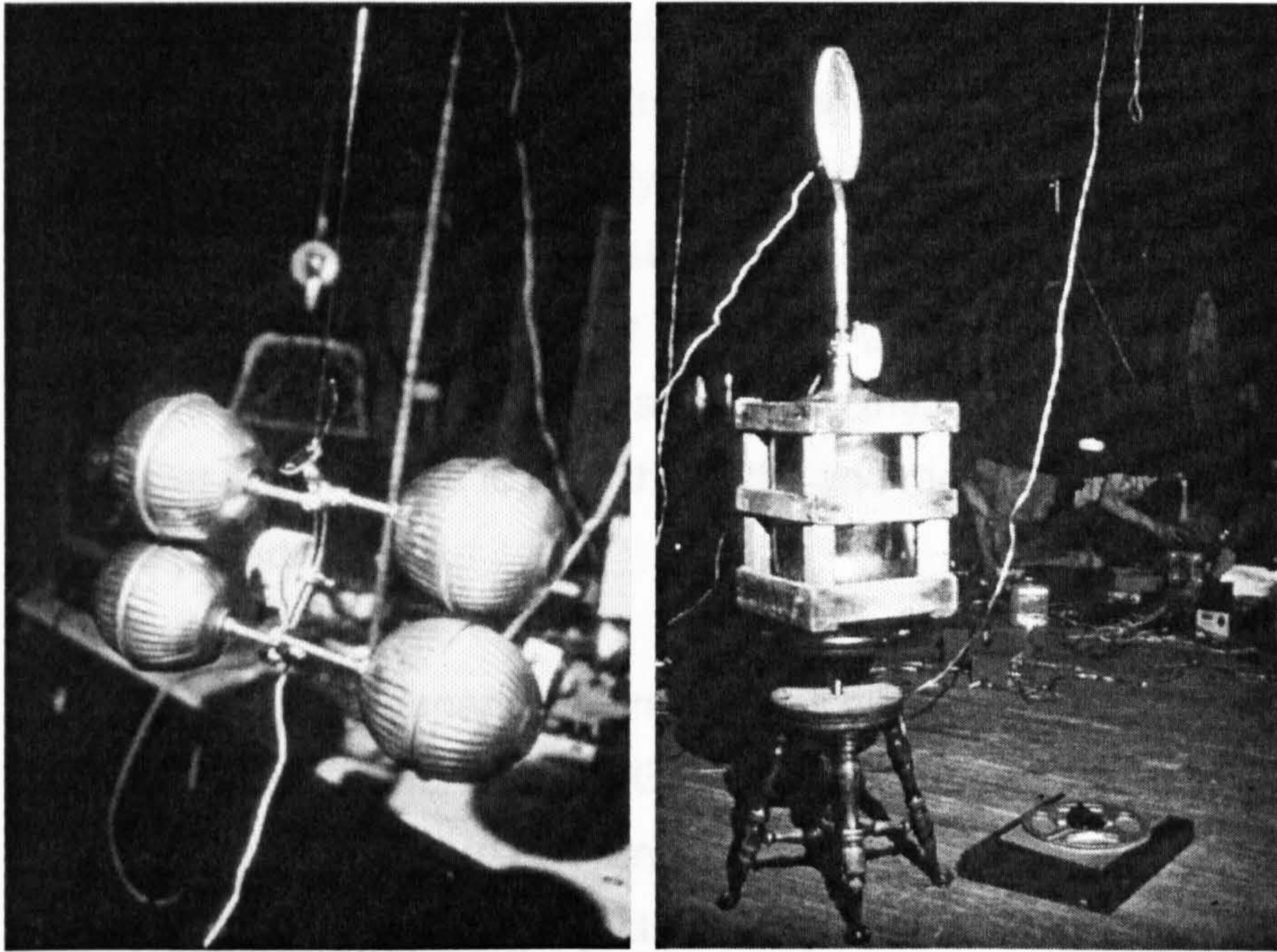

Figure 5-8. View of loudspeaker-objects prepared for *Sliding Pitches in the Rainforest in the Field*, in the barn at Stafford's-in-the-Field on July 7, 1973. Top: "compound objects" designed by John Driscoll, one employing four copper toilet tank floats with a central transducer, the other combining a large glass water bottle with a tennis racket (other objects may be seen in the background: on the left, a metal dustpan, and on the right, the cider barrel). Bottom: the "small wagon wheel rim" and a circular plastic lawn sprinkler. A headphone earpiece was employed as a pickup on the sprinkler object, and is clearly visible taped to the top of the sprinkler. Photograph by John Driscoll, 1973.

The second compound object which Driscoll designed for Chocorua is also pictured in Figure 5-8. Looking somewhat Duchampian (the combination of items would surely put this in his category of "assisted readymade") with a four-legged stool as its base, this sculpture incorporates a heavy glass water bottle sitting inside a wooden crate, with a tennis racket standing upright, attached to the neck of the bottle. The transducer is connected to both the bottle and racket at the point where they are joined.

Another interesting departure from the typically prosaic *Rainforest* loudspeaker was undertaken by Gregory Kramer, who chose to investigate the resonances of "large, stationary objects" (Kramer, 2005) that were "truly 'of the site', objects already part of the environment that could be brought to life in sound" (Kramer, 2005a). Kramer made some progress resonating the inn's plumbing, and its propane tank, and the fact that his objects were site-specific was conceptually satisfying to him. Although he found these objects "promising, even beautiful" (Kramer 2005a), the aforementioned burn-out of his transducers prevented him from continuing to explore their potential.

The use of site-specific features as loudspeaker-objects has not been revisited in subsequent *Rainforest* installations; part of the reason may be difficulty in attaching transducers to permanent features of a venue. Quite often, holes must be drilled in an object to permit a tight connection between it and a transducer, and this is not necessarily an appropriate tactic for objects which belong to the site, and not to the performers. Kramer had to deal with the issue of modifying objects which were part of the inn: "Aside from burnt transducers, other problems came up, such as 'How do I attach this to a tank that could explode if handled poorly?' or 'How do I attach this to the plumbing and get a good attachment without doing something that will cause leakage in an old inn's piping?' You get the idea" (Kramer 2005b).

Planning the performance of

Sliding Pitches in the Rainforest in the Field

Although David Tudor conducted his workshop with a relaxed, *laissez-faire* attitude, the substantial collection of detailed notes which he made toward a successful production of *Sliding Pitches in the Rainforest in the Field* show that he was very careful in planning its technical execution. The situation demanded meticulous organisation, as this project was more demanding of technical resources than any version of *Rainforest* previously attempted: nineteen objects were to be employed, each requiring at least one channel of amplification for its transducer(s); each object required at least one pickup; each pickup then required one channel of preamplification, before all the preamplified signals were mixed using five separate mixers, and then sent to conventional loudspeakers via eight channels of power amplification. The details of the setup for the performance on July 7 1973 are contained in a concise list which Tudor prepared, shown in Figure 5-9 (Tudor 1973d).

This list is a wonderful key to understanding the configuration of the piece, as it itemizes each individual object developed during the *Rainforest* workshop, with all the other resources needed to integrate each object into the whole. It is supplemented with a number of pages of more fragmentary notes and diagrams, and a sketch of fourteen of the loudspeaker-objects, seen in Figure 5-10, showing the outline of each object, the connection point for its pickup(s), and the type of pickup(s) used. Fifteen of these nineteen objects are visible in the photograph in Figure 5-4.

The list can be thought of as an expanded commentary on the generalized *Rainforest 4* score diagram in Figure 5-2; the same stages of signal flow through the piece are defined here, but with much more detail. The list does not name sound sources for objects but it otherwise does provide interesting information about the full signal chain, especially the objects themselves, with their transducers and pickup types. The list may

not reflect the exact setup used in the performance on July 7 1973, but it does appear to be a final draft based on Tudor's other detailed notes, drawings and an earlier, similar list.

The list columns in Figure 5-9 are:

1. Object name
2. Transducer (number and type). "SR" is the "Sound Reproducer" made by Ashworth or Lafayette, "SS" is the Frontier Industries "Sound Star" and "RS" is "Rolen Star"—see Figure 5-11 for photographs of each type.
3. Amplification channel(s) for transducer(s). This column is headed by a right-pointing triangle, the standard schematic diagram symbol for an amplifier. The list indicates use of one eight-channel amplifier (Tudor's original *Rainforest 1* briefcase amplifier, dating from 1968), one four-channel amplifier, and five stereo amplifiers.
4. Pickup (number and type). "Cart" is a phonograph cartridge, "air mic" indicates a conventional dynamic microphone, "cont mic" indicates a contact microphone, and "earphone 2KΩ" is a headphone earpiece used in reverse as an air microphone (visible in photo of "sprinkler" object in Figure 5-8).
5. Preamplification channel(s) for pickup(s). Column also headed with the triangle symbol. "P1" through "P5" are stereo preamplifiers, while triangle symbols in column indicate other unknown preamplifiers.
6. Mixer channels. Column headed with "+" symbol indicates signals being added together. Five small mixers employed, each apparently with two "A" and two "B" inputs.
7. Power amplification channels for the preamplified pickup signals. Also notated with the triangle. Eight channels of power amplification shown.

The nineteen loudspeaker-objects as named on Tudor's list are:

Plastic rod
Wood dowel
Bed spring
20' metal spring
Cider barrel
Metal dust pan
Styrofoam cooler
Wheel rim [the large diameter wagon wheel rim]
Copper floats [John Driscoll's toilet tank float compound object]
Glass bottle with tennis racket [John Driscoll's compound object]

Metal ring [smaller diameter wagon wheel rim or barrel hoop]
Plastic sprinkler
Metal can w/ lid
Brass bell [Ralph Jones' "Chinese bell"]
S. steel dish [stainless steel]
Metal lamp shade
Copper still
Auto wheel hub
Wood knot [a knot from a tree trunk]

Composer and critic Tom Johnson, who reviewed the performance of *Sliding Pitches in the Rainforest in the Field* for the *Village Voice*, recorded the behaviour of some of these items:

These objects, most of which were suspended from the ceiling of the old barn where the concert took place, included a wine barrel, some bed springs, a small metal ring, a plastic lawn sprinkler, a tennis racket perched on a 10-gallon bottle, a styrofoam picnic basket, a long cable which stretched diagonally up to the ceiling, and a large metal rim, which looked as if it belonged on a covered wagon wheel. [...] The wine barrel, for example, seemed happiest with low frequencies, and as one might expect, he added a deep echo to all his sounds. The little plastic lawn sprinkler turned out to be a squawky fellow, who resonated much louder than anyone his size ought to. The sounds of the large metal rim had a crazy way of spreading out all over the whole room, making it difficult to tell where they were coming from. But if you put your ear right next to the rim, or better, stuck your head inside its circle, it became quite clear that it really was the rim you were hearing. [...] There was a great variety of timbres, from the rumbles of the wine barrel, to the zinging effects of the large cable, to the whirr of the bed springs, to the extremely odd effects which happened as the sounds of the tennis racket seemed to drop into the 10-gallon bottle beneath it. (Johnson 2002, 57)

Johnson's anthropomorphism reflects the charisma of the piece, which revolves around exposition of the visual and sonic "personalities" of its objects.

Most objects listed in Figure 5-9 have one transducer, but five of them have two. Of these, two are listed as employing two transducers

connected serially, driven by one channel of amplification (the 20' metal spring and the styrofoam cooler), and the other three (plastic rod, wooden dowel and large wagon wheel rim) have two transducers driven by separate channels of amplification. In the case of the wagon wheel rim, this would have been critical for Tudor's use of a single signal source in two phase-shifted versions, as described by Linda Fisher (Fisher 2003). According to Tudor's list, the much smaller, cylindrical rod and dowel objects each employed two channels of one four-channel amplifier (each half of the amplifier notated as "J4CH ÷ 2" in the third column of the list). This was presumably to enable two different signal sources to be directed to each of these; as the rod and dowel are two of four objects apparently shared by three players (Sandifur, Palmer and Burchfield, according to another Tudor note shown in Figure 5-10), this may have been a strategy to allow more than one musician to access each object simultaneously.

If Tudor was closely following his students' work, and overseeing the detailed technical organisation necessary for presentation of the fruits of his workshop, he was equally engaged preparing his own contribution to the group performance. Notes show careful exploration of his own sound resources with specific objects: two lists shown in Figure 5-13 detail source material tested with the copper still and plastic sprinkler objects, and rated as "excellent", "very good", "good" or merely "OK" (Tudor 1973e). The fifteen different sources listed are all derived from the library of field recordings gathered by Tudor, Ritty Burchfield and Peter Poole for the 1970 Pepsi Pavilion project: the same recordings which Tudor had used in performances of *Rainforest 3* with John Cage the previous summer. The sources here can be divided into recordings of insects, birds, non-human mammals, and humans. Very few of these are direct field recordings made with air microphones; "monkey", "N.J. [nightjar] norm", "wasp", and "mos. t.t. [mosquito in test tube]" are likely to have been straightforward acoustic recordings, but the others are either heavily processed acoustic recordings ("fly mod", "wasp slo") or are entirely

electronic in nature, many being laboratory sonifications of human brain activity ("EEG", "brain wave", "alpha").

Some signal sources appear in both the "still" and "sprinkler" columns, but predictably, Tudor's sounds did not always perform equally well with both objects. "Alpha slo" is "very good" with both, but while "EEG" is "excellent" when performed through the still, it is only "OK" when heard through the sprinkler. "Br. Wave" is "good" with the sprinkler but just "OK" with the still. These source tapes had obviously not lost their interest for Tudor, even though he had used them so extensively over the previous several years; the fact that they defined the character of *Rainforest 3* did not prevent him from bringing them directly into this new group version of *Rainforest*.

Resonances and reflections

The focus of this new version of *Rainforest* was twofold, as Tudor recalled in a 1984 interview:

[...] the object was to make the sculptures sound in the space themselves. And part of that process is that you're actually creating an environment. [...] the purpose of the contact mic is to take the resonant frequencies which you hear at best very close to the sounding object; to take those into an ordinary loudspeaker which you can consider not as auxiliary but as enhancement. What that does when you establish the proper tonal balance is that you've got a reflection of the sound which you can distance in space. (Tudor 1984)

Contact microphones had been a feature of *Rainforest* objects since its first performances in 1968; the difference in the large group version is that the objects themselves are approachable, and have a substantial visual and sonic presence. Their amplified resonances, the central focus of previous versions, then become a "reflection" which does not actively

OBJECT	TRANSDUCER	AMPLIFIER CHANNEL	PICKUP	PREAMPLIFIER	MIXER CHANNEL(S)	POWER AMPLIFIER CHANNEL
PLASTIC ROD	2 X SR	J404 ÷ 2	CART	P3A	5A1	3 4
WOOD DOUVEL	2 X SR	J404 ÷ 2	CART	P3B	5B1	
BED SPRING	1 X SS	3A	2 CART	P4A	(4A1 4B1) P → 4B1	8
20' METAL SPRING	2 X SR (SERIES)	4A	2 CART	P4B	(4A2 4B2) P → 4A1	7
CIDER BARREL	1 X SS	4B	A MIC	Δ		8
METAL DUST PAN	1 X RS	5B	COST MIC	Δ		8
STYROFOAM COOLER	2 X SR (SERIES)	ST 25W (SERIES)	CART	Δ	5B2 (5A2)	4
WHEEL RIM	2 X SS	1 AB	(SE) CONTACT MIC	SE Δ		3
COPPER FLOATS	1 X SR	3 A	CART	P6A	3B1	6
GLASS BOTTLE WITH TENNIS RACQUET	1 X SS	3 B	COST MIC	P6B	3B2	
METAL RING	1 X SS	2 A	CART	P5B	3A2	5
PLASTIC SPRINKLER	1 X SS	2 B	EMPHONE KA	PSA	3A1	
METAL CAN W/LID	1 X RS	8/1	AIR MIC	Δ	2A1	1
BRASS BELL	1 X SR	8/2	CART	Δ	2A2	2
S. STEEL DISH	1 X RS	8/3	CART	P2A	2B1	3
METAL LAMP SHADE	1 X RS	8/4	CART	P2B	2B2	3
COPPER STILL	1 X SS	8/5	AIR MIC	Δ + EQ	1A1	4
AUTO WHEEL HUB	1 X RS	8/6	CART	PIA	1B1	
WOOD KNOT	1 X RS	8/8	CART	PIB	1B2	

Figure 5-9. David Tudor's master list of technical details for realization of *Sliding Pitches in the Rainforest in the Field*, July 7 1973. Reading across the page from left to right, the columns describe: object name; number and type of transducers used; amplifier channel (for signal going to transducer(s)); type of pickup used to amplify object resonances (either phonograph cartridge, contact microphone or air microphone); type of preamplifier for pickup; mixer channel(s) for pickup signals; and finally, power amplifier channel (Tudor 1973d).

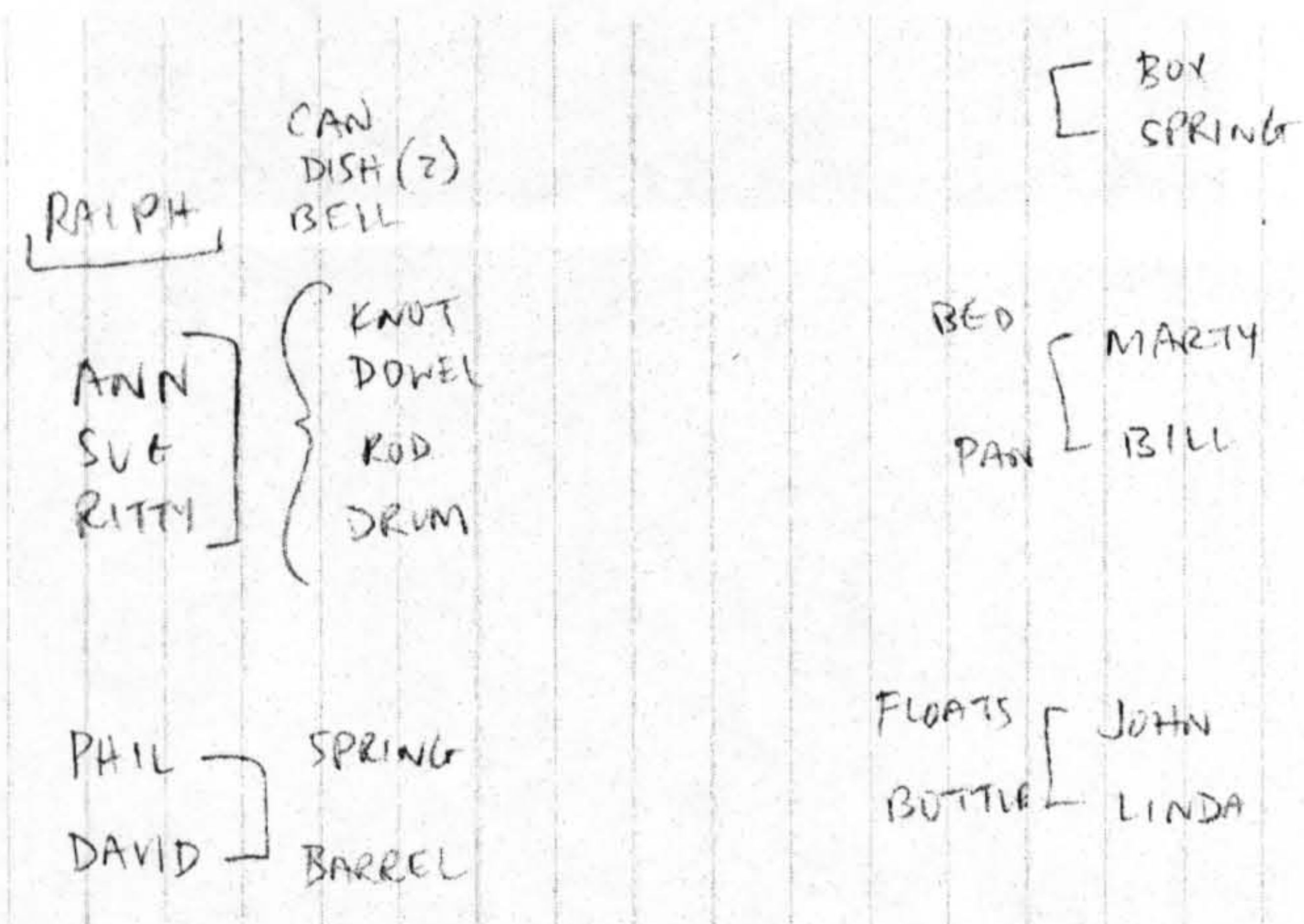
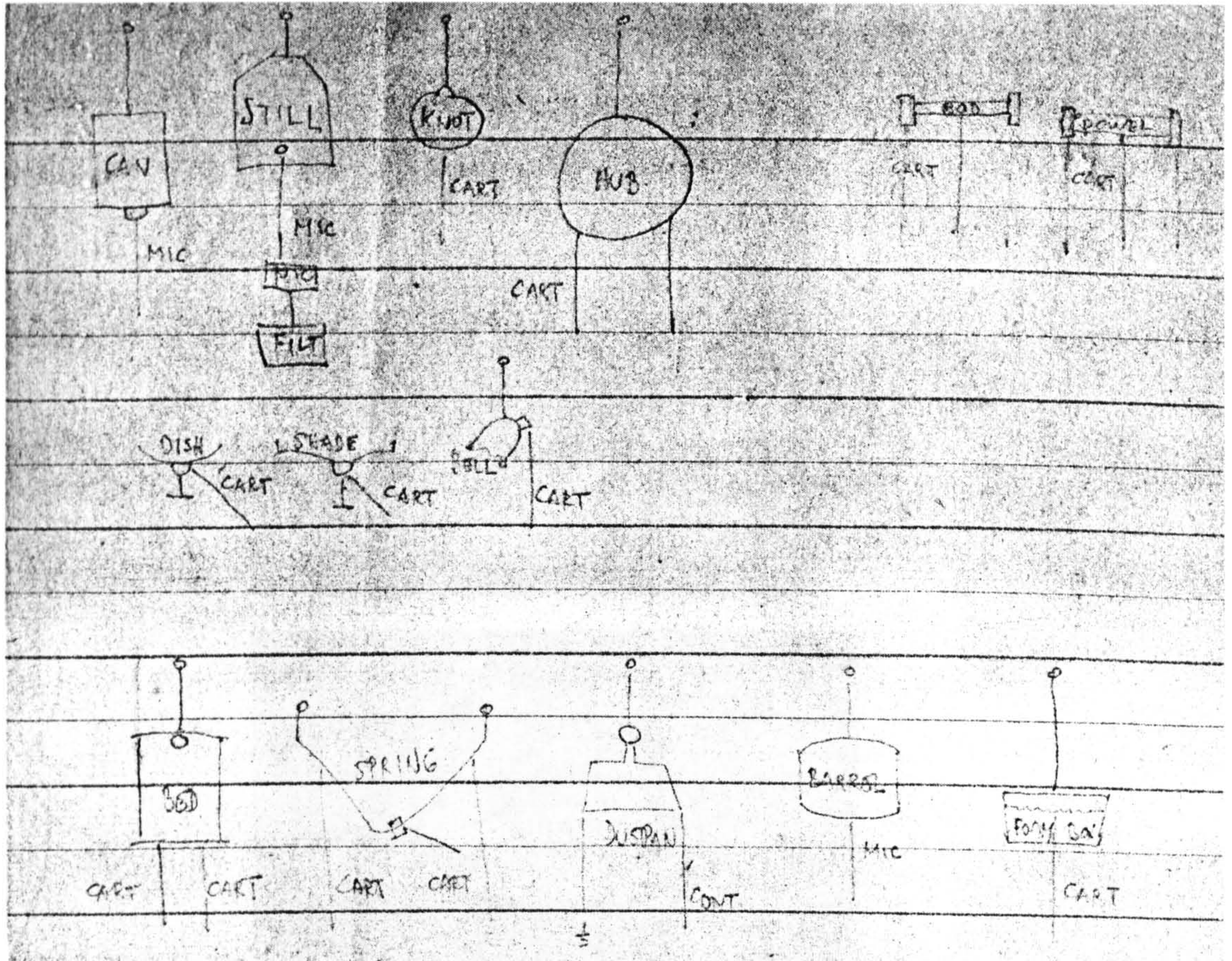

Figure 5-10. Top: David Tudor's original diagram and notes for Chocorua *Rainforest* loudspeaker-objects (Tudor 1973c). Bottom: association of loudspeaker-objects with performers (re-drawn by Matt Rogalsky from original David Tudor notes) (Tudor 1973a).

**SOUND STAR
INSTALLATION INSTRUCTIONS**

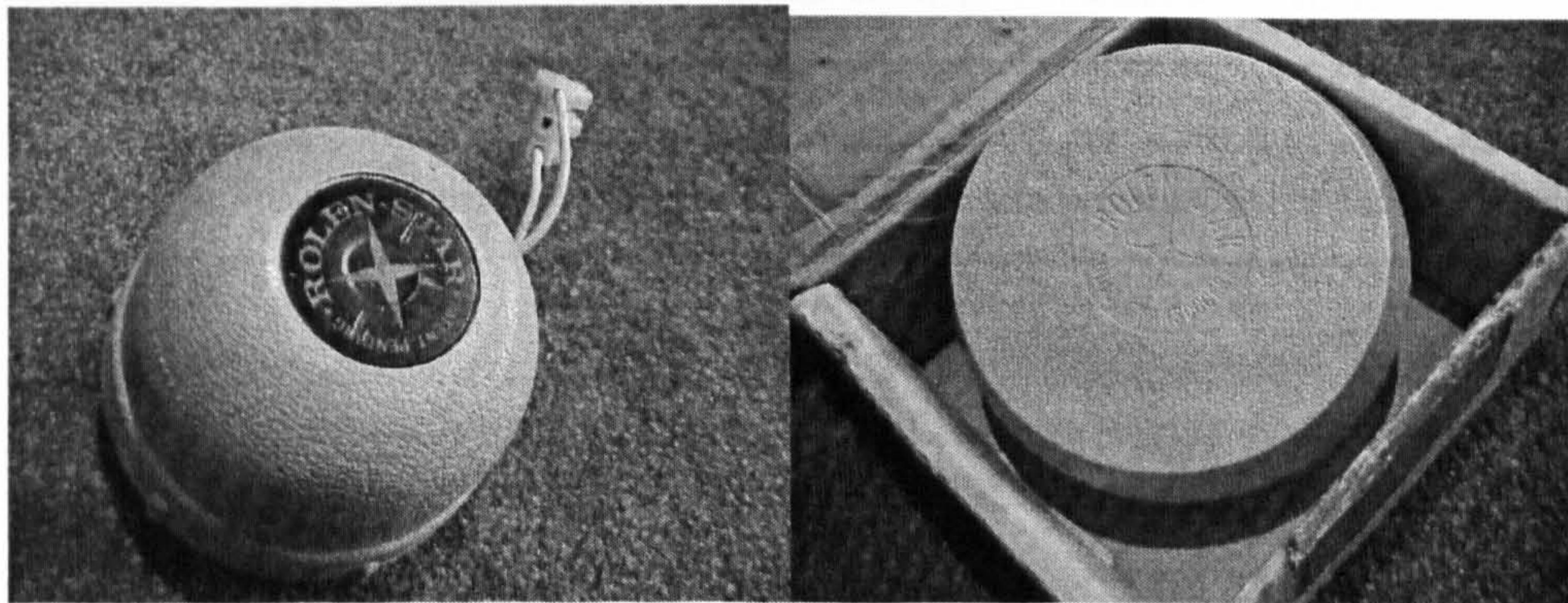
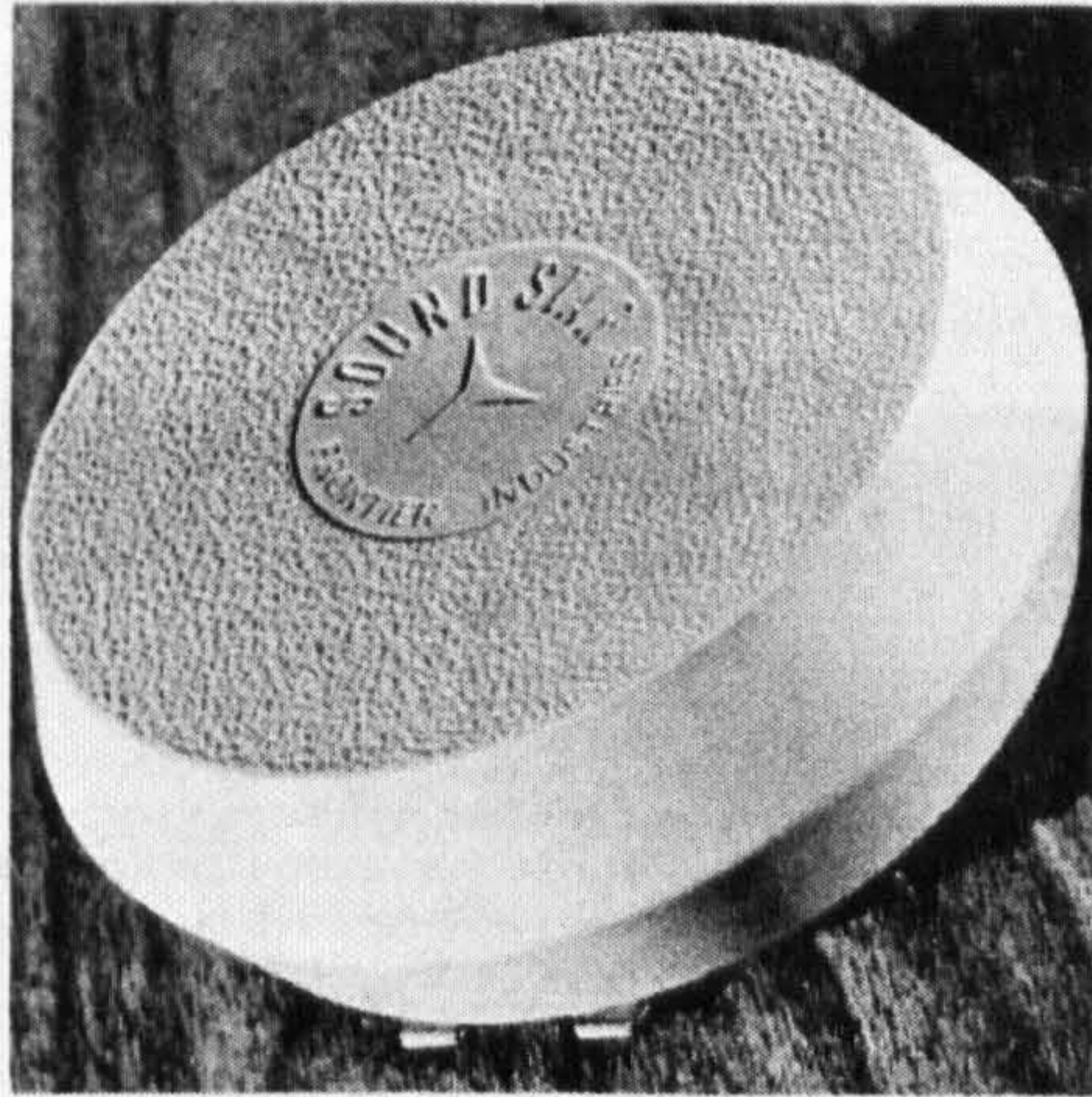

Figure 5-11. Three makes of audio transducer identified by abbreviations in Tudor's notes for Chocorua *Rainforest* objects. Top: "SS"—Frontier Industries "Sound Star" (Photo from installation manual). Middle: "SR"—Ashworth/Lafayette "Sound Reproducer". Bottom: "RS"—"Rolan Star" in earlier and later versions, with the later one visually almost identical to the "Sound Star" (Photographs by Matt Rogalsky, 2001).

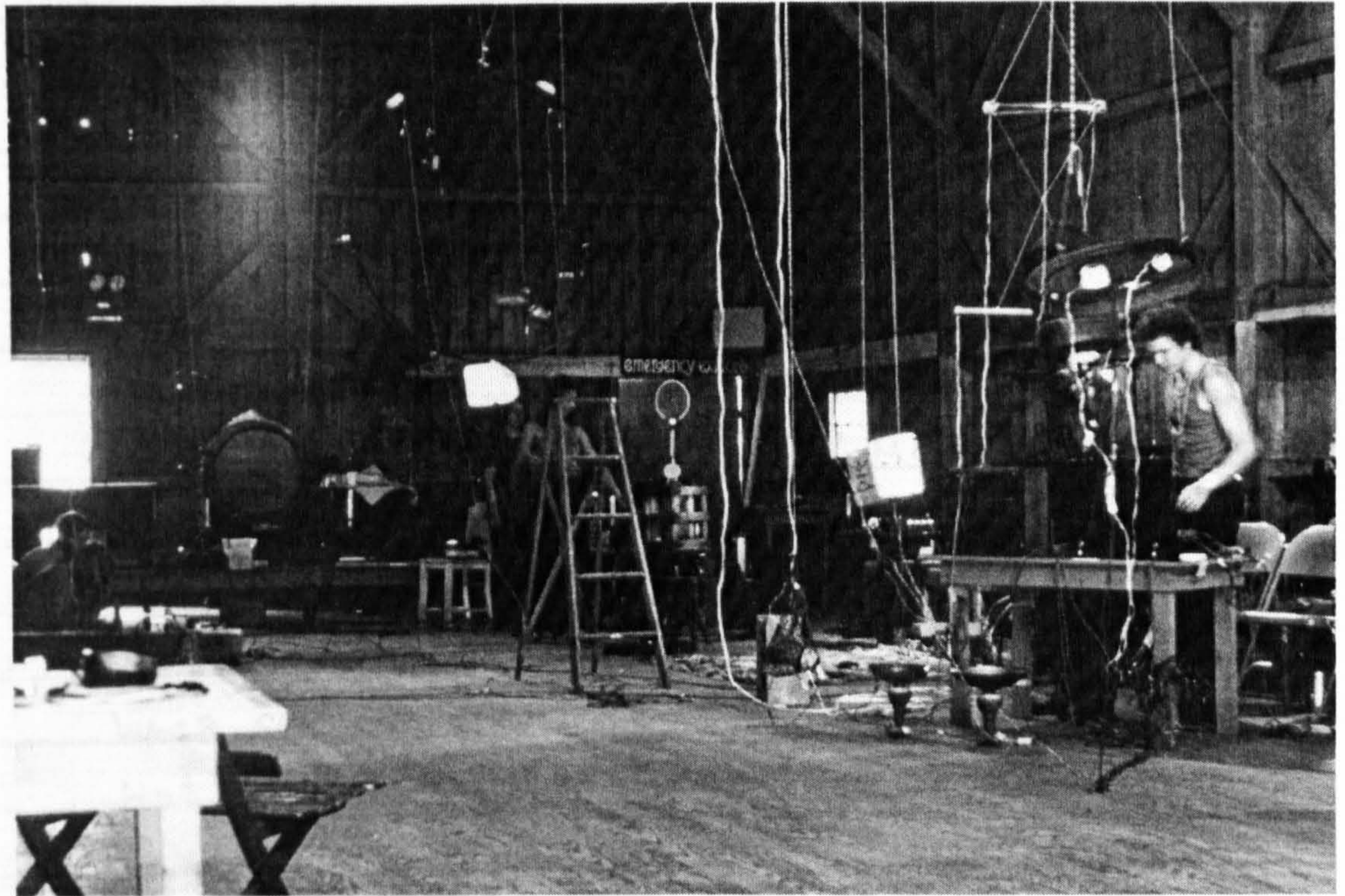

Figure 5-12. Another view of preparations for *Sliding Pitches in the Rainforest in the Field*. People, from left to right: Martin Kalve, Bill Viola, Linda Fisher, unidentified woman, David Tudor, Ralph Jones. Photograph by Petr Kotik, 1973.

STILL	SPRINKLER
3000-Ω C.M. - filter - IC →	Hi-Z phone → IC →
INSECT EXCELLENT	MONKEY OK
MONKEY GOOD	N.J. SLO GOOD
N.J. NORM GOOD	DEMOD ALPHA GOOD
WASP GOOD	ALPHA SLO VERY GOOD
ALPHA SLO :VERY GOOD	EEG VERY GOOD
EEG EXCELLENT	BR. WAVE SLO GOOD
ALPHA NORM VERY GOOD	FLY MOD OK
FLY MOD VERY GOOD	BAT GOOD
BAT VERY GOOD	BR. WAVE NORM GOOD
BR. WAVE NORM OK	MOS. T.T. NORM OK
WASP SLO OK	
MOS. T.T. NORM GOOD	
B. WAVE 1 ⁷ / ₈ VERY GOOD (EXC. ACOUS.)	

Figure 5-13. David Tudor's notes on source material for copper still and plastic sprinkler loudspeaker objects for *Sliding Pitches in the Rainforest in the Field* (Tudor 1973e). Both objects used high-impedance air microphones for pickups (identified at top of list). All sound sources listed belong to the collection of field recordings which Tudor gathered during the 1970 Pepsi Pavilion project, and subsequently used for performances of *Rainforest 3* with John Cage in 1972.

draw attention to itself but instead plays a supporting role. Tudor says that with this support the piece "becomes larger and there's a coherence there that's deceptive which I like very much, because as you move through the space there are sounds that you hear, that you've heard before or have heard somewhere else" (Tudor 1984). The returning signals from the object pickups "have a different kind of sound than the object does when you listen to it very close where it's hanging. It becomes like a reflection and it makes, I thought, quite a harmonious and beautiful atmosphere, because wherever you move in the room, you have reminiscences of something that you have heard at some other point in the space" (Tudor 1988a).

Although the balance of sounds in *Rainforest 4* may be constantly changing, sounds introduced into the piece tend not to leave very quickly; on its first performance at Chocorua, critic Tom Johnson remarked: "The individual effects were largely repetitious, many having a rhythmic pulse, but the situation was constantly changing. Every few minutes some object would fade out and another one would come into play, and the process kept me interested for a couple of hours" (Johnson 2002). This slow pace of change makes it possible for a *Rainforest 4* visitor to experience what Tudor describes as a "reminiscence" of a sounding sculpture: if one interacts with a *Rainforest* object at close range, listening to it carefully, perhaps even touching it (or listening to it with a stethoscope, or via bone transduction by actually *biting* the object, as *Rainforest's* musicians have been known to encourage people to do), one gains a familiarity with that sculpture. Afterward, when moving around the exhibition space, the sculpture is likely to continue to sound in the same "mode" for a time, before its performer decides to modify its source signal; the listener then has time to encounter its "reflection" by chance, perhaps emanating from a completely different point in the room.

Tom Johnson's account of entering the barn at Stafford's-in-the-Field at the start of the performance of *Rainforest* is an interesting one:

At first I thought the sound was all coming from the few conventional loudspeakers at the sides of the room and that the hanging objects were décor, but it soon became clear that the objects themselves were vibrating. No program notes were provided, but people began to discover that if they placed their ears inside the wagon wheel rim, for instance, they would hear a world of sound they had never experienced before (Johnson 1975).

The placement of *Rainforest 4*'s "conventional" sound system, the speaker network which provides the "reflections" of the sounding sculptures, has often been overlooked, or only briefly mentioned; even in recently published thumbnail histories of *Rainforest 4* (Driscoll and Rogalsky 2004), the matter of how to amplify the resonances of the objects via their contact microphones seems to be taken for granted. Much attention is paid to sound sources, the development of the sculptural loudspeakers, and matters of creating a visual environment, but the sound reinforcement which makes the piece "larger", according to Tudor, is neglected, perhaps because it is the most "ordinary" aspect of *Rainforest 4*. Conventional amplifiers and loudspeakers may seem uninteresting, hardly worth mentioning, beside the more exotic topics of loudspeaker-sculptures and their varied sound sources.

The most important feature of the conventional sound system which "fills out" the sound of *Rainforest 4* is that it be placed so that its sound comes to the audience indirectly. This seems to be a constant from installation to installation: the speakers are usually placed "facing them up and into the ceiling", according to Ralph Jones (Jones 2001). This creates a wash of sound, rather than a number of pinpoint, easily located sources. The "tonal balance" (Tudor 1984) between the acoustically sounding loudspeaker-object and its mirrored reflection in the indirect conventional loudspeaker then becomes of critical importance. Even within the group of musicians who worked closely with Tudor on *Rainforest 4*, the balance between the acoustic and amplified elements of the piece was apparently difficult to find:

I wish to God that my performers could understand that [the importance of "tonal balance" between the sculptures and their "reflected" sounds], because they get so carried away with the fireworks that can happen in the sculpture itself that they don't pay attention to the tonal balance. And when you've got like six people all doing that, it can get pretty wild. It's at its best when it remains calm. (Tudor 1984)

The indirect sounds of the acoustic objects have been described as a "cloud" suspended over the installation of *Rainforest 4*. Sound from upturned loudspeakers (or, in some cases, loudspeakers actually located above the heads of the audience) reflects off the ceiling and walls, to create a lush reverberation. In the barn at Chocorua, recalls Linda Fisher, "we had a sound system set up and we had it all around the top lofts, the lofts of the barn, so that there was something coming at every level" (Fisher 2003).

An argument has been made by Ralph Jones that the indirectness of the "object reflections" in fact works against Tudor's own desire for visitors to "walk past a loudspeaker and hear [...] a memory of something that they experienced before, having been close to an object"; that the sounds conducted by pickups on *Rainforest* sculptures have been "underexplored and underexploited" (Jones, 2001). Jones, whose work in designing *Rainforest* compound objects has shown a strong interest in means of focusing sounds, and who in 1978 participated with other members of Composers Inside Electronics in a focused loudspeaker design project, argues that "to have a full-range, very clear, very crisp and beautiful reproduction of the contact sound adds a whole other dimension to the piece" and that this crispness is unattainable with indirect loudspeakers: "if you point them into the ceiling you lose all the highs first of all, so you're only dealing with lows" (Jones 2001). Jones speculates:

We always faced the loudspeakers away from the performance space and up into the ceiling. And I've always had a nagging problem with that. [...] maybe part of that strategy was to try to avoid

feedback? And feedback is obviously a really difficult problem in *Rainforest*. Like I had that milk can, I had an air microphone suspended down in that milk can. Now you know, Helmholtz resonator—as soon as you bring it up, there it goes! And you're dealing with resonance all the time, all the objects are resonant, so you're always at that point where if you bring it up a little too much, you're going to get feedback, it's inevitable, it's a resonant system. It's highly resonant, it's a lot more resonant than a mic and a speaker in the room, you know, it's really resonant! But if you can exercise mature control over that system and use it judiciously—and what I think we've been learning over all these years is how to do those things judiciously—then I think we could really achieve what David actually wanted from the speakers, and what in my opinion we never actually got. So this is another area where we can continue to take *Rainforest* to the next level, and bring it closer to what David's ideal was. And enhance it, and contribute to the culture of *Rainforest*. (Jones 2001)

The goal in creating an indirect "cloud" of sound reflecting the soundings of the objects is, in my mind (writing as participant-observer, having taken part in a number of realisations of *Rainforest* since Tudor's death in 1996), a way to provide the type of memory experience Tudor imagined, without calling attention to the conventional loudspeakers which provide the "cloud". If less indirect speakers were employed, the quality of the "reflected" sounds would be improved, but that might be at the expense of taking some of the focus away from the suspended, sounding objects. The conventional loudspeakers might then be playing a co-starring, rather than supporting role, and this might work against the piece. But as Jones says, "there are all of those interpretive questions [...] I think *Rainforest* may be unique among musical works in that it admits of an extremely broad range of inputs and a broad range of interpretations while at the same time always retaining its essential character. You always know it's *Rainforest*, just like you know it's that Bach cantata or that Mozart piano concerto, or Berlioz' *Requiem*, or whatever" (Jones 2001). The qualities of *Rainforest*'s "reflections" are inevitably somewhat different from installation to installation, and despite the development of a "conventional" means of returning sounds from the objects, the work remains open to experiment and change.

Developing sound sources for *Rainforest* objects:
the "natural" and the "artificial"

We have already seen that, at Chocorua, "live electronics" played an important role as sound sources for *Rainforest*, via circuits created in workshops led by Gordon Mumma and David Behrman. Some students came to the workshops already equipped with their own elaborate gear: John Driscoll recalls bringing "a bank of oscillators" (Driscoll 2000a), and Bill Viola recalled Driscoll's "little boxes that were actually chirping like crickets" (Viola 2000); Gregory Kramer brought a large analog synthesizer incorporating numerous modules sold commercially by Buchla and Electron Farm (Kramer 2005a). Ralph Jones at the time was "fascinated with the sounds that I could find using shortwave radio" (Jones 2001) and employed some of these with his objects, during Tudor's workshop, while Linda Fisher says that "about 75 percent" of her sound sources were "tape-based, because I loved acoustic sounds and would go out and record" (Fisher 2003).

As his notes show, David Tudor himself relied heavily on his Pepsi library of field recordings. Bill Viola also recalls that "my situation there really was all tape"; for him, Tudor's field recordings played through his loudspeaker-objects represented "nature meeting nature" (Viola 2000).

Tudor had this amazing library of natural sounds he had collected for the 1970 Osaka World's Fair. [...] I remember my favourite one was the seals out in the ice, it was one of the greatest recordings, it was like some kind of hallucination of a gathering of the spirits, howling underwater. That was the most spooky, chilling, goose-pimple-like thing I've ever heard.

I was starting to do circuit design, I was starting to make my own oscillators and sound things, the 741 op amp and all that stuff. Part of me was interested in that, part of me was a little ambivalent, and then here are these natural sounds which sounded, not only like a lot of the electronic sounds which I was interested in trying to make, but better. Because they had content, basically. The fact that it was

seals, to me, was important, as opposed to just howls, which I could make with different circuits I had. (Viola 2000)

Viola remembers Tudor "also used some purely electronic sounds, in addition to these very profound sounds" (Viola 2000); this passing contrast of the "profound natural" with the "profane artificial" (my words) suggests much about ongoing, fascinating tensions within *Rainforest* as to the ambiguous identity of its sounds. In this new group realization, where any sound source was permitted, with the exception of "previously composed musics"—that is, music composed for another occasion—electronic and acoustic signals mixed freely, drawn from many different sources. After passing through the *Rainforest* loudspeaker-objects, the electronic and acoustic sources are so effectively filtered that, if they ever could have been told apart, they then, more often than not, cannot be.

"In terms of sound processing, it's a pretty simple thing", says Viola.

It'd be like if you gave someone, like, five different kinds of equalizers set in this weird kind of way [...] but it's more than that, it has this resonance thing that's one of the keys, it has this moment of excitability. And it's something Tudor did stress, that it was really when the sound going in was not the sound coming out, when the sound coming out was really transformed, that's what you were sort of searching for. So you have this array of material, and it was guiding you beyond Tudor, when the objects resonated, and added all the resonant frequencies, some of which weren't even in the original sound, they were like multiples and harmonics and things, and you got back this ringing from, like, these frogs that went in, then that was it and you went to another source and experimented with that. And so in a way it was telling you that it wanted to transform the sound—like there was a direction mechanically contained within the materials themselves that was guiding us also. (Viola 2000)

As previously mentioned, David Tudor's conception of himself and his work—including his entirely electronic works—as being essentially part of "nature" means that the apparent difference between the two "polarities" (acoustic/electronic, or "natural"/"artificial") might be thought of as an

unnecessary distraction in coming to an understanding of *Rainforest 4*.

Ritty Burchfield remembers visiting Tudor at his home in Stony Point, NY:

All around his house there were lots of plants and things and bugs. And I just remember sitting there listening to bugs and birds and things and it was very much like being with the headphones, thinking about the different sounds, or hearing the different funny sounds and it would make you kind of laugh or get your attention one way or the other. And I think that was very much what he envisioned in a lot of it – sort of the ambiance of the signals. And we used to talk about trying to crack the code of hearing all these different rhythms and things like that and we just thought if you listened long enough you could hear...you know, you'd get the message of the nature and birds and the bugs and things like that. And, of course, mechanical things [by "mechanical things" Burchfield here includes the realm of electronic devices] were accepted as well. (Burchfield 2001)

In *Rainforest 4*, then, the confusion of signals arriving at the ear of the listener, with the mystery of their origin, the collapsing of "natural" and "artificial", might be thought of as Tudor's most explicit exposition of his conception of nature, and his relationship to it (or rather, his existence within it). Tudor said: "it seems to me that the way I use the technical medium, it's just more of what's already there" (*Experiments in Art and Technology* 1977). In *Rainforest*—all its versions, but perhaps most strongly *Rainforest 4* which admits all possible signal sources—the blurring of boundaries between the "natural" and "non-natural" is a primary outcome, even if the project was not begun with that explicit goal.

Despite Tudor's injunction against "pre-composed" musics (or perhaps, because of it), on one occasion following Chocorua, Bill Viola made a clear transgression, for humour's sake: through a large oil drum he projected a recording of Aretha Franklin singing *Respect*. Linda Fisher recalls: "it was so hilarious, because a particular part of that song would always emphasize this deep, sort of tube-like tone that the oil barrel would give off. That was just, you know, one of those priceless moments. And I think he actually brought it again when we did the Judson [Tudor's

memorial in 1996 at the Judson Church in New York City], just for old time's sake" (Fisher 2003).

Sliding Pitches in the Rainforest in the Field

The first performance of *Rainforest 4* on July 7 1973, under its portmanteau title, ran for five and a half hours. Tom Johnson wrote:

The situation was informal, so that the audience could mill around and explore these objects. It was fascinating just to poke around and figure out what was doing what, and the sounds were appealing in their own right. [...] They [the performers] were not trying to press the point, as people were free to come and go at will. They just seemed to enjoy keeping the sounds going for those who wanted to stay, and for those who would come back later on. I suppose they were also having an enjoyable time feeding various sounds into various objects, testing how the objects responded to different things, trying to find resonant frequencies, and listening to subtle variations.

David Tudor began the performance as a soloist, playing sounds which he had prepared the evening before, through the large wagon wheel rim. As has already been mentioned, according to Tudor the decision to begin on his own was deliberately taken "in order to protect myself"—to "set the tone for anything else which came" and thus protect the integrity of the piece (Tudor 1995).

Linda Fisher and Bill Viola had climbed up into the uppermost levels of the barn, awaiting the start of Tudor's performance. Fisher's description of the experience of hearing Tudor begin is worth quoting at length, not only because it evokes the character of the place and time, and the sonic qualities of the piece, but because it begins to describe a deep sense of connection and commitment which Fisher, Viola and others had begun to feel towards David Tudor and *Rainforest*. Fisher and Viola perhaps felt this most strongly, but many of the other six core members of Tudor's group also expressed similar feelings towards him and his work, on other

occasions. This will be explored further in Chapter Six, which deals with this group, that came to be known as Composers Inside Electronics.

Linda Fisher's description of the beginning of *Sliding Pitches in the Rainforest in the Field* is as follows:

[...] you could climb up to different lofts and hear it at different points, so Bill Viola and I went to the very top loft of the barn, because David always insisted (especially at the first performance like this) that he begin. He wanted to give us a sense of how to begin the work and to get a feel for how it should be. So he was going to perform for a while and then he would sort of beckon to us and we could join in. Because his thought was that we would all start at once and it would be really loud and raucous, which, in fact, it was sometimes the first few performances. And anyway, Bill and I went up into the loft and waited for it to begin. And it was a very, you know, festive atmosphere and, you know, it was summer and people were vacationing and everyone was relaxed and there was lots of, you know, alcohol flowing. So David began, and he began with this wagon wheel rim. And he began acoustically and you could hear it way down below drifting up and I really had never in my life heard anything like it and hadn't experienced anything like it. I mean, I had listened to John Cage's music. I listened to a lot of new music—I was attracted to it—but I never heard anything like that and I never felt a response emotionally to something in that way. And so he was doing that and gradually began bringing the loudspeakers into it. And for me at that moment, it was such an overwhelming experience. I mean, I just first of all didn't know what I was hearing, I didn't know where I was. I had never felt an emotional response to music the way I did at that moment and I just burst into tears—I was just sobbing and crying from the impact of it. I mean, not only the physical impact of the sound waves themselves...you know, which for David's music is such an essential component. You don't just hear it, you feel it—your whole body feels it and absorbs it. So that was going on. But then I really felt that an emotion was opened up in me that I had never known before. [...] gradually I sort of gained my composure and we made our way down and started joining in and everything was fine, but I think [...] that really sealed it for me and I had my understanding of where David was coming from, even though it was a very hard thing to articulate. (Fisher 2003)

Bill Viola has also written about this experience, in very similar terms. Oddly enough, Viola recalls the occasion as a Tudor piano recital, although Tudor did not give an evening piano performance (or any other

public piano performance) during the course of New Music in New Hampshire. Petr Kotik is quite clear about this: "David Tudor did not play the piano at Chocorua. In fact, it was quite shortly —two to three years—after he told Cage that he is not going to play the piano any more, that he should find another collaborator. I doubt that he would have liked to play the piano in public at that time" (Kotik 2005c). Viola's two accounts of the experience are, however, otherwise so close to Fisher's that they seem clearly to refer to the same episode—the opening minutes of *Sliding Pitches in the Rainforest in the Field*.

We climbed up on the top of the rafters of the barn in Chocorua in '73, when he [Tudor] was doing a solo performance—the first time he'd played piano in a long time. And we were so excited. And at one point in the middle of the performance there was so much stuff coming out of David, non-physical stuff, pure spiritual energy. I don't want to sound flaky or new-agey here, but that's all I could describe it as. You were just incredibly aware that what was coming off him was more than just music. And Driscoll didn't see it, and other people didn't see it, but I looked over to Luffy [Linda Fisher] over there, and she just went [makes gesture of understanding]. You know, at the moment when it was so intense, he was hardly moving at all and you just felt like there was this emotion in the air, so thick. And Luffy caught it, and we just looked at each other and afterwards she said "Did you see that? Did you believe what David was doing?" And of course everybody else was talking about the music [laughs]. But it was so powerful. I'll never forget that. I had the feeling I could see waves of colours, as if you could see the soundwaves shooting out of him. There was something deep there. (Viola 2000)

[...] the most personally memorable [experience at Chocorua] turned out to be David's evening solo piano performance, apparently one of the first on the piano that he had given in some time. Linda Fisher and I climbed up into the loft in the barn and watched and listened from the rafters like two barn owls. We had become close during the workshop, kindred spirits searching for something a bit more immaterial and essential beneath the technical, intellectual and somewhat competitive atmosphere of a music camp.

Tudor began. Everything seemed "normal" at first, an avant-garde music performance by a highly skilled and accomplished virtuoso, impressive to be sure. Then something else took over. David changed. The music changed. It felt as if his mind had taken hold of the room, moving out into the space and into us with every sound

and silent pause. It was invisible, dynamic, palpable and physically present, and it rose and fell like waves on a sea of emotion. I looked over at Linda, and one look back from her told us both that we were witnessing the same thing. We wept. (Viola 2004)

Linda Fisher said of the workshop series as a whole, "It was so engaging, that whole three weeks. I mean, we were just going at this very high, intense level the whole entire time fuelled by ouzo and tequila and all of our favourite lubrications. So there was just that spirit of discovery and you could just see the piece growing and beginning to take on a new life, or another life" (Fisher 2003). A letter which Fisher wrote to David Tudor, immediately after returning home to Ithaca from Chocorua, is a further illustration of the depth of her experience, and the resonance of *Rainforest* within the group:

I thought about you all day
so after work
I went to Tung Fongs
to get you this present
You may not need it right away -
but some day when a bunch
of you are drinking Tequila
it may be good to have around.
On the last night in Chocorua I
was trying to figure out how
I could say thank you to you
for blowing my mind
but we all got so blasted and it
seemed unnecessary then -
anyway I arrived home only
to find myself in some crazy new world.
I would welcome any chance to
work with you again perhaps on
a more strenuous level. Is that
impossible? I don't care much for
letters, I would prefer to be drinking
with you at this moment. Also assuming
the big hoop has arrived safely and is living
in your shed? Love to you, Luf

(Fisher 1973)

These stories of ecstatic experience contain the kernel of the roles David Tudor was to take on with the core group of younger musicians made up of Viola, Fisher, Edelstein, Driscoll, Jones and Kalve. As Phil Edelstein described him in his notes, following Tudor's death: "Friend, colleague, teacher, master, collaborator" (Edelstein 1996). At the same time, while he was clearly the senior artist and gave the group focus, Tudor's leadership was not of a particularly pushy nature, and although he strove to foster and develop the individual work of his "apprentices", the master/student relationship was a loose one and Tudor did not demand adherence to any particular dogma; rather he seemed pleased to have the association of this group of energetic young composer/performers who enabled him in as many ways as he was able to assist them. A large part of the experience of the group was purely social, and not musical: as Ralph Jones said, with tongue in cheek, "David never led the group, unless it was to a particularly good restaurant" (Jones 2001).

The development of this core personnel into the ensemble Composers Inside Electronics, which functioned as a floating *Rainforest 4* touring group, a performance ensemble for "classic" experimental works by John Cage and others, and a cooperative for performing works by members of the group—with Tudor as nominal guru—is the subject of the following chapter.

To conclude this chapter, however, it would be worthwhile to look at the immediate aftermath of Chocorua '73: the fate of New Music in New Hampshire, and the brief flourishing of the group "Pnumbral Raincoast" which in several ways paralleled and prototyped Composers Inside Electronics. Pnumbral Raincoast began as an attempt to keep the alumnae of the 1973 Chocorua workshops in contact via a mail network, and to brainstorm ideas and join forces to produce concert events of their own and others' new music. Described by Phil Edelstein as an "amoeboid outgrowth of New Music New Hampshire" (Edelstein 1975), it was a vibrant but relatively short-lived experiment, and involved all six of Tudor's core group in addition to many of the other Chocorua students.

Controversy and aftermath

Although New Music in New Hampshire seems to have been generally judged an artistic success by the participants I have interviewed, it did not pass without controversy. Ann Sandifur wrote a lengthy, stern review of the workshop series for the periodical EAT (no relationship with the organisation Experiments in Art and Technology), published in Oakland, California, describing it as "that strange alchemy of music making turning back into life making" (Sandifur 1973) and going on to state that the men responsible for organising the workshops "scheduled a full week of concerts and planned the courses to climax with the concerts. What they neglected to envision was that orgasm comes with the needs of the people and that the male idea of the their [sic] time to come could not be imposed on the group as a whole" . A straightforward description of each of the workshops follows, with these notes on Tudor's contribution: "David Behrman and David Tudor had the least structured classes as the people building electronic circuits or transduced objects were free to work at any time while the two Davids served mostly as advisors. David Tudor's class was based on his piece RAINFOREST in which objects such as cans and metal hoops were caused to resonate and thus act as speakers. This piece or process encourages the exploration of sounds inherent in objects" (Sandifur 1973).

The student/staff hierarchy was highlighted by Sandifur, who noted the "regressive" segregation of faculty/administrative staff who were given rooms in the inn, and students who were billeted in cabins, separated by sex, which "presumed completely heterosexual behaviour on the part of all those who came". These problems, and others caused by "compartmentalization of human lives" in the workshops' scheduling of daytime workshops and nighttime performances, were judged to be in part a failure to include any women as faculty.

I say this because there is something in the female point of view, if I may use that expression, that because of their particular political position and their potential for a nearness to living processes they promote an affection for living associations and processes rather than an affection for objects and formalized structures. [...] when I passed around a petition indicating that those who signed it would be less interested in returning to Chocorua if there were no women faculty everyone but the Artistic Director, Petr Kotik, signed it. (Sandifur 1973)

The petition, as reprinted alongside Sandifur's article, is shown in Figure 5-14.

Petr Kotik says that immediately following the first workshop series, he already had "exact plans" for a second year of workshops, and that some artists had already tentatively agreed to come, among them composer La Monte Young and his artist partner Marian Zazeela, theatre director Robert Wilson, and sculptor Richard Serra (Kotik 2005b). Instead, he abandoned New Music in New Hampshire following the submission of a letter to the organisation's board of directors by Gordon Mumma on behalf of a new committee struck during a weekend get-together of Chocorua '73 faculty, alumni and colleagues in Albany NY on August 19 and 20. This group met to constitute themselves as a "program committee" for New Music in New Hampshire, Inc., "in accord with the by-laws of the board, in order to advise the board concerning plans for next summer's gathering" (Schwartz 1973a). The committee included 17 people, among them David Tudor, Gordon Mumma, David Behrman, Bill Viola, Linda Fisher, Ralph Jones, Phil Edelstein, John Driscoll, and Julie Schwartz (Mumma 1973b).

The changes proposed by Mumma and the new committee mirrored some of the feelings expressed by Ann Sandifur ("Terms like student, faculty and the like do impose a sense of hierarchy and do not illuminate anything else of use" (Mumma 1973b)), although the importance of women faculty was not specifically addressed, and an attached list of "suggestions for Program Committee and/or invited artists for 1974, collected at the meeting in Albany, 19 Aug 1973" included only one

woman out of 28 people named (this list was an addition to an earlier list of 30 suggested names compiled and submitted to the board of New Music in New Hampshire by Mumma, of which eight were women (Mumma 1973)).

Petr Kotik responded to the Albany program committee's correspondence with a courteous but terse letter outlining his concerns with the "lack of identity and independence" in the group's apparently unanimous voice, and criticising what he viewed as its desire to bureaucratise New Music in New Hampshire, Inc., which in his conception was meant to be guided entirely by the decisions of the organisation's Artistic Director, approved by its board: "Nobody is going to take my ideas and realize them for me", Kotik wrote. "I am the only one who has to do it [...] The Artistic Director, of course, is taking advice of many different people as well" (Kotik 1973). The letter concludes by congratulating the Albany group for their initiative in organising the August 19 meeting, but questioning why they found it necessary to attempt to work within the existing New Music in New Hampshire organisation, instead of founding a new organisation structured from the ground up around their ideals: "Are you afraid of going ahead independently, building up an organization with which you can fully identify yourself? I hope not" (Kotik 1973). The letter concludes by rejecting compromise of Kotik's ideals for New Music in New Hampshire, and withdrawing from the organisation while wishing its program committee well.

^{never less}
 The women of New Music in New Hampshire or Chocorua '73 take exception to the lack of women composers in residence (faculty) and are ~~not~~ interested in returning for another such session if there are no women composers in residence. We would suggest Some ~~more~~ women ~~composers~~ in residence.

Ann Sandifur	John D. Dubelet
Susan D. Palmer	John C. Merrill
Betty Burchfield	Gregory
Julia Schwartz	Ralph Jones
Julius Eastman	Robert Johnson
Frederic Renski	Martin Calver
Richard Poggi	David Reites
Frank Abbott	Alan Taza
Don Rubin	Richard R. Kelly
John Jewell	Chris Burch
Robert Krum	Phil Eddies
Nancy Caldwell	Susan Stover
Tom Bergeron	David Schuman
	Phil Harmonie
	Kurt Weyner
	Bill Viola
Katherine Maloy	Charlotte Keel
David Tudor	

Figure 5-14. Copy of Ann Sandifur's petition regarding the lack of women faculty at Chocorua '73, signed by most students and staff members of New Music in New Hampshire, as printed alongside her review of the workshop series (Sandifur 1973).

New Music in New Hampshire, Inc., appears to have suffered a speedy decline following these exchanges. In mid-autumn 1973 Julie Schwartz wrote all the parties involved with an update, stating:

The board of NMNH is in disarray and probably collapse. Gordon, Petr and Allen Sapp haven't resigned yet, but a viable compromise isn't likely. Only alternative now proposes to make the board an umbrella organization for several different and separate projects. (Schwartz, 1973b)

Plans for the summer of 1974 were still brewing, however, but on a more idealistic, communal level:

[...] an informal gathering of our own group seems most appealing and practical--a kind of ongoing intense collaboration/composer's forum/workshop--designed for ourselves. No one will be paid to come (there'll be no teachers or hierarchy), little or no, if any, publicity, and our moneys will go to our own support. In other words, a HERMITAGE, for about 3 weeks, where pieces/events are developed in an informal, unpublicised atmosphere--to be followed possibly by a CITY TOUR, set up in advance. [...] Extra equipment, if used individually, will be paid for privately and then kept by the person--for instance, last summer, David T brought ALL that equipment, but at the end, we needed to dismantle instruments--anyway, we can work all this out. (Schwartz 1973b)

Linda Fisher, for her part, wrote to David Tudor a letter expressing frustration and misgivings with the attempts to continue New Music in

New Hampshire into 1974:

Now I feel one big COMPLAINT --> NMNH. I've never gotten such a steady flow of mail - and none so BORING. I would scream but I did that once in NH about all this craziness. [...] Neglecting Ch. '74 - speaking only of "our" attempts to organize permanently - I think I would rather see a future create itself out of any natural magnetism that existed among us all rather than derive a structure or administration from all the unfortunate aspects of Ch. 73. This organizational mania has its largest basis in anxiety and insecurity.

Possibly I am unfair in saying so - Organization can be useful and even very purely conceived but I think it is a crutch of sorts here. I suppose I am a useless anarchist. The Rainforest project began a very strong life of its own for many reasons - its 'organization' began from within itself. (Fisher 1974a)

Pnumbral Raincoast

Julie Schwartz operated as a clearinghouse for information, by not only keeping the new program committee's membership informed on the current status of New Music in New Hampshire, and distributing ideas for a gathering in 1974, but also by re-distributing mail received from the membership containing comments, thoughts, plans and ideals for the group, which was quickly receding from New Music in New Hampshire and beginning to seek its own identity. Schwartz received mail from the geographically distributed members, and photocopied multiples of everything for re-mailing to the entire group. One of her letters concludes: "P.S. To help the xerox crew, maybe try to squash your letters together-- for fewer pages" (Schwartz 1973b).

Proposals for the group regarding its identity and potential projects came quickly from the dispersed membership. Phil Harmonic (a.k.a. Kenneth Werner), a Chocorua alumnus based in California, sent a postcard exclaiming "dear Julie, your mailings are great! i will be sending you some things to xerox soon but i definitely have some proposals re: documentary/ environmental real things people might care to do" (Harmonic 1973). Ralph Jones and John Driscoll each wrote long letters detailing their thoughts on the group's identity and possible activities.

"We really should have a name", wrote Jones on September 3 1973, suggesting a term drawn from the invented religion "Bokononism" in Kurt Vonnegut's 1963 novel, *Cat's Cradle*: "karass", defined as a team of people which does "God's Will without ever discovering what they are

doing" (Jones 1973). Jones also related that "Sue" (perhaps Susan Stenger, who was part of the Albany group) thought another Bokononist term might be a good name: "Bokomaru ... the Bokononist ritual 'mingling of awareness,' consisting of placing the bare soles of one's feet in contact with those of another" (Jones 1973).

I think I like this even better. Both suggestions have the advantage of suggesting very attractive concepts. They may, however, be aesthetically undesirable to some, and will the Big Bad World take us seriously then, anyway? (Do we care?) If we end up being the ""East Coast Performing Arts Alliance" I won't kick. (Jones 1973)

Jones went on to suggest that the group "can and should build a repertoire of specific works which we can take here and there, supplemented with new pieces and experiments as the spirit moves us. 'Rainforest' is already in this category, from all indications" (Jones 1973). Other pieces suggested by Jones included *Stay On It* by Julius Eastman, *Players with Circuits* by David Behrman (performed at Chocorua '73 by Driscoll and Edelstein), and La Monte Young's *The Second Dream of The High-Tension Line Stepdown Transformer*. He also proposed creating a group drone piece, with "each preparing a sound or sound possibilities, and bringing them together, modifying as necessary, to present" (Jones 1973).

Jones, at SUNY Buffalo, was also working on organizing a performance of the large group *Rainforest* there, hoping for financial support from the Creative Associates. Even without a firm date for a *Rainforest* engagement, he insists in his letter that "We should begin work now on suitable objects and sound sources, so that we become well acquainted with our instruments. We need one or two large objects, like the cider barrel -- those willing to develop such objects, please do so, and let me know of your intent [...] Keep David and me informed of your progress,

and of any suggestions you might have, I in turn will tell you of mine" (Jones 1973) (the *Rainforest* Jones organized in Buffalo was presented the following year, on May 13 1974).

A one-page "Appendix A" to Jones' letter consists of two lists. "Pieces I can contribute as of 9/3/73" and "Pieces I plan to contribute in the future". The former names three original compositions including his Chocorua flute piece, *Saturday Afternoon / 5 O'Clock*, a 1972 piece for guitar, percussion and tape entitled "*Epitaph*"/*mobile for David*, and *Exposure Piece* ("no, you dirty people, it's not quite what you think"). The second list includes an untitled rhythm study involving three stereo tape decks, and an arrangement of "a medley of Frank Zappa tunes" (Jones 1973).

John Driscoll, writing from Silver Spring, Maryland, followed the dissemination of Jones' letter with an equally long and detailed response, beginning: "After receiving Petr Kotik's letter and Ralph Jones' I guess it is time to get busy" (Driscoll 1973). Driscoll describes a possible opportunity for the group to perform in the "swamp land near the capitol" with an alumni organisation of dancers from George Washington University, and discusses the possibility of obtaining some funding, but then notes that the issue of fundraising "entails the need for specific info. Such as what date, how many people, publicity, and most important how much money do you want, and how much you will do it for". The importance of naming the group then comes to the fore, and "my feelings are that the title should either describe the group or have absolutely nothing to do with it". Driscoll's two suggestions were "East Coast Collective" and "Multiplex".

Driscoll's shortlist of compositions which the group might make part of its repertoire included works by Emmet Williams, Dieter Rot, Christian Wolff, Toshi Ichiyanagi, Julius Eastman (*Wood In Time*, which had been performed at Chocorua by a quartet including Driscoll and Jones) and Takehisa Kosugi. "I feel we should make some decision", Driscoll wrote, "on whether the emphasis is on performing the group's work or being

inclusive of other peoples' work. I favor the use of both—the balance being determined by interest, availability of necessary materials, money and people to play or execute them. I'm not sure our offerings are any more bountiful than the rest of the world's" (Driscoll 1973).

Compositions of his own which Driscoll offered to the group included *Frogs* ("for one English speaking reader and one foreign speaking reader" plus electronics—it had been performed at Chocorua with Julius Eastman and Petr Kotik as readers), *a tour around cicero's bath* ("for magnetic tape and nine heat lamps [...] nine heaping platters of either white or spinach flavored spaghetti, and nine bluefish"), and *mahl stick / Brawley June 4 73*, for magnetic tape.

Driscoll's letter concludes with more rumination about the fate of New Music in New Hampshire, and enthusiasm for the future of the group: "I received a letter from Petr Kotik [...] In light of this letter I feel that some major decisions have to be made. [...] I find this idea of communicating with so many people at once fascinating, so keep in touch" (Driscoll 1973).

Over November 17 and 18 1973, some of the group met again in Albany at Julie Schwartz's home to continue discussions, and a name for the group was decided upon: "Pnumbral Raincoast". Phil Edelstein recalls:

I'm pretty sure we cooked up the Pnumbral Raincoast name at Julie's house—to a host of groans but it seemed to stick. The "rain" part was the homage to *Rainforest*. The "coast" part was a non-denominational combination of bunches of things, east-west, a feeling of an edge, waves. Pnumbral—had a bit of the ethereal, something that happens at a special time—some thing a little science-y, astronomical, a feminine moon-ish. A mangling of "penumbral"—possibly on purpose but as likely ignorance—can't say for sure. Think harvest moons—an autumn evening in upstate New York. We're finding this summer romance is going to last into a new season—and thoughts of activity for the coming year. (Edelstein 2005a)

Not only was a name decided upon, but the character of the group's mail network was modified. Martin Kalve, who was present at the meeting, took over the handling of communications and on November 19 instigated a new round-robin post format for disseminating information, which reduced workload on a single person. A form letter was sent to group members, beginning:

"On June 21, 1973, thirty-three musicians gathered..."
By July 11, 1973 most of the musicians had gone home, to join other groups, write/perform other music, meet new people, eat different food, experience new thrills, have different hassles, develop a new identity, see the world in a different climate, have new ideas, reconsider old ones--essentially, if we were to meet today, we would probably be amazed at what a different group of 33 musicians we have become.

If you are interested in receiving/sharing information from/with other people and are willing to use some of your time dealing with an organized system to do this, I have an idea which I think will enable you to do it with the least amount of hassle/most amount of benefit (Kalve 1973).

The proposed plan involved creating a "chain of information" based on an ordered list of contributors, in which one person would receive a single mailing from the person on the list before them, and after perusing the contents, and adding their own contributions, would mail it on to the next person on the list. When an item one person had contributed made a circuit and returned back to them, they would remove it: "you can remain anonymous by not putting your name on the info you send or vice/versa; be free" (Kalve 1973).

"The System," Kalve wrote, is open to

[...] info of any kind (notes, articles, scores, ideas, objects, books, etc) at any time you must mail on any info you receive within one week's time after receiving, Label all mailings on the outside:
Pnumbral Raincoast, when you receive some info that you put in

take it out, if there's anything in the system that hassles you change it". (Kalve 1973)

The instructions for joining in the mail network were simply to return a letter to Kalve indicating "yes" or "no". If "yes", the participant would be placed on the list and expected to help make the system work smoothly. Little archival evidence of the mail network, besides the initial letter announcing it, has been seen; not surprising perhaps, since the round-robin format would have meant greater ephemerality for its content.

John Driscoll recalls the formation of Pnumbral Raincoast as a group response to the substantial task of attempting to organise another event based on the 1973 New Music in New Hampshire project. After Petr Kotik's letter leaving the organisation of a 1974 gathering to others, "it sowed the seed of, well, gee, maybe this is bigger than what we want to bite off [...] So, I know there was discussion between, amongst us, and the idea came up of this Pnumbral Raincoast, trying to find out an umbrella we could operate under and would allow for us to take some performance aspects and carry it out. And I think that's really where Pnumbral Raincoast was the notion that doing another Chocorua would probably be too overwhelming for just about everybody" (Driscoll 2002).

Although short-lived, Pnumbral Raincoast acted as an umbrella for production of a number of concert and dance events through the end of 1975. The focus was on collaborative performance of pieces by members of the group: "We did individual pieces [...] It wasn't collective performance. I mean, we each performed in each other's, but it wasn't like we deliberately made collective pieces" (Driscoll 2002). In this sense, Pnumbral Raincoast followed the model of the Sonic Arts Union, founded by Mumma, Behrman, Lucier and Robert Ashley. Letterhead was created to give the group more impact in its communications with museums, galleries, universities, and other places where Pnumbral Raincoast sought engagements, and the group's press package eventually

contained impressive, identically formatted CVs for key members Schwartz, Driscoll, Edelstein, Kalve and a newcomer, percussionist Steve Bloom.

Driscoll says: "there were sort of spurs of *Rainforest* that started to emerge in parallel with Pnumbral Raincoast" (Driscoll 2002). Pnumbral included many of the people who had performed *Rainforest* at Chocorua '73, and plans by some of those same people to present the piece again were well underway at the time Pnumbral Raincoast was established. *Rainforest* was mentioned in press materials prepared for Pnumbral Raincoast publicity, and, as Ralph Jones says, "*Rainforest* was always the star around which we all orbited" (Jones 2001). Jones used the Pnumbral Raincoast Xerox mailing list to discuss in depth the logistics of the *Rainforest* performance he was organizing for May of 1974 in Buffalo (Jones 1973); the draft of a lengthy description of *Rainforest 4* was handwritten on Pnumbral letterhead; and Pnumbral was responsible for initiating the production of at least one performance of *Rainforest 4*, with David Tudor at Mills College in Oakland California, in April 1975. Pnumbral stationery was also used by John Driscoll for correspondence regarding organisation of a *Rainforest 4* presentation at York University in Toronto in 1975 (Driscoll 1975).

Pnumbral Raincoast, then, as a loose but committed organisation, paralleled, or perhaps "crossfaded", with the development of the *Rainforest 4* performing group which still had the core membership of John Driscoll, Phil Edelstein, Ralph Jones, Bill Viola, Linda Fisher, Martin Kalve, and of course, David Tudor. The first public presentation of *Rainforest 4* occurred in March 1974 at the Everson Museum in Syracuse NY; two other performances followed that year. In 1975 there were seven; in 1976, ten. Some of these engagements were multiple-day installations. Naming the *Rainforest* group did not become an issue until David Tudor was invited to bring *Rainforest 4* and a substantial program of other works to the 1976 Festival d'Automne in Paris, and it thus

required a more strongly defined identity: "Composers Inside Electronics". Chapter Six of this thesis looks at Composers Inside Electronics as a mentorship project of David Tudor: the group was his *Rainforest 4* performance ensemble as well as a cooperative group of independent artists who created a body of original works through which *Rainforest* resonated strongly.

Chapter 6

Composers Inside Electronics: Formalising the *Rainforest* community, 1974-1982

There's an aspect of it [the community of *Rainforest* performers] like, can I borrow a patch cord, can I borrow a cup of sugar. It's like, "I need a sound that will hold this thing up. Have you got such a thing?" And that was very functional. And there's a lot of giving and taking of things, coming from a rich social fabric of people who were inter-dependent in a very good way. On a certain level you couldn't do a solo *Rainforest*. It involved a community. You were given something that you had to really treasure.

Phil Edelstein
(Edelstein 2002)

It was certainly a highlight of my life to do this piece and it continues, even now, to reveal things about itself and David. And one thing I always think about David is that he was such a quiet person, in a way, didn't announce himself or advertise himself or his ideas or his theories. And, like any good teacher, was willing to plant a seed and not have to see the immediate result. Kind of knowing here's some fertile ground and throwing these seeds there and see what happens. And even this many years later, I have insights from that time. Which is a sign, I think, of a really deep work, a deep relationship—you know, that it can continue to reveal things.

Linda Fisher
(Fisher 2003)

The Rainforest group, 1974-1975

In 1986, Tudor made some interesting comments on the nature of teaching which are worth considering here, since they undoubtedly reflect his experiences with the Chocorua group as well as other occasional "students":

The relationship has to grow, between someone who's teaching and someone who wants to learn. I mean, there are cases where the best thing you can do is to send a student to someone else, you know, in order to learn something particular. That's what guidance is all about. And of course nowadays we can't, we can't behave like gurus. You know, that's very foolish, for us to do that.

[...]

I look for... a spark... that doesn't wish to do things in an academic background. That's what... I mean there are a lot of things that you look for in a student. Basically you just look for how you could help them. If there's no way you could help them, you try to be a good friend and give advice, whenever you're asked to do that.

(Tudor 1986)

A core of the Chocorua group clearly identified David Tudor as a mentor figure, if not "guru", and Tudor seems as clearly to have identified them as exceptional students whose energies brought new life into his piece. Their experience performing Tudor's *Rainforest* in its newest realisation, metamorphosing it from a relatively invisible, highly portable piece into a much more cumbersome but attractively sculptural work, had come about spontaneously and at least partly due to the participants' own youthful enthusiasm. Tudor had "given the piece away" (Tudor 1984) and received a great deal in return; immediately it seemed that *Rainforest* was due to have a new life well beyond the end of the New Music in New Hampshire workshop on July 11 1973, both in further presentations of the work itself, and also in new works which it inspired. Bill Viola wrote to David Tudor

that same month:

david -

just a short note to tell you how much I enjoyed the time spent in new hampshire. i'm still buzzing from all the new stuff that was shot into my head. i never really got the chance to tell you how much i appreciated things like the dinner you treated luf [Linda Fisher] & i to and how much the work we were doing really set me off and has given me a whole new set of problems to deal with. i've been really speedy and workin' like crazy since i've been back - it's great.

(Viola 1973)

Some of the *Rainforest* workshop participants left Chocorua equipped with the technology necessary to continue experimentation with loudspeaker-objects: Ralph Jones wrote with apologies to Tudor on July 17, less than a week after the end of the workshop:

Dear David

First things first I guess: you don't know how I hate to spring this on you, but as you can see, \$40.00 is not enclosed for Marty's [Martin Kalve] and my transducers. We both began new jobs today, and are essentially destitute until our first paychecks arrive.

(Jones 1973a)

Not only were Kalve and Jones captivated by the idea of the sounding object, they were also immediately committed to the idea of remounting the piece. Jones' letter continues:

The day after I returned, I went in search of a good space here [in Buffalo, NY] for *Rainforest*. I stopped by the old Post Office building downtown (soon to be vacated)... it is rather impressive from the outside, but...

(Jones 1973a)

Bill Viola also wrote to Tudor at the end of July, full of enthusiasm and hoping for hardware to continue working on *Rainforest*:

I still would like a transducer so reserve one if it's not too late. i'll get some money together this week and send it off to you.

(Viola 1973)

Involvement with *Rainforest* seemed to have given all its participants "a whole new set of problems to deal with" (Viola 1973): over the years to come, many would create works of their own which strongly reflected the premise behind *Rainforest*, and employ similar methods in their realisation. Some of these works will be considered later in this chapter.

Initial *Rainforest* outings

The first presentations of *Rainforest* following Chocorua were on a much smaller scale, both in numbers of personnel and objects, than the piece's debut in the New Hampshire barn. Bill Viola, who was then living in Syracuse NY, and working at the Everson Museum as assistant to museum curator David Ross, was instrumental in arranging a performance of *Rainforest* there on March 8 1974 (Fisher 2003). Four musicians participated (Viola, Fisher, Driscoll and Tudor) and a newspaper review of the event mentioned only six objects: "jointed aluminum stove pipe, the rim of a bicycle wheel, an old, rusty iron hoop about four feet in diameter, two copper toilet floats, a 50-gallon oil drum, painted white, and a blue plastic ring [...] Some listeners thought they heard the sound of crickets, some the moaning of a large animal in pain or fear, some the sound of the wind, and some weren't sure what they heard" (Miller 1974). The evening was co-presented by the museum and Syracuse's New Music Ensemble, and wine and cheese were served during the last hour of the performance (Everson Museum 1974).

Tudor was quoted on the occasion as saying that the elements of the piece included the "natural sound" of the objects as well as the "electronic transformation" of sound, with possible transformations including feeding

an object's signal back into itself until a strong resonance occurred, as well as the ability to feed the output of one object into another (Miller 1974). Linda Fisher says the Everson *Rainforest* "was pretty funky sounding [...] it had the qualities that we associate [with the piece], but it definitely was the first time that we were out of the gate and you could hear that sort of awkwardness and not really quite sure what we were doing yet" (Fisher 2003).

The performance was followed the next day by a less formal presentation by the same four musicians, with the goal of documenting the piece. This took place at Synapse, a student and community video center connected with Syracuse University of which Bill Viola was an original member. The version of *Rainforest* performed at Synapse differed from the previous day's in that the loudspeaker-objects were not amplified with contact microphones, but instead were heard as strictly acoustic objects, with conventional microphones employed for the purposes of recording them (Fisher 2003).

Since the new version of *Rainforest* was scalable, the issue of who might be invited to perform on any given occasion depended on resources, geography, and availability of personnel. David Tudor, with John Driscoll, made decisions about who to ask based in part on the question "what groupings would be the most productive?" (Driscoll 2001a). Ralph Jones says that "some of us who were pretty central to the group were absent for a lot of performances. I was absent for a lot of performances. It depended on a lot of different contingencies—who was available, what the budget was like, does it permit for travel and shipping and things like that. So it was very much a fluid group" (Jones 2000). Jones was not present for the two Syracuse performances in March 1974 but was busy organizing the next *Rainforest*, which was held on June 12 of that year at Buffalo State College, as a production of the Creative Associates (logistics of the upcoming performance were discussed in detail in the round-robin Pnumbral Raincoast mailing list as described in the previous chapter) (Jones 1973a).

Phil Edelstein recalls, "I can't figure out why I didn't go to Syracuse [for the Everson performance] — probably because I wasn't asked [...] or was it because they were looking for people geographically close?" (Edelstein 2002). David Tudor was part of nearly every performance—of the 28 *Rainforest* installations between 1973 and 1982, he missed only two. John Driscoll, identified by many members of the group as perhaps its primary organiser, similarly only missed two. The number of performers fluctuated widely, occasionally a minimal two (Driscoll and Tudor presented one 1975 *Rainforest* as a duo, as did Driscoll and Edelstein in 1981) but more usually numbering between four and seven. Often, performers local to the venue would be enlisted. Some of these were professional performers, usually friends of Tudor and the core group.

Student performers were also often welcomed, however, since many *Rainforests* were presented in college and university settings. Local instructors recognized the pedagogical value of the piece as it involved aspects of acoustics, electronic music, field recording, visual presentation, and ensemble performance practice, and three of the seven 1975 performances involved workshops with students: York University in Toronto, Mills College in Oakland, California and the Fort Worth Art Museum in Fort Worth, Texas. Paul DeMarinis, then a recent MFA graduate of Mills College, joined in the *Rainforest* at Mills in April 1975 and became an important member of the core group.

It should be noted that the large-scale group version of *Rainforest*, which on its first presentation at Chocorua had been given the long, site-specific title, *Sliding Pitches in the Rainforest in the Field*, for many years afterward remained titled simply *Rainforest* in programme books, advertising, and correspondence both official and between members of the group. The designation *Rainforest 4* (or, as it is often written, *Rainforest IV*) was not applied until the LP recording of the piece was



Figure 6-1. *Rainforest* installation at Buffalo State College, Buffalo NY, June 12 1974. Top: overview of the room, with John Driscoll at his table. Bottom: David Tudor. Photographer unknown, UBDigit Digital Collections, Music Library, State University of New York at Buffalo.

released in 1981. Tudor's decision that this new version of *Rainforest* represented the fourth stage in the evolution of the piece was made much earlier, however. Programmes from performances as early as February 1976 include a standardised note about the history of the piece explaining its origin as a commission for Merce Cunningham's dance 1968 *RainForest*, while "The present version (the fourth) mixes the live sound in space of the suspended physical objects, with their transformed reflections in an audio system" (Crane School of Music 1976).

Although the piece remained simply *Rainforest*, that title was often augmented by a subtitle which varied from time to time, serving to differentiate this version from the previous small-scale *Rainforests*. Between 1976 and 1979, the piece was variously referred to as "an electronic environmental concert", "an electro-acoustical environment", "a collaborative electro-acoustical environment", and "an electronic ecology" (the latter apparently coined by a Los Angeles newspaper reviewer writing about the *Rainforest 4* presented at the Los Angeles County Museum in 1976) (Tudor 1976a).

Dynamics of the evolving group

The two initial presentations in Syracuse in March 1974 gave the group substantial energy for continuing to seek further *Rainforest* engagements, and also fed into the musicians' independent creative work. Following the Syracuse events, Viola wrote immediately to Tudor:

luf [Linda Fisher] and i were "buzzing" all the way down the thruway after that weekend. i think we all felt it - the piece is just getting more intense every time. and again i got so charged up with energy and new ideas from doing the piece and seeing everyone, i didn't know what to do first when i returned. the neatest thing about it is that the entire weekend was rainforest - the sounds started as soon as we got everything hung and continued until the last power switch was cut off - going long before and after the "public" had come and gone. and the feeling was carried over into the traditional rainforest dinner and late night drinking. if things continue this way, next year

and beyond could be truly amazing. (boy that's nice to look forward to)

i think i told you this before but it always comes up, being involved with this piece and meeting you has redefined a lot of things for me. (i don't want to sound corny but it's true.) you've completely changed my concept of sound, for one. that's something that's even carried into my video work. i've never been able to grasp the notion of sound as a substance before. anyway, all i can say is i can't wait till the next rainforest!

[...]

harithas [James Harithas, formerly Director of the Everson and at that time recently appointed as new Director of the Contemporary Arts Museum in Houston, TX] spoke with me about doing a rainforest in houston when he gets settled there in the fall... i am also going to write to jane livingstone [Curator] at the l.a. county museum to see the possibilities there...

[...]

i'm working on a bunch of new pieces - sound installations mostly - involving recordings with moving mics and a large scale piece i got the idea for by listening to the sound of a steam pile driver bounce sound waves off buildings in downtown syracuse. i was captivated for hours. i am going to use microphones in a situation like that to feed the spatially delayed sound back into source.

(Viola 1974a)

This communication illuminates the significant effects that Tudor and *Rainforest* were having on Viola's work, and the symbiotic relationship which the younger artist had already formed with the older. The quoted portion above is an indication of how seriously Viola was pursuing more exposure for *Rainforest*, based on his recent connections with influential curators, while the letter concludes with Viola requesting "those addresses you said you had" in Köln, Germany as he was soon heading to an art fair in that city—an illustration of the practical support Tudor could offer as a senior, well-travelled artist with a broad network of contacts (Viola 1974a). Also interesting in the letter are the references, even at this early stage, to "traditions" associated with the new large group version of *Rainforest*—semi-ritualistic activities revolving for the

most part around food and drink. This aspect of life with *Rainforest* will be examined later in the chapter, but it is worth noting here Linda Fisher's mention of a "kind of ritual of ablutions" first enacted at the Everson Museum, to begin the first public performance of *Rainforest*:

These little sips of alcohol that we would have as we began the performance [...] David would come over in his very paternal way and we'd hold our little cup out—and we all got to the point where we carried one of these little cups—and he'd fill it and the piece would begin. And so, there was that ritual affect. It wasn't so much oh, I'm going to get tipsy or I'm going to get drunk, but almost a communion, I felt. [...] I remember clearly from [the Everson performance] and from many times following that. (Fisher 2003)

Viola continued to act as an advocate for *Rainforest* after he relocated from Syracuse to Florence, Italy in September 1974, where he took on the role of technical director at the video facility Art/Tapes/22; in a letter written late that year, he enthused:

I've been in Florence since September - that's too long [to have gone without seeing Tudor]. But you are constantly on my mind there - that's a kind of communication in itself. and the thoughts/images of you and rainforest and everything else do not fade with the passage of time - they get reinforced and grow stronger. i hope that it won't be too long before we can do another performance. i heard from ralph jones that the jan 26 washington one will not be happening. - quite depressing - i was kind of living for that for awhile - i really could use a charge in the old "batteries" these days.

[...]

i was talking with ralph about rainforest (naturally) - boy, it has left its mark on everyone it touches. we both agreed that there is something really special in that piece - more than just a performance of electronic music - and it's really important that the piece gets performed - and people in many places get the chance to share that experience. i hope this spring somewhere there is something lined up - i'm working on italy/europe.

(Viola 1974b)

Linda Fisher, about the same time, was still performing with Mother Mallard's Portable Masterpiece Company, and visiting David Tudor

regularly: "I used to go down to Stony Point a lot. I could get there on two dollars' worth of gas in my VW [...] and so I would go to Stony Point for the weekend and hang out" (Fisher 2003). In late 1974, she created what was probably the first work of any among the group which might be described as a *Rainforest* homage: a piece for live performance with dance, involving loudspeaker-objects. She wrote to Tudor:

the piece with resonating objects went exquisitely [...] for program's sake, it was called "hill of birds" and used material from a recording I did of some mockingbirds and wood frogs. Needless to say, next to the great volume and sensationalism of Mother Mallard it was so delicate and unhurried and most people never noticed it or cared and it fit beautifully with the choreography. (Fisher 1974b)

Her pleasure in creating new work using techniques from *Rainforest* turned to self-critical dissatisfaction in 1975, however, expressed in a letter to Tudor following performances accompanying Merce Cunningham *Events*:

During the Merce *Events* I was at peaks of self-distrust so I didn't have courage to do a work of my own, and risk fucking up, so I did the safest thing, something of yours, basically. This left me quite empty and bored with myself - (not your work but my fear)

now I'm gathering a new group of objects, and exploring different ways to have source material - please try to let me know immediately if you expect me at the LA Rainforest Performance [Los Angeles County Museum, November 1975] and give me details if so...

(Fisher 1975a)

Metaphors for the group, and John Driscoll's role

At this time, the Gate Hill co-operative community where Tudor lived, near Stony Point NY, had also been home to John Cage for several years, and Cunningham Company musician David Behrman was then also a current resident. John Driscoll soon relocated from Washington DC

to another house in the co-op, where he worked closely with Tudor on the organisation behind presentations of *Rainforest*.

John Driscoll is frequently identified by other members of the group as perhaps the most important driving force behind the continued presentation of *Rainforest*, partly because he frequently took charge of the details of its presentation on a practical level: Bill Viola has said that if organisation had not been taken on by Driscoll, but instead been left to David Tudor, "nothing would have happened" (Viola 2001a). Driscoll's continuous organisational work, as a sort of right-hand man to Tudor, eventually became a point of concern with him and was expressed, after Tudor's death in 1996, as frustration with having continually been the "point person" for the group, seemingly always smoothing the way for everybody else to arrive and do their work. In the context of a dinner in 2001 which included other members of Composers Inside Electronics, he explained this time-consuming and often underappreciated role as having been undertaken "out of dedication" to Tudor (Driscoll 2001a).

Linda Fisher compared the group to a family of siblings:

It was like John Driscoll is the big brother, Phil Edelstein is the little brother that wants to be sort of like the big brother and sort of tags around and Bill and I are like the twins over here, you know, that people leave alone. It was just...it was funny, it was like a family and we would get together to set up in a space and it would always be the same kind of little drama would play out. I shouldn't say this, but where John and Phil and David would be the ones deciding, it was mostly John. David would kind of go along with it. I think David liked it that there were people willing to kind of take over because then he could kind of withdraw and putter at his table and not really have to make the big decisions or be an organizer, but he could step in if he felt that it was important. So John was often the one that kind of coordinated all the practical aspects of a performance and, you know, there was always the decision when you got to the space where your table was going to be and where your objects were going to hang and which speaker you got to use and there would always be maybe eight speakers or four speakers and there would always be two that were better and two that were not quite as good. And so, who's going to get which one and it was funny that way. It became kind of a family joke. You know, that process of deciding

who would sit where and which speakers we'd get to use and all that kind of thing. (Fisher 2003)

Bill Viola chose to describe the makeup of the group as an exposition of Tudor's own complex personality, also identifying Driscoll as occupying a position of central importance:

Driscoll, I love him dearly, he's a dear friend. He was really very precise and technical, and David gathered around him people who reflected him. I was kind of a funny guy, I kidded around, and I had a kind of poetic side to me. Phil Edelstein was this kind of computer guy, with the latest technology, Driscoll was very organized, he used to make the travel arrangements, everything was clear with John. And they were all David. [...] Linda was the female side, very sensitive. I connected with her very strongly. (Viola 2000)

Paul DeMarinis goes so far as to state that, beyond being essential to the organisation of continued performances, John Driscoll was "actually the author of *Rainforest 4*. I think his authorship is very strong, the kinds of sounds, the kinds of objects [...] sculpturally, it largely is. His visual aesthetic, his sense of sculpture" (DeMarinis, 2001). Certainly some of the more extravagant, less prosaic "compound objects" (for instance, the toilet float assemblages) which have been prominent in the piece originated with Driscoll.

John Driscoll also used the metaphor of the family to describe the core group of *Rainforesters*, in explaining his role as organiser:

I was saying to Nancy [Perloff, curator at the Getty Research Institute], the thing you have to remember with *Rainforest* is that it wasn't so much just about the piece but almost a family of people, and after awhile that became as important. Because she was asking well how did you pick who did what [...] and I said well that was always a tricky issue. Because David and I were living in the same location at that point it was just natural that we would plan them. [...] So what started to happen was there was a core group that we would start to do this with, you know, Phil, Martin, and myself, Linda Fisher, and Bill Viola. And then it would depend on what we were doing, whether there was enough budget for how

many people. Then slowly over time as it went on we would try to draw new people into it, so there was a mix but there was a core group that we would try to keep and then it would depend on budget and availability. (Driscoll 2000b)

The issue of authorship aside, John Driscoll's imprint is clearly strong in the development and continuation of *Rainforest* and the evolution of the group which performed it. This extended to the formal naming of the group in 1976, when "Composers Inside Electronics" was created, which is the focus of the next section of this chapter.

Momentarily, though, it would be interesting to pause in 1975 and consider changes which had come about in the sound of *Rainforest 4* over the two years since its 1973 workshop presentation in the barn in New Hampshire. Critic Tom Johnson wrote a detailed description of that first performance, which is quoted in the previous chapter. Johnson revisited *Rainforest* in 1975, attending an installation at The Kitchen, an artist-run performance and exhibition space in New York City, and remarked in a column in the magazine *High Fidelity*:

The installation has grown quite a lot. A few objects, such as the bed springs, have been abandoned, but many new ones have been added, including a few which appear to have been specially designed for the piece. The sound was much denser than it had been in New Hampshire. Walking across the space did seem a bit like walking through a rainforest, with a dense undergrowth of different sounds coming from all directions. Much of the music was rhythmic, proceeding in pulses or bleeps of one sort or another, but the patterns were constantly changing and the colors were much richer than in the case of pure electronic sounds generated directly from manufactured synthesizers. [...] Its dense textures of sound are ravishing. It is one of the few forms of casual audience-participation music which really works, without making anyone uncomfortable and without sacrificing musical values. (Johnson 1975)

The change Johnson perceived in the character of the piece, leaning towards a more naturalistic, rainforest-like soundscape (even if the

rainforest in question was a purely imaginary one) populated by a greater diversity of sonic "undergrowth", identifies a trajectory which I argue could be said to be true of *Rainforest* since its first version in 1968.

Rainforest: group dynamics and organisation

David Tudor, by the end of 1975, had a fairly strong group working with him already, albeit an ad hoc ensemble that went nameless: the players were always named individually on concert programmes, under the heading of "*Rainforest* by David Tudor". This was clearly not seen as a problem; unlike the case of the related group Pnumbral Raincoast, for which a name was seen as centrally important, engendering long letters and conversations over the matter, Tudor's *Rainforest* group seems to have spent little or no energy considering how to define themselves in this way.

By August 1976, *Rainforest* had been produced fifteen times: at the Everson Museum and Synapse in Syracuse, Buffalo State College, the Free Music Store in Albany NY, York University in Toronto Canada, Mills College in Oakland CA; The Kitchen in New York City; the Fort Worth Art Museum, Fort Worth TX; the de Saisset Museum at Santa Clara University, CA; the Los Angeles County Museum, CA; the State University of New York at Potsdam, NY; Cobleskil State College, Cobleskil, NY; the Contemporary Art Museum, Houston TX; the Walker Art Museum, Minneapolis MN; and the University of Northern Illinois, DeKalb, IL (see Appendix for a full listing of *Rainforest 4* presentations).

These were all single-day affairs, involving one performance and occasionally a workshop, with the exception of the Walker Art Museum, which involved five performances over five days, between June 12 and 16 1976. Engagements after this point in time tended not to be "one-night stands" but more often than not were multiple-day installations, with numerous performances; certainly the preliminary work and expense

involved in transporting objects and other equipment, and the efforts needed to install the piece properly would have suggested that longer runs would better serve both the presenting organisation and the performing artists.

The 1976 Walker engagement is interesting to look at in slightly more detail, because the Museum's archives document some of the background to the presentation of *Rainforest*, throwing more light on the processes by which the piece was produced. First of all, organisational communications with the Walker came directly from Tudor, although with John Driscoll's role as de facto right-hand man quite apparent. Initial contact with Suzanne Weil, the Walker's Coordinator of Performing Arts, seems to have been made by Tudor via telephone in the fall of 1975, attempting to set up a *Rainforest* in November of that year. Tudor had an existing personal connection with Weil—in October 1974 he accompanied the Viola Farber Dance Company during their residency at the Walker—so the tone of their correspondence following his telephone call is friendly, even fond. Tudor immediately sent a package of *Rainforest* press, promotional and biographical materials, this time suggesting possible dates in November 1976, with the comment that "A few days in advance are needed to find and assemble some larger objects locally—this is lots of fun if we are not under pressure". Additionally, Tudor added that "it's possible to think of an outdoor space, the museum roof perhaps—although hanging there might be very difficult and the weather has to be pleasant" (Tudor 1975).

In April 1976, two months before the event, Tudor wrote to Weil, "The other performers will be: John Driscoll, Philip Edelstein, William Viola. You may know Bill already through his video work. John is sending you, independently, colour slides which we thought best, as our only good

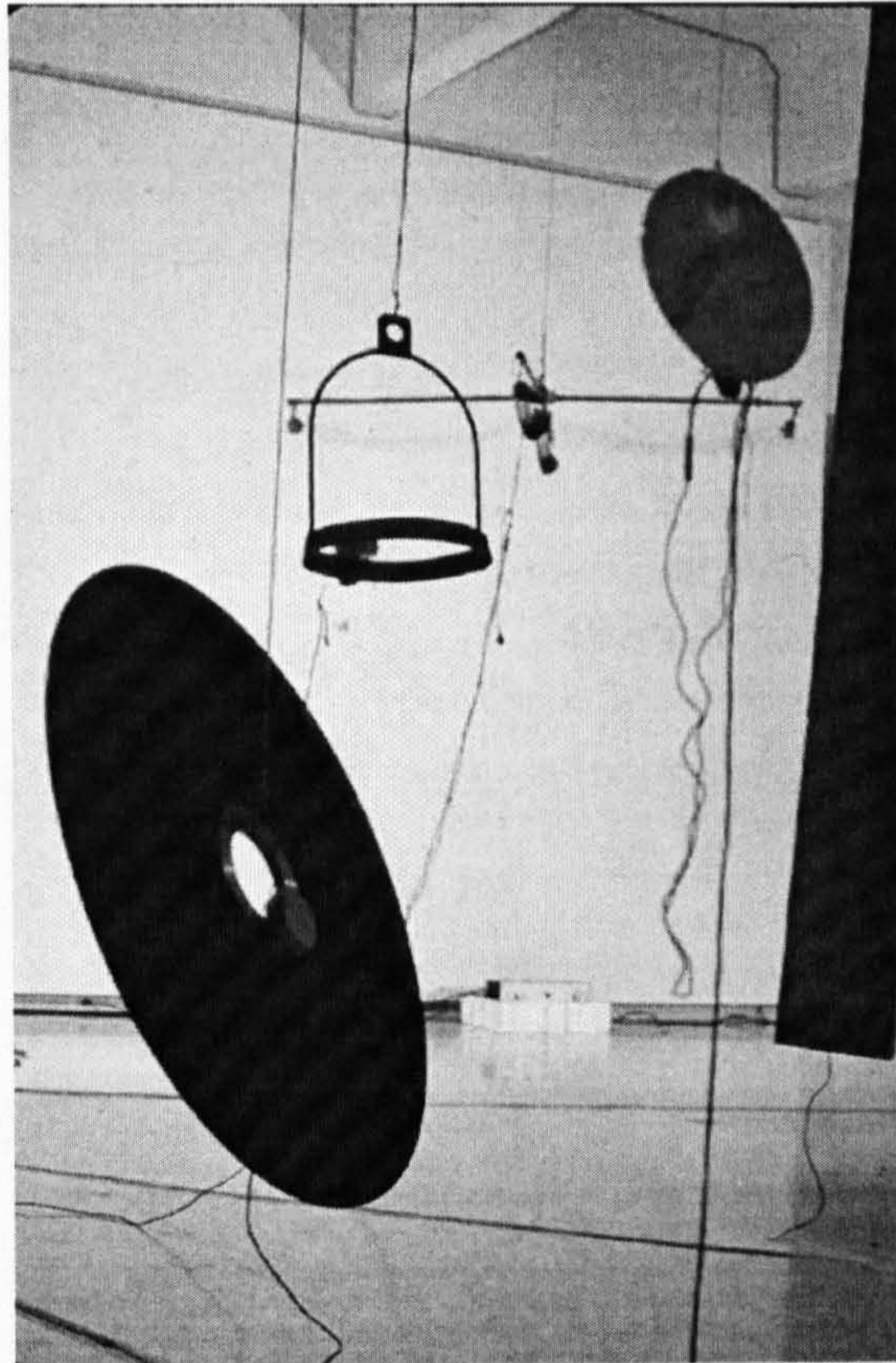
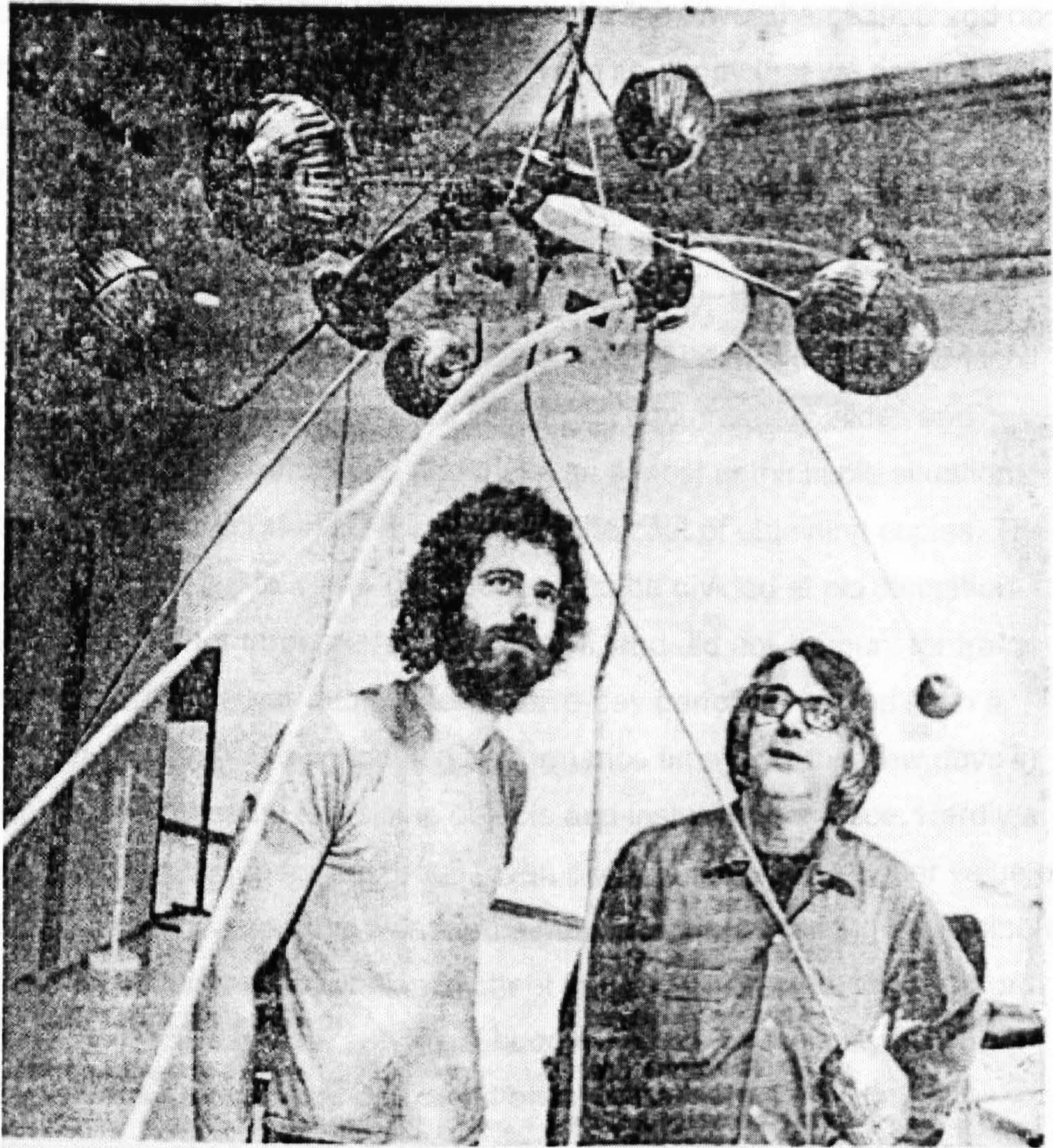

Figure 6-2. Walker Art Centre *Rainforest 4* installation, June 1976. Large hard drive (foreground), "bird cage", Slinky compound object, metal disk. Photograph by John Driscoll.



Figure 6-3. Walker Art Centre *Rainforest 4* installation, June 1976. Unidentified individuals experiencing oil drum. Photograph by John Driscoll.

pieces are black and white and have been sent to Santa Cruz. We desperately need to have the slides sent back as soon as you can return them—they are originals and just now we are working with them trying to get together good photographic material" (Tudor 1976a). Well responded



Star Photo by William Seaman

COMPOSER-MUSICIAN DAVID TUDOR (RIGHT) AND JOHN DRISCOLL

Toilet tank floats are part of a bizarre sound-producing device

Figure 6-4. Photograph of John Driscoll and David Tudor at the Walker Art Centre installation of *Rainforest 4*, June 1976 (from Close 1976).

photos are black and white and have been sent to Santa Clara. We desperately need to have the slides sent back as soon as you can return them—they are originals and just now we are working with them trying to get together good photographic material" (Tudor 1976a). Weil responded confirming budget—Tudor's artist fee to be "no lower than \$3000 and no higher than \$3500"—and concluded "I am so happy that we are finally able to have you back and to experience RAINFOREST—it's about time" (Weil 1976).

All these details suggest much about the sketchy, shoestring nature of *Rainforest* management and production to that point. Tudor and Driscoll had sent out their only copies of *Rainforest* documentary slides and photographs as promotional materials, an almost unthinkable situation, but perhaps understandable in terms of the cost of obtaining copies. The Walker's total fee to Tudor of \$3500 was to be divided at his discretion among the other three performers as well, and did not account for travel expenses, lodging or meals over the five-day performance run (with a total of sixteen hours scheduled performance time), nor the "few days in advance" necessary for finding objects and installing the piece. Hardly a windfall paycheque for the group, even given the relatively higher value of the 1976 dollar—and this was from a major institution inviting a prominent artist. In all fairness, the balance sheet for the Walker's presentation of *Rainforest* shows some additional budget spent on hospitality (about \$150 for two dinners), and Weil did offer to provide accomodation, presumably at her home: "I can provide beds if you have transportation (will bill house and somewhat feed, but I won't schlepp)" (Weil 1976). This, however, raises the issue that not only were the *Rainforesters* expected to be performing artists, they were also the roadies for the "extravaganza" (Weil 1976), and were responsible for most of the "schlepping" and installation of equipment and objects, presumably with the assistance of students or technical staff connected with the gallery.

Russell Frehling, speaking about his first *Rainforest* experience two years later (at the University of North Carolina in March 1978), reflected on this aspect of continually "making do", and the necessity for self-reliance, in the culture of producing the piece:

The money wasn't that great, and to load up the van and move... you know, when I got to see how *Rainforest* traveled and the work it took, that was an eye-opener. And the lack of support on the ground [...] just shocked me. It showed how little respect was afforded David for what I considered a major artistic effort. [...] Here was what I considered the greatest artist alive, shuffling from place to place in a van, in stinking hotel rooms, not getting paid nearly enough, doing all this stuff that other people would have assistants to do. Not even the places that invite him to come take care of business to make it the best it can be. And of course, David... I mean, he was a good sport in a lot of ways. He didn't bitch. He took care of business first, but you could tell, man, after a show he wasn't a happy camper in that way. [...] And it was just very depressing for me to see. [...] if I can grow up and be half the artist that he is, that's as much as I dare expect, and yet what do you get in return for that? I mean, he's given up his life here, literally, for people that don't give a shit. And it was very tough on me. And again, I'm seeing it through the eyes of a 19 or 20 year old who's still got this kind of, you know, hero worship kind of thing going on and I don't think my sense of reality was all that mature at that point. But that was the thing—sort of getting that ideal shattered. And it was a distraction from that amazing artistic experience of working with him and with Marty [Martin Kalve] and Phil [Edelstein] too. I mean, these guys had spent a lot of time with David, knew a lot of stuff, had sort of learned that style of... that working method of... they knew how to use tools, they knew how to take care of business and be totally self-reliant, they knew the intricacies of *Rainforest* inside and out. These guys were extremely well-prepared. (Frehling 2002)

The problem of performers-as-agents, and performers-as-roadies, is, of course, that it eventually becomes difficult for the performers to sustain the energies required to produce the work. John Driscoll says, of the main reason for the long hiatus which the group entered into from 1983 until Tudor's death in 1996, "we were probably running out of steam on all fronts" (Driscoll 2002).

From 1976 onwards, however, the group did receive substantial behind-the-scenes assistance with its most ambitious projects—particularly productions of *Rainforest 4* in Europe—from Performing Artservices, the New York arts management company founded in New York by Mimi Johnson in 1972, which had as one of its first projects the organisation behind John Cage and David Tudor's 1972 summer tour featuring *Mureau* with *Rainforest 3* (as detailed in Chapter 4). In 1976, Artservices became involved with *Rainforest 4* for the first time, following an invitation extended to David Tudor, via the organisation (Johnson 2005), to develop a program of concerts for that year's Festival d'Automne in Paris. *Rainforest* was clearly on the agenda, but Tudor thought to involve *Rainforest's* performers as creative artists in their own right; beside their commitment to Tudor and *Rainforest*, all were composers/performers/artists with their own active solo careers. They had in common an interest in the use of new technologies, devices based on home-built circuits, and a dedication to an "experimental" aesthetic in performance which might be best expressed as a willingness to accept (or a desire to invite) the unexpected.

If the group was to participate in a major festival, presenting a broad selection of other work in addition to *Rainforest*, Tudor felt that it should have a formal identity, and so the members' commonality of interest in "home-made" technology (although it will be seen that not all members were equally interested) came to define its name.

Composers Inside Electronics: named of necessity

I think it was probably John and David, maybe Phil, but it was a way of organizing and I thought of it originally as a construct for the Festival d'Automne gig, to make some kind of a credible sounding blanket. Basically, they wanted David, and David wanted to do other stuff. He wanted to do stuff that was more interesting to him. (DeMarinis 2001)

I would guess that it was John and David [who named the group] on a cooking fest in Stony Point. I can't remember that I was there, but I can easily believe that it was either that Mimi [Johnson] said "we need to figure out how to present this thing to pitch to Paris", it was either done at Artservices or David's kitchen in Stony Point—it must have been in one of those two places. (Edelstein 2002)

John and Phil [came up with the name] I think. It sounds like something they would come up with... [or] John would come up with. (Fisher 2003)

It's a very good name. I wasn't really involved. I think it pretty much came from David. [...] At the Festival d'Automne, as a part of the preparations for that. And I may have taken a phone call about it, or something like that, but I was very peripherally involved. (Jones 2001)

Tudor's invitation to the 1976 Festival d'Automne culminated in a one-week residency, between October 20 and 26 at the Musée Galliera, for the newly minted Composers Inside Electronics: David Tudor, plus six core members of the *Rainforest* group who had attended his workshop in 1973 (Driscoll, Edelstein, Fisher, Jones, Kalve, Viola), with the addition of Paul DeMarinis who had performed in the piece at Mills College the previous year.

Rainforest was presented only on the first day, as a four-hour performance (although it received a four-day coda performance at a second venue, l'Éspace Pierre Cardin, outside the Festival's programming). The balance of the Musée Galliera residency involved two concerts which saw the members of CIE present a large number of original works, another two featuring an equally large number of works by composers from outside the group, and a fifth concert of Tudor works

which were not *Rainforest*. The exercise was taxing for CIE: Paul DeMarinis says that the series

[...] was supposed to be an installation of *Rainforest* and a series of concerts by composers of electronics, inside of which David Tudor definitely was a senior member. But they [the Festival organisers] wanted David to play a bunch of Cage works, and so with very little preparation we were supposed to do part of *Atlas Eclipticalis* [...] we did an Ichiyanagi piece, we did *Cartridge Music*, which was a lot of fun. David did a [Richard] Maxfield tiddlywinks piece [*Piano Concert for David Tudor*], a very memorable performance of that [...]" (DeMarinis 2001)

In addition, several installation works by DeMarinis and Jones were included, which ran for the duration of the week (see Figure 6-5).

<p>Musée Galliera 20 au 26 octobre à 20 h 30 relâche le dimanche 24</p> <p>COMPOSERS INSIDE ELECTRONICS réalisation : DAVID TUDOR avec la collaboration de John Driscoll, Philip Edelstein, Linda Fisher, Ralph Jones, Martin Kalve, Paul de Marinis, William Viola</p> <p>• 20 octobre : DAVID TUDOR « rainforest » 1973 an electronic ecology (durée : 4 heures) *</p> <p>• 21 octobre : RICHARD MAXFIELD « Piano Concert for David Tudor » 1961 par David Tudor TOSHI ICHIYANAGI « Sapporo » 1962 * JOHN CAGE « Cartridge Music » 1958 (version théâtre) *</p> <p>• 22 octobre : PAUL DE MARINIS « Molimo » 1976 par Martin Kalve et Paul de Marinis WILLIAM VIOLA « Gong » 1976 par Linda Fischer et William Viola JOHN DRISCOLL ET PHILIP EDELSTEIN « Interfeed » 1975 par Philip Edelstein et John Driscoll.</p> <p>• 23 octobre : DAVID TUDOR « Microphone » 1973 par David Tudor et Linda Fisher « Pulsers » 1976 par David Tudor</p>	<p>• 25 octobre : JOHN DRISCOLL « Listening Out Loud » 1975 par Paul de Marinis, John Driscoll et William Viola. PHILIP EDELSTEIN « Zabriskle Point » 1976, par P. Edelstein</p> <p>MARTIN KALVE « Et puis... et puis... est-ce que je puis » 1973 (avec la participation du public)</p> <p>• 26 octobre : TAKEHISA KOSUGI « Catch Wave » 1965 * JOHN CAGE « Atlas Eclipticalis » 1961-62 * (version percussion)</p> <p>les œuvres marquées d'une astérisque * seront présentées par : J. Driscoll, P. Edelstein, L. Fisher, R. Jones, M. Kalve, P. de Marinis, D. Tudor, W. Viola.</p> <p>Installations permanentes au Musée Galliera 20 au 26 octobre RALPH JONES « Circuitree » 1974 PAUL DE MARINIS « Pygmy Gamelañ » 1973 RALPH JONES « Sources of Naturally-occurring Ultrasonics » 1976</p>
--	---

Figure 6-5. Detail from Festival d'Automne programme book for series presented by David Tudor and Composers Inside Electronics, Paris 1976 (CIE 1976b).

Once again, external circumstances seem to have driven new developments in Tudor's career: although some members of the *Rainforest* group had joined together for performances pre-1976 (Driscoll and Edelstein had performed as a duo in 1975, for instance), those occasions were not identified as connected in any way with the larger group. The identity of the group was until 1976 bound up with one piece, *Rainforest*, in a focused manner, which could be contrasted with Pnumbral Raincoast, which was imagined from the start as a performance ensemble which would act as a collective to play works by members of the group, but which would also develop a repertoire of concert pieces by other well-known composers. The invitation from the Festival d'Automne brought Tudor an opportunity "to do stuff that was more interesting to him" (DeMarinis 2001). It suggested a reformulation of the *Rainforest* group's identity, and his relationship to it: in putting forward the program he developed for CIE in Paris, he took on the role of mentor. Members of CIE have commented on his decision to highlight their work on the Paris programme as a generosity extended from a well-known figure to his relatively unknown protégés. John Driscoll remarks that "he was willing to, you know, risk his reputation to a certain degree to present ours" (Driscoll 2002). The inclusion of the "classic" experimental works by Cage and others, however, suggests that not only did Tudor wish to satisfy the apparent desire of the programmers to involve him in his historical role as an interpreter of indeterminate compositions; in bringing those pieces to CIE he was perhaps also being deliberately instructive in the history of those works, and the performance practice associated with them.

The name Composers Inside Electronics was decided upon by Driscoll and Tudor, without much, if any, consultation with the *Rainforest* group. Driscoll says,

The name evolved from discussions between David and me, and reflected David's fascination with how electronic components take on their own personalities and suggest musical directions derived

from intense experimentation with them—thus, *Composers Inside Electronics*. (Driscoll and Rogalsky, 2004)

The imposition of the name—it was "announced to the group", according to Bill Viola (Viola 2001b)—seems to have been quite acceptable to the other group members, who may have felt, like Ralph Jones, that "It's a very good name" (Jones 2001) which reflected the relationship each of them felt they had, in their own way, with the technologies employed in their work. Not all were experimenters and builders of the electronic hobbyist variety; Linda Fisher, in particular, later expressed that the technological was "my weakness" (Fisher 1980) and that she "wasn't thinking in terms of large-scale constructions or innovative circuitry" (Fisher 1979). She has also said that the group's name did not resonate particularly well with her (Fisher 2003). But on her own terms, she was also excited by the technological: "last night was warm and the seven or eight ponds within hearing distance were full of noisy peepers - it makes me uncomfortable to think that they've begun singing - I wanted to do some recording of them but my SONY [cassette recorder] which I ordered isn't in yet" (Fisher 1975b). John Driscoll also recalled that Fisher brought some dramatic technological advances to the performance of *Rainforest*: "I remember at one point Linda had a four-track, and that sort of broke the ice because, I mean, man, she had all these singles [single tracks to address to multiple objects]" (Driscoll 2002).

Bill Viola, similarly to Fisher, also expressed an "ambivalence" toward circuit building in the early 1970s:

I was having a growing problem at the time I met [Tudor], with the abstraction of electronic sound, something that just troubled me about it, its disconnectedness from the human world. I remember really struggling to try to feel those electrons, sort of bouncing around the wires, that would help me understand what an oscillator was doing, you know it had to be some kind of physical thing. And then the fact that you could do anything, there's so much, with this sound. [... I] was bothered by the infinite possibilities—another circuit, another possibility. (Viola 2000)

Like Fisher, Viola was drawn to the use of portable hi-fi recording equipment, which he felt could capture a rich world of natural sounds that often outperformed the electronic (Tudor "turned me on to field recording [...] even your breathing had to be regulated not to disturb the mics, to just feel the sound, become the whole sound field". (Viola 2000)), and in a 1974 letter to Tudor enthused, like Fisher, about new gear acquired for this purpose:

i got some new instruments - the sony 1525D - (finally - superb!) with two ECM 220 condensers (i'm hooking up a binaural rig now) also a sony MX-14 six input mixer - a really nice unit... and i finally scrounged up enough for two JBL 4311 control monitor speakers - boy are they nice - i'm working on a bunch of new pieces—sound installations mostly—involving recordings with moving mics [...]
(Viola 1974a)

David Tudor explained the new designation Composers Inside Electronics, however, in terms of an anti-commercial aesthetic, a pride in "starting from nothing", and most importantly, a deep understanding of new technologies and their possibilities and limitations:

I tried to think of what we were doing, that other people don't do, and the thing is that we... first of all... that we built equipment but also that we think about what's inside. And is it doing what we would like it to do, or what it can do? Instead of using the components as givens, like university composers [laughter]. It's amazing... kids go to school and they get their hands on all that expensive equipment and they don't have the experience of starting from nothing. [...] We do our own stuff. We've had several series. It was just a means of really getting a group name. That's the only thing I could come up with on short notice that expressed my opposition to synthesizers, et cetera. [...] They're a good group and I especially like the fact that they all come from different disciplines.
(Tudor 1984)

Tudor's antipathy for mass-produced electronic instruments, as a "depersonalising" force in music, was further articulated in the following passage from the same interview, which also suggests that the means of subverting the sameness which commercial gear threatens to impart lies

in getting "inside" the electronics so well—so fully understanding its workings—that its unimagined sonic possibilities may be discovered and exploited:

I hated the way those machines were so predictable and it's very difficult to make them sound, you know, different than they're suppose to. So, my first few runs using a synthesizer, I just accumulated all my gain stages and [...] tried to freak the thing out. It worked very well. [...] I use the synthesizer in performance for one piece or another, I mean, for instance John Cage's *Variations VI*. We had that and *Variations VII*. [...] the only thing available was this synthesizer. So I put all my gain stages into a single oscillator [laughing] and the poor thing doesn't know what it's doing. It turned out to be fun, eventually. (Tudor 1984)

The "confusion" suffered by the commercial synthesizer, brought on by deliberately going beyond the boundaries which would define "normal" musical use of the instrument, resulted in music which presumably sounded anything but conventional. This type of "hacking" depends on "inside" knowledge of the instrument—a knowledge of its functioning deeper than that to be expected from the average musician—or at least an interest in investigating its potential, beyond the obvious. Tudor said, "an electronic component can seem to have a personality very much in the same way I try to make loudspeakers have a special voice. If you really examine a device that you might buy, like a filter or a small mixer, and you actually try to experience its capabilities, you have to push it, to ask it to do something that it's incapable of doing. When you make those experiments you find out that unique things are happening because you are influencing the electronics" (Tudor 1988a).

The one-paragraph manifesto which Tudor wrote for the Festival d'Automne programme book to introduce the working methods and objectives of *Composers Inside Electronics*, is perhaps his most concise and poetic statement on this topic. It is here transcribed from Tudor's handwritten draft version, which he entitled "The View from Inside" (a title not included with the published version):

The realm of electronics, entered into in the spirit of discovery, can give the musician a new world. Electronic components & circuitry observed as individual & unique instruments, rather than as servo-mechanisms, will more & more reveal their personalities, directly related to the particular musician involved w/ them. The deeper this process of observation, the more the components seem to require & suggest their own musical ideas, arriving at that point of discovery, always incredible, where 'music' is revealed from 'inside,' rather than from 'outside.' (music reveals itself) (Tudor 1976b)

This resonates with Paul DeMarinis' opinion that Tudor had a

[...] kind of animistic relation to [material objects ...] well, that things have spirits. The thing that you ring, the *Rainforest* object, the barbeque grill that you tap—maybe it's a barbeque grill to the rest of the world but it has this sound, this spirit, and I would say [...] the idiosyncratic electronics, the circuit that was only useful running inputs and outputs reversed, or the capacitor that in some circuits that was defective and had a very funny response curve that would break over at a certain kind of voltage... those things to me are along the lines of—figuratively—a kind of animism or shamanism or something where the power is within the unique object [...] the specificity of material is something that I felt very much at work in David's work. (DeMarinis 2001)

Alden Jenks, who as a graduate student spent time with David Tudor at Mills College in the late 1960s, related a very interesting anecdote which touches once again on Tudor's relationship to nature, and offers another provocative view on his interest in the technological:

I said to David something like, well, I proposed the sort of distinction between the urban person and the country person or the nature person and the machine person and asked if he didn't feel torn between those two, or asked where he put himself in that. And he said, you know, I feel that I am really a nature person, but as long as the...how did he put it exactly? The idea was, as long as the people in power control the technology, I'm going to be where the technology is. The message seemed to be: I'm going to subvert whatever they're using. [...] I'm just left with the general impression that what David was saying was that the military-industrial complex is using all of this stuff [... and ...] we were going to go to the surplus

stores and use all this military surplus stuff for very anti-war, altruistic ends. And I don't know, maybe David just threw that out off the cuff, but I have a feeling that it was a little deeper than that—that he was both stating a certain kind of political perspective and also talking about himself as maybe a more poetic guy than he necessarily let on. (Jenks 2001)

CIE: Realising experimental "classics"

Tudor's introduction to the Festival d'Automne programme book attempted to define his concert series in terms of a historical continuum:

[...] the works chosen for this series of concerts are not elaborated theoretical propositions, but rather they are direct demonstrations of perceptions & experiences & those works chosen from earlier years point directly toward our present electronic awareness(es). (Tudor 1976b)

The Festival d'Automne programming is of interest not only because it was the first occasion on which the members of the *Rainforest* performing group acted as an ensemble beyond Tudor's piece—the entire group of eight, including Tudor, performed together in three works apart from *Rainforest*, and the majority of the rest of the programme consisted of works involving collaboration between two or three players—but also because of its breadth. The following several sections of this chapter are given to an overview of this broad range of pieces.

Several of the works were already at that time "classic", stemming from the avante-garde of the early 1960s. Phil Edelstein says "To have these scores to work with [,] that gave us a grounding and vehicle to perform, to provide place and be able to live with these works was marvelous [but] In retrospect, I don't think these other pieces offered us the interior space and life that we found with *Rainforest*" (Edelstein 2005c).

This concert series is unique in the history of CIE; although the group performed many more concerts together, in various combinations, it did not again present works by composers from outside the group (although Takehisa Kosugi's *Catch Wave* was again performed by CIE in 1982, with the composer as a member of the group). The Paris concerts did seem to spur the notion of working as a performance collective, however: from that time on, works created by CIE members were performed in their concerts with the assistance of other members. This included David Tudor joining in on works by his younger colleagues, as well as invitations from him for them to join in performance of works other than *Rainforest 4*. John Driscoll says,

David was actively involved in them [performances of younger CIE members' works], not all, but specific ones. I think he would go through the menu, and sort of pick and choose the ones that were more geared to his methodology. Like he never performed the saw stuff [Driscoll's pieces incorporating bowed saw], or that. Yet, he did get involved in the *Ebers and Mole* [by Driscoll circa 1977-1979] and the *Interfeed* [by Driscoll and Edelstein circa 1976] type pieces because he liked that idea of sort of everybody doing parallel processing. And so, I think he sat in on pieces that tweaked him. Then at one point, he and I did a thing at Marymount together. *Dialects* [by David Tudor in 1984] and *It's in them* [Driscoll's *It's in them and it's just gotta come out*], the softer piece that I did. (Driscoll 2002)

Following the first day's presentation of *Rainforest*, the inclusion of *Cartridge Music* on the second day could be seen as directly tracing *Rainforest's* roots back to Cage's small sounding objects of 1960. John Driscoll has said that, for him, pieces like *Cartridge Music* were unfamiliar and challenging territory.

I specifically remember working on *Cartridge Music*, a piece I had heard on recordings numerous times and was familiar with. The issue was, familiarity with it and performing it were two different things. [...] I found it challenging because I thought John's [John Cage's] work was much less formal than the approach David had. For him the time considerations outweighed the gestural. He had a very exacting system with rigid timings. [...] David, in his fashion, always took a very unique process to interpret other peoples' work

and this was a part of him most of us learned about first hand with these works". (Driscoll 2005b)

Phil Edelstein said that he had a little more familiarity with performing Cage and "had probably first learned of the Cage pieces from classes with Joel Chadabe—this was kind of Music 101 for me. I wouldn't say I knew the pieces well but in a limited way was 'schooled' in this. I certainly was more exposed to graphical notation and Cage's work and knew more about this literature than anything with notes and staff" (Edelstein 2005c).

Tudor has clearly described his approach to the performance of *Cartridge Music* as including a semi-improvisational "freedom of interpretation" which one might not expect from the score materials and instructions:

All the instructions were given. All you had to do was to do "what it said" and bring about a performance score for yourself. However, in doing that, there are a lot of small things which cause you to actually alter the readings you got from the score. For instance, for the determination of time, John Cage had employed a clock on transparent paper which goes around from one to sixty. Well, one thing which I discovered very early on was that when you are performing, there are lots of things you have to do besides looking at a stopwatch or thinking about the time. So after a while, you think, 'Oh, I was so late, what am I going to do? I'm supposed to hurry,' or, 'the time is so long, I have nothing to do, what shall I do?' So after looking back on it you decide, well, it's not important what minute it is, it's only important what second it is, so then you see that if you make your determination only reading the second hand and it does not say what minute it is, then all of a sudden you are giving yourself a freedom of interpretation which you didn't have before. (Tudor 1988b)

The younger CIE members clearly took their roles seriously: Driscoll's own score derived from readings from the *Cartridge Music* materials (a set of randomly overlaid transparencies from which to make many graphic "readings") is extremely elegant and precise (see Figure 6-6) (Driscoll 1976); two other sets of score readings obtained, one by Phil Edelstein and the other unattributed (Edelstein 1976a), are well organised

and show a great deal of attention to detail. Phil Edelstein said, "I have recollections of an absurdist and dadaist bend to *Cartridge Music* which contributed to the fun of the piece. The trick was not camping it up—I can't recall whether we strayed over that line" (Edelstein 2005c). John Driscoll, however, mentioned the stress that Tudor experienced in "stepping out on a limb" with this new venture, and says that Tudor was even "angry at times" with CIE members' "looser approaches" to *Cartridge Music* and the other works they were tackling (Driscoll 2001b):

I think he was a little frustrated probably because at first I don't think we took the same way he did. And, you know, it gets to be a very theatrical piece, and I think we were more interested in the theatre of it than maybe the precision of it [...] I think we were inclined after seeing David's piece to clean up our act [*laughs*]. (Driscoll 2002)

A letter from Ralph Jones to Tudor, hand-delivered just prior to final rehearsals in Paris before the Festival d'Automne, references this friction and reinforces the role of Tudor as mentor to the group.

Dear David,

I'm sure this seems a bit silly, but I'm writing you because I've something I want to say to you and I know I won't get the chance very soon with rehearsals beginning tomorrow...

It's seemed that you've been a bit disturbed lately, and I fully understand why -- I think we all feel a bit pressed now... What I've really been worried about, however, has been the things you have said about our attitude toward the whole endeavour, particularly toward the finances, and I feel a need to answer you somehow, for myself at least.

[...]

Not only do I feel a part of this group, deeply committed to what we are doing and given the opportunity to present my own work, but we are all being paid very handsomely, far better than I ever was before for performing, much less for performing what I like to perform. ... I know very well, from experience, that only you could give this to me.

The most important thing I have to say, however, is that all that, in a sense, doesn't matter to me at all. The one thing I am most grateful for, the one thing that makes everything more than worth it to me, is the opportunity once again to work with you, and to be close to you, to enjoy this beautiful city and the music making with you and with our friends.

[...]

...I'm getting carried away when all I really want to say is that I love you, I'm eternally grateful for what you're trying to do for all of us, and I want only to do my best for you. I always have felt this way, and I always will. I just wanted somehow finally to say it.

Love,
Ralph

John Driscoll was not the only one for whom these pieces were new territory: Linda Fisher, responding to Tudor's invitation to join in the Paris performances, wrote

What a high to do RAINFOREST in Paris. I'd love to, as a matter of fact. Will we have advanced instruction and assignments for the 'group pieces'? CHANGING THE SYSTEM [by Christian Wolff, not included in the final programme] is the only one you mentioned that I have worked on, although I am vaguely familiar with [John Cage's] ATLAS ECLIPTICALIS". (Fisher, 1976)

In August of that year, with the Festival D'Automne drawing close, she wrote to Phil Edelstein,

I received a letter from Tudor in which he mentions Catch Wave, transmitters, receivers etc. exploring the variables. Since I do not know the piece and haven't got a score, I'm a little mixed up—David writes as though he assumes I know all about it—for example "YOU SHOULD TRY TO FIND SOME THEATRICAL ACTIVITY WHICH MEETS THE PERFORMANCE REQUIREMENTS AND IS INTERESTING TO LOOK AT". WHAT are the performance requirements? David says you and he have some transmitters. Is this true? Should I be worried about this piece now or can I worry about it when I get to N.Y.C.? (Fisher 1976b)

	1	2	3
	1 (5) AUX. 2 (2) 3 (3) 4 (4) T — 5 (1) / VOL.		2 TONE
	6 (6) / VOL. 7 (3) 8 (8) AUX.		
	9 (4) (3) 10 (5) AUX 11 (6) VOL. 12 (7) VOL. 13 (6) T —	(1) AUX. (2) CHANGE	
	14	(4) VOL. (5)	(1) AUX. AUX.
	15 16		
	17 (4) CHANGE 18 (4) 19 (4) T \		
	20 21 (4) AUX. 22 (6) AUX. 23 (8) TONE /		
	24 25 (8) 26 AUX. (8) 27 AUX. (8) 28 (3) TONE		
	29 REPEAT VOL. ✓ 30 AUX (6) BALL THROUGH PIPE 31 AUX (5)		

Figure 6-6. Detail from page one of John Driscoll's score realisation for CIE's performance of John Cage's *Cartridge Music* at the Festival d'Automne, Paris 1976 (Driscoll 1976).







	1	2	3
	1 ⑤ AUX. 2 ② 3 ③ 4 ④ T - 5 ① / VOL.		2
	5 ⑥ / VOL. 6 ③ 7 ⑧ AUX 8		
	9 ④ ③ 10 ⑤ AUX 11 ⑧ VOL. 1 12 ⑦ VOL - 13 ⑥ T -	① AUX ② CHANGE	RAISE RACK
	13	④ VOL 1	① AUX.
	14 15 16		② VOL ③ AUX.
	17 ④ CHANGE 18 ④ 19 ④ T \		
	20 21 ④ AUX. 22 ⑥ AUX. 23 ⑧ TONE /		
	24 25 ⑧ 26 AUX, ⑧ 27 AUX, ⑧ 28 ③ TONE		
	29 REPEAT VOL. ✓ 30 AUX ⑥ BALL THROUGH PIPE 31 AUX ⑤		

Figure 6-6. Detail from page one of John Driscoll's score realisation for CIE's performance of John Cage's *Cartridge Music* at the Festival d'Automne, Paris 1976 (Driscoll 1976).

Cartridge Music was familiar territory for Tudor, who had performed it many times with Cage since 1960—most recently the piece had been used as accompaniment for a 1975 Cunningham dance entitled *Changing Steps*—and the other "classic" experimental works for the entire group to perform on the Paris programme were also well-known to him.

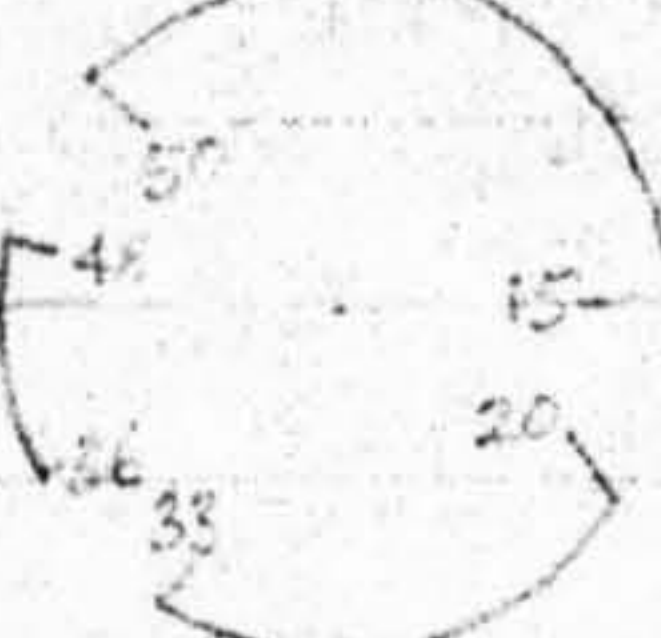
Cage's *Atlas Eclipticalis* had received its first concert performance in 1961 with Tudor as pianist, and the piece subsequently accompanied Cunningham's 1961 dance *Aeon*. For the Festival d'Automne Tudor prepared instructions to CIE for their group performance of a percussion-only version which seem to hew closely to the means and sonic world of *Cartridge Music*: "Resonant tray, amplified (contact mic) surrounded by 3 percussion instruments, also amplified, controlled with mixer [...] N.B.: for performance on trays, & perhaps also on instruments, use a collection of minute objects, e.g. paper clip, thumb-tack, pipe cleaner, marble, nail-file, feather, etc. etc." (Tudor 1976c). Like *Cartridge Music*, the piece was performed by the entire group of eight.

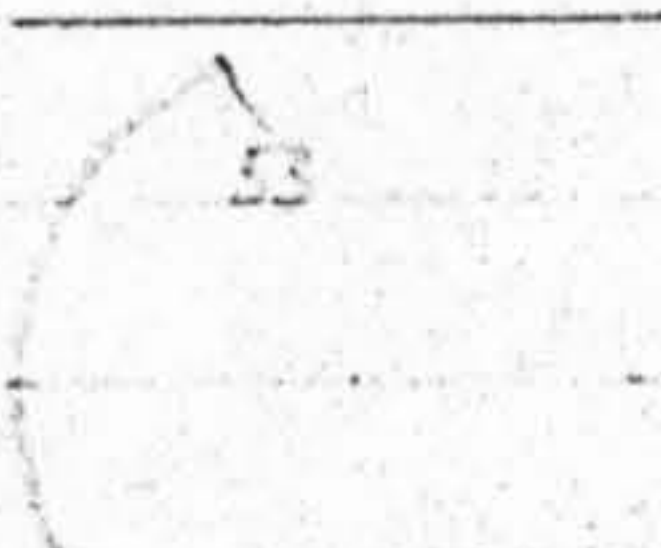
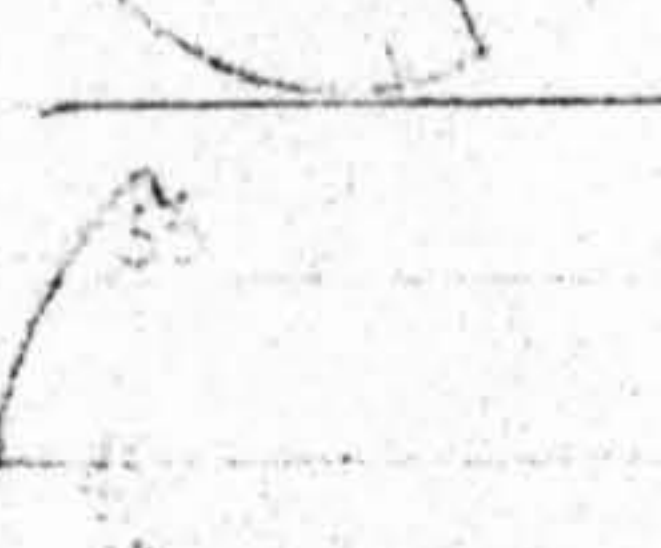
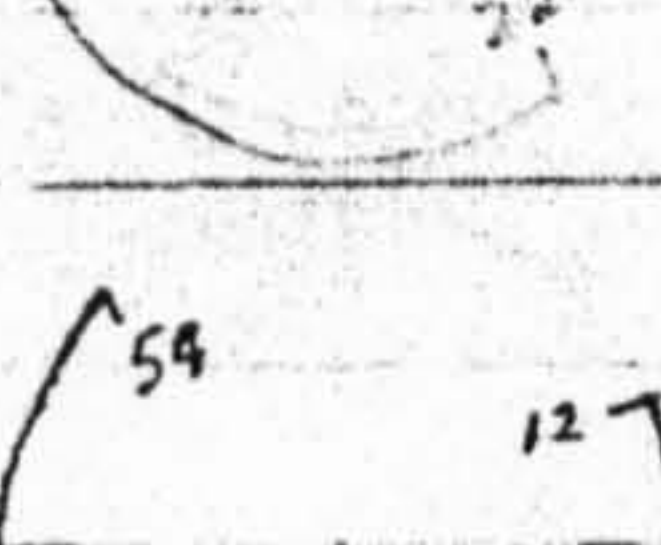
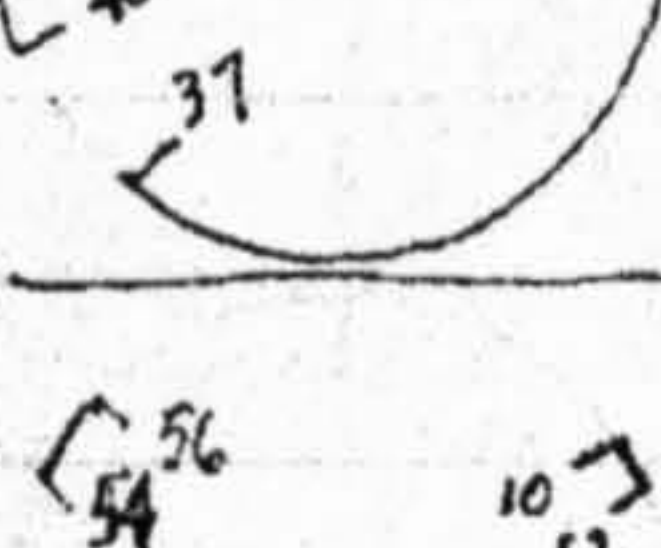
Also performed by the entire group were Takehisa Kosugi's *Catch Wave* (1965/69) and Toshi Ichiyanagi's *Sapporo* (1962). The former was described in the Festival programme book as depending on "interaction of one to eight transmitter and receiver sets" and in Phil Edelstein's notes was said also to involve a hot plate, frying pan, and a spatula. A bicycle, propane torch, thin brazing rods, and rotating fan were also requested for the performance (CIE 1976c). The piece has been described as "electronic fishing" with portable radio receivers, with the presence of the audience also affecting the distribution of signals (Sakuramoto 2001). Takehisa Kosugi's note for the Festival programme book reads: "AM radio receivers are adjusted to produce frequencies and AM transmitters are set up close to the receivers. Movements in the room create the actual performance of the music" (CIE 1976b).

Phil Edelstein says that *Catch Wave* "in a way was going back to my radio roots—and by 1976 not at all an unfamiliar leap to use this for performance. I had been playing with radio electronics since the early 60's [and] to find a situation to continue these machinations with others was just the best". He recalls as part of the performance "I wound up cooking spaghetti at one point—I think one of my *Catch Wave* antennas was a wooden cooking spoon—not sure I was wholly successful there" (Edelstein 2005c).

Toshi Ichianagi's *Sapporo* is based on a graphic score and lengthy text instructing the performers in subtle interactions which recall the complexities of Cage's *Cartridge Music* instructions, or those of Christian Wolff's *For 1, 2 or 3 People*. Instrumentation for *Sapporo* included (according to Edelstein's list) cross-coupled oscillator, hammer and caps, toy pellet gun, bowed metal box, and bubble wrap (Edelstein 1976b). Also requested from the Festival for *Sapporo* were a contrabass, small gong, washtubs, and a pedal steel guitar (CIE 1976c).

The only non-group performance of a piece falling into the "historical" category was Tudor's solo presentation of Richard Maxfield's *Piano Concert for David Tudor*. First performed by Tudor in 1961, in the series of concerts organized at Yoko Ono's loft by La Monte Young, the piece is another based on simple amplification via contact microphones, in this case of a grand piano ("not in very good condition, tuning not necessary" (CIE 1976c)) played without touching the keyboard, but rather by manipulating various objects inside the piano: for instance, setting gyroscopes spinning, making frictional sounds with rubber and other materials, or letting plastic tiddlywinks rain down on the strings. Following a graphic score, Tudor played the piece as a solo, accompanied by several prerecorded tapes of similar piano material as processed by Maxfield (the same combination of tapes was never repeated from performance to performance).

Original CIE works at the Festival d'Automne

Six original works by members of the group were presented in the Paris series, ranging from new pieces created for the occasion (Bill Viola's *Gong*) to one piece dating back to the 1973 workshop in New Hampshire (Martin Kalve's *Et puis... et puis... est-ce que je puis?*). They also represented a wide range of relationships to the mode of operation which Tudor had articulated for Composers Inside Electronics; the greater proportion—those by DeMarinis, Edelstein, and Driscoll—are very much described by Tudor's manifesto regarding the relationship between composer and instrument, in that they depended on a substantial amount of home-built circuitry. Kalve's *Et puis...* and Viola's *Gong* were apparently less dependent on unique circuitry and more focused, like *Rainforest*, on the resonance of sounded objects.

Gong, performed by Viola and Fisher, employed "resonances of a suspended metal gong, amplified by a microphone and diffused through loudspeakers" (Musée d'Art Contemporain de Montréal 1996). The "gong" was a 17"x25" metal acetylene tank (Edelstein 1976b) with one end cut off, played in a performance that employed a mandala-like image in its creation of "a situation of continual expansion from a given center, the Bell" (CIE 1976a). The piece had some of the qualities of a "performed installation", as its sound occupied several rooms: "Sound will grow from the physical material, to the room space, overflowing to adjoining rooms, finally travelling out through open windows or doors to connect outdoor space with indoor" (CIE 1976a). This was achieved with a shotgun microphone pointed at the gong, and a series of sound systems occupying adjacent spaces, with the performance rendered highly theatrical by use of a 1000-watt spotlight focused on the gong and its player. A recording of the piece from The Kitchen in New York City in January 1977, several months after its premiere in Paris, reveals an extended structure which begins with a section of about four minutes'

duration in which sympathetic resonances of the gong are activated by Viola's voice: quasi-pitched yelps cause the gong to ring and its partials are brought out by careful manipulation of the amplified signal (presumably by Fisher). This is followed by a much longer section (approximately 35 minutes) in which the gong is struck repetitively in various ways, at varying rates, creating a shimmering wash of inharmonic partials (Viola 1978).

Martin Kalve's *Et puis... et puis... est-ce que je puis?* was staged as a piece requiring audience participation, much as it had been at the 1973 workshops in New Hampshire, and like *Gong*, it had the character of a performed installation. On this occasion, a sewer pipe 92 inches in diameter and 20 feet long was requested by Kalve for the piece's "large resonant object", to be sounded by the audience tossing "60 styrofoam balls of varying sizes", at the rate of no more than one every 20 seconds (CIE 1976a), with the pipe amplified via contact microphones. The French-language festival programme included the detail that "amplification is subject to the influence of movements of the room" and made the participatory nature of the piece into an existential exercise: "For the realization of this work, each person must make a decision, the artists and the public. This decision can be avoided or delayed, however the longer one delays it becomes more difficult and necessary to act" (CIE 1976b).

Paul DeMarinis' *Molimo* was performed as a duo, with Martin Kalve on viola, processed through DeMarinis' circuits. Described as a version of an earlier piece, *String Quartet for Viola and Voltage Controlled Audio Delay Circuits*, it involved processing including "frequency modulation, simulation of endless ascending and descending, and generation of several accompanying string tracks derived from the original signal" (CIE 1976b), achieved through analog delay circuits. The piece is prefaced in the Festival's programme book with a quotation from anthropologist Colin Turnbull's *The Forest People* (which was also an inspiration for Merce Cunningham's dance *RainForest*, as mentioned in Chapter Three),

describing customary treatment by the Mbuti pygmies of central Africa, of their *molimo* trumpets (CIE 1976b). The quotation centers around rituals of behaviour—in this case, the pygmies' convention of giving their trumpets a "drink" when crossing a stream—which remain constant as technology changes: according to Turnbull's informant, the Mbutis' traditional wooden trumpets were improved acoustically by dipping in water; some newer trumpets were fashioned of metal but the dipping was still observed even though their acoustics went unchanged. The quotation (Turnbull 1968, 89) seems to serve as commentary on the bringing together of old and new technology in DeMarinis' piece, and the possibility of customary practices and familiar behaviours influencing its performance, alongside the technological shift to virtual string quartet. DeMarinis recalled that it was the disruption of the familiar which modified the piece during its performance: "Martin, being the trickster that he was, decided mid-performance to change the communication system that we had going between us" (DeMarinis 2001).

DeMarinis' second contribution to the Festival d'Automne, an installation entitled *Pygmy Gamelan*, was described as an "electronic circuit composition designed for environmental performance" (CIE 1976b). The piece, developed in 1973, consisted of a number of small, identical handmade circuits driven by a clock pulse generator which provided a standard tempo for melodic material. Two repeating patterns in a pentatonic mode were achieved by ringing highly resonant tuned filters with trigger pulses, where the accumulation of pitches into melodic phrases was determined by a random input: an antennae sensitive to "electrical disturbances in the environment (60 cycle hum, radio fields, etc.)" (DeMarinis 1973). If electromagnetic activity in the immediate vicinity was detected by the antenna input at the moment of a clock pulse, a new two- or three-note pattern would be initiated. Four of these circuits playing and responding to "electrical fluctuations in the galaxy" (DeMarinis [undated]) created a pulsing texture of pentatonic patterns, "perpetually changing but bound to the metric and modal constraints

designed into each unit. In this sense, the electronic circuit itself functions as the score, as well as the instrument and the performer" (DeMarinis 1973): it would be hard to imagine a more complete exposition of the name "Composers Inside Electronics" in its synthesis of the three.

The piece was also an interesting commentary on the "folk instrument" aspect of homemade circuitry: the programme book notes that "The integrated circuits used are nothing but cheap surplus components originally intended for consumer products. Their uses here are entirely folk, however, and, like products made of plastic which spread through primitive societies, they tend to refer to a culture different from that of high technology" (CIE 1976b). The title of *Pygmy Gamelan* may have simply been a humorous description for a grouping of "little electronic circuits" (DeMarinis undated) playing together in a five-note mode reminiscent of the *slendro* scale found in Javanese and Balinese gamelan music. The pygmy reference however, following on the Turnbull quotation prefacing DeMarinis' *Molimo*, shows a fascination and tongue-in-cheek engagement with the ethnographic. Both of DeMarinis' pieces play with images of life in the "real" rainforest, and it is interesting to note that when he eventually released a record of *Pygmy Gamelan* in 1980 (under the title *Forest Booties*), it was mixed with a recording of "the quiet sounds of the forest" to give the effect (with tongue in cheek again) that it had been documented by a field recordist (DeMarinis 1980).

Similar to DeMarinis' conception for the *Pygmy Gamelan*, Ralph Jones' installation piece, *Circuitree*, from 1974 also featured "autonomous" circuits responding to changes in the environment, in an even more direct relationship to the "natural" forest. Installed in the courtyard of the Musée Galliera, *Circuitree* comprised five "independent, but functionally identical sound-producing circuits, designed to be placed in trees" (CIE 1976a). Unlike *Pygmy Gamelan*, which was driven by a central pulse

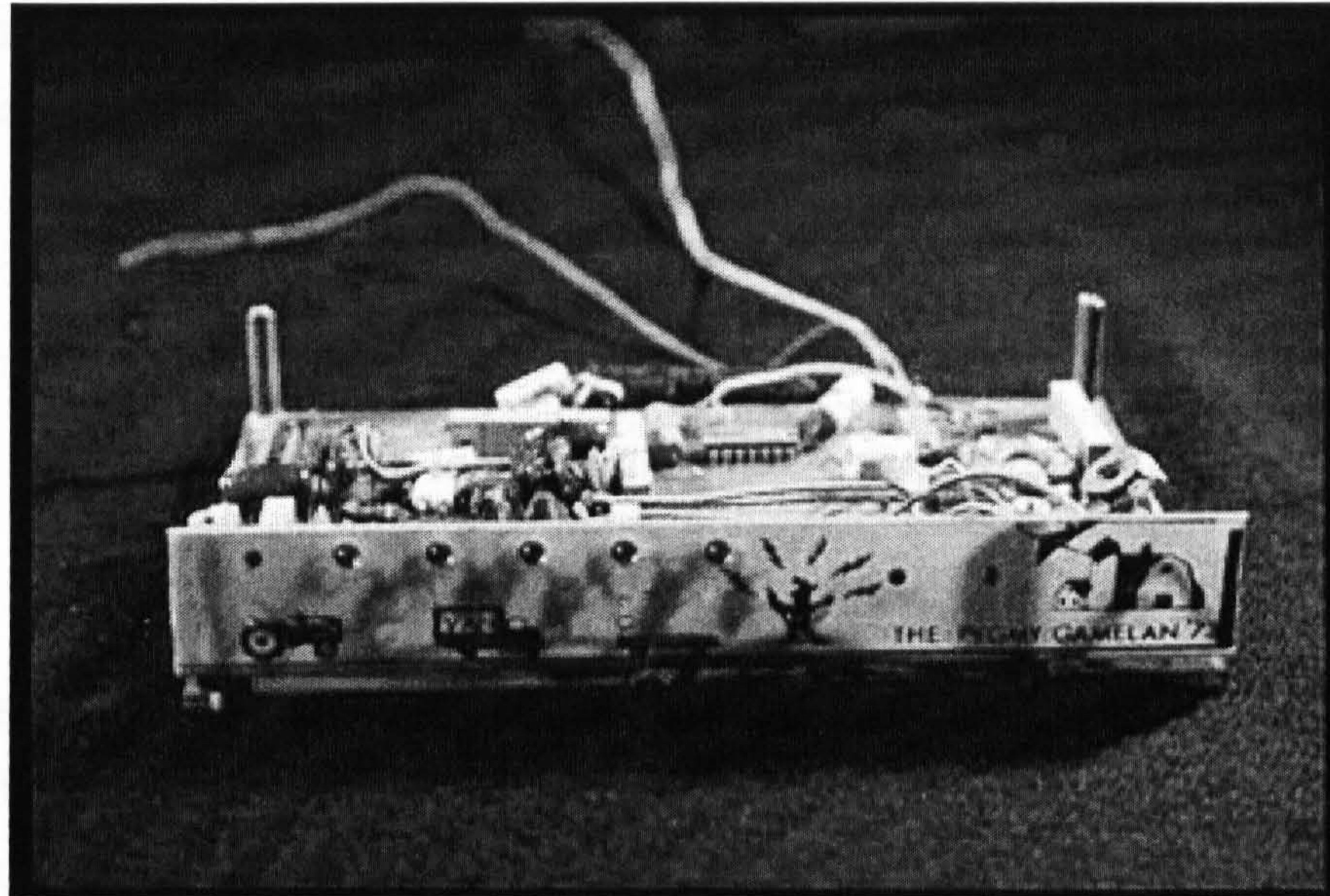

Figure 6-7. One of Paul DeMarinis' 4x7 inch *Pygmy Gamelan* circuits. Photo courtesy Paul DeMarinis.

generator as "conductor", the five circuits were not linked; each produced sound which varied with changes in its immediate environment, using sensors to detect variation in wind, light levels and temperature. The conversion of the courtyard's trees into "singing" sound sculptures, creating a continuously changing environment (Leonardini, Collin and Markovits 1982, 254), seems a clear response to, or reflection of, *Rainforest*. Jones described the piece as a

[...] first attempt to deal with a larger scale of space location and time (both duration and rate of change), musical proportion as an aspect of electronic design, and relation with a natural environment (in terms of time, space scale and acoustics). (CIE 1980a)

Jones' second installation for the Festival d'Automne had the character of an informative exhibit rather than an artwork. *Sources of Naturally-Occurring Ultrasonics* was a collection of documentation with the objective of revealing "an acoustic world of which people are not generally conscious" (CIE 1976a), that of sounds above the range of human hearing. This followed on a research project of the same name

which he had begun in the spring of 1976 at SUNY Buffalo, where he was a graduate student.

My master's thesis in music composition, if you can believe this, was to design and construct a transposing microphone for ultrasound, that picked up a sound between 20,000 and 100,000 cycles, in 20,000-cycle slices, and using a heterodyning technique transposed it down to the audible range. And then I investigated all these different natural sources, principally insects actually. (Jones 2001)

Jones recalled recording expeditions with his new ultrasonic microphone into the fields surrounding his home of the time (a deconsecrated church near Buffalo), collecting sounds for use with experimental *Rainforest* objects:

I had this huge, enormous sanctuary area and I always had *Rainforest* objects hanging, and that was where I would develop new objects, very large-scale objects. And I'd get up in the morning and turn on *Rainforest*. You know, listen to some shortwave [radio] through some big object I was working on. And in the fields surrounding this church, I would go out in the midsummer with this [ultrasonic] microphone, and hear really not much of anything, and then put on the headphones and turn this thing on, and there would be a cacophony, just a huge variety of sounds. All this activity was occurring above our range of hearing, it was like having a telescope and seeing the moons of Jupiter or something. So I built up a fairly good library of those sounds and I used those a lot also.

The "science fair" aspect of Jones' ultrasonics installation differentiates it from the rest of the CIE program; along with videotapes, photography and audio recordings, "detailed theoretical information" stemming from Jones' research was also part of the exhibit (CIE 1976a). Jones went on the following year to obtain funding to enable development into a second version of his transposing microphone, and throughout the 1970s continued his "investigation and documentation of the acoustic world above the upper frequency limit of human hearing" (CIE 1980a). Several years later, John Driscoll also began working in this area, involving ultrasonics in live performance.

Interfeed, Driscoll's collaborative performance with Phil Edelstein at the Festival d'Automne, was based on the idea of a common set of sound resources shared between two or more players, developed during performances in 1975:

I was interested in the idea of a sort of a loop, and Phil and I had talked about this extensively, about a loop performance you know, where we pass signals, and there'd be sort of a pot of signals that were available and parallel to everybody. Then people could process them and output them in their own way. (Driscoll 2002)

Interfeed is referred to by Driscoll and Edelstein in interviews as "the *Interfeed*" (Edelstein 2001) or "an *Interfeed*" (Driscoll 2002), and in fact Driscoll says that *Interfeed* was really not a composition, but rather

[...] a collaborative structure, in my mind. In other words, it would be like, you know, these days going, well, let's set up an ethernet network, you know, a protocol [... so] that we could then co-ordinate together. So, it was [...] a sort of an archaic way of saying that we want to build a certain architecture to which you can work. (Driscoll 2002)

Reinforcing the notion that the piece was not a composition in itself, but rather the description of a performance situation, is the fact that *Interfeed* is not named in Driscoll's, Edelstein's, or CIE's biographies or works lists from the later 1970s and early 1980s. The piece Driscoll presented as part of CIE's four evenings at The Kitchen in New York City in 1978, *Ebers and Mole*, is identified on its score diagram as *Ebers and Mole - Interfeed*, however; Driscoll says that in that case, "*Ebers and Mole* was the source material, and then the 'interfeed' was the process we used to perform it" (Driscoll 2002). Phil Edelstein says that the idea of the interfeed began with the question "how do you kind of guarantee a kind of collaboration?", in an artistic climate where collaboration and improvisation were synonymous. "Essentially, the performance would come out of the constraints put on somebody" (Edelstein 2002).

Edelstein's second duo performance during CIE's week-long series was a literal investigation of constraints, and involved the collaboration of an uncredited performer, dancer Marsha Heather Harris, under the title *Zabriskie Point*. The piece began in 1974-75 as a Moog synthesizer patch based on "a series of cross-coupled oscillators" in the studios at SUNY Albany:

It has absolutely nothing to do with the film [*Zabriskie Point*, by Michelangelo Antonioni 1970]. The irony is that Zabriskie Point is also a parking lot. There's an overlook that's very, very beautiful and I had the tape that I'd done in the studio in Albany [...] I was traveling around and did a wonderful trip to Death Valley [...] I played the tape there and relabeled the tape which was sort of unnamed at that point. (Edelstein 2002)

There were a bunch of elements that I found attractive: a composed formulaic structure, bilateral symmetry (cross coupled banks of oscillators and VCAs), intertwined control and audio paths, a system that could produce non-linear output based on linear control inputs, ability to produce a sound field, spectral and tonal diversity, a landscape created from fairly simple circuitry, and i thought it had a ripping good sound. i was delighted in stumbling into an integrated system that could produce pitched and near white noise'ish sonic structures from the same basic engine.

[...]

Zabriskie Point turned out to be an overlook with a parking lot. I was sitting on the hood of a VW and playing the tape which struck me as going very well with the landscape. (Edelstein 2005c)

Edelstein wrote for the Festival d'Automne programme in 1976 that "The piece crystallized on observing how tourists at Zabriskie Point were attracted to the scenery". As actually performed, however, Harris and Edelstein's piece had quite a different point of reference—an enactment of husband/wife relationship complexities—and ought to have been presented under the title which was used for subsequent performances: *Shrieks and Nuptials*. Edelstein says "I probably had submitted program notes for Paris well before solidifying the shape the presentation would take and including the adaption for dance with Heather" (Edelstein 2005d). The programme note for a performance of *Shrieks and Nuptials*

with CIE in New York City several months after its Paris performance describes the piece ambiguously: "Where the action of both performers establish the changes of sound. In which a dancer/wife performs with electronic/husband without finding themselves in a compromising situation" (CIE 1977a).

Edelstein's original patch was based on "feedback loops between pairs of oscillators and VCAs and I remember it being fairly complicated and using almost the whole studio, which was a wall of Moog" (Edelstein 2002). This version of the piece was soon, however, recreated in miniature:

I figured out how to build a relatively portable circuit that had a bunch of these elements that could fit on a table top, be carried around in a suitcase, taken on the road and used as an instrument in performance. The key was Exar 2206 function generators. I was able to come up with an instrument that could be used in performance costing probably around \$75 in parts and some hours to build rather than \$100,000 studio. I wound up with a small aluminum chasis with open faced electronics and a bunch of 100 turn potentiometers adjustable with a jeweler's screwdriver that I could tweak and get the thing to squawk. (Edelstein 2005c)

For the Paris performance, Edelstein says he "was thinking of this as a small theatre piece without words activated with the two characters who could explore a range of quasi independent activities. The result is an allegory about their relationship under various degrees of dynamic tension constrained through technologic artifice" (Edelstein 2005c). The two performers engage in a literal struggle requiring physical effort on the part of the dancer, who strains at "a large piece of wide elastic, probably 20 or 30 feet long, that could stretch to 30 or 40 feet" (Edelstein 2002). This was attached to a school desk (the folding type that "have a chair with an arm and a little writing surface"), where sat the electronic musician with his circuits. Harris attempted to exert enough force to drag Edelstein around the room. The elastic was connected to a modified footpedal which was part of the circuitry mounted on the chair; as Harris pulled, she influenced the circuit towards stasis and silence, while

Edelstein, seated, made adjustments to the circuit with his screwdriver, attempting to compensate for Harris' activity.

The piece is performed by the performer in the chair adjusting his dandy little circuit looking for wonderful little sounds in the dynamic balance with the dancer doing her improv thing applying a certain amount of physical force over the best laid plans of the guy with the electronics. The voltage controlled by tugging on the elastic rope was combined with controls I had—by upping setpoint for silence, more force was required and silence would only be achieved with enough force at the edge of dragging the chair around. (Edelstein 2005d)

Beyond the amount of force necessary to achieve silence, Harris' pulling caused the circuit to produce sound again: "silence at a moderate amount of force, and then at either no force or full force it symmetrically went the same way. So it was shaped like this: with no force on one side and full force on the other, and silence right in the middle" (Edelstein 2002). The piece addresses male and female stereotypes with a presumably ironic eye and ear: the technologically preoccupied man (or schoolboy?) who is nominally in control, focused on adjusting his circuits, is engaged in a struggle with the expressive, emotional woman, who attempts to silence the technological object of his attention, and to physically (and perhaps emotionally) move him. In the context of the almost entirely male CIE, this piece seems remarkably self-reflexive; Linda Fisher's thoughts on gender dynamics within the group are interesting to consider in this regard and will be addressed in a later section of this chapter.

John Driscoll's *Listening Out Loud*, performed as a trio by Driscoll, DeMarinis and Viola, is the remaining original CIE work from the Paris series which has not yet been mentioned. Originally composed as accompaniment for a dance by Maida Withers' Dance Construction Company, the piece combines elements of *Rainforest*, sonic explorations of space similar to that of *Gong*, and a live performance element unlike any of the other works performed. With reference to the score diagram (Figure 6-8), the basic signal path begins with microphone input from two

musical saws, played by Driscoll and Viola. High-pitched glissandi from the saws are sent to the PA system both directly and as processed by several types of modulation (single sideband, FM and AM). One of the saws is tapped for a feed to a sound system in an "external resonant space", acting as an echo chamber, with a microphone bringing the reverberated signal back into the main performance space (the work was said to have been composed for dark, resonant space such as caves (CIE 1976b,1977)).

According to the diagram, and descriptions of the piece written by Driscoll, the musical saws' signals control a signal switcher which determines which of several sources will be sent to the PA system—either the direct signal from saw #1, the processed versions of saw #1 or saw #2, or the output of a Norelco variable-speed cassette tape recorder. As described in the Festival programme book, which seems to contradict the diagram, the tape recorder is in fact the heart of the piece: "the saws do not produce sound directly, but their signals are used as a control for the electronics" (CIE 1976b), specifically to control playback speed of the tape recorder. There are further differences between the various descriptions available for the piece, and its score diagram: an alternative version of the 1976 description reads: "The electronics control the pitch and volume of previously recorded saw material, which is simultaneously mixed back in with the live sound of the saws" (CIE 1976a); a 1977 description states that "The electronics are responsive to the pitch and volume of the saws, and in turn control the speed of previously recorded saw material" (CIE 1977a). In the case of the Paris performance, the programme describes the prerecorded material as having been derived from a previous performance in Washington D.C. as well as from a paddleball court at Brigham Young University (CIE 1976b). The score diagram indicates that the Norelco tape recorder might also, in some cases, have been self-modulating, with its own output connected to the device which controlled its playback speed.

LISTENING OUT LOUD (TRIO)

john driscoll

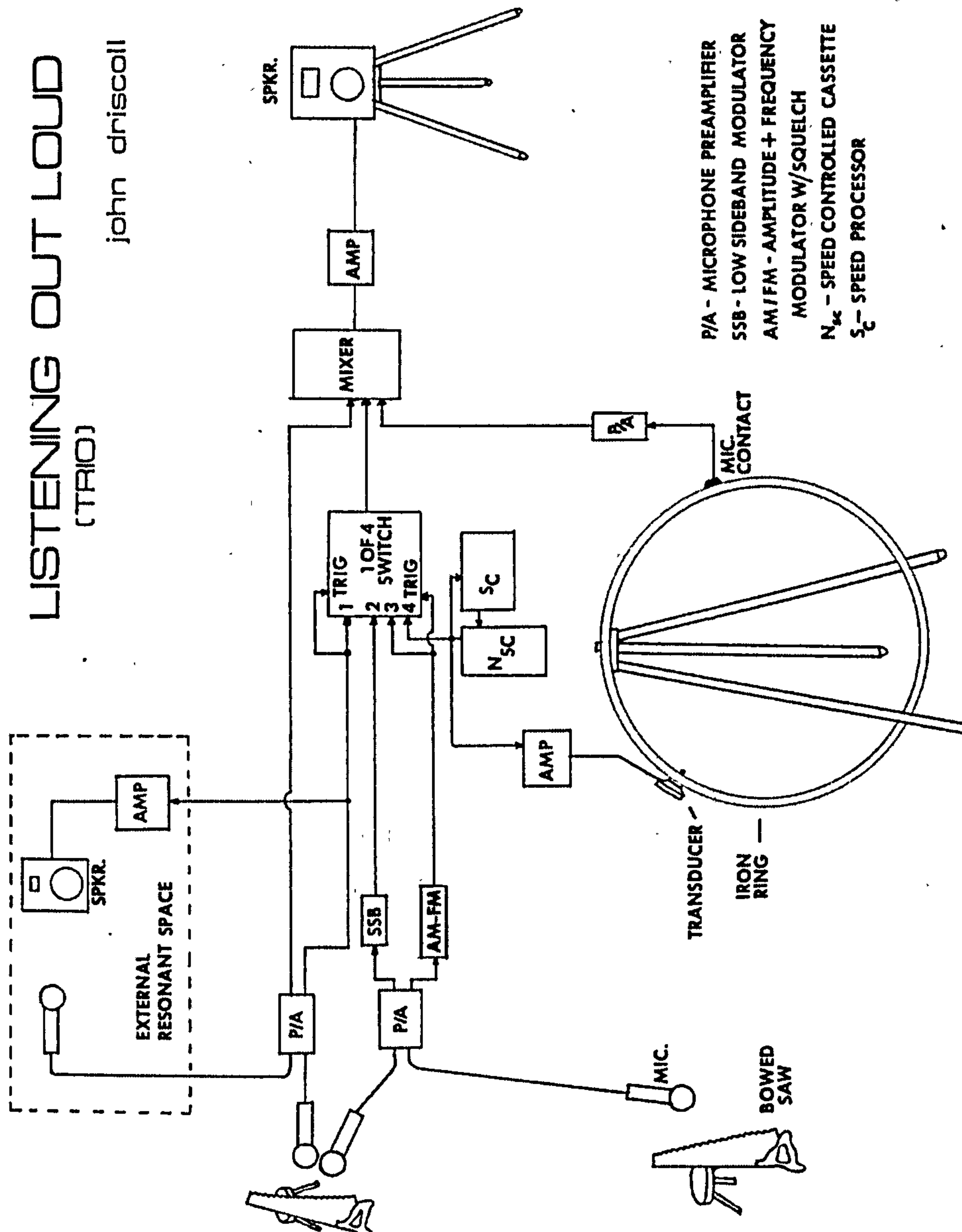

Figure 6-8. Score diagram by John Driscoll for his *Listening Out Loud*, in a version similar to that presented at the Festival d'Automne 1976. Courtesy John Driscoll.

According to the diagram, the output of the variable-speed tape recorder was sent both to the signal switcher, and also to a transducer connected to an iron ring used as a resonator, *Rainforest-style*, and the resonances

of the object were then amplified via a contact microphone, and heard through a conventional PA system along with the saw signals (one channel returning from the "external resonant space" and one coming from the "1 of 4 switch" which selected between direct and modulated saw signals), and the direct output of the variable speed tape recorder. The difficulty of parsing out the "exact" setup for this piece based on several descriptions reflects the likelihood that the piece was performed differently on different occasions.

CIE compositions unperformed

The only CIE member who did not present original work at the Festival d'Automne was Linda Fisher; she had initially indicated an interest, writing to Tudor, "I am willing to perform a piece of my own but I don't know what on earth it will consist of because it is as yet unformed. I am not very interested in past work in terms of future performance" (Fisher 1976a). In a letter to Phil Edelstein in August 1976 she referenced a new piece which she was apparently developing: "after I spoke with you things became more chaotic, then very clear, finally clear—so the piece goes on".

Fisher later said, of her decision not to present her own work in Paris,

I felt very self-conscious about bringing the kinds of pieces I was working on, which were synthesizer-based, to the Composers Inside Electronics, because... for those various reasons. You know, it would just look so odd to show up with all these keyboards when the whole idea was that we build our circuits and that's what we do. So, I remember when we went to Paris, we were all supposed to—if we wanted to—bring a piece to perform there. And I purposefully didn't, because I felt so conflicted about all that that I didn't bring a piece (which I've always felt badly about). And I think I did that same thing a couple other times. (Fisher 2003)

An early draft concert schedule for Paris shows a Fisher composition entitled *Star Point Crossing* included on the fifth day; other hints of works

that might have been programmed for Paris include three other pieces with program notes, listed along with descriptions of the others which eventually were performed; these are interesting to consider, for the variety of approaches to musical experiment which they suggest.

The first piece, *Median Strip*, is described as a continuing response to the experience of *Rainforest*, being based on a loudspeaker-object originally developed for Tudor's piece, but differentiated from that work in "combining and transforming personal sound imagery in an attempt to evoke the ever-changing textures, rhythms and intensities of my inner reality" (CIE 1976a). The second, *Music for Louise Montalescot*, has no description beyond a paragraph quoted from early 20th-century French experimental writer Raymond Roussel's *Impressions of Africa*, describing the unusual sonic uniform of that novel's character Montalescot, which surgically directs breath from her lungs through military-style braid, producing musical tones. The third piece listed, perhaps the same referred to in the letter to Edelstein, is titled simply "Work in progress", and is described as a pattern-based composition using "long, repetitive phrases which sometimes include silence and short, rapid rhythmic patterns" which move in and out of phase with each other, creating "a gradually unfolding sequence of relationships" (CIE 1976a), suggesting a piece perhaps similar in character to the quasi-minimalist pattern-oriented compositions for which her former ensemble, Mother Mallard's Portable Masterpiece Company, was known.

Although Fisher did not eventually present any of these pieces in Paris, she did assist David Tudor as co-performer in his piece *Microphone*, in addition to co-performing Viola's *Gong* and participating in the ensemble performances detailed above.

Additional Tudor works presented at the Festival d'Automne

In addition to programming a wide range of works from the 1960s which he stated "point directly toward our present electronic awareness(es)" (Tudor 1976b), and inviting his younger CIE colleagues to contribute their new work also exhibiting those awarenesses, Tudor presented two works of his own besides *Rainforest*, which should be mentioned. Both were presented on the same evening, and each depended on a different type of feedback for its sounds: acoustic feedback in the case of *Microphone*, and electronic in the case of *Pulsers*.

Microphone, first realized at the Pepsi Pavilion at the 1970 World's Fair in Osaka, was in its original version created through bursts of acoustic feedback, exploring "the ever-changing relationship of 2 microphones to 37 loudspeakers in space" (CIE 1976a). In that version, two highly directional microphones were directed out towards a switchable network of speakers, and varying types of feedback resulted from their spatial relationship to various speakers being turned on and off. A second version of the piece, made at Mills College in Oakland CA in 1973, used microphone/loudspeaker combinations isolated in four separate chambers, with the addition of bandpass/bandreject filters controlling the character of feedback produced: sounds like "primordial beasts" (Tudor 1984). This was the approach taken for the Paris performance in 1976, with Linda Fisher as co-performer.

Tudor's newest work, *Pulsers*, pursued a compositional direction begun in the late 1960s with his chirping *Rainforest* oscillators, developed in 1972 with *Untitled*, and continued in 1975 with *Toneburst*. This was the use of unpredictable electronic feedback loops created by interconnecting complex networks of devices—primarily amplifiers of different types. These feedback pieces represented Tudor's second significant strand of compositional investigation in the early 1970s, paralleling the continuation of *Rainforest*. As the concepts behind *Rainforest* are reflected in a great deal of work created by members of Composers Inside Electronics, so it

is with Tudor's feedback pieces. Paul DeMarinis, whose soundmaking equipment for the Festival d'Automne *Rainforest* included a number of open circuits which could be connected in feedback loops with alligator clip leads (the hardware for a piece entitled *CKT*), says that at the time, "everybody who was playing around with circuits was realizing that there was no point defining inputs and outputs distinctly and packaging everything in boxes and all of that. I mean that was so much of the time and expense making something. People were just kind of building things" (DeMarinis 2001). Beyond the staccato electronic feedback bursts which defined *Pulsers*, an important feature of the piece was a recording of Takehisa Kosugi improvising on electric violin, providing a "natural kind of structure" to the piece (Tudor 1984).

John Driscoll noted that "With David I always felt that a piece was a way station on a whole series of ideas, and he really was almost dealing with the same ideas but there were variations that turned into pieces. Those rhythmic oscillators [for *Rainforest 1*] and such ended up later, you know, turning into *Pulsers* [...] and you know the *Microphone* piece was in some ways a very strong analog to what happens acoustically, in the same way as what *Rainforest* does" (Driscoll 2000a).

CIE: Logistics of touring

With the invitation to Paris came the new challenge of orchestrating the shipment of necessary equipment, including a large number of *Rainforest* objects, plus all the performers' hardware for performing *Rainforest* and the many other compositions programmed. As early as July 1976, Performing Artservices had identified the most cost-effective and simplest method of shipping: rental of an airfreight-ready container known as an "igloo", having 440 cubic feet of space in which to pack equipment (Performing Artservices 1976a). In October, an empty "igloo" was delivered to the Gate Hill Co-op where CIE had been rehearsing the

concert series, and it was packed with 37 fibreboard suitcases and boxes, totalling more than a ton of cargo.

[...] we ran through the majority of the pieces in this studio (those that were possible with the space limitations or technical needs). Since we were all involved in each others' works it took some time to get familiar with all the works. I was living there at the time, so I probably put a number of people up during the rehearsals. We then had a flat bed truck deliver an aluminum igloo container that fit in the belly of a 747. It was quite an elaborate process to pack it all up and get everybody initiated into the process of making equipment manifests. (Driscoll 2005b)

The making of a detailed equipment manifest fell to Phil Edelstein, who collected precise details from each performer as to their preferred *Rainforest* objects (see Figure 6-9), and the contents and valuation of their cases. From the final shipping manifest (Performing Artservices 1976a), organized by performer, we can get a picture of the complexity of the operation, and the diversity of instruments, devices and *Rainforest* objects which CIE packed for the trip. The list of hundreds of items includes numerous homemade synthesizer modules, some commercial synthesizer equipment, an erhu, a viola, an "Emenee Golden Pipe Organ", a "mini psaltery in case w/ tuning hammer", "assorted styrofoam balls", the *Pygmy Gamelan* circuits and their power supplies, many AM radio transmitters and receivers for *Catch Wave*, and "meat pounder, back scratcher, 4 boxes of musical accessories (small objects, beaters), bag of marbles, box of tiddly-winks, rubber squeegee" for Tudor's performance of the Richard Maxfield *Piano Concert*. Fisher, Viola, Driscoll and Kalve packed numerous tapes "pre-recorded for performance" for *Rainforest*.

Some loudspeaker-objects can be identified in the manifest, for instance Phil Edelstein's "wooden box (wine crate)", "bronze strip", and "wooden tray", John Driscoll's "(2) garden sprinklers (plastic)", Bill Viola's "Stainless steel can (instrument)" and "brass disc instrument", and, in a

BILL	①	SS gal drums	20kg
	②	small stainless steel can	4kg/14" H x 8" dia.
✓	③	flat circular brass w/hole	8" dia in ctr. 6 lbs.
	④	crumpled circuit drum	15 lbs 8 kg
	⑤	?	
PAUL			
	①	stainless steel bottle	5kg/14" x 8"
✓	②	metal ring	16" dia 1kg
	③		
MARTY	①	AIR VENT	16" H x 24" dia 10 lbs. 5kg
	②	see shell	
	③	cardboard cylinder	1' x 8" dia
✓	④	steel rods	5kg
	⑤	metal shelves	35cm h. x 24cm. 16 kilo
DAVID	①	steel triangle	5" x 5" x 5" 5kg
	②	iron hoop	135cm dia. 4kg 12k
	③	metal cross + springs	135cm x 135cm 3 kilo
	④	metal shield	1m x 1/2m 5 kilo
	⑤	small triangle	41cm x 41cm. 2 kilo
	⑥	aluminum plate	33cm sq. 2 kilo
	⑦	plastic wastebasket	1 1/2m x 75cm 1kg

Figure 6-9. One of three pages of notes by Phil Edelstein (Edelstein 1976c) listing preferred loudspeaker-objects for the Festival d'Automne 1976, as selected by Bill Viola, Paul DeMarinis, Martin Kalve and David Tudor.

"group" shipping crate, many more including "metal disc, 2 aluminum angles, 1 Honeywell tank quantity sensor, 1 steel cover with handle, 1 steel fan cover, 1 badminton racquet, Plastic float, 4 pieces steel tubing with fixtures, aluminum stock 10x12x3/4", 2 plastic hoses, 3 copper rods, 1 iron hoop, 2 wooden trays, 1 cast iron ring, wood box containing copper and plastic toilet floats and 1 wave-guide [...]", each item with a cash value for import/export and insurance purposes (total value of the freight shipment was given as US\$26,510.00, with the most expensive single items listed being Paul DeMarinis' homemade and Buchla synthesizers, each listed at around \$1200.00). Of particular interest is an early appearance in this list of some commercial "guitar pedal" type processors among David Tudor's equipment (Electro-Harmonix "Mole" bass booster and "Screaming Bird" treble booster circuits, and PAiA "Synthespin" Leslie speaker emulator); throughout the 1980s and 1990s, Tudor's use of commercial effects processors such as these became ever more prevalent.

Total expenses for the Paris trip included artists' fees of \$750 per person, plus \$500 per person as total *per diem* for the duration of the group's stay in Paris, intended to cover 14 days. This was the era of Frommer's *Europe on \$10 a Day*, and the performers' accommodation was covered by the Festival. Marsha Green of Artservices wrote to CIE members a month before the trip with a financial update, commenting "Looks like fat city to me..." (Performing Artservices 1976c).

The balance sheet prepared by Artservices, however, shows eight *per diems* but only seven artists' fees. It is possible that Tudor was paid through another channel for his role as programmer, rehearsal master, composer and performer, but on the face of it, it appears that he directed the budget to the benefit of his younger colleagues. This would fit with the

general perception among the CIE group, that Tudor intended CIE and *Rainforest* as

[...] the vehicle to get our work out, which I always greatly appreciated because he didn't have to do that [...] I think it was part of his plan to sort of say, here's some people doing some new stuff and take a listen. And [CIE] gave him an umbrella that was easy to sell to people: "Well, you get my stuff and..." That's really how the door got open for us. Those people having to hear and come to grips to our works. And then [...] you would know the people who ran the festivals the next time and if you wanted to do something [...] it would be an easy phone call or letter. And that made a big difference, start getting introduced to all these major festivals and curators and you know, orchestrators. And I think that was very deliberate on his part. (Driscoll 2002)

Paris postscript

Rainforest's part of CIE's week-long programme for the Festival d'Automne was all too brief, given the amount of expense and energy necessary to make it possible. Not only did the Festival go to the trouble to bring the musicians and all their technology, including numerous *Rainforest* loudspeaker-objects, there was also the problem of the Musée Galliera, which did not have a lighting grid or any other convenient means of hanging the objects. At great trouble and cost, a means of suspending them was created, which turned out to have sonic implications for Tudor's later solo performance of *Pulsers*:

[...] it was a horrendous job hanging it in that museum because it had a plaster ceiling and you couldn't anchor anything into it [...] they had to bring a welder in and weld a whole grid that we could hang things from, which we were really opposed to because it looked hideous. It was a square steel tube grid in the main hall and we were allowed to hang things from that. It turned out to be interesting though when David did a performance of *Pulsers* where he transduced that grid and used it as a signal modifier in *Pulsers*. That was the kind of thing that Tudor always did—that approach to the found object, that unavoidable compromise or something would be turned in as a new starting point always, which I think has to do with the [...] very real commitment to that process of starting anew

in each moment, like performing those immensely complicated pieces and being in this eternal present where each place is a new starting point. I think that was very much part of his style. (DeMarinis 2001)

After all this, the piece was performed only on October 20, the first day of CIE's series. Fortunately, an offer was made to host *Rainforest* in a second venue. According to Paul DeMarinis, at the end of the Musée Galliera series "consensus was that *Rainforest* hadn't gotten enough exposure", and Bénédicte Pesle (of Artservice International, which managed Merce Cunningham's company in Europe) arranged to have it installed for an additional five days, between November 2 and 6 at l'Éspace Pierre Cardin, a gallery opened by the couturier in 1970. Composers Inside Electronics, minus Linda Fisher and Phil Edelstein who were unable to remain for the extended time, performed *Rainforest* for a total of at least 25 further hours in the new gallery.

DeMarinis recalls, "It was much more amenable space for doing the piece. We didn't have to do the grid [for suspending objects]. It was kind of impromptu. Everybody was over there and had time on their hands, which is something nobody has anymore. Nobody had jobs or obligations of any kind, nobody had email or contact with home, so we just kind of went out there and were there 6 or 7 weeks altogether. It was good, and a good time to make other connections". DeMarinis himself found another venue for *Pygmy Gamelan* at Galerie Shandar, where the piece was shown for several months (DeMarinis 2001).

The extended presentation of *Rainforest* invited the involvement of other performers who were able to drop by: singer Joan La Barbara was one such guest (see Figure 6-10), and her experimentation with Tudor recalls descriptions of the voice-based *Rainforest 2*.

David thought it would be intriguing to have me sing live in the space, using a microphone so that my voice would be audible only as it resonated in the various objects. [...] I listened to each of the

objects and how they reacted to the various sounds that were being fed into them prior to putting my vocal sounds into the environment. David explained to me how the voice would be captured and sent to various objects. I am sure he thought of it as a sound source, like any other sound source, and played with it accordingly. I did a range of vocal sounds, harmonics and overtone focusing, isolated resonance investigations, some ululations and multiphonics, blending with the other sounds in the rainforest. (La Barbara 2005)

Another performer who sat in with the group was composer and hardware hacker Nicolas Collins, who had met and worked with Tudor as a student at Wesleyan University, as early as 1973. Collins recalls using the existing setup of Paul DeMarinis on his visit; he was later to join CIE for further *Rainforests*, and work as an assistant to Tudor on other projects in the early 1980s (Collins 2006).



Figure 6-10. *Rainforest 4* as installed at l'Éspace Pierre Cardin, Paris, November 2-6 1976. David Tudor, foreground, and Joan La Barbara seated with microphone. Martin Kalve is seated at the table behind Tudor. Photographer unknown; photograph provided by Joan La Barbara.

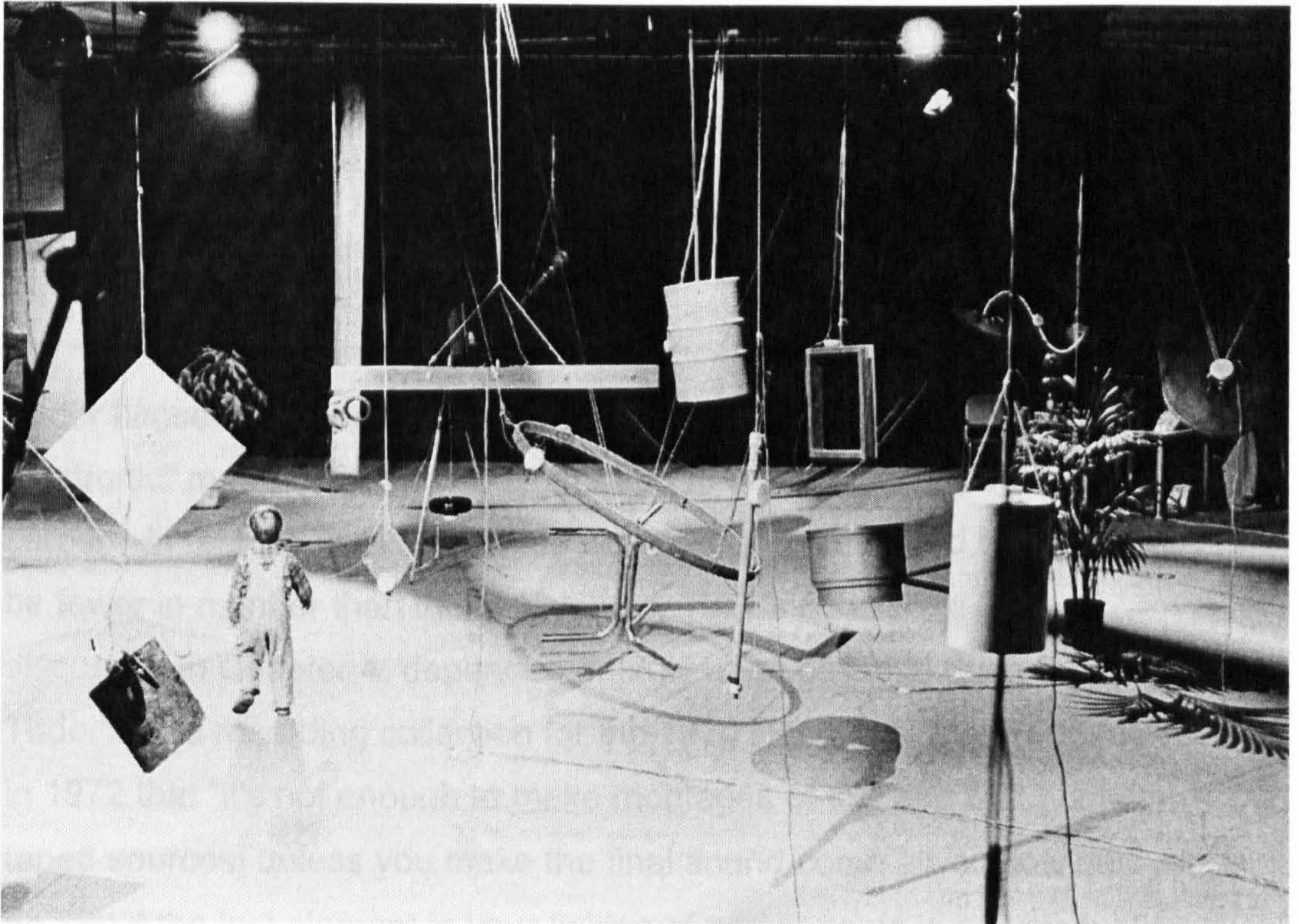
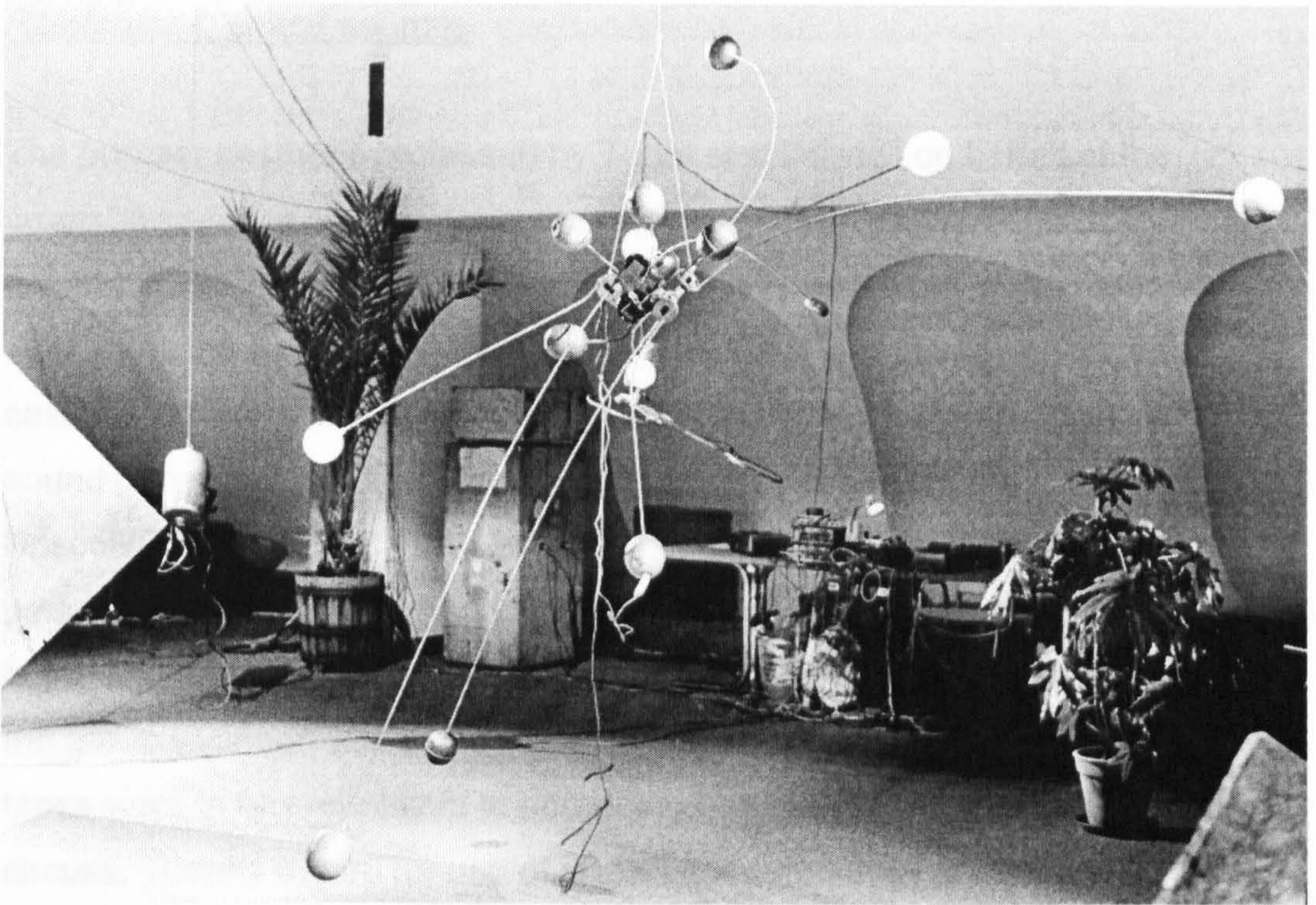

Figure 6-11. *Rainforest 4* as installed at l'Éspace Pierre Cardin, Paris, November 2-6 1976. Photographs by Ralph Jones.

Rainforest 4: sound sources

The primary aesthetic professed by Tudor and Driscoll on behalf of the group, through its name Composers Inside Electronics, was one of "live electronic" sound production. This was certainly borne out in the new works created by CIE members, which may have included prerecorded cassette tapes as one of many elements, but usually focused either on sound generation via homemade electronic devices (as in the Driscoll/Edelstein/DeMarinis/Jones works discussed above) or live performance exploration of acoustic phenomena via electronic means (as in the Kalve/Fisher/Viola pieces). *Rainforest 4*, the piece which brought the group together, however, was one CIE arena where prerecorded tapes were in fact employed in equal or greater measure than "live" circuits. Tudor's regard for use of prerecorded materials is clearly stated in this 1985 interview:

I don't like electronics when they're used simply to reproduce something, except sometimes in environmental situations, where music is part of it, that seems acceptable, especially when it's presented in a lively way. (Tudor and Cage 1985)

Tudor himself often used cassette tapes as a "lively" element of his "live electronic" music from the 1970s through to the end of his performing career—in fact the works which do not include prerecorded materials may be fewer in number than those which do. 1972's *Rainforest 3*, as discussed in Chapter 4, depended entirely upon cassette dubs from Tudor's field recording collection for the 1970 Pepsi Pavilion. Tudor wrote in 1972 that "it's not enough to make montages of this and that [various taped sources] unless you make the final sound come alive. How can you do that if the last element in your linking of components is a reproduction medium?" (Tudor 1972c). By this Tudor meant a conventional paper-cone loudspeaker as opposed to his idiosyncratic loudspeaker-objects, which by their very nature could make the sound "come alive".

Pulsers, as described above, incorporated a recording of a violin improvisation in lieu of the presence of a live musician. *Dialects* (1984) prominently features more of the Pepsi tape library. *9 Lines Reflected* (1986) and *Virtual Focus* (1990) both use source recordings made by Tudor. In many cases, the tapes as "source material" are never heard directly but are instead used to drive other processes, or are significantly altered by passing through numerous devices which change their character.

In 1978, as part of a CIE residency at Media Study / Buffalo, Tudor offered a lecture-demonstration entitled "Altering signal sources in real time", with the description "Transformations by electronic and non-electronic means; speech and other sound simulations; or, how to make the ordinary extraordinary" (Media Study / Buffalo 1978).

Explaining in detail the techniques fundamental to his work, Tudor traced the historical development of this personal style of electronic music-making, and argued for "output processing", the electronic enhancement of basic sound sources, as a means of heightening the aesthetic quality of musical material. Introducing "a sound that I hate", a recording of a grasshopper chewing a leaf, Tudor demonstrated how by output processing techniques, that sound could be transformed into a striking musical event. (Media Study / Buffalo 1979)

The transformation of prerecorded sound through *Rainforest's* transduced objects can also be a radical transformation, and so the extensive use of such material, in a context where there are many sound sources mingled in a dense sonic "forest", and where taped sources are likely to be swapped in and out improvisationally, is not at odds with the professed philosophy of the group. Bill Viola said,

[...] it's something Tudor did stress, that it was really when the sound going in was not the sound coming out, when the sound coming out was really transformed, that's what you were sort of searching for. So you have this array of material, and it was guiding you beyond Tudor, when the objects resonated, and added all the resonant frequencies, some of which weren't even in the original

sound, they were like multiples and harmonics and things, and you got back this ringing from, like, these frogs that went in, then that was it and you went to another source and experimented with that. And so in a way it was telling you that it wanted to transform the sound—like there was a direction mechanically contained within the materials themselves that was guiding us also. (Viola 2000)

If we look again at the score diagram for *Rainforest 4*, below, it is also clear that equalisation is prominently featured as a means of adjusting the character of whichever signal source might be chosen, and that is also a potentially radical (and performative) action upon prerecorded sources.

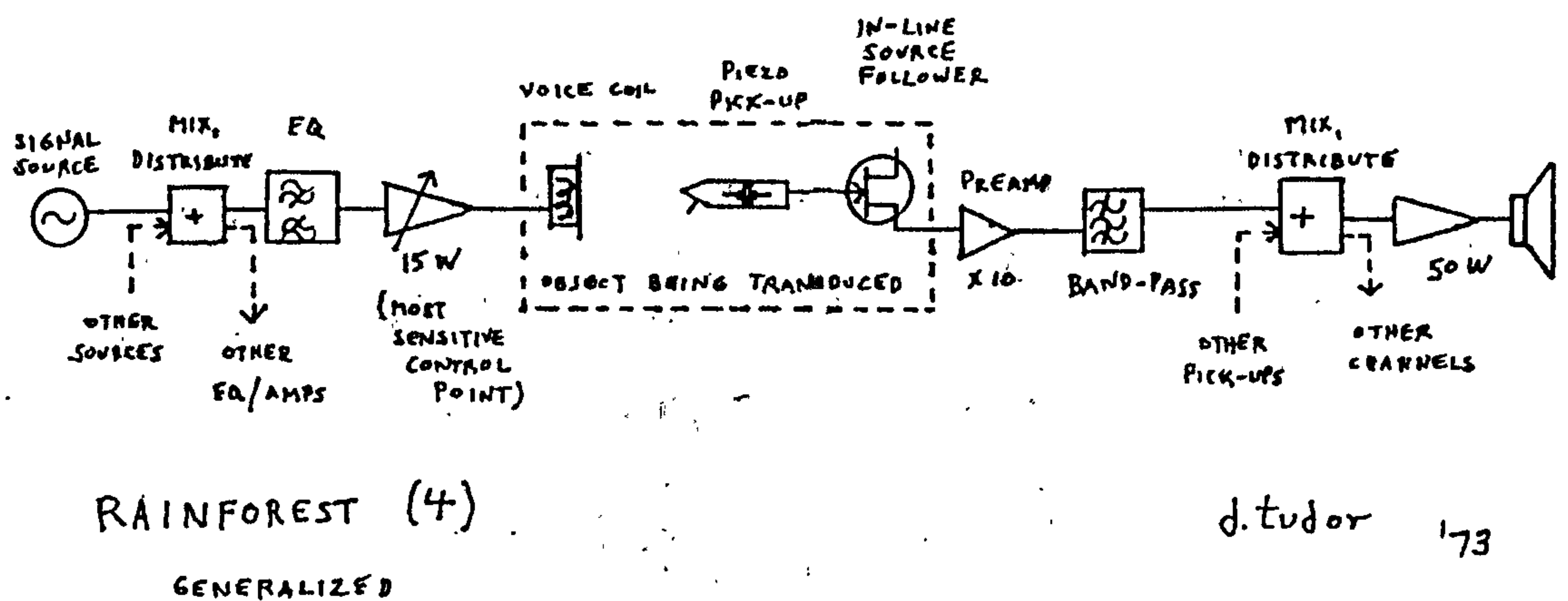

Figure 6-12. *Rainforest 4* generalized score diagram (Tudor, 1973a).

Linda Fisher has stated that her reason for primarily using field recording materials for *Rainforest* was simply because they were richer than the electronic sounds at her disposal:

I would say probably 75% were tape-based, because I loved acoustic sounds and I would go out and record. And I lived in Ithaca at the time [...] and I would go and sit by a frog pond for hours at night and get source material. You know, birds... I recorded all sorts of things. And swings—contact microphones on swings. And then I would use my synthesizers to create, you know, more electronic kinds of sound... oscillators. And I had built a couple of little oscillators, little Radio Shack things that I used, but I really preferred, I think, sound sources that were around me for the objects. Somehow they were richer. They may not have been able

to focus in quite as finely, but there was something about them that was richer to me. (Fisher 2003)

But the primary reason for CIE's substantial reliance upon recordings as source material for *Rainforest 4* may be, perhaps, ultimately a question of convenience. John Driscoll made a striking comment on this topic, describing a gradual migration towards prerecorded sounds:

Phil early on generated a lot more material [with "live" circuits] than most of the others, and Ralph did some generation, and I did because I had a bank of oscillators I even brought to Chocorua. But slowly but surely you found, oh man, I'm just schlepping this rack of stuff, and why not just record it ahead of time and have it on the tape? Because there was nothing truly gained out of the live performance, because of the serendipity between the other people, that you couldn't really do with tape, it wasn't that time-critical. In fact what it did then is give you a library of source material that you could easily slap in and out, versus being stuck in a patch and trying to find another patch quickly enough to shift gears. So I think slowly but surely the live part of it just ebbed away. Though Phil persisted. Phil always enjoyed one or two live components. (Driscoll 2000a)

As with *Rainforest 3*, the broad acceptance of taped sounds in performance of *Rainforest 4* invited the use of many different field recordings. Driscoll says that he used "a ton of them. Animal sounds. Oh, I had recordings of heating systems banging and clanging away, I mean the library of materials that I used would be huge in terms of the variety of material. [...] It's very diverse, [the group's total collection of tapes] might be a hundred-some cassettes" (Driscoll 2000a).

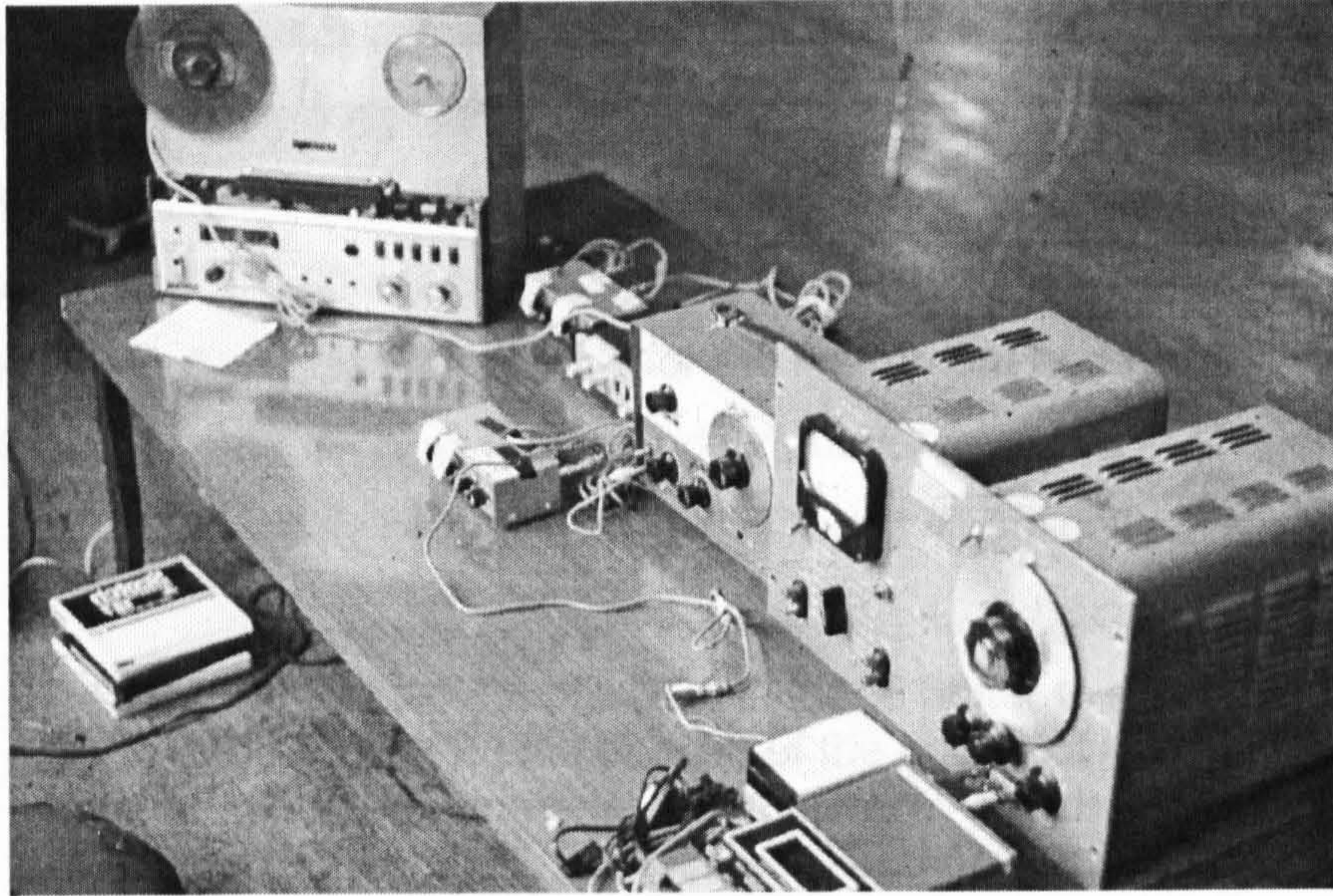

Figure 6-13. John Driscoll's table for performance of *Rainforest 4* at Mills College, April 9 1975. Note combination of reel-to-reel and cassette tape decks and function generators. Photograph by John Driscoll.



Figure 6-14. David Tudor's (foreground) and John Driscoll's tables for performance of *Rainforest 4* at the Institute of Contemporary Art, Philadelphia PA, April 1979. Note presence of at least four cassette tape decks on Tudor's table, along with boxes of cassette tapes. Photographer unknown, obtained from John Driscoll.

The virtues of the stereo compact cassette format went beyond ease of transportation; one cassette could be programmed with different source material on its left and right channels, allowing two loudspeaker-objects to be played from a single tape recorder. In Tudor's ideal, "you should do something that you do intentionally for the instrument and not just think that the instrument is going to respond, whatever you give it" (Tudor 1995) but in the reality of improvising *Rainforest 4*, Driscoll says

[...] Some of the sound material was tuned better to some of the objects and some of them because of the nature of making that much [source sound] material, I can honestly say that they weren't always true to the object. Sometimes it was convenient to have that source material, or somebody liked that source material. But eventually what you found was, like I had a whole series of frog recordings and it wasn't so much that I specifically tuned those to an object as I found an object that responded nicely to that range. And I think that was a difference, was that we used a lot of acoustically recorded material and in that regard it isn't like taking an object [...] and generating material for it. It's more like, well, what material would work best in what object? And that sort of got down to a point where an object would have a set of source material for a performance rather than, this source material could go through [only] this object [...] (Driscoll 2000a)

Driscoll's collection of *Rainforest* source cassettes, currently dubbed to audio CD, represents a wide spectrum of material. A great deal of it is made up of field recordings, made with air or contact microphones in a variety of locations; some are strictly electronic sounds; some are electronic sounds modulated by acoustic sounds. The list below describes twelve of Driscoll's source tapes (please refer also to excerpts on the audio CD accompanying this thesis), their left and right channel programming, and notes in some cases on their associated *Rainforest 4* objects. This documentation was made in 2002 and shows some more recent additions to the collection of recordings (the video game sounds, for instance).

<u>TAPE LEFT AND RIGHT</u>	<u>ASSOCIATED OBJECT(S)</u>
1 L: pulse oscillator, no processing R: pulse oscillator, transduced through bamboo rod	toilet floats, wagon wheel rim, plastic bottle garden sprinkler
2 L: motor with speed control (recorded via contact mic) R: chirping oscillator	toilet floats, wagon wheel rim, plastic bottle garden sprinkler
3 L: mockingbird, processed R: mockingbird, processed (rec. in Washington DC)	
4 L: blowtorch R: motor of heating system, recorded by contact mic on radiator	mica sheet
5 L: waterfall, rec. through wagon wheel rim R: paddleball court, Salt Lake City	wagon wheel rim, toilet floats mica sheet
6 L: typewriter + oscillator loops R: motor + arcade tank game	
7 L: oscillator chirps R: arcade tank game + organ pipe drones	hard plastic objects, toilet floats wagon wheel rim
8 L: <i>Earthing</i> source material + pulse generator + organ pipe drones + ultrasonics R: ultrasonics	combination of sources designed to activate multiple resonant frequencies of one object
9 L: rain in alleyway, Rome R: rain on metal sheet, rec. with contact mic	toilet floats hard plastic objects, toilet floats
10 L: mockingbird R: oscillator loops	
11 L: rain R: rain	
12 L: oscillator modulated by birdsong R: spring peepers	

Figure 6-15. Partial list of John Driscoll's prerecorded materials for performance of *Rainforest 4*. Excerpts included on audio CD accompanying this thesis.

Three comments can be made about the above list. First, there appears to be a great deal of focus put on sounds which by their nature would be useful with a multitude of objects: namely, broad-band sounds which contain energy at many frequencies. This would certainly include the rain, blowtorch, pulse oscillator, and typewriter recordings. Second, the origin of the recordings—whether they originate with circuits or with birds—is, in the end, oddly irrelevant to the overall quality of the *Rainforest* installation. When transduced through an object, "the electronic sounds may even sound more like natural sounds than the natural recordings" (Jones 2001), and it is also true that some "natural" sounds may, on being transduced, take on an "electronic" character.

The third observation which might be made is that many of the recordings are associated with specific places and times; the act of continuously recording new material while traveling is the creation of a sonic history of one's travels: stories are attached to sounds the way the sounds may be associated with specific objects. One story which I was told on several occasions by different CIE members involved Bill Viola's attempt to record whalesong while on a whale-watching boat trip in Baja, CA. In Ralph Jones' version:

He had acquired a hydrophone. And this was around the time that the humpback whale recording came out on LP, and everybody was really into that, and with great reason, they were wonderful sounds and beautiful songs, and he wanted to make a whale recording, and so he went out on this fishing boat turned whale watching cruise boat in Baja, and they encountered a pod of whales, hit "record" and promptly became seasick. And grey whales actually don't sing. So all he had was the noise of the ocean, which is basically like a hiss, with some clicks and pops, with this kind of "ploop, ploop, ploop" as he was vomiting over the side of the boat. [laughs] That was all he got! (Jones 2001)

This story, associated with a field recording expedition, has become part of the broader *Rainforest* story; it is a tale which has the sense of "belonging" to any member of CIE, although it was experienced by Viola. Stories are strongly connected to such sounds, in a way which perhaps

they could not be connected to the live output of sonic circuitry. John Driscoll said of his tape collection that there were memories attached to "just about every one of them" (Driscoll 2002). Circuits, especially if one has invested time and energy in their development, may over time "more & more reveal their personalities" as Tudor put it (Tudor 1976b) —the *Pygmy Gamelan* might be identified as a piece built around "charismatic" circuits, for instance—but although stories might be hung on the hardware itself, the output of that hardware seems less likely to be memorialized through story.

Although prerecorded material was prevalent in *Rainforest 4*, and some CIE players made almost exclusive use of tapes, live electronics retained a foothold, and certain other musicians had a very strong preference for the live production of sound. Paul DeMarinis recalled that in his 1976 setup for *Rainforest 4*,

I never used microphone-recorded sounds [and] the idea of recording electronic sounds to me, at that point, seemed oxymoronic. They could be created fresh. Why would you have tinned ones, other than for the practicality of leaving it or having more objects than you had circuits? Even then I didn't like it, but I tinkered with some of those voltage [controlled] cassette players [...] The original Norelco one [...] had this feature that you could make it voltage controlled and control the external signal and the speed of the tape. So I think I used that so that the tapes wouldn't play back the same way twice. I didn't like the idea of recording very much, at that point. I just wasn't interested in it. I wasn't interested in hi-fi. I think at that point I disavowed any relation to recording or hi-fi or any of those things. It was definitely all low-fi, real time.

Ultimately, DeMarinis says, "It's the objects that really make it and there's a certain kind of sounding object. People would try things out and [they] would get quickly retired. Things that would look good but wouldn't sound good" (DeMarinis 2001). The acoustic presence of the sounding objects was the key element of a successful performance; the source of their sounds was of relatively little importance. *Rainforest* contrasts in this regard with the other works created and performed by CIE, which

although they might involve prerecorded material to a small degree, were invariably focused on a stricter "live electronic" aesthetic, as set out by David Tudor in his "mission statement" for the Paris performances in 1976, as quoted earlier in this chapter (Tudor 1976b).

More important than the source of the sounds in *Rainforest* was their character. Whether produced by live circuits, recordings of the output of circuits, or environmental recordings, what seems critical is their semi-repetitive, intermittent quality, described by DeMarinis as "periodicity with interruption", or "semi-chaotic" (DeMarinis, 2001). Sounds with these qualities can comfortably coexist in a room where as many as 40 may be playing at any one time; a wide range of objects, of different materials and varying sizes, helps by ensuring that the sound materials are also differentiated in frequency. Because each loudspeaker-object favours only specific frequency regions, when many are combined in a space there tends not to be a great deal of overlap (this was noted by Tom Johnson in his review of *Rainforest's* debut performance (Johnson 2002)). John Driscoll has remarked on the morphology of a *Rainforest* performance, noting the conjunction of "large shifting sound characters that evolve over extended periods, interspersed with short-duration local sound events unique to one object" . The result is "an improvisational coordination of the sound materials, but one that has become extremely familiar and ingrained in the performers" (Driscoll and Rogalsky 2004). Some of the "ingrained" nature of the performers' relationship to CIE and *Rainforest* has the quality of ritual, where ritual is loosely defined as habitual or "traditional" activities which emerge to support the group's identity.

Phil Edelstein explained the development of the complex social fabric of CIE through an interesting metaphor, that of the need to develop life in the context of a seemingly barren technological landscape: "How do you survive in technology space? How do you find life-giving, sustaining elements—that sort of goes back to Death Valley, like how do you live in the desert? You know, technology is kind of a desert. How do you live in

the desert? You find wonderful ways of living in the desert. It's really a good spiritual space. Drinking cactus juices is not really a bad way of dealing with deserts, is it?" Edelstein thought of the process of repeatedly presenting *Rainforest* as being

[...] more than just little rituals. It became more or less apparent that performance *is* ritual. [...] the interaction between spirit and ritual and devotion—I'll use that better than religion, in a way—made a lot of sense. [...] I would say the repetitive aspect [came first] and then when it became so internalized that it became a ritual. (Edelstein 2002)

Sonic and social rituals in CIE

The dynamics of Composers Inside Electronics, with Tudor as the "spiritual center and the artistic center" (Jones 2001), included personal and group rituals which developed over time and became expected parts of a performance. Linda Fisher says of these traditions, "They're very strong—very, very strong", and reinforce the aspect of CIE as family: "[...] a real family... I mean, I feel so close to all those people [...] because we've been *Rainforesters*. I mean, there's just some kind of bond that's developed that just defies analysis almost, to me" (Fisher 2003).

Sonically, the connection between certain sounds and objects is strong. While new *Rainforest* objects were being constantly introduced from performance to performance, the regular reappearance of certain items could in itself be considered ritualistic. Among the original 1973 objects, Tudor's large wagon wheel rim became somewhat iconic and was put into storage between *Rainforests*. A number of other objects from the first performance have survived in this way as well, and are greeted as old friends by the original CIE members. One item in particular, John Driscoll's toilet float sculpture, has appeared in every installation of *Rainforest* with which Driscoll has been involved; the sculpture is recreated each time, however, growing more and more elaborate, with

different numbers of floats dangling off a central mounting point, attached to the ends of metal rods which convey to them the vibrations of one or more transducers (see Figure 6-16). Another object, the oil barrel, regularly reappeared, suspended with open end facing down so that a listener could stand up inside it; Bill Viola was its usual "owner".

Although John Driscoll writes that "There are no coordinated starting points and ending points to the work other than the scheduled durations of the performances" (mirroring the Cage/Cunningham paradigm of collaboration), he also states that the group's strategies in improvisation became familiar over time. Specific familiar combinations would present themselves on a regular basis: "There were classic little riffs with certain objects that we just came to be very fond of. And that probably influenced the piece more than it should have [...] Billy [Bill Viola] had these monkeys that he would put through the fifty-gallon drum, and it got to the point where you would always hear the monkeys in the fifty-gallon drum [...] I mean, you fall into these little habits, and it had as much to do with that as anything". The use of cassettes was also a restricting factor: "you'd always try to double up on cassette, so which sounds got put on the left channel, which on the right, influenced how you used them" (Driscoll 2002).

Driscoll also observed that

[...] it wouldn't necessarily be obvious to someone else, but the way people set up the tables was just absolutely ritualized. In other words, which equipment would go off on the left wing, which was central, and that would change if there was some hot new thing you were using, that would typically become more centred and the older

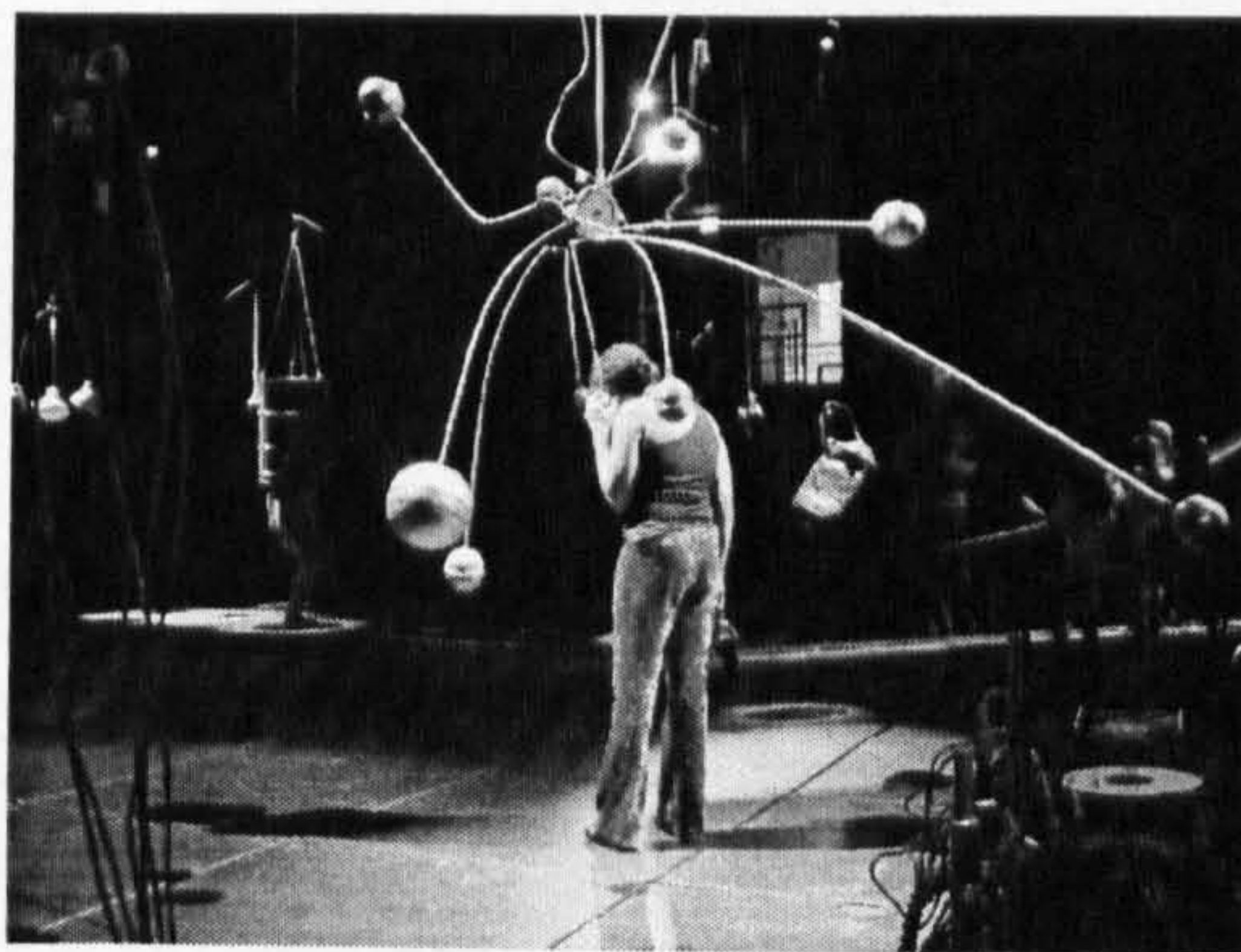
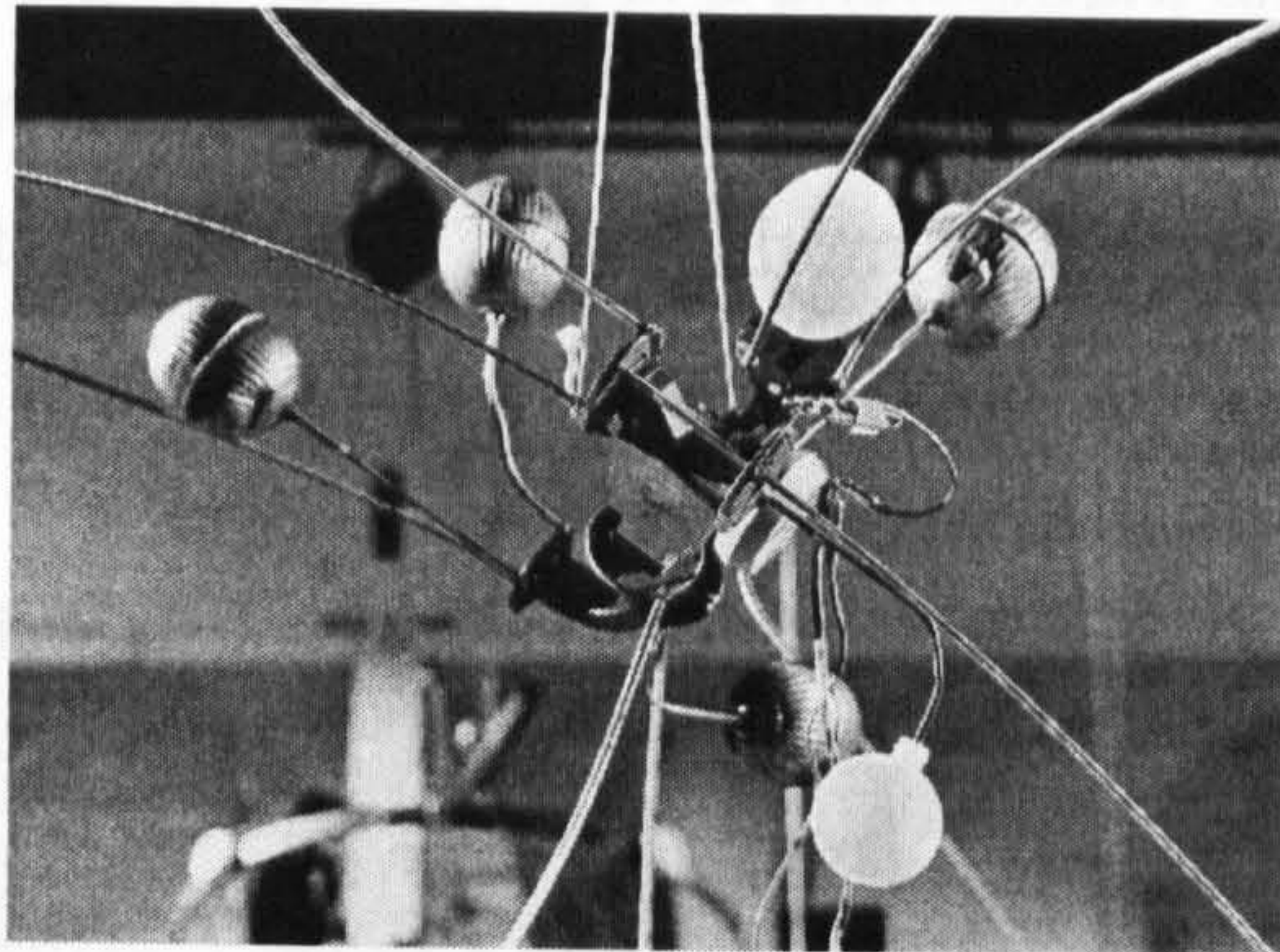
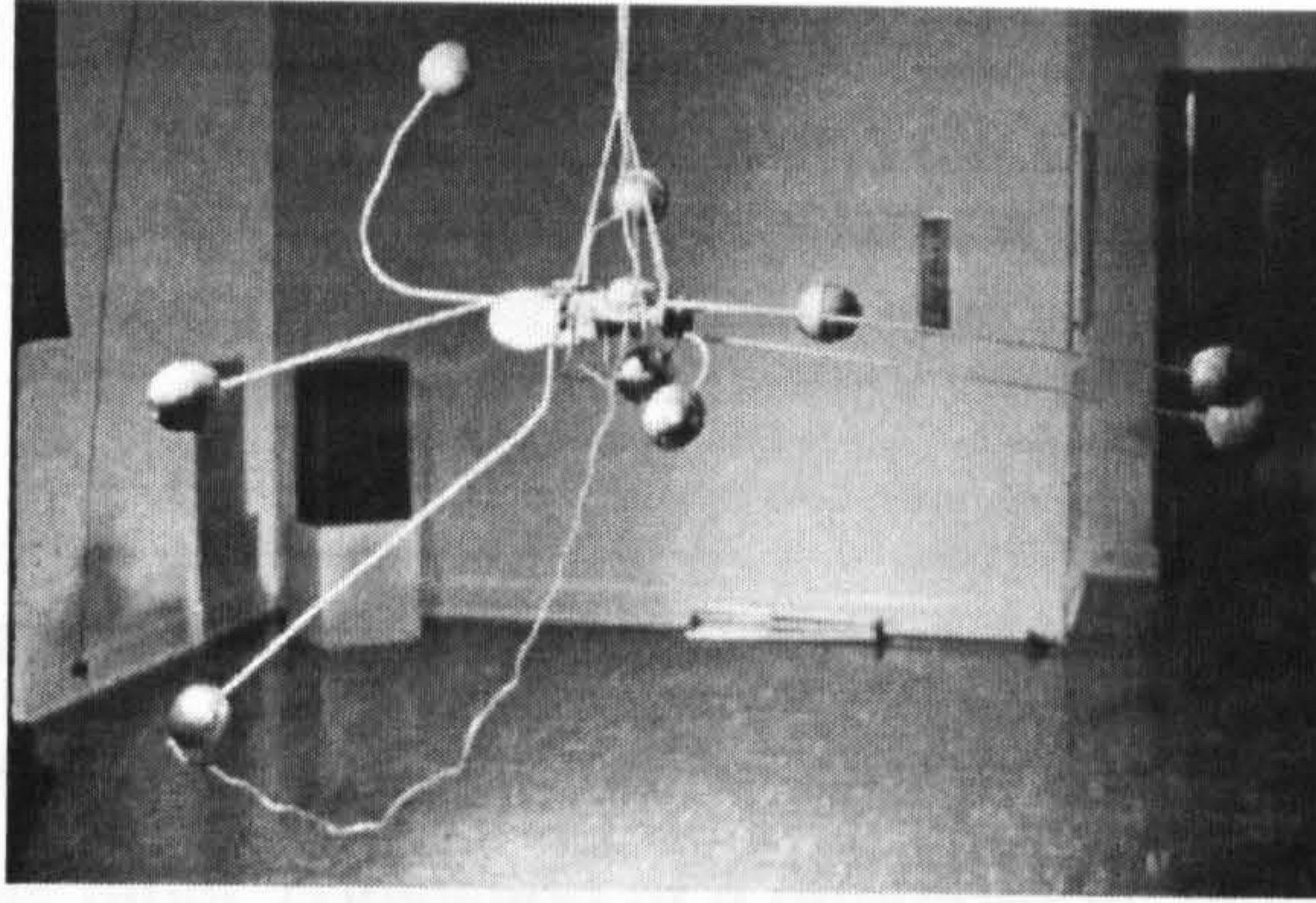

Figure 6-16. Four incarnations of John Driscoll's toilet float sculpture. Chronologically, from top: de Saisset Art Gallery, Santa Clara CA 1975; l'Éspace Pierre Cardin, Paris 1976; The Kitchen, New York City 1977 (shown with Billy Klüver); California Institute of the Arts, Valencia CA, May 2001 (with unidentified listener). Top three photographs by John Driscoll; bottom by unknown photographer.

stuff would move off to the periphery, you know. I was always fascinated by the sculptural aspect of how people set up their tables, you know, what stuff got stacked, what stuff got laid out. Everybody was very different in that regard.

Bill Viola has commented on some *Rainforest 4* performance traditions which he personally maintained, particularly the act of creating a sort of small shrine at his table, consisting of a photograph, along with an incense holder and an unlit stick of incense. Frequently, he said, somebody would bring flowers and lay them down on top of each musician's mixer (Viola, 2000).



Figure 6-17. Bill Viola in performance of *Rainforest 4*, Institute of Contemporary Art, Philadelphia PA, April 1979. Note bouquet of flowers in tequila bottle. Photo courtesy ICA Philadelphia.

Ralph Jones says he "never took a ritualistic approach to it, I never had a favourite sound to end the piece or start the piece or stuff like that, I just kind of did it", but he also recalls that David Tudor had "particular sounds for that hoop [the large wagon wheel rim] that to me became like one of the hallmark sounds of *Rainforest*. There was a wonderful multiple sliding sinewave thing [...] it became like a signature sound of *Rainforest*. As soon as I heard that sound in the hoop, that was it. We were cooking". And if this sound defined the piece as well underway, Jones recalled without elaboration that Tudor also had "specific sounds that he would use at the end of a performance" (Jones 2001).

When I asked Jones whether he could identify any other rituals or habitual behaviours which grew up with the piece, he replied "Drinking tequila was definitely one of them. I mean, I'm not certain I've ever been involved in a *Rainforest* where there wasn't a bottle. Early on it just became part of the thing. [...] David was a real connoisseur of alcohols. And that actually was a major part of the whole sensual experience. I mean, we would blow into Linz and immediately search out the most *recherché* eau de vie, you know. And that was certainly one of the rituals" (Jones 2001). Connections between *Rainforest 4* and the consumption of alcohol have been mentioned previously in this thesis; Linda Fisher's recollection of Tudor's paternal "ritual of ablutions"—the pouring of tequila shots at the outset of a performance—is most striking (Fisher 2003).

Like the other CIE members interviewed, Bill Viola (2001) recalled the importance of alcoholic beverages in the social fabric of the group, and the imitative tradition which grew up of the performers' small cups for drinking tequila, and bottles kept in the "proverbial paper bag" under the players' tables, due to the fact that the venues where they performed usually frowned on drinking. The consumption of tequila was part of the peripatetic aspect of *Rainforest 4* performance, which involved much socializing amongst the musicians (Viola, 2000). The duration of the performances, sometimes as long as six hours, allowed them to become,

in the memories of many performers, relaxed social occasions: John Driscoll has emphasized this aspect of *Rainforest*, describing how he might set up a particular collection of sounds playing through his objects, and then go visiting other players; have a drink and a chat, listen to how his sounds were working in the overall context, and then perhaps drift back to his own table to make changes (Driscoll 2002).

Paul DeMarinis spoke of the

[...] influence David's drinking really had on all of us. It was part of the very acute, but wordless state of awareness of sound and moment, that you could drink and perform. [...] grappa was more often the celebratory liquor of choice for special moments, beginnings, endings and so forth. [And] there would always be the thing of going out after performances with David. In Paris, we went to a lot of fancy restaurants and there would be special things to drink. [...] I think you couldn't have been in that group [...] without drinking in that kind of way, [...] drinking that kind of exotica (DeMarinis, 2001).

The reference to "David's drinking" requires acknowledgement that Tudor did, from at least the mid-1960s and into the 1990s, consume alcohol with a regularity that would identify him as an alcoholic (Rigg 2002). In my interviews and conversations with his colleagues, the topic of Tudor's "medicine man" was brought up numerous times: a combination of unknown herbs steeping in vodka, in a baby bottle which traveled with him. "He was very secretive about it", said DeMarinis (2001). Tudor, along with his interest in Anthroposophy, was also a follower of naturopathic medicine, and it has been assumed by some CIE members that his herbal infusion was related to that practice, if only as a form of justification for continuous "medicinal" sipping (Fisher 2003). Phil Edelstein says, "I have a somewhat more critical view of it now than I did then. In retrospect, it wasn't some quaint little affectation, it was a manifestation of someone with a drinking problem—a well-controlled drinking problem, but someone with a drinking problem. And he used it as a way of starting drinking early in the day and going till late in the night" (Edelstein 2002).

DeMarinis says "I don't remember anybody ever getting falling down or becoming incoherent or unruly or anything. But there were long recoveries in the morning and that to me is the kind of proof of the syndrome, rather than any antisocial or asocial behavior. I take it much more on a neurological level as an indication of what I'd call alcoholism". The pattern of alcohol consumption as part of CIE performances has changed over time; since *Rainforest 4* performances resumed after Tudor's death in 1996 (following a long hiatus beginning in 1982), DeMarinis notes that while tequila and grappa are still present, they are imbibed "ceremonially" in comparison with quantities consumed in earlier years:

Rainforest had enough grace in it that even an incompetent like myself could imbibe a fair amount of alcohol and still do a passable performance. And David's virtuosity was such that probably it was enhanced by the alcohol. David's drinking now looks really pathetic because of the effect it had on his body and his later life and contributed largely to his present absence. But everybody took it up, and it became part of the ritual—one that gladly has disappeared. Other than specific instances of people, I think that the drinking that I've seen in *Rainforest*—the Lincoln Center gigs [in 1998]—has been just kind of ceremonial. (DeMarinis 2001)

"There's lots of fond memories of good grappa, in Linz", says Phil Edelstein. "We did *Ars Electronica* [1980, a CIE engagement which did not include a performance of *Rainforest 4*] and they had these horrible little rooms at the dormitories [...] but they had some great *eau de vie*. I don't know that it shaped much. Rather, I think that it limited things [...] Would the music have been better if we didn't drink as much? That's another way of looking at it. I almost think that, a little bit" (Edelstein 2002).

Gender politics and CIE

Although *Rainforest 4* began with a workshop which had an approximately even balance of male and female participants, the core group which continued it and formed Composers Inside Electronics was indeed predominately male; Linda Fisher was the sole female member of the ensemble, and her participation while Tudor was alive was restricted to ten performances out of 28, all between 1974 and 1976. Some women besides Fisher were involved in isolated *Rainforest 4* performances: Susan Palmer and Ritty Burchfield were part of the Chocorua workshop; Anne Sandifur and Virginia Quesada, who were also at the workshop, joined in the April 1975 *Rainforest* at Mills College; Cynthia Black, artist and collaborator with Phil Edelstein, participated in a major 1982 installation at the Stedelijk Museum in Amsterdam—the last before the long hiatus of *Rainforest 4* and CIE until 1995.

In discussing the fact that Fisher was the only female member of the group, Paul DeMarinis suggested "Well, it was pretty much a guy thing...It was the 1970s. Womens' issues were just beginning to be felt". He commented on the complexities of gender identity and performance, and noted distinctions between those in the group who "were really thinking about feelings" (Fisher and Viola) while the rest spent more time "thinking about gear" (DeMarinis, 2001). Viola acknowledged that any "male bonding" aspects of CIE came about primarily through fascination with electronics, and building circuits, and stated that Fisher "had a hard time" with that (Viola 2001b).

Ralph Jones' recollections of CIE's dynamics belie the gender-related matters which clearly affected the group in the mid-1970s, and which may for the most part have gone unnoticed or unremarked by most of its members at the time as well: "We were largely male. I don't know exactly why that is, it may [have been] a reflection of the times. I wouldn't say that there were any gender issues among us" (Jones 2001). Phil Edelstein similarly stated that "it's really not obvious to me" that there was any

gender politics in the group, but at the same time explained the lack of continuing female *Rainforesters* as due to the fact that "They weren't getting much out of it. In a way, I don't think it was interesting to them. I don't think there's a lot of sustenance there. [... *Rainforest* has ...] an aspect of it that is really gearhead" (Edelstein 2002).

In a 1979 letter to Tudor, Linda Fisher expressed frustration with this "gearhead" focus, which had the effect of drowning out sonic interests which she made attempts to explore as part of CIE:

[...] I felt an underlying frustration while feeling simultaneously euphoric about what "RAINFOREST" was doing to my life and sense of self. [...] I felt isolated as a woman in the group, and I felt anxious because I wasn't thinking in terms of large-scale constructions or innovative circuitry. I was pre-occupied, as I am now, with the software, the energies - things that have less to show for themselves in tangible ways. For the most part, I think you appreciated and supported this, but you were involved from not only this point, but one in which the technology was sophisticated, whereas sometimes I felt some of the others were pre-occupied with the hardware and rarely considered the inner implications. I guess I've felt a lot of frustration about this over the years. "RAINFOREST" uncovered various energies in me that I wanted to explore - often extremely subtle, often delicate, involving "space" both physical and psychic; the intent was not toward prettiness or softness, necessarily but subject to dynamics (not in terms of volume) and possible kinetic sound relationships between objects. I was working on these ideas although the effect was usually lost. (Fisher, 1979)

Another letter to Tudor the following year seems specifically to address a query from him regarding her involvement in (or her absence from) CIE performances, and clarifies some of the musical differences which Fisher felt kept her from fully participating in CIE.

[...] I'm also at a difficult crossroads in my composing—I have trouble with my tendency to use "beautiful" sounds or nice, accessible harmonic relationships - I dislike it and want to move out into territory where the superficial reactions to it are not in terms of pretty or sweet or soft—you know. [...]

As far as participation with CIE, I feel unsure as to whether it is the appropriate context for my work, at present. I certainly feel as a performer I would be an asset to the group—and I would benefit greatly from the technological emphasis—(this is certainly my weakness.) As a composer I could attempt to divert some of my work into the CIE channels, but feel very unsure how this might manifest, even with an expanded concept of the group. What do you think? Again, working with you is very tempting to me, but more important is that our friendship continue even if we can't align ourselves in CIE. (Fisher 1980)

Fisher eventually found CIE's focus on technology tiresome, and expressed her decision to stop doing *Rainforest* for a period partly as a reaction to problematic group dynamics and rituals of CIE "family" life.

I think partly it was that I felt the emphasis became so obviously on the technology and how big your object was and, you know, it's just like sibling stuff. [...] you know, there was always the decision when you got to the space where your table was going to be and where your objects were going to hang and which speaker you got to use and, you know, there would always be maybe eight speakers or four speakers and there would always be two that were better and two that were not quite as good. And so, who's going to get which one and, you know, it was funny that way. It became kind of a family joke. You know, that process of deciding who would sit where and which speakers we'd get to use and all that kind of thing. (Fisher, 2003)

A significant break with CIE seems to have occurred around this time: in a CIE press package circa 1979, her biography appears along with those of Tudor, DeMarinis, Driscoll, Edelstein, Jones, Kalve and Viola (CIE 1979); in a revised version of the package circa 1980, she is absent (CIE 1980a). "I kind of formally absented myself" from CIE, Fisher has said (Fisher 2003); her friendships and professional connections with members of CIE continued, however: for instance, she and John Driscoll co-presented an evening of their work in November 1983 at Cornell University, Driscoll taking the first half of the concert (with Fisher performing on musical saw) and Fisher making a solo performance after the interval (Herbert F. Johnson Museum of Art 1983).

Fisher did not perform in installations of *Rainforest 4* between 1976 and 1996, until a number of the original core group gathered for a memorial celebration in New York City following Tudor's death. She then participated in a subsequent *Rainforest 4* engagement at Lincoln Center in 1998, but afterward stated that she would no longer perform the piece:

[...] the possibility of doing *Rainforest* in any way, shape or form leaves me with terribly mixed feelings. in 1998 I made a pact with myself that the Lincoln Center performances would be my very last [...] The spiritual angle here is simply that I've done what I was meant to do performing this profound work. I vowed to retire after Lincoln Center which was the right decision to make. Despite the temptation, I am at peace with that decision. Among the glitter, lights, shadows, chirping and wheezing—you remember it was a truly transcendent final night—I experienced the culmination of what I knew *Rainforest* could be and could mean and I knew this was the right time to step down. Yet, at the same time I can see myself talking about it or writing about it for the rest of my life as the occasion arises, discovering something new about the work and the experience [...] (Fisher 2004)



Figure 6-18. Linda Fisher listening to the oil drum at Lincoln Center, July 1998. Photograph by John Driscoll.

CIE following the 1976 Festival d'Automne

The presentation of *Rainforest* at l'Éspace Pierre Cardin in November 1976 marked the 17th time the piece had been mounted in three years, since its workshop performance in 1973. 1976 was *Rainforest 4*'s busiest year so far, with nine installations, and such a busy schedule of touring and performances was not achieved again in any year from 1977 to 1982: *Rainforest 4* was only produced once or twice a year during this period, at the end of which Composers Inside Electronics entered into a long period of dormancy (though Tudor and the other members remained extremely active in their fields).

Although Composers Inside Electronics scaled back the number of their *Rainforest 4* engagements after the 1976 Paris excursion, the ones which they took on tended to be of a longer duration, involving multiple performances over a period of days, sometimes including performances of works by members other than Tudor. And although *Rainforest 4* remained, to repeat Ralph Jones' words, "the star around which we all orbited" (Jones 2001), Composers Inside Electronics also began to present concerts and concert series which did not include the piece, but rather directed the focus onto other work by members of the group. In addition, through the remainder of the 1970s, CIE entered into a number of residencies lasting between one week and one month, some of which were dedicated to research projects further extending the sculptural loudspeaker concepts explored through *Rainforest 4*.

After CIE's return to the USA following their extended performances of *Rainforest 4* at l'Éspace Pierre Cardin, there was one more performance of the piece in 1976 which is worth noting. Merce Cunningham was invited to take part in a new television series documenting the work of American choreographers, *Dance In America*. In a studio in Nashville, Tennessee, Cunningham created an *Event for Television* montaging together excerpts of eight of his dances, including *RainForest* "almost in its entirety" (Vaughan 1997, 199). Several weeks later, on November 20 in a studio in New York City, Linda Fisher, Martin Kalve, Bill Viola and David Tudor set up and performed a version of *Rainforest 4* which was used as the soundtrack for the *RainForest* segment of the dance video.

In 1977, over three evenings January 6-8 at The Kitchen in New York City, CIE presented its first series of concerts which did not include *Rainforest 4*. Following so closely on the Festival d'Automne the previous October, it is no surprise that the Kitchen programme was primarily made up of works which had been performed in Paris. Tudor's new work *Pulsers* was again highlighted as a solo performance on two nights; Phil Edelstein and Marsha Harris again presented their matrimonial metaphor with chair and elastic, this time under its correct title, *Shrieks and*

Nuptials; John Driscoll performed *Listening Out Loud*, again with Edelstein and Bill Viola on musical saws, as well as presenting a solo piece for "repetitive mechanical sounds, modulations and small electronic sounds" (CIE 1977a) entitled *Under the Putting Green*; Viola presented his *Gong*, again with Linda Fisher as co-performer; and Fisher on two evenings presented a work simply entitled *Solo Synthesizer Music*, with Martin Kalve as co-performer. This piece was a keyboard synthesizer-based composition in three six-minute sections, made with techniques reflecting both the influence of pattern minimalism such as the work of Philip Glass (particularly *Music in Similar Motion* and *Music in Contrary Motion*, both composed in 1969 for electric organ), as well as the layered music of Terry Riley: using tape loops, "closely related, slowly expanding patterns" (CIE 1977a) were accumulated, with each new section incorporating recordings of the sections before it. It seems that this was a version of the work which Fisher had been preparing for possible performance in Paris, but had withdrawn due in part to feeling "self-conscious" (Fisher 2003) about its differentiation from the homemade-circuit pieces and less traditionally "musical" works which were CIE's stated focus.

Closely following on CIE's three evenings at The Kitchen, an invitation to Tudor and CIE from Pauline Oliveros led to a research residency at the Centre for Music Experiment at the University of California San Diego, where she was then Director, between January 25 and February 7 1977. The participants included Tudor, Driscoll, Edelstein, Viola and DeMarinis, and while it included a performance of *Rainforest 4*, it was also substantially dedicated to investigation of new technologies and extension of technique, as well as being "a bit of a break" which included field recording expeditions, both whale watching and into the Anza Borrego desert (Edelstein 2006a). John Driscoll made a recording of musical saws being played in one of the university's paddleball courts (Driscoll 1977). Focus on *Rainforest* included "seminars and

demonstration of the project" which John Driscoll observed, in his report on the residency,

[...] stimulated an awareness in an analog approach to electronics and acoustics, as well as demonstrating the capacity for collaboration in an ongoing manner. I felt it was valuable to show the diversification and integration of a group such as Composers Inside Electronics. It was also vital to make David Tudor's manner of working accessible, for it demonstrates a desire for penetrating the obvious, and a penchant for finding the underlying physical phenomena which becomes more obvious, in time, to those working on it. The work with *Rainforest* once again showed the need for simplicity in desire, and openness in receptivity to your results. (Driscoll 1977)

This description resonates with Tudor's suggestion that *Rainforest* is "almost self-teaching" (Tudor 1988a), but also makes it clear that an understanding of Tudor's "manner of working" is in fact important, if not a prerequisite. This "oral culture" aspect to the continuation of *Rainforest 4* will be considered in Chapter 7.

While Driscoll reported that part of the residency was taken up with constructing new transduced objects for use in *Rainforest 4*, Phil Edelstein recalled making use of a large computer in an unsuccessful attempt to recreate delay techniques he had developed on a PDP11 minicomputer in Albany, and remembers Paul DeMarinis "cooking with delay line boxes much more happily" than he was (Edelstein 2006a). John Driscoll furthered a project he had begun in 1975, experimenting with a motorized loudspeaker able to move through 360 degrees and project sound in all directions, according to a precise control signal.

Rotating/directional loudspeaker research, 1977-79

"The rotating loudspeaker project was something that David never wanted to get involved with", Driscoll stated (2002), but Tudor lent his support enthusiastically to a National Endowment for the Arts grant

application written in 1977 on behalf of CIE by Driscoll and himself, seeking funding for moving speaker research. Tudor was concurrently working with Billy Klüver and others on an Experiments in Art and Technology-supported project known as *Island Eye Island Ear*, which if realized would have occupied an entire small island: locations in Sweden, the Adirondacks and the Thousand Islands region of the St. Lawrence River were investigated over a period of years, but none proved feasible. Tudor's role would have involved projection of audio (derived from field recordings made on the island) over long distances, using loudspeakers which produced focused "beams" of sound (E.A.T. 1977). The NEA funding application combines aspects of Tudor's focused loudspeaker research with Driscoll's interest in motorized speakers, as Tudor's diagrams accompanying the application show (Figure 6-19). Tudor's "Personal Statement" of October 25 1977 accompanying the application is of interest because of further illumination it sheds on *Rainforest*. Illumination is perhaps not the appropriate word, however, since it again calls into question the numbering of the various "versions" of the piece. Tudor wrote:

[...] The conception of loudspeakers as unique instruments has been evidenced in several of my works, notably *Bandoneon !* and *Rainforest*.

In order to accomplish the design of instrumental loudspeakers having directional / rotational capabilities of qualities adequate to musical composition, a collaborative effort is required, of people having electronic, mechanical, design and compositional abilities, and also musical imagination. The group of composers now working with me, Composers Inside Electronics, has already demonstrated these abilities in great degree.

As with the history of *Rainforest*, now in its fifth version, I envision that our group research will produce not one, but several works of musical interest. The work done can be useful to other composers as well, and it will be our concern to make the results of our research public and available to everyone interested.
(CIE 1977a)

Recalling that it was not until at least 1980 that the large group version of *Rainforest* was dubbed "*Rainforest 4*", it is clear from this document that in 1977 Tudor thought of this version as being the *fifth* distinct realisation of his *Rainforest* concept (perhaps stemming from the existence of the two voice-based "versions" with John Cage, circa 1969-70, later considered together as a single "version"). There clearly remains considerable potential for confusion in discussion of *Rainforest's* stages of development.

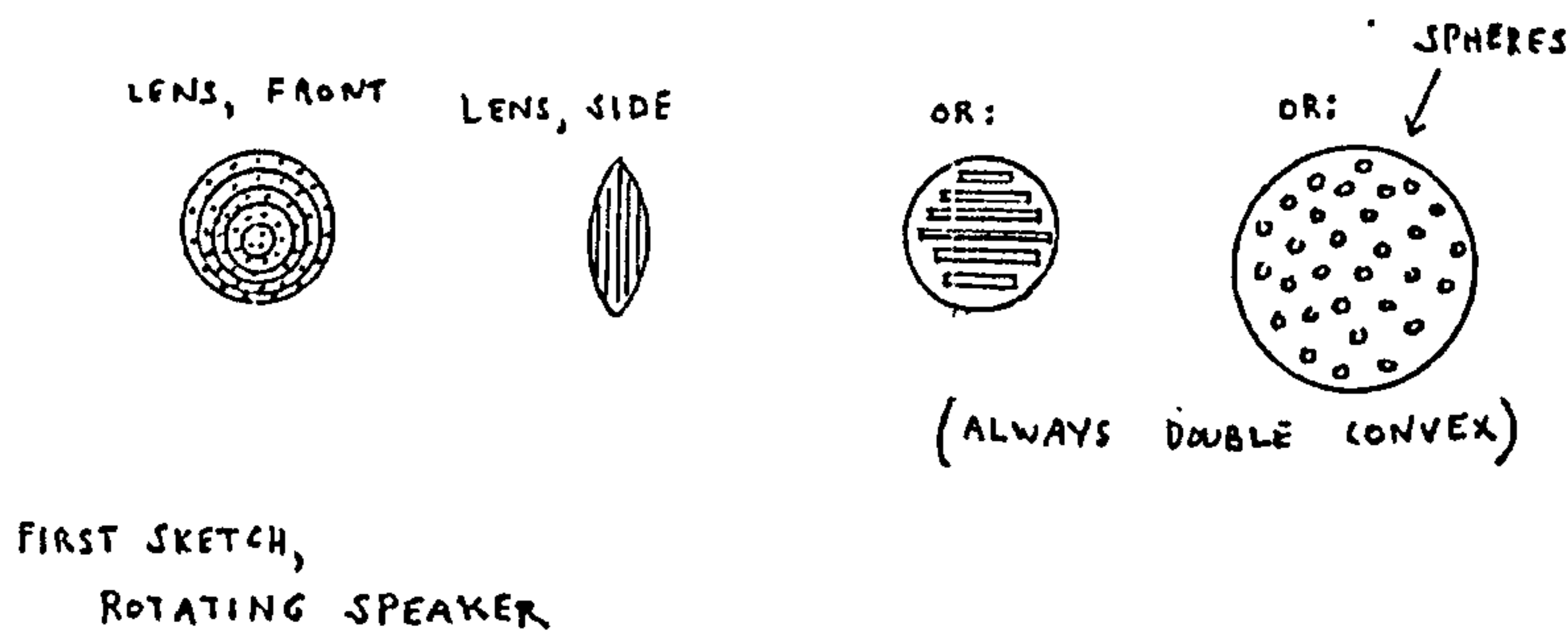
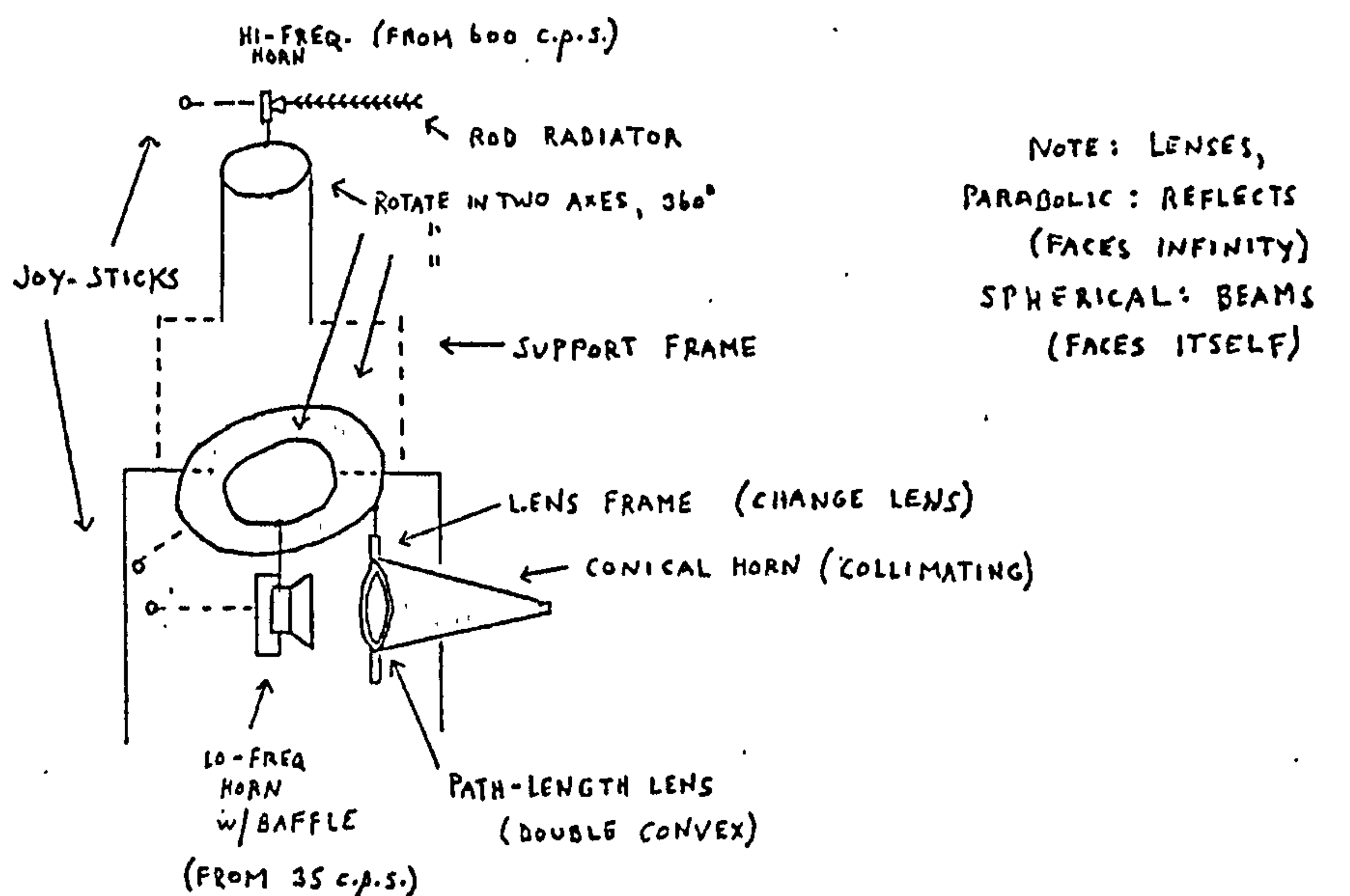

FIRST SKETCH,
ROTATING SPEAKER

d. tudor '77

Figure 6-19. David Tudor's "first sketch" for rotating, highly directional loudspeaker research funding application submitted to the National Endowment for the Arts (CIE 1977b).

CIE's application to the NEA to fund the rotating loudspeaker project, with the goal of exploring "spatial positioning as a compositional technique" (CIE 1977b), was successful and a grant of \$15,000 was given for work to be carried out between July of 1978 and June of 1979. Driscoll recalled that

[...] the original intent, and David and I had many a night discussing it, was originally to make another *Rainforest* scale project that we would have toured, you know, pieces that would have come out of that, you know, speaker research. I was left with the sense that we were actually creating a monster, a mechanical monster, electro-mechanical monster, beyond the proportion of *Rainforest*. [...] you'd have devices that could rotate with performers on them, or manipulating them. (Driscoll 2002)

Tudor's fascination with loudspeakers which focused sound and allowed it to be "beamed" over long distances led to a related NEA-funded research project in 1978, conducted over five weeks in November and December at Media Study/Buffalo by himself, John Driscoll, Martin Kalve and Ralph Jones. An account of the residency published by the host organisation described CIE's "special, highly directional loudspeaker units [...] capable of being 'aimed' or 'panned' in performance. The composers have hypothesized that, using such speakers in their performance, they can achieve interactions among their individual sounds, and between their sounds and the acoustical space in which they are performing". A three-part program of research included, first, developing means of focusing sound waves over a wide range of frequencies; second, continuation of investigation into means of rotating the speakers in several planes; and third, development of "source sounds appropriate to the context". Prototype speakers were developed and their frequency response at multiple angles was analyzed by Jones and Driscoll (Media Study/Buffalo 1979).

It should be noted that Ralph Jones had already incorporated focused loudspeaker-objects into *Rainforest 4*, building compound objects which addressed a single listener at a time:

One of the things that I brought to the piece was making objects that focused sound, so you're within this sonic ecology but you can come and experience the sound of a particular object in a very focused way. The reflector object [nested steel bowls] was a very good example of that, it was like a sound shower, and when you were under that you experienced mostly the sound of that object, so it gave you acoustically the same sort of experience that you would have if you bit on Phil's copper strip and plugged your ears or something like that. (Jones 2001)

Biting down on objects was a method of listening via bone conductance encouraged by *Rainforest's* performers.

In addition to loudspeaker research, over four weeks at Media Study/ Buffalo each CIE member in residence presented a Sunday public lecture under the series title, "Aspects of Collaboration in Electronic Performance". Driscoll spoke on "Automated Puppetry", surveying the history of sonic automata by way of contextualising his own work bridging music and sculpture. Kalve's talk, "The Art of Playing Electronic Instruments", was "an exposition of various instruments used in electronic performance, and their respective playing techniques [...] showing how different playing techniques arrive at a balance in a collaborative performance situation" (Media Study/ Buffalo 1979).

Ralph Jones dealt directly with CIE as subject material for his presentation, "Design and Collaborative Composition", which introduced

[...] particular strategies of collaboration that have developed among the members of Composers Inside Electronics during their five years of working together. Jones distinguished the function of design, which he defined as "the making of a plan to make something", from that of composition, "the act of putting together a finished product". [...] he showed that, in collaborative music-making, the individual may design a system of interactions among the composer/performers, thus freeing the composition of the finished piece for the collaborative effort of the ensemble, investing the resulting work with "the spirit of discovery". (Media Study/ Buffalo 1979)

David Tudor gave the final lecture of the series, speaking on "Altering Signal Sources in Real Time—Transformations by electronic and non-electronic means; speech and other sound simulations; or, how to make the ordinary extraordinary" (this talk has already been briefly described earlier in this chapter). John Driscoll states that it was unique in his experience, as a clearly presented, in-depth account of Tudor's performance practice—an uncharacteristically open moment for Tudor, whose general reluctance to discuss such topics was well-known. Unfortunately, although Tudor's talk was recorded along with those of the other three resident artists, and Media Study/Buffalo's account of the series as published in early 1979 states that "all four talks [...] are currently being transcribed and edited by the composers for publication" (Media Study/Buffalo 1979), the original documentation of these talks has not been located, nor have any transcripts.

Forest Speech, 1976-1978

The inclusion of "speech and other sound simulations" as a topic in Tudor's presentation at Media Study/Buffalo reflects an area of his compositional investigations between 1976 and 1978 which should now be mentioned, as a direct conceptual offshoot of *Rainforest 4*.

Forest Speech was first developed by Tudor in 1976/1977 as an accompaniment for Merce Cunningham *Events*. It is not certain how many performances Tudor gave of his original version since records of music performed with Cunningham *Events* are rarely kept. There is a relative abundance of documentation for one specific *Event* date, however—March 20 1977, on which Tudor performed *Forest Speech* as a duo with Martin Kalve, in the gymnasium of Barnard College in New York City. That date appears on what is perhaps Tudor's earliest draft of a *Forest Speech* score diagram (Figure 6-20). In 1978 Tudor revised the piece for ensemble performance, at The Kitchen in New York City, by four

members of Composers Inside Electronics: himself; Kalve, John Driscoll and Ralph Jones.

Forest Speech was essentially a scaled-down *Rainforest 4* with a more specific sonic agenda. Its setup, as shown in Tudor's diagrams for the 1977 *Event* performance (Figure 6-20) and the 1978 group version (Figure 6-22), is virtually identical to earlier diagrams for *Rainforest 4*; *Forest Speech* is differentiated by the type of sounds which are to be introduced into the four loudspeaker-objects.

Rainforest 4 admitted of any sounds, save for "already composed" musics (Tudor 1980). *Forest Speech* was not dissimilar: another 1977 draft diagram for that piece also bears the injunction that "no composed music" is to be used as input (Tudor 1977a). *Forest Speech's* twist on *Rainforest*, however—suggested by its title—is that the piece is intended to have a vocal identity, and "any simulation of vocal sound" is invited as source material (Tudor 1978b). *Forest Speech* precedes several other works which were also concerned with aspects of speech: *Phonemes* (1981), *Likeness to Voices* (1982), and *Dialects* (1984). The works are directly related: the sounds for *Phonemes*

[...] reminded me of speech. The sounds were very short, so I called the piece *Phonemes*. I then made a later version of it to be a concert piece. That one features the longer sounds rather than simply the short sounds and that reminded me of listening to a foreign language that you can't possibly understand but you know that it is a language. So I called that one *Dialects*. (Tudor 1988a)

Much as the "versions" of *Rainforest* are better thought of as stages along a continuum, so are these vocalic works, one extending into the next. They are connected to the end of *Rainforest's* developmental trajectory via *Forest Speech*, which is both a sort of postscript to the *Rainforest* project proper, and the beginning of what seems to have been a new thread of research. If we recall the voice-based experiments circa 1969-1970 which Tudor defined as *Rainforest 2*, however, that thread

may actually not have been so new. Clearly Tudor was interested at an earlier point in time in investing *Rainforest* with a vocalic identity.

Tudor's programme note for the 1978 CIE performance of *Forest Speech* reads as follows:

Forest Speech

Synthetic voicings & plosive bursts. Formant resonances, produced with the natural comb-filtering action of "Rainforest" instruments, are used to create vocal illusions.

The originating sound materials can be various, & processed with vocoder-like circuit networks.

Performed live with multiplexed output circuitry.

Developed in 1976, group version 1978.

(CIE 1978)

Besides being the sole occasion for performance of the ensemble version of *Forest Speech*, the 1978 Kitchen performances, over four nights between September 20 and 23, were also unique in the history of CIE in that each evening was dedicated to a single work by one of the four performers, with all four of the musicians realising each piece together. Tudor said that "we wanted to work together, but we sort of didn't. None of us was willing to really make a group piece. So we decided to perform as a group with the pieces that we each had. I had my *Forest Speech*, which is a variation of *Rainforest*, and I gave them the block diagram of that. [...] everyone realized the other people's pieces with their own stuff, and it was all perfectly possible. And it was very interesting to see how other people did it" (Tudor 1988a).

The most important device in Tudor's *Forest Speech* setup seems to have been a "photocell key" obtained in 1968 from Hugh LeCaine at Canada's National Research Council laboratories, where engineer René

Farley had developed them for use in experimental instruments. LeCaine had provided John Cage with two variations on the design (LeCaine 1968) and Cage responded with the note: "David Tudor tells me the pressure-sensitive amplitude controls are a pleasure and he is testing them and perhaps making further suggestions" (Cage 1968).

The key is simply a variable resistor modeled on a plastic organ key: depressing the key opens a shutter separating a light source and a photoresistor, allowing signal to flow through the device. Tudor said of these keys, "my piece calls for those photocell switches... it calls for a momentary increase or decrease of gain. But however... the gain factor isn't as important as the gating factor, so any switch, any electronic gate will be acceptable. It's simply to make a perceptible difference above a certain level, or for that matter below it" (Tudor 1988a). The key, labeled in the diagram in Figure 6-22 as "touch-sensitive gate, switch, etc.", makes possible "phonemic" interjections based on source sound materials shown on the left side of the diagram as inputs to Tudor's matrix switch box (the matrix switch had by 1976 become a ubiquitous item on his table of devices, making complex interconnections easy to achieve). Source materials include two tape recorders, various types of microphones, and a white noise generator. "Any simulation of vocal sound" may be used as input, reads a note on another version of the diagram (Tudor 1978b). Also important for achieving vocalic qualities is the presence of a "modulator, vocoder, etc", which is used as a processor for the source sound materials, and is placed in a potential feedback loop, depending on how the matrix switch is set.

Approaching the "vocalic" aspect of *Forest Speech* presented a problem for John Driscoll, who felt that CIE's Kitchen performance was undermined by a lack of preparation and rehearsal time:

I seem to recall he had a patch [a score diagram] and he spoke very briefly about it, but I didn't think I had been very well prepared to develop the vocal characteristic of it. Partially because it was really source material based, in other words, the *Rainforest* side we

all knew, but the real question was then, how do you get it to have that [vocal] characteristic? It obviously has to be in part derived from the source materials. And I think part of the problem for me was I didn't really know if he meant it literally or sort of figuratively—should it be voice-like, should it be voice as a starting point. [...] None of those things were sort of answered for me, and it would have really helped. (Driscoll 2002)

Ralph Jones concurs that Tudor offered little by way of guidance but suggests that was strategic on Tudor's part, a puzzle for the other three performers to solve:

You know, with David there wasn't much discussion. There really wasn't. He was very laconic about his work. I think he probably said maybe two sentences to us. Something having to do with producing voice-like phenomena or formant phenomena, and that was pretty much it. And it was up to you to interpret that and figure out how the hell you were going to make that happen. And I think that was really intentional on his part, I mean obviously it was. The reason maybe was that I always had the sense that David, more than just working in a collaborative structure, David really valued our input and the very different ways that we would approach his work. (Jones 2001)

Jones recalled in detail the tactics he used to produce vocalic sounds for the piece, which brought his experience with ultrasonics into play:

[...] it was very interesting. One of the things I used in that was heterodyning ultrasonic signals into the object—sending two ultrasonic signals into the object and letting the nonlinearity of the transducer and the object itself produce the difference tones that came down to the audible range. And the other technique that I used in that is, I built a (now unfortunately gone) setup of digital filters using a shift register technique. And I used those again with ultrasonic excitation to produce formants that I brought through the objects". (Jones 2001)

Driscoll could not recall precisely what his soundmaking methods were, but said: "I remember the dilemma of not knowing what I was really supposed to do, so much as how to do it. And I felt if I had had a better handle on what the result was [supposed to be], I know I could have gone off then and developed the material. [...] we had very little prep time" (Driscoll 2002).

Figure 6-21. Composers' team elements performing John Driscoll's *Ebura and Mula* at The Kitchen, New York City, September 20, 1976. From left to right: John Driscoll, Ralph Jans, Martin Kalve, David Tudor. Photographs by Sam Fine.

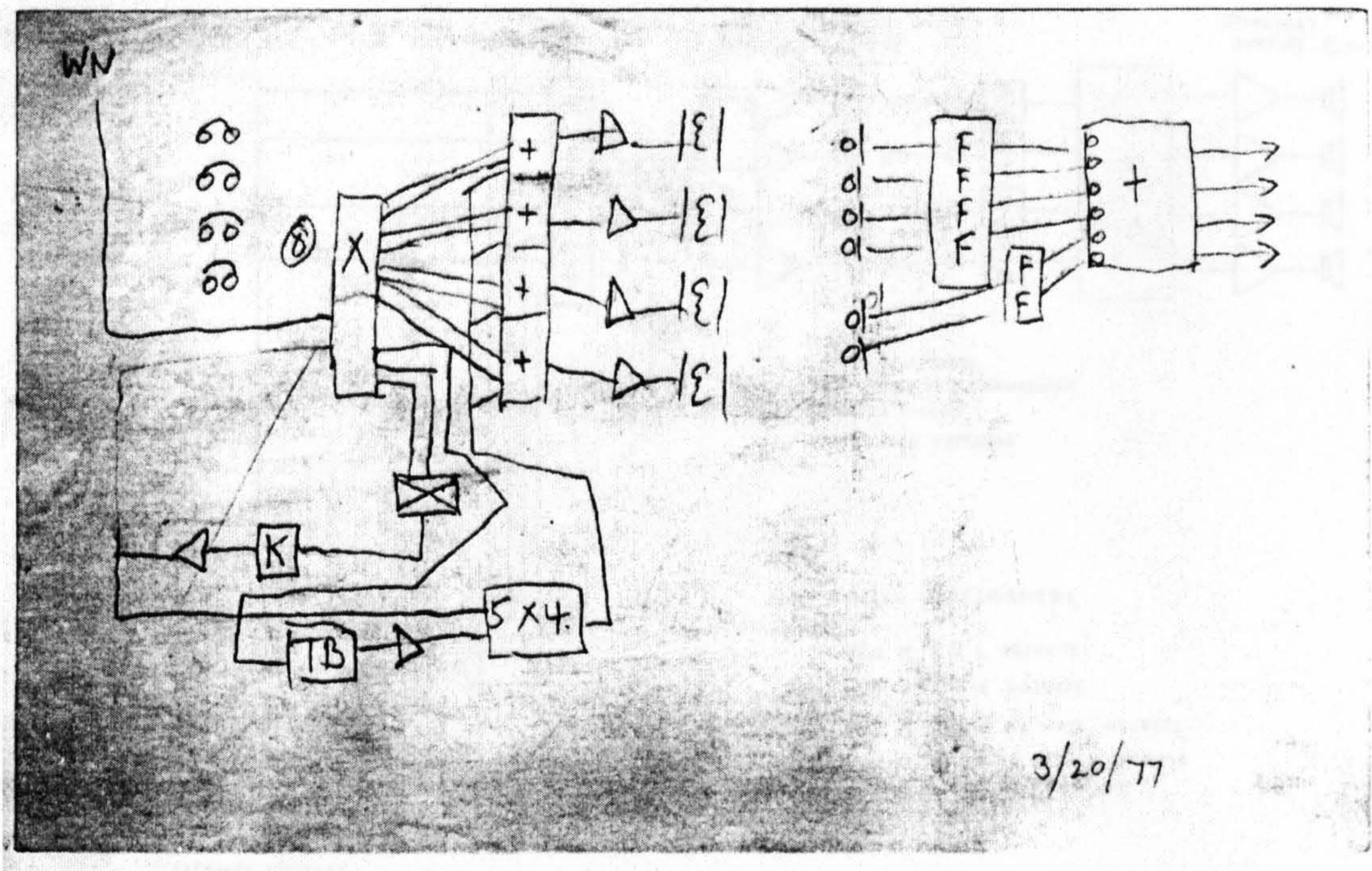

Figure 6-20. Diagram by David Tudor for performance of *Forest Speech*, March 20 1977, accompanying a Merce Cunningham Dance Company *Event* at Barnard College, New York City. The performance was made as a duo, with Martin Kalve. Object labeled "K" is one of the "photocell keys" obtained by Tudor from the National Research Council of Canada. "F" indicates a filter. "WN" is a white noise source. "TB" is unidentified but correlates with the position of bandpass filters as shown in other versions of *Forest Speech* score diagrams such as that in Figure 6-22 (Tudor 1977b).

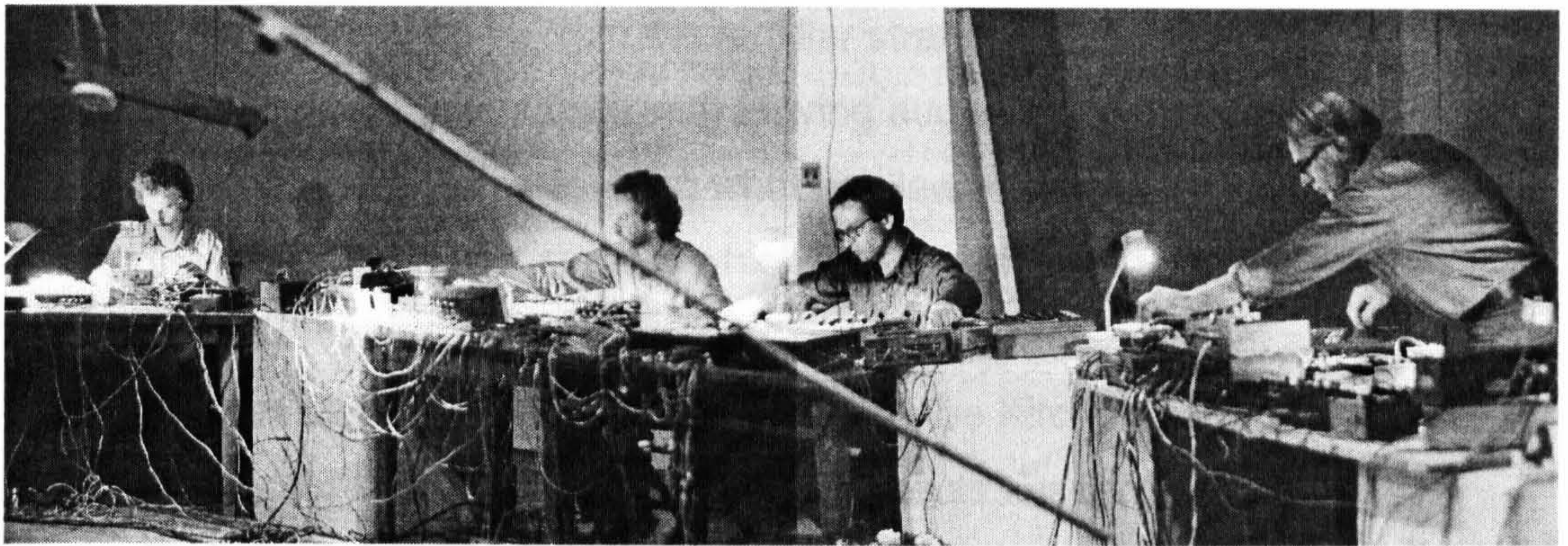
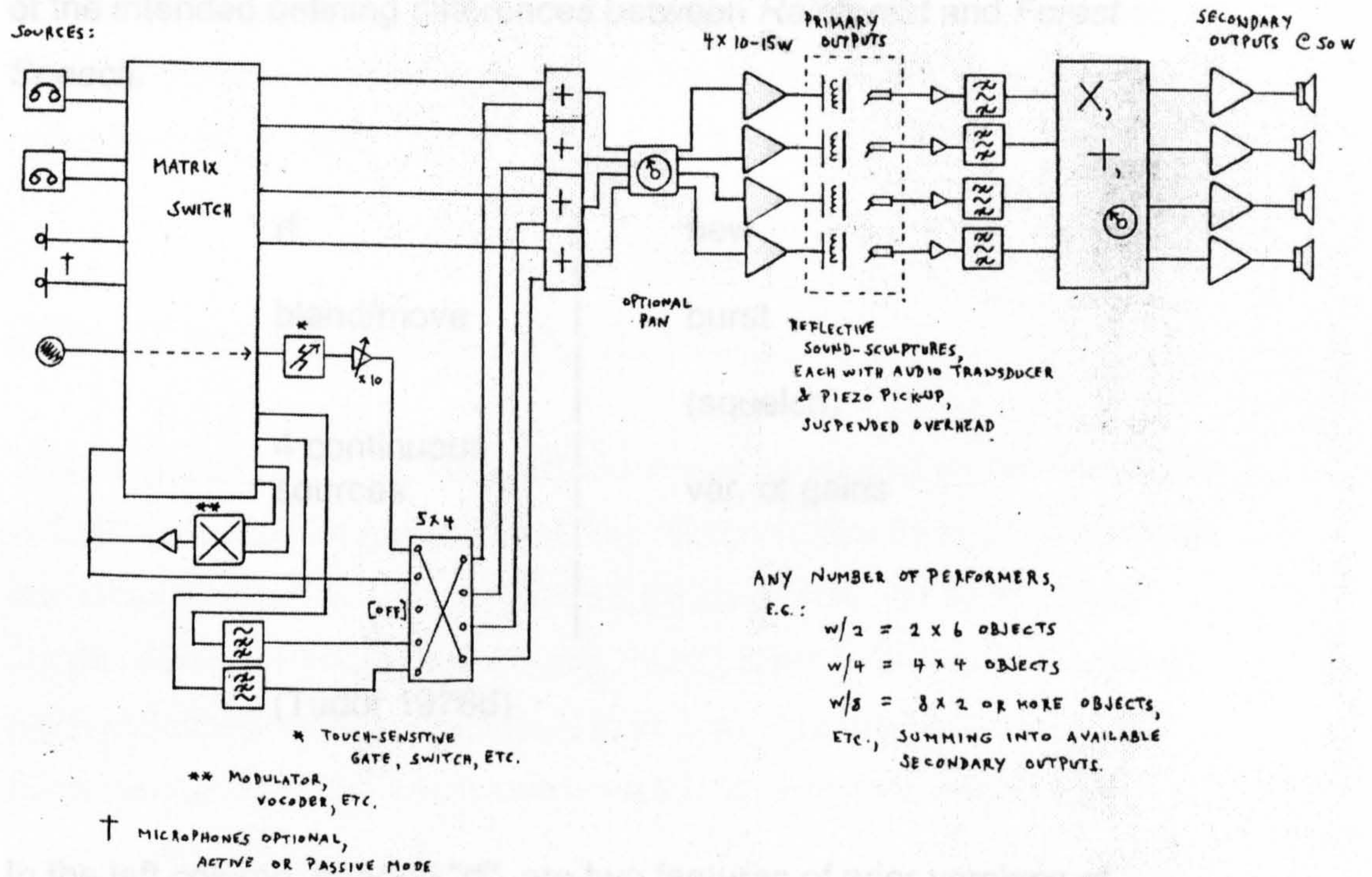

Figure 6-21. Composers Inside Electronics performing John Driscoll's *Ebers and Mole* at The Kitchen, New York City, September 23 1978. From left to right: John Driscoll, Ralph Jones, Martin Kalve, David Tudor. Photographs by Stan Ries.



FOREST SPEECH

d. tudor '78 - '79

Figure 6-22. Score diagram for *Forest Speech* (Tudor 1978a). Rectangular section labeled "Primary Outputs" includes four loudspeaker-objects, each with transducer and contact microphone. Triangular elements are amplification stages. At left, "Sources" include two tape decks, two microphones, and a white noise generator. "Touch-sensitive gate, switch, etc." was, in Tudor's realisation, one of the "photocell keys" obtained from the National Research Council of Canada. Other symbols used include "X" (modulation), "+" (mixing), wavy lines indicating high-, low- and bandpass filters, and circle with arrow indicating a quadrasonic panning device.

Another part of the problem, Driscoll explained, was the "shift of mentality" required to move from the familiar strategies for performing *Rainforest 4*, a sound installation with moving audience and multiple possible perspectives, to performing what he viewed as something "closer to where *Rainforest* started, which was the table-top, you know, amplified table-top. And you know, that's a very different equation, as we found as we were trying that" (Driscoll 2002). In the Kitchen performance, each player had his own independent set of objects suspended in the space; Tudor's diagram in Figure 6-22 states that for an ensemble of four, each player should have four objects.

A working note exists which appears to record Tudor's thoughts on some of the intended defining differences between *Rainforest* and *Forest Speech*.

rf		new
blend/move		burst
		(squelch)
4 continuous sources		var. of gains

(Tudor 1976d)

In the left column, headed "rf", are two features of prior versions of *Rainforest*: "4 continuous sources" (as in *Rainforest 3*, for which Tudor employed two stereo cassette recorders as sources), with the notation "blend/move". *Rainforest* was about continuous movement and development of layered sound materials; the "new" piece, *Forest Speech*, is distinguished from *Rainforest* by its specific use of "squelch" (noise gating, via the photocell key or other devices) to create bursts of sound, with "var. [variation] of gains".

A recording of a performance of *Forest Speech* with the Merce Cunningham Dance Company circa 1976-1977 (excerpted on the accompanying audio CD) was obtained from the Cunningham Dance Foundation. Curiously, it seems to be barely differentiated from *Rainforest*; the "vocal illusions" which Tudor suggests ought to make the piece distinct are little in evidence. What is most surprising is the appearance, about ten minutes into the 45-minute recording (which unfortunately ends before the conclusion of the performance), of familiar sounds from Tudor's Pepsi Pavilion tape library. The prevalence of Pepsi library sounds (see Chapter 4) throughout the piece—some of which fit the description "vocalic", such as the sonifications of brainwave activity—strongly recalls 1972's *Rainforest 3*, although *Forest Speech* tends to be more densely layered than the earlier piece: sheets of filtered noise fade in and out.

Other CIE works performed at The Kitchen, 1978

Tudor's group version of *Forest Speech* was presented on the final night of CIE's four-night engagement at The Kitchen . The three prior evenings had been devoted to works by John Driscoll (*Ebers and Mole*), Ralph Jones (*Star Networks at the Singing Point*), and Martin Kalve (*Earthing*). Each of these pieces is interesting in its own right, and all three show direct connections to Tudor's two streams of work, with transduced objects and with feedback.

Ebers and Mole was described by John Driscoll as "an interfeed [...] *Ebers and Mole* was the source material, and then the interfeed was the process we used to perform it" (Driscoll 2002). The piece had its origins in a piece entitled *Bamboo* which Driscoll developed during the CIE's Center for Music Experiment residency in 1977, and a version of the work was also used as accompaniment for a dance by Maida Withers' Dance Construction Company, with which Driscoll worked in Washington DC.

Bamboo's title came from the piece's central processor: a length of bamboo suspended, and used *Rainforest*-loudspeaker style to modify sounds. The title of *Ebers and Mole* referred to "I think, two physicists. I was reading something and their names came up as reference, and I just loved the combination of names. It didn't go any further than that, it just sounded good" (Driscoll 2002).



Figure 6-23. John Driscoll with performance setup for *Ebers and Mole*, ca. 1978. Driscoll is plucking metal strip "twangers" fixed to the top of plexiglass blocks. Photograph courtesy John Driscoll.

Driscoll's diagram for *Ebers and Mole* in Figure 6-24 shows that each performer had essentially the same setup:

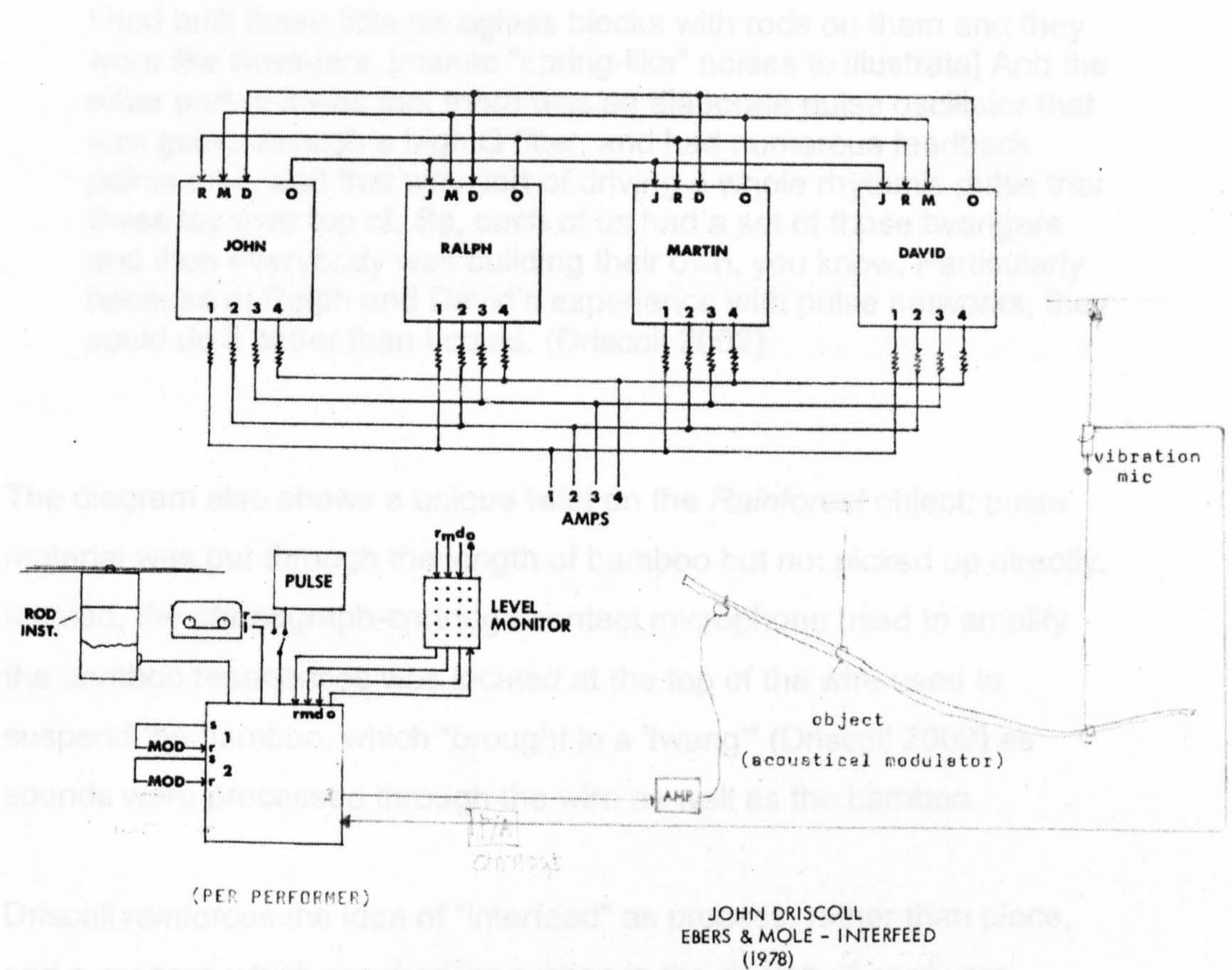

Figure 6-24. John Driscoll score diagram for *Ebers and Mole* as performed at The Kitchen, September 20 1978 (Driscoll 1978). "Rod inst." shows side view of plexiglass-block "twangers". Other inputs per performer include pulse generator, cassette deck, and two modulation circuits. A suspended length of bamboo is shown used as an acoustical modulator, in the same manner as a *Rainforest* loudspeaker-object. Top portion of diagram shows the "interfeed" connections between the four performers.

Driscoll's diagram for *Ebers and Mole* in Figure 6-24 shows that each performer had essentially the same setup:

I had built these little plexiglass blocks with rods on them and they were like twangers. [makes "spring-like" noises to illustrate] And the other part of it was that there was an elaborate pulse oscillator that was going through a high Q filter, and had numerous feedback points on it, and that was sort of driving a whole rhythmic pulse that these lay over top of. So, each of us had a set of those twangers and then everybody was building their own, you know. Particularly because of Ralph and David's experience with pulse networks, they could do it better than I could. (Driscoll 2002)

The diagram also shows a unique twist on the *Rainforest* object: pulse material was put through the length of bamboo but not picked up directly. Instead, the phonograph-cartridge contact microphone used to amplify the bamboo resonances was located at the top of the wire used to suspend the bamboo, which "brought in a 'twang'" (Driscoll 2002) as sounds were processed through the wire as well as the bamboo.

Driscoll reinforces the idea of "interfeed" as process, rather than piece, and a process which required innovation in the design of hardware necessary to interconnect the players: "the interfeed was less a piece as it was a collaborative structure, and that was an interesting thing we were trying to work out, because at that point it wasn't computerized at all, so how did you share storage, so to speak, and resources? It wasn't trivial at that point. You literally had to build equipment to start to accommodate that kind of thinking" (Driscoll 2002).

Ebers and Mole employed the *Rainforest* object-loudspeaker concept in its modification of sound; Martin Kalve's *Earthing* also revolved around transduced objects, two to a performer. At first glance, Kalve's score diagram (Figure 6-25) seems simply to recapitulate Tudor's *Rainforest* diagrams and concept. *Earthing's* signal chain appears much the same as *Rainforest's*, involving various stages of gain and electronic filtering, and two objects as acoustic filters. Kalve introduces a significant

innovation, however, in his use of an inductive pickup (such as an electric guitar pickup) in place of the usual contact microphone on the object. The inductive pickup is not stationary, either: it is hand-held and the performance of the piece involves "scanning" over the surface of the object, searching with the pickup for areas of particular resonance. There is no signal input for the piece; all sounds are generated by feeding the output of the inductive pickup back into the object, via filters and other processors: "By finding the resonant nodes on the surface of the object [...] and transmitting this resonance to another node, the object begins to sing" (CIE 1978).

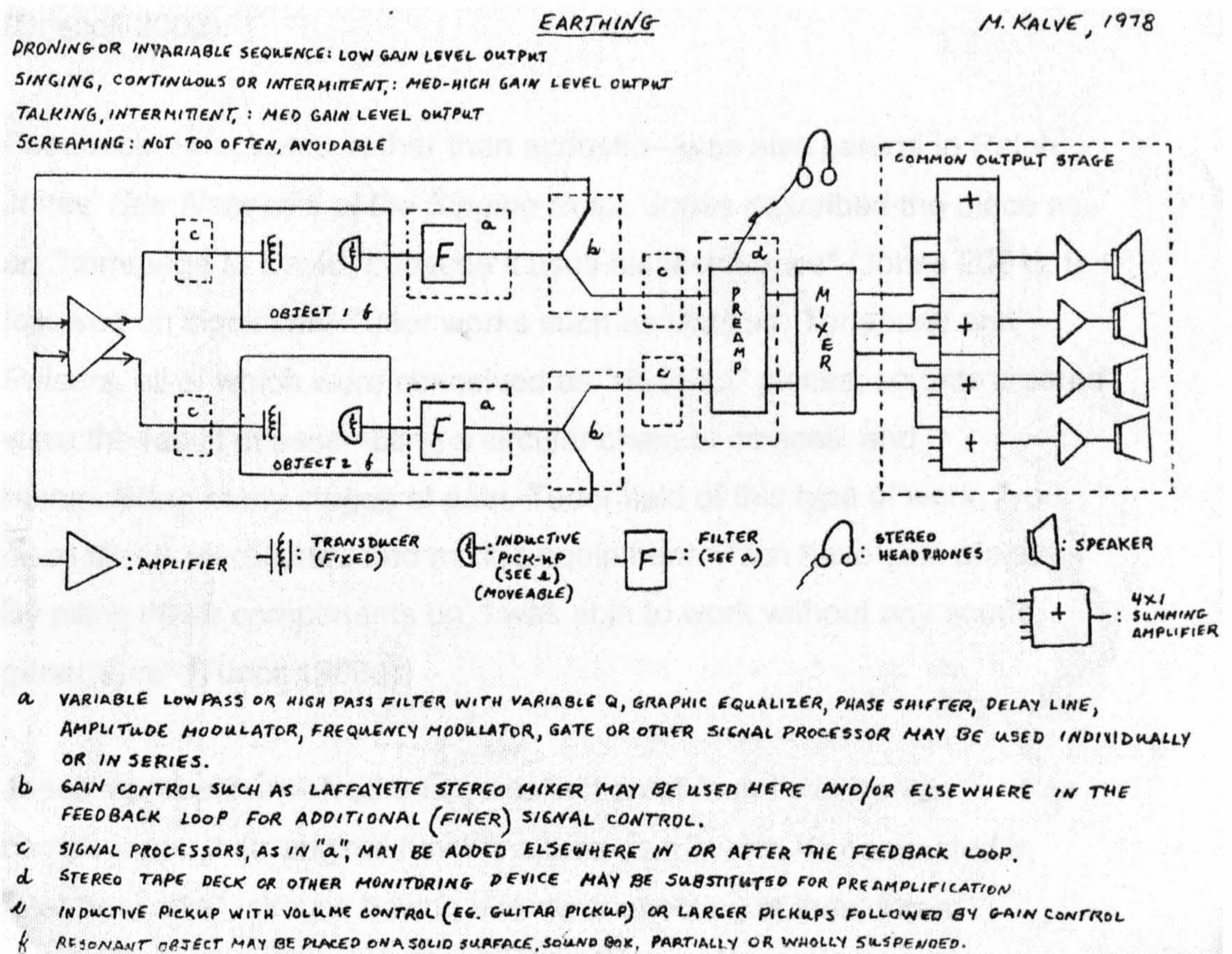

Figure 6-25. Martin Kalve, score diagram for *Earthing* (Kalve 1978). Note many similarities to David Tudor's score diagrams for versions of *Rainforest*; Kalve's innovation involves use of inductive pickups on the resonant object, rather than contact microphones. Kalve's pickups are hand-held and used to "scan" over the resonating object.

The roving pickup was described by Kalve as "the vehicle of transport on the complex topography of each object—sometimes landing on squawks, talks or raves, sometimes unable to land" (CIE 1978). The focus in Kalve's piece on vocalic sounds—"singing", "talking" and "screaming", depending on the level of signal fed back into the object, as seen in his programme notes and score diagram—is of interest in relation to the similar focus in Tudor's *Forest Speech*, with which Kalve, of all CIE members, would have had the most experience. The use of feedback with loudspeaker-objects was not itself an innovation; according to Driscoll, Tudor had occasionally used the technique, and Driscoll himself had used the related technique of reintroducing to an object sounds which had been recorded through it, to sharpen its resonant peaks (Driscoll 2002).

Feedback—electronic, rather than acoustic—was also central to Ralph Jones' *Star Networks at the Singing Point*. Jones described the piece as an "homage to David, because it uses his techniques" (Jones 2001). It followed on significant Tudor works such as *Untitled*, *Toneburst* and *Pulsers*, all of which were conceived as "no-input" pieces; sounds created were the result of assembling a circular chain of devices, and manipulating many stages of gain. Tudor said of this type of work, "you need filters, modulators and mixing equipment which have gain stages. By piling these components up, I was able to work without any sound generators" (Tudor 1988a).

Jones' approach involved a large collection of found electronic components, their original functions unknown, which he connected in "star networks", circuits having a node connecting at least three components (see Figure 6-26). As with Tudor's feedback networks, Jones' complex circuits—assembled experimentally in performance—produced a wide range of sonic behaviours; one reviewer commented on the "numerous percussive-type sounds, some as abrasive as a ratchet, as well as electronically-produced animal images and birdlike calls and flutters" which populated the Kitchen performance (La

Barbara 1979). The quality and range of sounds in the recording of CIE's performance are strikingly reminiscent of Tudor's 1972 *Untitled* as performed on tour with John Cage; Jones' piece is significantly more dense with multiple layers of chattering feedback circuits however (excerpt on accompanying CD).

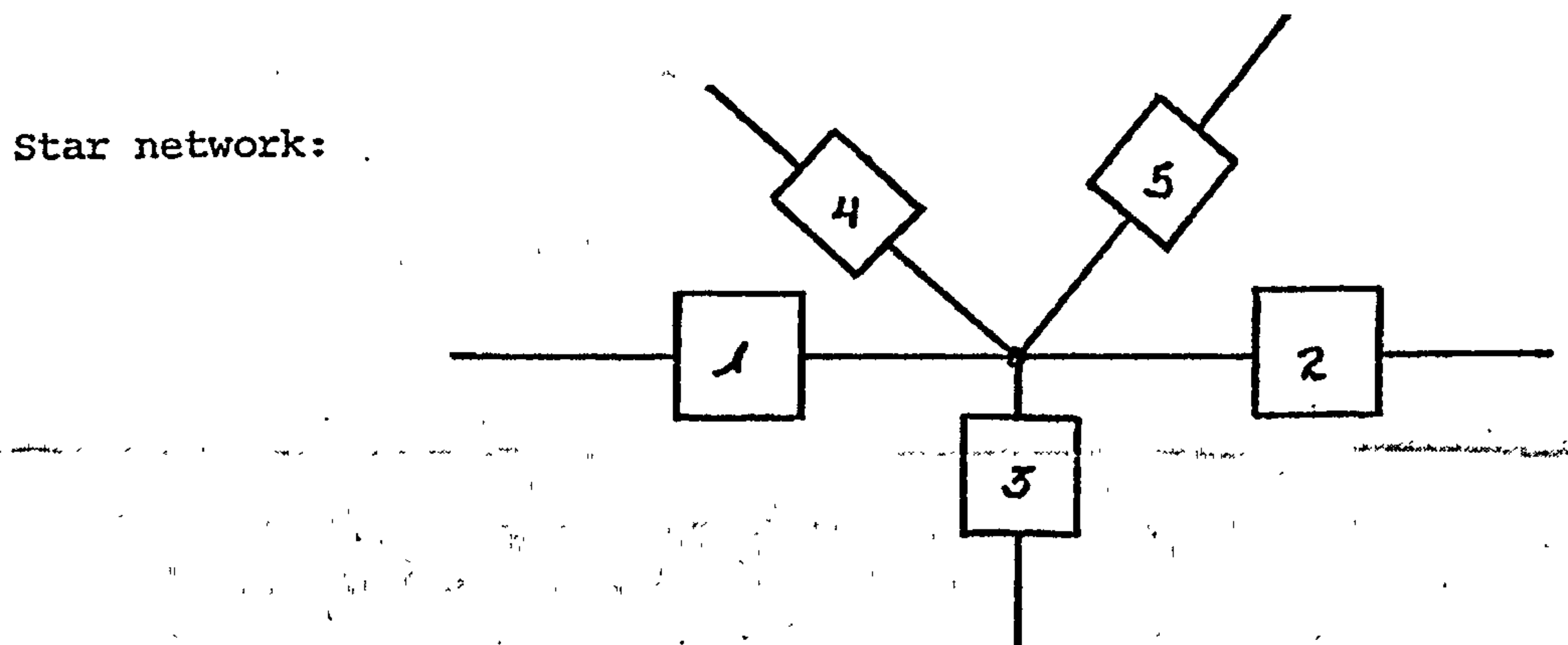

Figure 6-26. Illustration by Ralph Jones of a typical "star network" linking multiple electronic components at a central node (Jones 1980).

In a 1979 interview, Jones described the origins of the piece in this way:

When one becomes, as I am, involved in electronic circuit design, one begins to frequent places known as "surplus houses", purveyors of electronic components and instruments cast off by industry or the military. Often one finds, hidden away at the back of shelves in such establishments, electronic components which are identifiable only in a broad sense. Such items normally have enough connection terminals to suggest that their intended function was relatively complex, and, perhaps because that function remains a mystery, usually cost from 25 to 75 cents. Out of simple fascination, and an unwillingness to pass up a good deal, I've made a habit of collecting these things.

Acting on the theory that one could, perhaps with a similarly naïve spirit, design sound-producing circuits in concert, I've sought and found a basic technique for the design of complex oscillators which can be applied, by trial and error, to produce a world of sounds which are at once suggestive of natural sounds and manifestly "electronic". *Star Networks at the Singing Point* is the result of the

marriage of that technique to my collection of strange components.
(Jones 1980)

Jones mounted his found components inside a portable case which had previously held a Moog synthesizer, along with some basic amplifier circuits also scavenged from second-hand equipment, and some terminal strips which enable interconnections between devices, using leads with alligator clips (in a manner similar to Paul DeMarinis' *CKT* instrument deployed in *Rainforest 4* at the 1976 Festival d'Automne). By making interconnected star networks,

[...] what that produced was very complicated paths with complicated transfer functions, complicated frequency and phase characteristics such that it produced complete instability in the oscillation. And my original dream was to have at least eight such networks singing at any given time. I connected them up together with clip leads. And for each performance I would make several networks and then set them in feedback, and then during the course of the performance actually alter and redesign the network while the performance was happening. It was an extremely arduous performance task, really hard to do. (Jones 2001)

Jones presented the piece numerous times as a solo performance, and found he could never keep track of more than four networks, so he also used "recordings of other networks and other performances" to enrich the sound (Jones 2001). The 1978 Kitchen performance was the work's premiere, and with four players no extra sound sources were needed, however. Each performer had his own collection of components to be interconnected with alligator leads, and his own loudspeaker as well; in a model opposite to John Driscoll's integrative approach with *Ebers and Mole*, in *Star Networks* each player was on his own.

Each of us developed an instrument, in essence, which was a very diverse collection of passive components, largely inductors, capacitors and resistors, which could be connected in a lot of different ways during the performance. So then constantly we are designing and redesigning an oscillating circuit, tuning it when you

find a sound that interests you, entering it, letting it sing, taking it out, retuning or redesigning, making another sound and entering it and so on". (WBFO 1978)

Tudor, interviewed a decade later about the series, looked back on it as a great experience, as much for what he learned from the process as for its musical successes:

We were asked to give a series of programs and we decided that each one of us would take one evening and we would all perform the same work. Now that created a dilemma because the equipment for each piece is unique and only one person has it, so we were not able to duplicate the equipment. The problem became "can you realize the same electronic principles, the same composition, with other equipment?" And it turned out to be very possible and surprisingly easy. It was a joyous experience to find out that you were actually doing somebody else's music with things that you had on the shelf. (Tudor 1988a)

Tudor's comment that it was knowledge of general concepts and principles behind a piece—not specific hardware—which made it performable, seems important for the prospects of the potential continuation of specific works of Composers Inside Electronics, and other similar-minded "hardware hacker" composers of live electronic music of that era.

Ron Kuivila has written that "Tudor's music is to be practiced, not preserved", and similarly to that which Tudor suggests above, says we may

[...] consider the time-based behaviour of an electronic configuration as the identity of a musical composition. Instead of a recipe, the configuration presents a situation within which the performer is free to act without moment-by-moment directions from the composer. Having defined the situation, the composer can allow the performer free rein without worrying too much about the identity of the piece. This is an example of staying "above" the technology—conceiving of music as a practice rather than a collection of sound objects allows one to adapt to new technological situations and describe a

work "tactically" rather than "literally". By describing general conditions for a work, individuals may find solutions for realising the work which satisfy both actual sonic goals as well as philosophical ones: "One must improvise solutions as the problems appear and try to identify the best underlying strategies". (Behrman and Kuivila 1998)

Composers Inside Electronics, 1979-1982

The year 1982 marked the beginning of a long hiatus for CIE, which lasted until after Tudor's death on August 13 1996. 1979-1982, the final four years of what might be described as the first phase of Composers Inside Electronics saw a slight increase in the numbers of *Rainforest 4* presentations: in 1977 and 1978, *Rainforest 4* was only produced once per year; between 1979 and 1982 there were six presentations, three of which were once again major, multi-day engagements in European galleries, one of which featured a number of additional CIE works. A *Rainforest 4* LP record by CIE was released in 1981. In addition to CIE's *Rainforest* activity, the group (without Tudor, and also without *Rainforest 4*) was represented in the 1980 Ars Electronica festival in Linz, Austria, performing individual works.

John Driscoll comments that even with the support of Performing Artservices,

[...] every date was like months of shipping arrangements. I think in the long run, that took a real toll as well. I mean, particularly in me, more than others. I mean, I've got stacks of papers of, you know, trying to arrange for shipping this and that. And the amount of packing prep for it was just getting onerous. So, in a way, I think *Rainforest* and CIE sort of came apart [...] almost at the same time. [...] it's not like we have to apologize for not sticking with it! [...] the number of years we kept *Rainforest* alive, period, is astonishing. (Driscoll 2002)

Recalling the notion that Composers Inside Electronics represented for Tudor a mentorship project, the fading away of CIE and *Rainforest 4*

performances in the early 1980s might be viewed not only as a result of exhaustion with the effort of its production, but also as the fruits of the project itself. "By its success, it probably did [self-destruct]. In other words, it did exactly what I honestly think David intended, which was to launch our careers, and in many ways it did exactly that" (Driscoll 2002).

Ars Electronica 1980

Composers Inside Electronics, featured at the 1980 Ars Electronica festival, was represented by Ralph Jones, Phil Edelstein and John Driscoll, performing their works "several times daily" between September 11 and 13. Jones performed his *Star Networks* as a solo, as well as a new piece, *Dry Pool Soundings*, performed with Driscoll's assistance, which had been developed during a 1979 residency at Media Study/Buffalo (along with Bill Viola and John Driscoll, though it also included artist Yoshi Wada and was not billed as a CIE event). *Dry Pool Soundings* took its name from the venue of the residency, literally a dry swimming pool which Jones and the others investigated as a site of fascinating acoustics. The piece involved a directional loudspeaker built during CIE's year of NEA-funded speaker research, "consisting of a clear plastic parabolic reflector fitted with a handle [...] that had a piezo tweeter mounted at the focus and firing into the reflector" (Jones 2006a). Sending out a "continuous train of clicks", Jones moved through the space, scanning its surfaces and creating pitched echoes:

Something wonderful occurred. An image of the clicking sound appeared at the other end of the room, but there was also a new sound: a clear, bell-like pitch located right in my ear—a response from the room to the excitation of the sound beam. Slowly moving the loudspeaker to direct the beam around the room, I heard other pitches. Searching in this way, I uncovered a little scale—a set of pitches inherent in the space. The room became a melody instrument.

In this piece, I play the instrument that is this space. Since the phenomenon is position-dependent, each of us will hear his or her own melody, a melody which is a function not only of the room and

my movement, but also of your position in the room. Moving images of the sound should also be apparent.

(CIE 1980b)

John Driscoll had planned to present his *Charmed Particles* as part of Ars Electronica: also an exploration of room acoustics, it was, like Jones' piece, part of the outcome of the NEA grant for work on loudspeakers. The piece is described in the Ars Electronica programme book as incorporating a suspended rotating speaker under the control of a Rockwell AIM-65 microcomputer. *Charmed Particles* was not presented, however, due to lack of funding from the festival to bring the rotating loudspeaker, and Driscoll instead chose to work with his *Ebers & Mole* setup. This was co-performed by Phil Edelstein, who also presented a solo work not listed on the programme: *Terrain*, an open-ended work defined by spatial metaphor. Existing "somewhere between performance and installation", *Terrain* was "a rich topography of sound that the topographer/performer must carefully traverse in order to safely lead the audience through dangerous technical obstacles in a quest for special places of understanding", involving "circuitry that functions as a Zen koan, continually presenting problems that slowly offer solutions to themselves and to myself" (CIE 1980b).

Outside of the CIE performances proper, both Driscoll and Jones presented additional works as part of the competition for the festival's Grosser Preis (Ars Electronica 1980). Jones performed his *Star Networks at the Singing Point*, and Driscoll presented the piece he had developed during the 1978 swimming pool residency in Buffalo, *Bottom Coasting*. Like Jones' *Dry Pool Soundings*, *Bottom Coasting* was an exploration of the resonances of a particular space, by "ringing" the resonances of the space with sine waves, and by use of microphone feedback manipulated by a filter, the cutoff frequency of which changed with the amplitude of the feedback. Driscoll's performance achieved second place in the competition.

Driscoll and Jones' continued explorations of resonance, and Edelstein's use of spatial metaphors for his music, show significant traces of the previous decade or so of work in that area by various other artists and composers. The "science experiment" qualities of Jones' *Dry Pool Soundings* are particularly reminiscent of some of Alvin Lucier's early musical experiments with room acoustics, namely *I am sitting in a room* and *Vespers* (both 1969). In the former, resonant frequencies of a room are revealed by a slow process of acoustic feedback; in the latter, handheld, highly directional speakers are used by performers to navigate a space sonically, reflecting a stream of clicks off its various surfaces. The creation of "ghost images" of sounds produced by reflection and refraction of directed sound waves was also a feature of David Tudor's *Island Eye Island Ear* research, which began in 1974 and was still ongoing in 1980 (Billy Klüver recorded in his *Island Eye Island Ear* notes that the best place to hear Tudor's "beam" of sounds directed at a hill or outcropping of rocks was *behind* the feature (E.A.T. 1977)). CIE's interest in the resonance of rooms, objects and circuits, of course, also directly reflects David Tudor's interests and sensitivities. John Driscoll says that "the strongest thing I felt from working with David was just his profound... he was just so absorbed with the notion of resonance" (Driscoll 2002). Driscoll's *Bottom Coasting* strongly recalls David Tudor's *Microphone*, the 1973 version of which also employed filtered microphone feedback.

Tudor was also an invited artist at Ars Electronica 1980, but was not programmed with, and did not participate as a member of, Composers Inside Electronics (although he was listed in the festival's catalogue as belonging to the group). Since 1966 Tudor had collaborated regularly with electronic music composer and video/laser artist, Lowell Cross, on various projects involving Tudor's sound and Cross's projected images; 1980 marked the last of their collaborations, a tour of Italy and Austria performing a work known as *Video/Laser III*, in a revised version with an improved laser following on the original, dating to 1972. Ars Electronica

was in fact the scene of their last collaboration and final parting, under less than happy circumstances, according to Cross:

Our final venue on this 1980 tour was the Brucknerhaus, Großer Saal, in Linz, Austria for the Festival "Ars Electronica". The Cross Family was well housed, our setup went smoothly, and all seemed in order for our Laser Concert on Wednesday evening, 10 September. I soon discovered, however, that David Tudor had his own "family" meeting him in Linz. I knew nothing in advance about his group, "Composers Inside Electronics", John Driscoll, Philip Edelstein, Ralph Jones, and David Tudor himself. I certainly harbored no ill feelings against his young associates, never having met them before, but it soon became apparent to me that David Tudor was much more concerned with their welfare than with that of the Cross Family. We ended our association. After Nora, Karen, Gregory, and I said good-bye to him on Thursday morning, 11 September 1980 in the presence of his group (he remained silent), we never saw him again. (Cross 2001)

Cross has declined to elaborate on the details of the rupture between himself and Tudor; Phil Edelstein cannot recall what the circumstances were of CIE's interactions with Cross, other than that "I remember an inner excitement and a bit of awe about seeing David and Lowell's work and meeting Lowell" (Edelstein 2006b). Little can be drawn from the available account of the episode besides further confirmation of Tudor's strong bond with "his group".

Final Rainforests of the 1980s

1980 also included two major *Rainforest 4* engagements in Europe, following one on the other in January and February. Both were organisational challenges similar to the 1976 Paris trip, with the exception that these—the first at the Moderna Museet in Stockholm between January 11 and 13, the second at the Akademie der Künste in Berlin between January 20 and February 2 as part of the intermedia exhibition *Für Augen und Ohren*—did not include performances of works other than *Rainforest 4*. The Stockholm performances included Tudor, Driscoll,

Edelstein, Jones and Kalve; the Berlin performances added Viola as well. *Für Augen und Ohren* marked the first use of the title *Rainforest 4* to identify the large-scale group performance version of *Rainforest*; prior to this the piece had been titled simply *Rainforest* on programmes and posters. David Tudor had apparently clarified his vision of the evolution of the work; some uncertainty in numbering the "versions" of the piece is evident between 1973 and 1980. Performances of the *Rainforest* installation which followed in 1981 and 1982 were also made under the title "*Rainforest IV*".

Each multi-day installation in Stockholm and Berlin included many hours of performances, and John Driscoll documented the piece with binaural cassette tape recordings which became the basis for the LP, *Rainforest IV: Berlin Version*. The LP was originated by an invitation from René Block, the curator of *Für Augen und Ohren*, to release a recording of *Rainforest 4* on his independent label, Editions Block. It was eventually issued in 1981 as a collaboration between Editions Block in Europe and Gramavision in the USA (another independent label responsible for issuing many avant-garde jazz recordings as well as recordings by La Monte Young). As part of the contract under which the LP was produced, David Tudor stipulated that both his recording fee of DM1000 and mechanical and performing rights royalties for the record were to be shared equally with the the other five Berlin performers (Performing Artservices 1980). John Driscoll also formally waived any fee for recording the master



Figure 6-27. Left to right: John Driscoll, Ralph Jones, Martin Kalve, Marsha Heather Harris, two unidentified individuals, and David Tudor in Stockholm Airport, Jan, 1980 on the way to Berlin. Photographer unknown, photograph courtesy John Driscoll.



Figure 6-28. Composers Inside Electronics in Berlin, 1980. Left to right: Ralph Jones, David Tudor, Phil Edelstein, Bill Viola, John Driscoll and Martin Kalve. Photograph by Marsha Heather Harris.



Figure 6-29. Composers Inside Electronics in Berlin, 1980. Top: Ralph Jones and John Driscoll, repairing transducers. Bottom: David Tudor with metal strip loudspeaker-object. Photographs by Marsha Heather Harris / Phil Edelstein.



Figure 6-30. Composers Inside Electronics and *Rainforest 4* in Berlin, 1980. From front to back: John Driscoll, Ralph Jones, David Tudor, Martin Kalve. Photograph by Phil Edelstein.

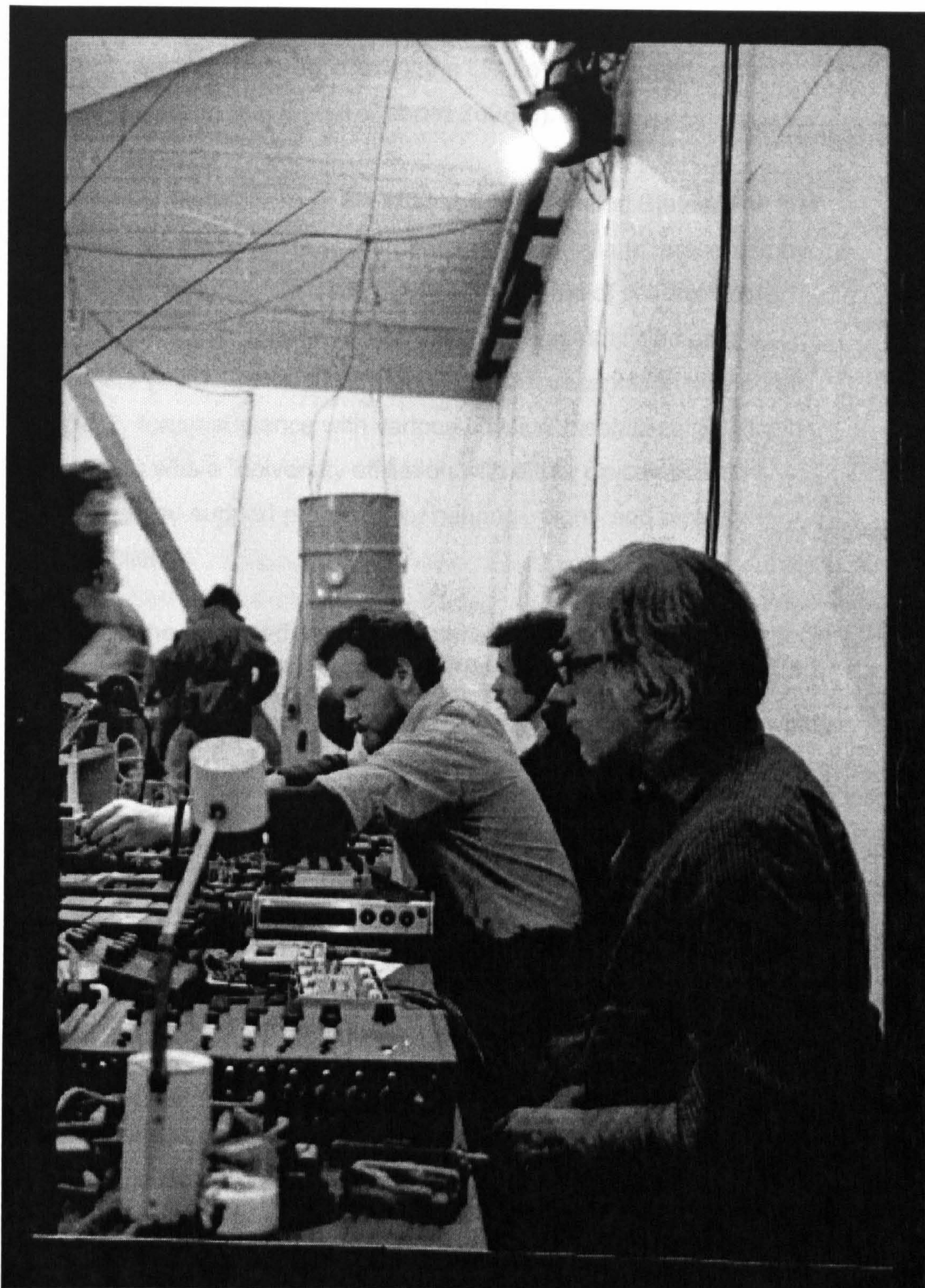

Figure 6-31. Composers Inside Electronics and *Rainforest 4* in Berlin, 1980. From front to back: David Tudor, Ralph Jones, John Driscoll. Photograph by Marsha Heather Harris / Phil Edelstein.

Composers inside Electronics on this occasion included Tudor, Driscoll, Edelstein, Jones, and the addition of Nicolas Collins under the umbrella of the group. Collins had first participated in *Rainforest 4* as a drop-in

tape (according to Driscoll, Block required a quarter-inch, half-track, reel-to-reel master tape for production of the LP, so Driscoll dubbed his cassette original to that format (Driscoll 2006a)).

1981 saw two installations of *Rainforest 4* in the United States. The first was an unusual production at the University of Maryland, presented by John Driscoll and Phil Edelstein only, over a period of several weeks. David Tudor did not participate and the event was not billed as a Composers Inside Electronics production. The presentation was made specifically for an audience with various physical disabilities; Edelstein recalls there was a "university affiliation with either on-campus or campus-related support program" for hearing-, sight- and mobility-impaired clients:

Given the extended nature and some advanced indication of special needs, we probably took some extra care in positioning objects—reasonable heights for wheelchairs, bit of caution on avoiding protuberances and sharp pointy things, making sure wiring was out of the way. Bit of encouragement for people who could hear via bone conduction to bite and listen. Predilection for material that was highly tactile and encouraging feeling the objects. Probably had couple of pairs of mechanics' stethoscopes that we would encourage people to use. These were things we typically did anyway—just maybe with a bit more consciousness for here. (Edelstein 2006c)

Driscoll and Edelstein set the piece up together and performed as a duo for the first few days, and then "switched off operating / babysitting / attending for the duration. Very fond memories of being able to live with the piece for what was probably a month in very pleasant setting" (Edelstein 2006c).

The second *Rainforest 4* of 1981 was a shorter, more typical multi-day installation in a gallery setting, this time the Neuburger Museum at SUNY Purchase, with 19 performances between September 20 and October 4. Composers Inside Electronics on this occasion included Tudor, Driscoll, Edelstein, Jones, and the addition of Nicolas Collins under the umbrella of the group. Collins had first participated in *Rainforest 4* as a drop-in

guest during its 1976 run at l'Éspace Pierre Cardin in Paris, and would participate again in its final presentation before CIE's hiatus, as part of the Holland Festival in Amsterdam in 1982.

The Holland Festival engagement in June 1982 was akin to the 1976 Festival d'Automne in the breadth of work undertaken. Composers Inside Electronics was represented by Tudor, Driscoll, Kalve, Collins, Edelstein, and two performers joining CIE for the first time, Cynthia Black and Takehisa Kosugi. Kosugi was a long-time colleague of Tudor, and CIE had performed his *Catch Wave* as part of its 1976 Paris series. Black, an artist who had experimented with holography before undertaking work with sound synthesis at PASS studios in New York City, had previously collaborated with musicians connected with the "new wave" of pop music, as well as John Cale, formerly of the Velvet Underground and La Monte Young's Theatre of Eternal Music; in 1982 she was collaborating with Phil Edelstein.

Through Performing Artservices, a program was arranged consisting of *Rainforest 4*, Tudor's 1972 work *Untitled*, Nicolas Collins' *Is She Really Going Out With Him?*, John Driscoll's *It's In Them*, and *It's Just Gotta Come Out*, Edelstein and Black's *Papermusic*, Kalve's mobile performance piece, *Baby Maybe Baby?*, and Takehisa Kosugi's *Catch Wave*, which on this occasion incorporated five of his pieces under one title, including the version of *Catch Wave* which CIE had previously performed. One interesting additional piece was proposed for the series, but not realized: a recreation of Tudor's earliest composition *Fluorescent Sound*, originally performed in 1964 at the Moderna Museet in Stockholm, amplifying the small sounds of banks of fluorescent lights flickering on and off. As proposed for the Holland Festival, the piece would have been "expanded from its original solo form to include other performers", with the sounds of the lamps "fed into a processing network" (CIE 1982). To date, the piece has never been recreated.

During the Holland Festival, *Rainforest 4* was presented at the Stedelijk

Museum in Amsterdam between June 5 and 13, with daily performances lasting two hours. The piece was presented in the context of an exhibition entitled *'60-'80: attitudes/concepts/images; a selection from twenty years of visual arts*, with all seven performers taking part in its performance.

Takehisa Kosugi's *Catch Wave*, performed by Black, Collins, Kalve and Kosugi, incorporated five earlier works, reaching back to his Fluxus-era pieces. The earliest of these was *Micro 1*, a 1964 text piece instructing the player to "Wrap a live microphone with a very large sheet of paper. Make a light bundle. Keep the microphone live for another 5 minutes". The initially loud action of bundling the microphone leads to a long period of quiet sounds as the paper unfolds. Another Fluxus-era process piece, *Anima 7* (also from 1964), instructs the performer to perform any action "as slowly as possible". The other works incorporated into CIE's performance included *m g* (1966), described as consisting of high and low frequencies entering and disappearing gradually; *Numbers/Tones* (1976), an exploration of sounds relating to the 88 keys of the piano; and *Catch Wave* proper, in a version from 1967.

Catch Wave was presented on June 4 at Centrum 't Hoogt in Utrecht, along with Martin Kalve's *Baby Maybe Baby?*, a peripatetic sound sculpture involving a pram equipped with light-responsive sound generators and amplification system. Sounds changed as the pram moved, or as people moved around the pram; the piece was also presented in Amsterdam on June 7 and 9 in the foyer of the Theatre Bellevue.

John Driscoll's *It's In Them...*, a "softer, silent" piece (Driscoll 2002), employed ultrasonic transposition techniques to reveal hidden sounds of "miniscule movement" of objects: in Driscoll's description, "This work has grown out of a fascination with small movements creating their own music with nudges and tender encouragement by the composer. Somewhere, in the back of my mind, I see hundreds of these gesticulating little instruments asking to be heard" (CIE 1982).

Nicolas Collins' solo performance of *Is She Really Going Out With Him?* (later known as *Is She/He Really Going Out With Him/Her/Them?*) was based on a homemade "automated mixer" inspired by early turntable cutting between beat-matched sources. Collins' circuit accepted many inputs, and a microprocessor automatically mixed the input signals based on "rhythmic coincidences":

I thought, two record players, what if you had more? I thought it would be wonderful to have a wide open thing, ten, twelve, twenty channels, where any time two things came into rhythmic coincidence they would crossfade. The idea was that I'd keep developing other sound material to feed into it. The performances consisted of just plugging and unplugging sixteen inputs, electronic toys, tape loops, radio, musicians, whatever. (Collins 1995)

Collins and Driscoll performed their pieces on June 7 at the Theatre Bellevue in Amsterdam, with Kosugi and Tudor participating in the performance of Driscoll's work.

A second evening at Theatre Bellevue on June 9 included David Tudor's solo performance of *Untitled* and Cynthia Black and Phil Edelstein's *Papermusic*, performed by the duo. *Papermusic* was another in the series of works by CIE members which directly stemmed from *Rainforest*: its instruments were handmade, molded paper panels, approximately 4 by 8 feet, with embedded transducers and piezo microphones, which were suspended above the audience.

[...] we had this idea of imbedding electronics in paper. [Cynthia] was doing cast paperwork. The version we did for Amsterdam...we wound up taking cast sheets—was that really the right term? It was essentially very, very large sheets of handmade paper, but without compression. So the material we were working with here was almost more like a paper maché, somewhere before the manufacturing process, before you run it through a set of rollers to compress it and get it really thin. And we had a series of instruments, a combination of set pieces and instruments where we were embedding mostly piezo, but it didn't work very well.

[...]

it was the intersection of trying to find that balance of distributing sound and space...kind of a next generation of...not *Rainforest*

objects, but the parallels were very, very strong, right? I mean you had, essentially, another way of building a specialized loudspeaker. So the paper objects were a class of specialized loudspeakers. (Edelstein 2002)

Edelstein described the focus on paper as not only a means of experimenting with *Rainforest's* concepts beyond the boundaries of *Rainforest*, but also "trying to get a better masculine/feminine balance" in the context of CIE's "heavy metal" *Rainforests* (Edelstein 2002). An earlier version of the paper sculptures included autonomous soundmaking circuits embedded as well. In Amsterdam, Edelstein employed the sculptures' transducers and pickups in combination with conventional loudspeakers, to create feedback networks:

I was doing a lot of work with these notch VCAs with very sharp attacks. I had an envelope and I was building these rhythms with these things. So these would be in the order of rhythm sense. So what I would do, on one pulse emit a sound and on the other pulse, open up a mic. And this would be in the same order of magnitude of the propagation time between the microphone. The basic idea was that you would emit a sound here and then you would listen for it here and you'd use this as a signal to another loudspeaker. So you would excite the space and then use that excitation in another discrete time series and build up rhythms and complex feedback loops with that. [...] you would take a signal, and send it to the speaker here, pick up on the microphone over here time-wise, some artifact of that, based on the propagation time across the space, and then play that in the loudspeaker. And the performance challenge for me was the balancing of these two—how do you make both of these elements work? [You don't get acoustic feedback, because of ...] the time separation" (Edelstein 2002).

Prior to the Amsterdam performance, some of the sculptural paper loudspeakers were shown at PASS (Public Access Synthesizer Studio) and a private gallery in New York City, but Edelstein says that ultimately he was "very undecided about it. I'm not sure it worked. And it certainly didn't work to the extent that it didn't go on [beyond 1982]" (Edelstein 2002).

The 1982 Stedelijk Museum installation of *Rainforest 4* was the last which Discreet Inside Electronics presented during David Tudor's lifetime, neither was the name of the group used as an umbrella for any further events until *Rainforest 4* was revisited in 1996. Various members of the group continued to work together and present concerts, however, John Driscoll and Linda Dowling Cunn at Cornell University in 1996 a series of performances performing Tudor's *god's come out* territory by the 1970s, and *Rainforest 4* by Tudor and Taha. The exhibits of David Tudor were outside CIE; the *Rainforest 4* project creative energy creative work in this



Figure 6-32. *Papermusic* instrument with embedded transducer and piezo pickup, by Cynthia Black and Phil Edelstein. Photo courtesy Phil Edelstein.

The 1982 Stedelijk Museum installation of *Rainforest 4* was the last which Composers Inside Electronics presented during David Tudor's lifetime; neither was the name of the group used as an umbrella for any further events until *Rainforest 4* was revisited in 1996. Various members of the group continued to work together and present concerts, however: John Driscoll and Linda Fisher were both associated with choreographer Douglas Dunn and co-presented an evening of their work at Cornell University in 1983; also in 1983, Driscoll and Tudor shared an evening in a series presented by Artservices in New York City, with both musicians performing Tudor's *Dialects (No. 2)* and Driscoll's *It's in them and it's just gotta come out (duet)*. The dance *RainForest* was brought back into repertory by the Merce Cunningham Dance Company between 1988 and 1990, and *Rainforest 1* was performed 59 times during that period by Tudor and Takehisa Kosugi.

The members of Composers Inside Electronics who gathered around David Tudor were all emerging independent artists with active careers outside CIE; throughout the approximately nine-year span of initial *Rainforest 4* presentations, CIE was just one of the outlets for their creative energies, and David Tudor was only one of the stimuli for their creative activities. There was an egalitarian aesthetic at work in this "group of changing membership" (Stedelijk Museum 1982, 217), but it is clear that David Tudor regarded CIE with some pride as "his" group, and that he functioned in the role of mentor to the younger artists, to a greater or lesser degree. This is apparent not only from the archived correspondence from the younger CIE members to Tudor, in which they frequently express appreciation bordering on adoration for the opportunity to work with him, and enumerate the ways in which their personal and professional lives have been enriched by the experience; this appreciation is also evident in the many interviews which I conducted with CIE's original core members, all of which brought out Tudor's complex personality, and the enjoyment and occasional frustration of working with him. In Phil Edelstein's words, Tudor was "the master of simply not saying

very much on various topics and yet being completely engaging" (Edelstein 2006b).

The core members' 1973 encounter with Tudor and *Rainforest* at the New Music in New Hampshire workshops occurred at a formative time in their lives; all were in their early 20s and just beginning to seek careers in music, sound and what came to be called "media arts". The resonance of *Rainforest* can be detected with little difficulty in works which Driscoll, Edelstein, Fisher, Jones, Kalve and Viola created through the 1970s and into the 1980s; and beyond echoes of *Rainforest*, there are also strong reflections in many CIE members' works, of other aspects of Tudor's practice, particularly his use of acoustic and electronic feedback.

"Composers Inside Electronics" functioned as an umbrella for a group of artists who, to a large degree, shared a common interest with David Tudor in obtaining mastery over the intricacies of contemporary electronics. Although most developed at least some facility with circuit design and building, none came from an engineering background. In 1973, the integrated circuit was still a relatively recent development; analog hardware could be miniaturised to a degree which would have been impossible only ten years previously. To a certain extent, CIE was driven by these new technologies and the possibilities inherent in them, and by a "boy-hobbyist" enthusiasm.

Rainforest 4 was, in Ralph Jones' words, "the star around which we all orbited" (Jones 2001). Looking back on the piece after Tudor's death in 1996, Jones wrote:

With "Rainforest IV", David Tudor showed us a truly collaborative, egalitarian way of working that allowed each contributor maximum freedom of creative action yet, miraculously, resulted in a work that always retained its integrity and identity. Before experiencing "Rainforest", I doubt that I would have thought such a thing to be possible. Its very nature, seductively beautiful and unforgettable, and its aesthetic strength, as fresh and modern today as it was over twenty years ago, are the direct result of David's incredible generosity of spirit. I ate at his table many times, stayed at his

home, traveled the world with him and learned more from him than I can possibly express. He changed my life. I still encounter him in my dreams. To say that I will always love and never forget this remarkable human being does not begin to tell the story.

The fact that *Rainforest 4* retains its identity from performance to performance, despite significant variation in the number and type of loudspeaker-objects employed, and the number and sonic resources of its musicians, is quite remarkable. Martin Kalve also noted this in early 1977, writing that "Despite the independent growth and development that the individual players have enjoyed, some having joined the performance in July, 1973, some joining as recently as October, 1976, *Rainforest* has maintained a unique and consistent identity and ecology" (Kalve 1977).

The "collaborative, egalitarian" working methods behind *Rainforest 4*'s creation and continued production include a strong component of self-regulation, however, which explains much about the conservation of its sonic identity. For instance, even as new musicians are invited to take part, bringing the potential for a disruption in the piece, those musicians are first of all invited because their work, and temperament, is known to the group; the process of "fitting into" *Rainforest 4* then also involves, to some degree, an oral communication of the ideals of the piece. The "wisdom" of those who have previously performed it—much of that simply practical knowledge acquired by trial and error—is available to newcomers, should they require it. Where the potential for disruption becomes a reality is when concern for the overall stability of this "electroacoustic ecology" is overridden by performative enthusiasm: As David Tudor acknowledged, the performers could "get so carried away with the fireworks that can happen in the sculpture itself that they don't pay attention to the tonal balance." (Tudor 1988a).

Some of the aspects of self-regulation within *Rainforest 4* and *Composers Inside Electronics* became clearer to me as I became involved as a participant-observer in the piece and the group, following David Tudor's

death. The final chapter of this thesis will consider how a younger generation of performers has become involved in the continuation of *Rainforest 4*, invited into the "changing membership" of CIE as a means of sustaining the "star" around which the group orbits.

Chapter 7

AFTER DAVID TUDOR: THE FUTURE OF *RAINFOREST* AND COMPOSERS INSIDE ELECTRONICS

David Tudor died in the early morning of August 13, 1996, four years and an hour and a half after his longtime associate and music experimenter, John Cage, had died, also of a sudden fatal stroke.

Larry Austin
(Austin 1996)

[...] we were talking earlier about how they treated *Rainforest* as a museum object. They also treated the group as though it were. As though it were something that had been fixed in time in 1973, for god's sake. But it isn't like that and *Rainforest* isn't like that. [...] Then this question becomes, going into the future you know, should you and John and the new people coming into it keep that name. And obviously it's not for us to decide, it's for you to decide [laughs]. You get to figure it out. At least for my opinion, you certainly have the option.

Ralph Jones
(Jones 2001)

Composers Inside Electronics:

Remembering David Tudor through *Rainforest 4*

Although from 1982 until the end of his life David Tudor did not again perform *Rainforest 4*, his schedule was as continuously busy as ever. While continually taking on new projects, he remained associated with the Merce Cunningham Dance Company as a musician and composer, and after John Cage's death in 1992 became the Company's Musical Director. As mentioned in the previous chapter, Merce Cunningham revived his dance *RainForest* in 1988 and Tudor again performed the small-scale version of the piece on numerous occasions, as a duo with Takehisa Kosugi (who a few years later became Musical Director of the Cunningham Company in 1995 as Tudor's failing health prevented him from touring).

Composers Inside Electronics, formed around *Rainforest 4* and operating as a pool of similarly-minded musicians exploring the potential of new technologies, had existed as a "family", but one seemingly without a lasting cohesion. Its disuse as an umbrella for its members' activities following the 1982 Holland Festival has been attributed to simple exhaustion with the rigours and planning of touring *Rainforest 4*, combined with the burgeoning careers of its membership which made it less likely that they would be available for performing the piece. Much as the group was never formally organised, it was never disbanded; it seems simply to have served its purpose during the years 1976 to 1982 and at that point was set aside in favour of other ventures. As previously mentioned, its members continued to collaborate from time to time, but were busier with their individual projects.

On September 17 1996, a little more than a month after David Tudor's death, a memorial celebration was organised at the Judson Church, near Washington Square in New York City. As part of the event, Composers Inside Electronics was called upon to commemorate Tudor's life with a performance of *Rainforest 4*. Various *Rainforest* objects which had not

been seen or heard from in more than ten years—some of which dated back to the 1973 workshop—were retrieved by members of CIE from a shed at Tudor's Stony Point house, a self-storage unit in Pomona, New Jersey, and John Driscoll's home garage. Driven into Manhattan and carried into the Judson Church, primarily by Phil Edelstein and John Driscoll, they were quickly strung up in a somewhat haphazard manner on the day of the memorial. Of the original performers, those present were Driscoll, Edelstein, Paul DeMarinis, Linda Fisher, Ralph Jones and Bill Viola. Russell Frehling, who had participated in the only outdoor performance of *Rainforest 4* in 1978, also joined the group. Martin Kalve was expected to join the performance but did not, although he was in attendance that evening. The performance was billed simply as *Rainforest* in the memorial celebration's programme.

Uncredited in the programme, two much younger musicians also joined in the performance: John D.S. Adams and D'Arcy Philip Gray, both Canadians who had worked with Tudor for several years in the context of the Merce Cunningham Dance Company. Adams' association with Tudor began in 1992 as the Company's sound engineer; this evolved over four years into a parallel role as musician, with Adams taking on more elaborate performance duties as Tudor became increasingly incapacitated, which extended to performing in Tudor's place when he was unable to tour with the Company (Rogalsky 1995, 42-43). Gray, a classically-trained percussionist, first performed alongside Tudor in 1992 as part of a memorial event for John Cage, and in 1993 was invited by Tudor to join the Cunningham Company: "extremely daunting at first as I struggled to manipulate a complex analog processing system; I soon realized that I had to learn the techniques of his instruments, much like one would learn how to play the violin or the piano" (Gray 2002). Since David Tudor's death, both Adams and Gray have put significant effort into maintaining and performing existing Tudor works from the 1990s such as *Soundings: Ocean Diary* and *Neural Network Plus*, while also revisiting under-documented, older Tudor pieces.

The performance of *Rainforest 4* at Tudor's memorial was fairly *ad hoc*; Linda Fisher recalled that after the objects were suspended from available fixtures, "we just sort of plugged in, I think, and we played whatever ones happened to be there". Despite the casual nature of the event—more of an occasion for meeting old friends and reminiscing about Tudor, than a focused performance—Fisher says "It felt pretty full-fledged to me [...] coming back to it out of the blue that way". Her last performance of *Rainforest 4* had been in 1976; after a twenty-year break, her questions to herself were: "Did I have objects? What did we do? What did I use?" (Fisher 2003).

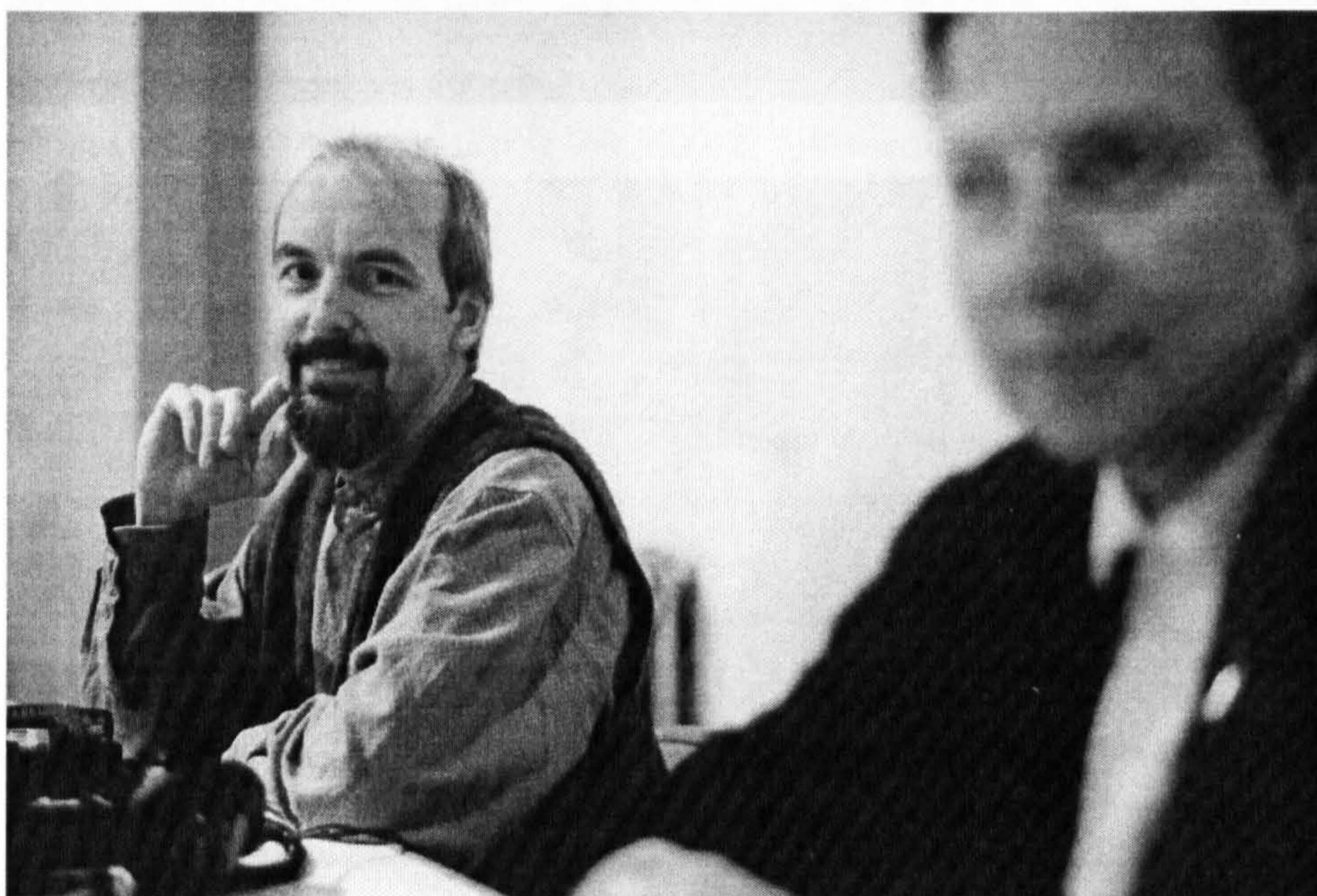

Figure 7-1. Bill Viola and Linda Fisher preparing for the *Rainforest* performance at David Tudor's memorial celebration, September 17 1996, Judson Memorial Church, New York City. Photograph by Matt Rogalsky.



Figure 7-2. Preparing for performance of *Rainforest 4* at David Tudor's memorial celebration, September 17 1996, Judson Memorial Church New York City. Top: Ralph Jones and John DS Adams. Bottom: Russell Frehling and D'Arcy Philip Gray (foreground), John Driscoll, Bill Viola, Linda Fisher, unknown (background). Photographs by Matt Rogalsky.

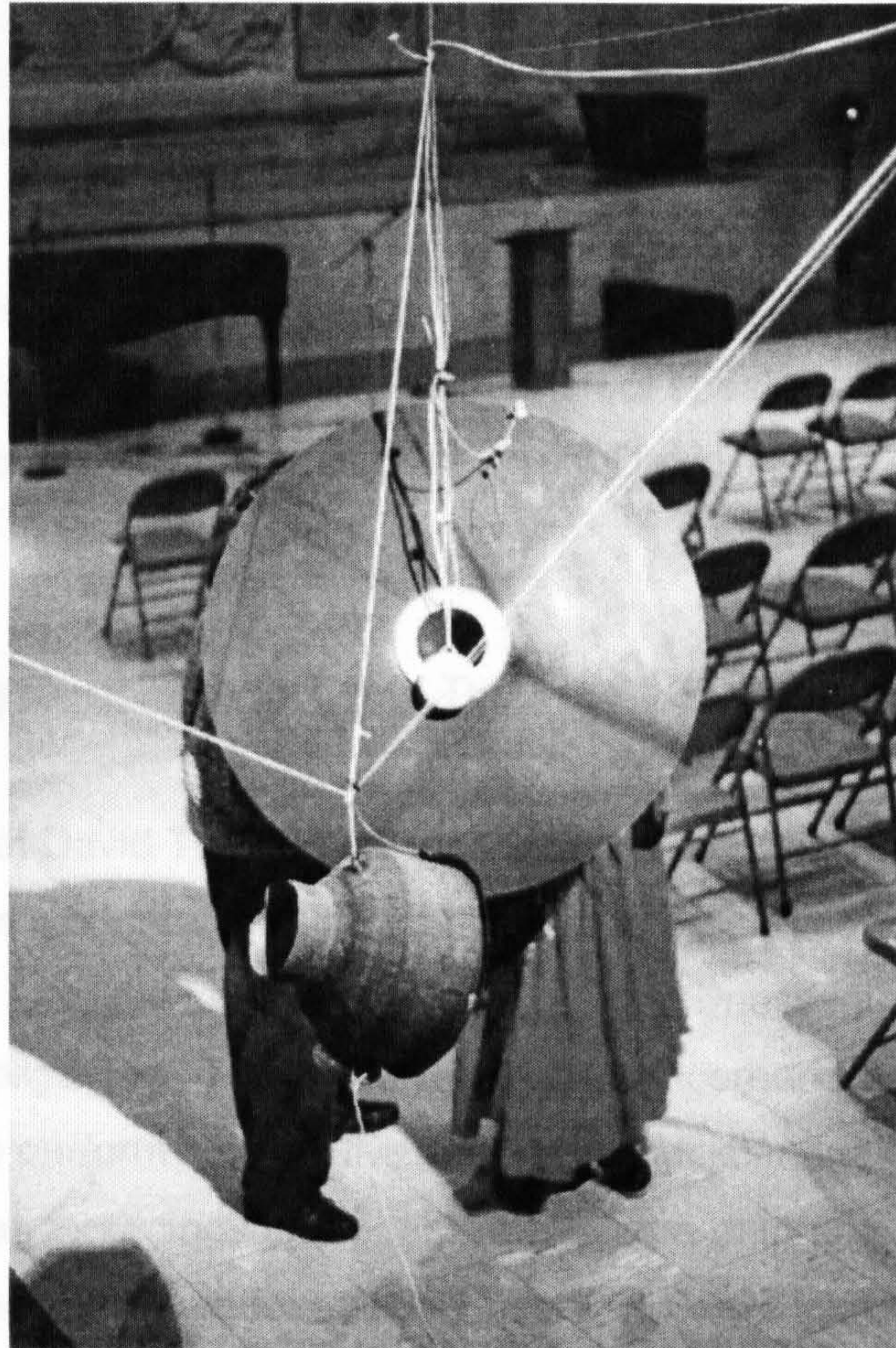

Figure 7-3. Two listeners hidden by resonating vintage hard disk, during preparations for performance of *Rainforest* at David Tudor's memorial celebration, September 17 1996, Judson Memorial Church New York City. Photograph by Matt Rogalsky.

Musicologist David Patterson wrote an account of Tudor's memorial celebration which included a description of CIE's activity:

Tudor's sound installation "*Rainforest IV*" was on display in the sanctuary itself. In the four corners of the room, technician-performers manipulated electronic equipment, sending impulses through approximately 18 transducers, each attached to one of the found objects that were suspended from the ceiling and circled the sanctuary, thereby setting each into audible vibration. The objects in this particular installation included a rusted metal jug and two sawed-off wooden organ pipes; other objects were less identifiable. The most popular object seemed to be an overturned metal barrel, and more than one adventurous soul actually stood within the barrel itself, effectively covering the whole top halves of their bodies to enjoy the vibrations in surround-sound. Some of the sanctuary windows were open, and several commented on the sounds that

they had heard spilling out onto the streets as they approached the church. Over the course of the next two hours, the sound of Tudor's installation evolved in a continuous forte as the audience arrived. (Patterson 1997)

During the celebration, Bill Viola represented Composers Inside Electronics, appearing last in the succession of speakers who gave their personal accounts of working and living with David Tudor.

David Tudor's music, without David Tudor

The passing of David Tudor occasioned much discussion of how to perpetuate his work, much of which seemed to be unrecoverable as live performance. Until the final year of his life, when illness interfered with his performing obligations, Tudor had been little concerned with teaching others how to perform his solo live electronic music; many earlier pieces existed only as recordings and generalized score diagrams, which in theory showed his setups for specific pieces but were little help in reconstructing which specific devices were used, or how. In addition, much of the technology originally used had itself vanished, or was simply unidentifiable. David Behrman commented in 1998 that

There is a paradox in the legacy of David Tudor: the wonderful quality of his work in electronic music was due in part to his use of quirky, homemade circuitry, the inner workings of which he was slow to divulge to his assistants and colleagues. Yet that quirkiness, which made the music so good, also made it evanescent. It could only exist for a few years before being swept away by the torrent of technological change. [...] we've had the heartbreaking experience of trying to understand his no-longer-working, unlabeled circuitry and of coming to the realization that there was no way to revive that music in a literal sense. (Behrman and Kuivila 1998)

This "heartbreak" was experienced by anyone surveying the hundreds of electronic components, many homemade, which constituted Tudor's

instrument collection as deposited by his estate with Wesleyan University's World Instrument Collection.

Ron Kuivila noted that partly due to Tudor's viewpoint that "configuration defines the identity of the composition", in most of Tudor's music it was "very difficult to distinguish performance from composition". Kuivila's tactic in recreating Tudor works such as those associated with the 1970 Pepsi Pavilion (better documented than most) was then

[...] not to reconstruct the continuity of his pieces—that is inextricably intertwined with his own unique sensibility. Instead, it is to reconstruct the "moves"—the set of musical questions—that the pieces create. (Behrman and Kuivila 1998)

At the same time that Kuivila was recreating some of Tudor's analog electronic works using new digital technologies, modeling his use of specific sound processors in software, I took an approach to studying and performing Tudor's music unavailable to most musicians and scholars. Jumping through the horns of the dual dilemma of under-documentation and lack of original instrumentation, I located and was able to gain access to the only extant "Tudor table" representing a specific composition from a specific period, as commissioned and preserved in its entirety by UK collectors Adam and Carolyn Barker-Mill. My experimentation with the table, a 1990 piece entitled *Virtual Focus* which Tudor created in collaboration with Jacqueline Matisse Monnier, has been documented elsewhere (Rogalsky 1999); in short, it was a unique and challenging experience to work directly with the table as set out by Tudor, and to attempt to learn more about his musical practice as defined by this particular arrangement of variables.

The challenges of continuing to keep Tudor's music a "living" enterprise were significant where many of his solo works were concerned, due to the lack of information regarding their performance; this was not so much a problem with the *Rainforest* series, however, especially *Rainforest 4*

with its wide variation in possible performance strategies, and large contingent of participants familiar with its realisation. The challenge in the case of *Rainforest 4* was more a question of how the older generation of Composers Inside Electronics might, after such a long break from the piece, in some way "officially" transmit it to a younger generation of musicians, conveying to them what they felt to be the most meaningful aspects of their knowledge of the piece. The involvement of John D.S. Adams and D'Arcy Philip Gray with the memorial celebration performance was a first gesture in this direction.

Rainforest 5: a first attempt to formulate new directions

Shortly after Tudor's memorial celebration, John Driscoll drafted a proposal for a *Rainforest 5*, which was submitted on behalf of CIE to the relatively new media arts center Thundergulch, a project of the Lower Manhattan Cultural Council located in the financial district of New York City. Thundergulch, now defunct, was at the time an exciting resource, funding innovative media arts projects. *Rainforest 5* was framed as such:

The proposed project involves creating a new version of a well known sound environment titled *Rainforest IV* [...] Following David Tudor's recent death it was decided by Composers Inside Electronics that the work should be continued due to interest in a permanent installation expressed by both the Whitney Museum of Modern Art and separately the DeMenil family.
(CIE 1996)

How committed the Whitney and the DeMenil family (well-known patrons of the arts) actually were to the project is unclear. The proposal was formulated as a four-month collaborative project involving Composers Inside Electronics (John Driscoll and Ralph Jones), Thundergulch, Harvestworks (the new media public access studio in New York City, with Phil Edelstein as a board member, which offered computer resources) and Wesleyan University (with Ron Kuivila designing a web interface and

managing a remote testing site there). Three main steps were identified for the project, the first being "Automation" ("transforming" the work "to use automated sound sources vs. performers"), the second "Remote Access" (creating a version which "allows for simultaneous visitors at the installation site, as well as remote visitors via RealAudio random access audio on the internet"), and the third "Continuous Use Issues" ("Redesign the physical aspects of the work to allow for more robust design of the sculptural objects, and electronic sub-systems to withstand 24 hour use, and ease of maintenance"). The research project was proposed to be carried out at the Thundergulch building at 55 Broad St. in New York City.

This proposal for "*Rainforest 5*" envisioned a version of the existing installation *Rainforest 4*, with the modification that all sound sources would be prerecorded and played from a library of CDs. No mention is made in the proposal of any live performance aspect, and is in fact specifically excluded: "automated sound sources vs. performers". This would have represented a surprising departure from all prior versions of *Rainforest*, and in fact the live performance element has always been deemed of central importance in subsequent discussions of what forms a "*Rainforest 5*" might take.

The Thundergulch proposal was therefore a simple, but radical revisioning of *Rainforest*. While performative aspects of the piece would be removed, the proposal argued that the piece's audience would be greatly enlarged via accessibility by "remote visitors" in addition to those able to attend the physical installation. The proposal called for "Design of a web site with binaural audio (3D audio), and selection of sound channels from each object pickup with feeds over ISDN and T1 lines" (CIE 1996). This would mean the remote visitor would be able to experience the work as a whole, presumably from one or more perspectives via binaural pairs of conventional air microphones, but also would be able to "zoom in" on single objects, listening to direct signals from their contact microphones individually.

We should remember that at the time this project was proposed, delivery of live media over the Internet was still a novelty, and high-quality audio streams frequently taxed the bandwidth and processing capabilities of the average home computer. Most home computer users, if they were connected to the Internet at all, were doing so by modem, with a maximum (and rarely achieved) data transfer speed of 56k. The technologies required for this *Rainforest 5* project were not as trivial a matter as they might be today (in 2006). Unfortunately, Thundergulch was not enticed into funding Driscoll's application, and the envisioned project was not pursued.

Further attempts to define a *Rainforest 5*.

Two years later, another attempt was made to focus CIE's thoughts on what might constitute *Rainforest 5*, when Composers Inside Electronics presented another major public installation of *Rainforest 4* at the Clark Studio Theatre in New York City as part of the Lincoln Center Festival between July 15 and 19, 1998. The original group was well-represented, by Paul DeMarinis, John Driscoll, Phil Edelstein, Linda Fisher, and Ralph Jones. According to CIE's programme notes,

The group was re-formed in 1996 to do *Rainforest IV* at Judson Church in New York City for David Tudor's memorial service. It decided to continue its work with a focus on both training younger composer/performers in the *Rainforest IV* work and creating a new *Rainforest V* version for permanent installation. (CIE 1998)

The emphasis on "training" some younger players is of some interest; we can recall that Tudor himself stated that "Very little instruction is necessary for the piece. I've found it to be almost self-teaching because you discover how to program the devices by seeing what they like to accept" (Tudor 1988b). On the occasion of this first major *Rainforest 4* installation after Tudor's passing, additional composer/performers invited to perform as part of Composers Inside Electronics included Ron Kuivila, Ben Manley, John D.S. Adams, D'Arcy Philip Gray and myself. With the

exception of Ben Manley, a New York-based experimental music performer who had formerly studied with Alvin Lucier, and developed a table-top electronics practice related to Tudor's approach, all of the rest had some previous direct experience with performance of various versions of *Rainforest*, and other Tudor works.

The sort of "training" which was on offer for this group of younger performers—none of whom were actually very young—was obviously not intended to be of the most basic, technical sort; the primary nature of the "training" involved might be best described as a process of bringing new performers into the social network, and through the experience of realising *Rainforest 4* and interacting with those who worked directly with Tudor on the piece, offering an "education" in CIE's practice of his "electroacoustic environment".

This functioned as a sort of apprenticeship: if some of the new performers' actions were ungainly, *Rainforest 4* as a group activity "had enough grace in it" (borrowing from Paul DeMarinis' words) to absorb that ungainliness and allow almost any number of "second chances". The question remained as to what sounds might be appropriate when all sounds are apparently permitted per Tudor's original instructions forbidding only "composed musics" (Tudor 1980); the more difficult question might be to ask what sounds are *inappropriate*. In the Lincoln Center staging of *Rainforest 4*, "junior" performers were deliberately paired at tables with original members of Composers Inside Electronics, with the clear concept that the experienced performer would provide guidance when needed, on this matter and others, to help integrate the newcomer.

Manley, coming to the piece as a completely new experience, had some difficulties with its technical limitations which he discovered by trial and error: he recalled discovering that one of his objects, a "sand blade", was not responding as he felt it should; it became clear that the reason for this was that it had a central transducer mounting point which was insulated

from the resonant parts of the object by a rubber gasket. Manley also discovered that broad-band sound materials such as pink noise, which he often used in his own work with heavy-duty "bass shaker" transducers intended for car stereo systems, were not suitable for the lighter *Rainforest* type: "I burned out two, maybe three transducers", he recalled, before coming to the realisation that "what works best for *Rainforest* is to find specific frequencies. Brute force [broad-band sound material played at a significant amplitude] is not the best approach" (Manley 2006).

Rainforest 4 as presented at Lincoln Center in 1998 was one of the largest-ever installations of the piece, and by all accounts one of the most dramatic. Ten performers, each with four hanging loudspeaker-objects, occupied tables around the perimeter of a large black-box theatre, darkened except for spotlights illuminating the objects themselves, with lighting design by Beverly Emmons, formerly of the Merce Cunningham Dance Company. The tightly focused lighting allowed the dozens of cables suspending the objects, bringing signals to them, and returning from each of their contact microphones, to fade into the background, eliminating the "messy" appearance of many previous *Rainforest 4* installations which depended on more general lighting. Linda Fisher recalled that the overall presentation at Lincoln Center was as compelling as, if not more so than, any previous installation, with an extraordinary final outcome after 24 hours of performance over four days:

I think back about it and I think sometimes in the moment it is harder to see it because you haven't had the benefit of history—of your own history and looking back and seeing what actually happened with the piece over the years and how it just retained its integrity to the very end. I mean, it was as live and vibrant, you know, the last time even more than the first time. You remember that last performance at Lincoln Center. I mean, that was astounding. (Fisher 2003)

With the Lincoln Center installation, one of the changes in the performance of *Rainforest 4* was the first appearance of computers as sound generators or simply as playback devices. Fisher herself used a

laptop as one of her primary resources: "the thing about Lincoln Center to me that was so new was all the computers. And, you know, I had one too. I was pulling my sounds off my hard drive and routing them out, but it was different. It didn't have that funky look that we used to have" (Fisher 2003). The "funky look" of the musicians' tables is certainly diminished when many performers have in front of them computers which on the surface look identical; Fisher observed, however, that there was a certain amount of sameness in players' setups in the past as well: "It used to be that we had the same mixers because there weren't that many commercial products that we liked to get. But when we found one that was good and worked for us, then everyone would get it" (Fisher 2003).

The surface sameness of computers, and the use of MIDI devices (in the setups of Ron Kuivila and myself), seemed to be an obstacle not so much for members of the original group, but rather for some of the younger set: I recall Adams and Gray, attached to Tudor's "analog aesthetic" as an ideal, poking gentle fun at the presence of digital equipment. This conservatism surprised me; from my point of view, these computers and MIDI controllers were like a blank slate, each performer using them for his or her own sonic ends. Although in using computers there was more apparent uniformity of instrumentation, there was no commonality of approach. Linda Fisher approached the computer essentially as a convenient means of storing and playing back a large number of soundfiles. Paul DeMarinis steered away from sampled sounds and used the graphical programming environment Max to create "lots of oscillators, kind of like long chains of oscillators doing funny things to each other" (DeMarinis 2001). Ron Kuivila used original software which allowed morphing between presets using a graphics pen, plus a MIDI keyboard used as a bank of switches, rather than for any more conventional musical purpose.

Besides the emergence of computers as a primary resource, there was still a substantial presence of homebuilt analog equipment: Phil Edelstein revived circuits he had designed for his pieces of the 1980s (Figure 7-5);

Ralph Jones made *Star Networks*-style feedback circuits by interconnecting miscellaneous passive components, four tube preamplifiers, and a 6x4 summing amplifier with the ability to switch the polarity of its outputs. Prerecorded material was still important as well: John Driscoll relied heavily on his library of recordings, no longer on cassette but instead played from CD.

Another technological modification involved the type of contact microphones employed to amplify each object's resonances through the conventional PA system. Previously, Tudor and his co-performers had primarily used 1960s-vintage phonograph cartridges for this purpose, replacing the cartridge needle with a stiff piece of wire which could be attached to the body of the object. This linked *Rainforest* conceptually, in a most straightforward way, with Cage's *Cartridge Music* (1960), which employed phonograph cartridges in the same manner. Almost 40 years after *Cartridge Music*, this style of cartridge was obsolescent, and not readily available; some of the original *Rainforest 4* performers had their own small supply, and Tudor's instrument collection as deposited with Wesleyan University included a cache of used and brand-new cartridges, but there did not seem to be enough to go around. I decided to use more commonly available piezoelectric discs on my four objects instead; these were considered by John Driscoll and others to give a less rich response than the old cartridges, particularly in the low frequency range, but I found that I could compensate for this somewhat by equalising the signals returning from the objects.

Rainforesting: some personal notes

My experience of joining with Composers Inside Electronics in a first "real" presentation of *Rainforest 4* was aided immeasurably by having worked on the piece in less ambitious versions with undergraduate students at Wesleyan University (Rogalsky 1995). I had also acquired a number of transducers with which I could "rehearse" at home. Ultimately I

felt that if I had a wide range of source materials, and the ability to fine-tune the equalisation of those sources, I would be able to come into the Lincoln Center performance and work with whatever objects were available to me.

My own setup employed patches I had written in the SuperCollider programming language (version 1.0) to build textures from source material consisting mostly of field recordings which were manipulated with simple techniques such as playback speed changes, and amplitude and frequency modulation. In addition I brought a feedback instrument I had made by combining a uniquely programmable digital multi-effects device with a MIDI controller, modelling some of Tudor's "no-input" electronic feedback experiments of the early 1970s (Rogalsky 2002). I also had a large collection of prepared source materials (also based on original and "found" field recordings) on CD, and two CD players. My four loudspeaker-objects, which I decided upon only after arriving at the Clark Studio Theatre, included a large-diameter hard disk, a small, heavy stainless steel container (both objects brought out of storage from the previous era of *Rainforest 4* performances), an eight-foot aluminum ladder, hung at an angle off the floor, and a battered old suitcase of David Tudor's, identified by a handwritten luggage tag bearing his Stony Point address (all these objects may be seen in the first few panels of the panoramic image in Figure 7-7).

I felt it was important and useful to me, as a "student" of the piece, and as a participant-observer wishing to document *Rainforest* and the functioning of *Composers Inside Electronics*, to be involved from the earliest stages of production. I had assisted in 1996 with bringing the original *Rainforest* objects out of storage for the Judson Church event; at Lincoln Center I made sure to arrive at an early stage, to help load in equipment and observe the process of planning the installation (some views of which are shown in Figure 7-4). Linda Fisher has mentioned that in performances of the 1970s, decisions frequently had to be made about distribution of available sound reinforcement equipment of variable quality, with the

outcome that some CIE members had typically to make do with poorer PA equipment for the "reflected sounds" coming from the object pickups (Fisher 2003). This was not an issue at Lincoln Center due to uniformly excellent sound reinforcement, and John Driscoll later commented that the reinforcement speakers were only lightly used, due to the sonic presence of the objects themselves, as well as performers' sensitivities to the "collective sound space" (Driscoll 1998).

Decisions about location of the approximately 40 objects were made collectively, as were choices of which to use. Many of the prosaic "found object" types were "original" to the piece, either retained from the 1973 workshop or added in the years between then and 1982: Phil Edelstein's strip of copper sheet metal, large and small wagon wheel rims, the steel shield-shaped lid, the large hard disk, the copper still, and the large wooden organ pipe. Others were included based on objects which had formerly appeared in *Rainforest 4*: small circular plastic water sprinklers, the inverted oil drum. Some other prosaic objects were brand new to the piece: Tudor's suitcase, for instance, or the classic spherical metal barbeque which Ron Kuivila brought (its hemispherical base and lid amplified separately), or the umbrella hung upside down by Edelstein, or the aluminum ladder which I appropriated from the theatre's technical crew and which had to be hung last, after it had been used to assist in hanging the other items. Ralph Jones transduced a clear plastic fishbowl inside which he suspended an air microphone, rather than using a more typical contact mic.

Of the more elaborate "compound" objects, those combining two or more acoustically linked items, some were "classics" from past *Rainforests*: D'Arcy Gray operated a reconstruction of Tudor's four Slinkys attached to a central transducer, Driscoll created a new variation on his toilet-float sculpture, and Edelstein made a new styrofoam-slab speaker using three large pieces of styrofoam separated by threaded metal rods. Unusual new compound objects were also brought forward by D'Arcy Philip Gray and John D.S. Adams. Gray operated a set of "headphones"—two large

tin cans which hung from a central transduced fixture, inviting the listener to place his or her head between them; each can received the transducer's vibrations differently, producing a complex "stereo" image. Adams brought a heavy stainless-steel item comprising four elongated hemispheres facing outwards (assembled with assistance from Toronto sculptor Reinhard Reitzenstein), which functioned in a manner somewhat opposite to Gray's tin cans, with each outward-facing unit offering a slightly different version of a single input transducer's signal.

The camaraderie amongst younger and older CIE members evident during the setup and performances extended to some of the "rituals" described in earlier chapters, particularly the presence of alcohol shared amongst the musicians—tequila, grappa—but in modest quantities, fulfilling a "kind of ceremonial" function (DeMarinis 2001). The quiet consumption of alcohol as part of the social fabric of the piece, shared by musicians visiting at each others' tables during the ongoing performance, was clearly done in part as a remembrance of David Tudor; stories of his ever-present "medicine man" concoction, and his interest in exotic alcohols, were easy to elicit. A reception for *Rainforest 4* performers and guests was held at the Upper East Side apartment of Carl McIntosh, an old friend of Ralph Jones, announced by email with the note that "In addition to hors d'oeuvres and Champagne, traditional *Rainforest* potables will be served in David's honor" (Jones 1998).

Performances were relaxed occasions. For the first three days we performed continuously for four hours each day, between 4:00 and 8:00 pm, and on the final two days we had eight-hour slots from noon to 8:00 pm, but these sessions were not demanding in the way that a typical focused concert performance might be. The way the musicians worked together was analogous to a number of chefs in a commercial kitchen, each responsible for a different aspect of a meal. This brought to mind the series of aphorisms, "Electronics and Cooking (In Memoriam David Tudor)", written by John Driscoll (1997), which dwelled on the parallels

between Tudor's musical practice and his love of food, and food preparation:

After cooking for many years one becomes a connoisseur of ingredients. The pursuit of ingredients begins to define culture. Some ingredients can be locally substituted for, others there is no substitute for. Slowly the hunt for ingredients becomes the pleasure, even more than the use of the ingredients.

[...]

A recipe, like a schematic, is not how to make something, it is the idea of something.

[...]

Once you have mastered a dish there is the desire to change it.

[...]

One spice combined with another can create a flavour which is not related to the original flavours of either spice.

(Driscoll 1997)

In this *Rainforest 4*, each performer contributed sounds judiciously to the total mix, akin to mixing spices to create a combined flavour which might evolve slowly from sweet to sour to salty; sometimes the overall sound was light and transparent, but then it could slowly build to a much more dynamic, even aggressive density: a situation which Tudor might have frowned upon, remembering his warning not to get "carried away" and forget the "tonal balance." (Tudor 1984).

My own process of approaching a first "professional" performance of *Rainforest 4* was, having arrived with a large palette of sonic possibilities, periodically to work at my table, creating a personal sound design which seemed to complement the current "flavour": occasionally I felt it was appropriate to introduce a sound element which would cut across the texture which had evolved, and I recall that on one occasion I received criticism that made me feel I had overstepped some unmarked boundary. The criticism took the form of little more than a raised eyebrow from Linda

Fisher; I sensed that it was perhaps because my sound (what it was is now forgotten) was too much an individualist statement, while I should rather be contributing to a seamless whole, "paying attention to the tonal balance". I felt that from time to time the introduction of a very strong, new element was warranted, but this was the exception rather than the rule; typically a new sound element would not appear abruptly and call attention to itself, but rather would fade in underneath the larger texture, and perhaps be revealed if and when the other texture dissipated. The metaphor of foliage is perhaps also appropriate here; although there is a general disavowal of any programmatic, naturalistic content in *Rainforest 4*, moving through the installation is a bit like moving through thick undergrowth, parting the fronds before you: new plants and animals become visible and audible. Although I had four objects to play with, I also discovered that it was wise to let them rest from time to time, or to program them with sound material which was quite intermittent, helping to thin out the overall texture of the installation.

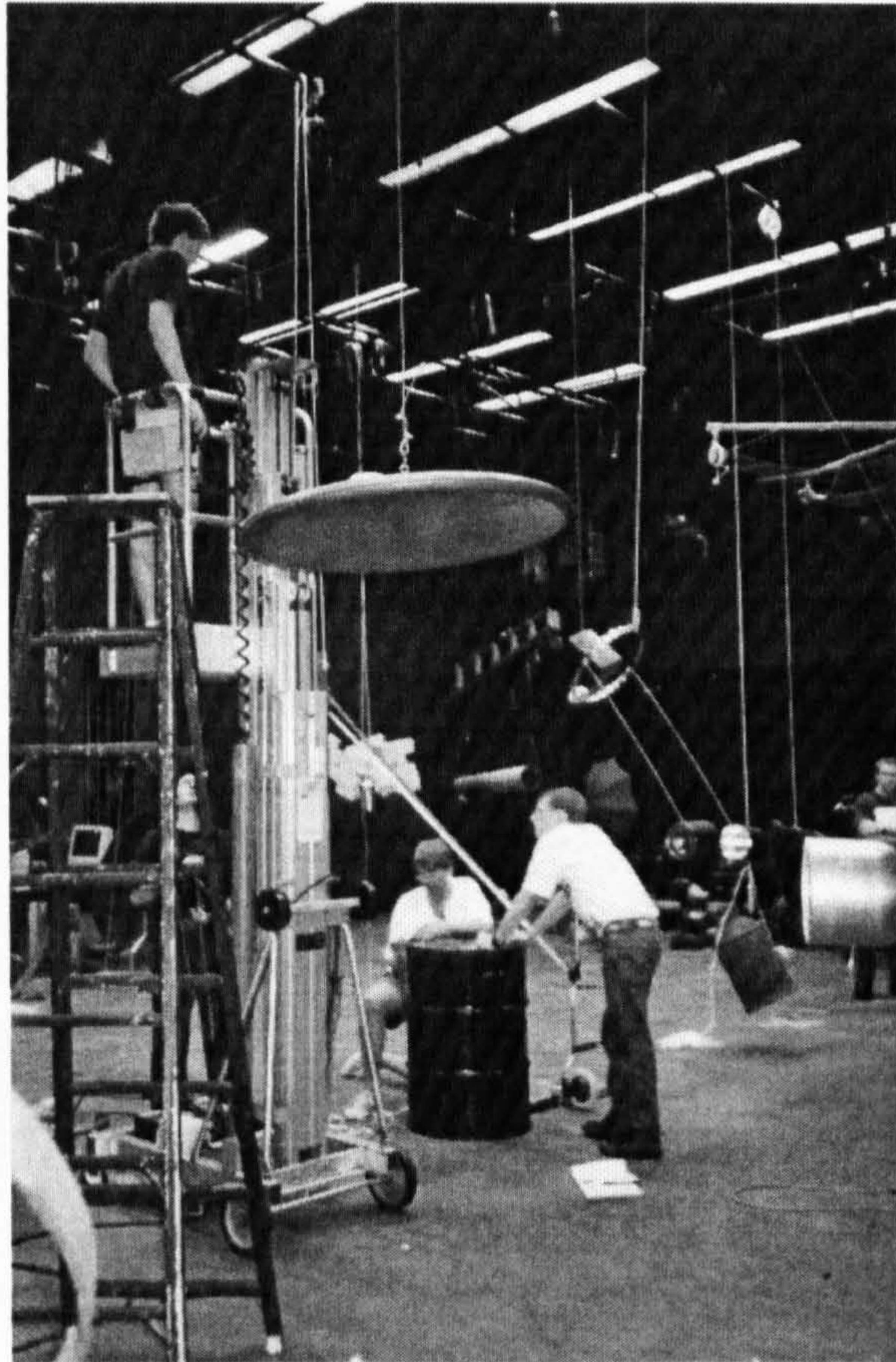
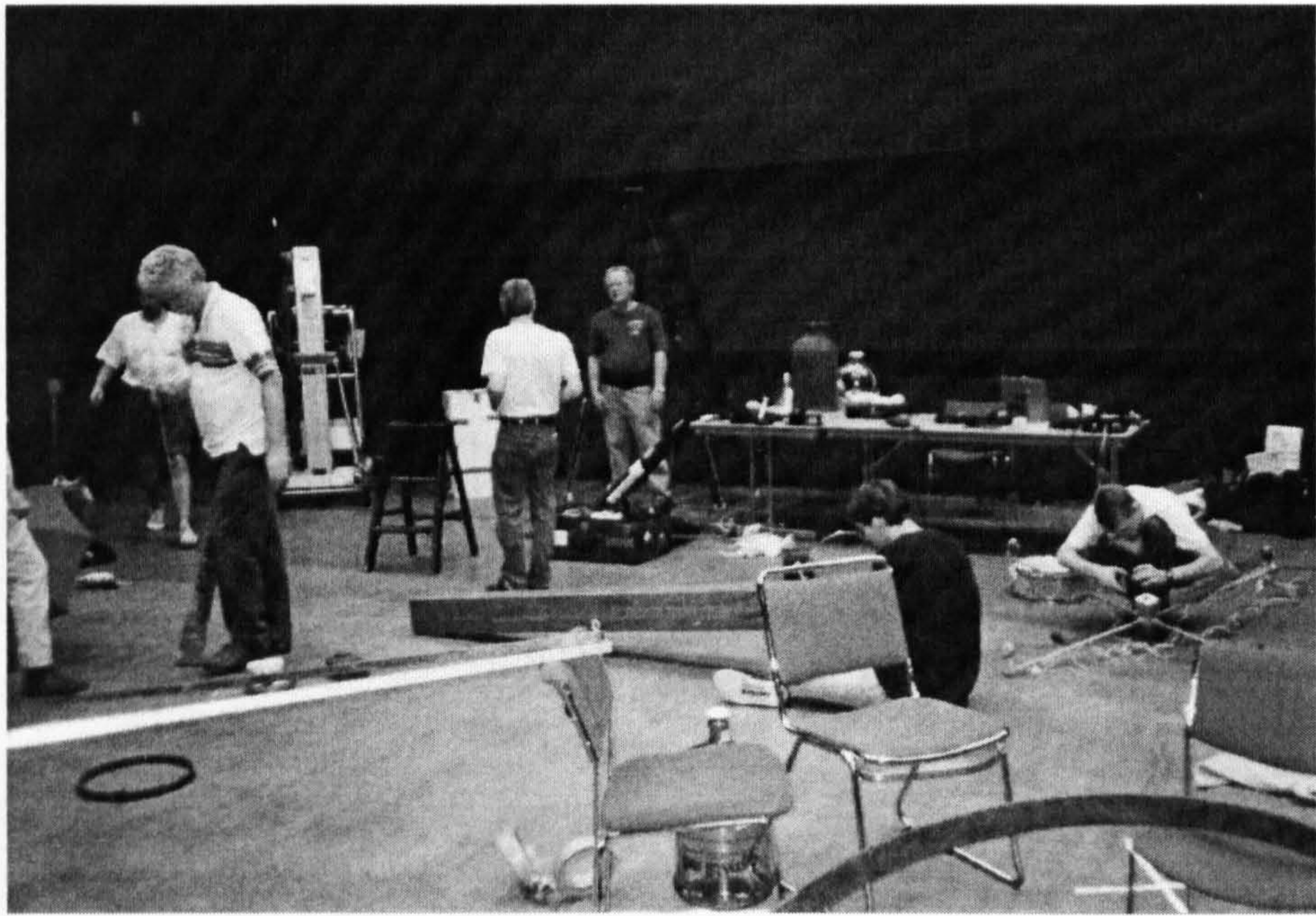

Figure 7-4. Views of installation process for *Rainforest 4* at the Clark Studio Theatre, Lincoln Center, New York City, July 1998. Top: from left to right, John Driscoll, Ben Manley, Ralph Jones, John D.S. Adams and D'Arcy Philip Gray. Bottom: John D.S. Adams, Phil Edelstein, Ben Manley, unknown. Photographs by Matt Rogalsky.



Figure 7-5. Views of installation of *Rainforest 4* at the Clark Studio Theatre, Lincoln Center, New York City, July 1998. Top: Paul DeMarinis, foreground, with the substantially completed installation. Bottom: Phil Edelstein, with collection of analog circuits from 1980s compositions in foreground. Photographs by Matt Rogalsky.



Figure 7-6. Views of installation of *Rainforest 4* at the Clark Studio Theatre, Lincoln Center, New York City, July 1998. Top: Ron Kuivila with graphics tablet and MIDI controllers, operating original software emulating Pepsi Pavilion processors. Vintage ARP 2600 synthesizer also on hand. In the background, artist Morgan O'Hara, documenting the installation of the piece, and Phil Edelstein. Bottom: John D.S. Adams and Linda Fisher with Lincoln Center crew member. Photographs by Matt Rogalsky.

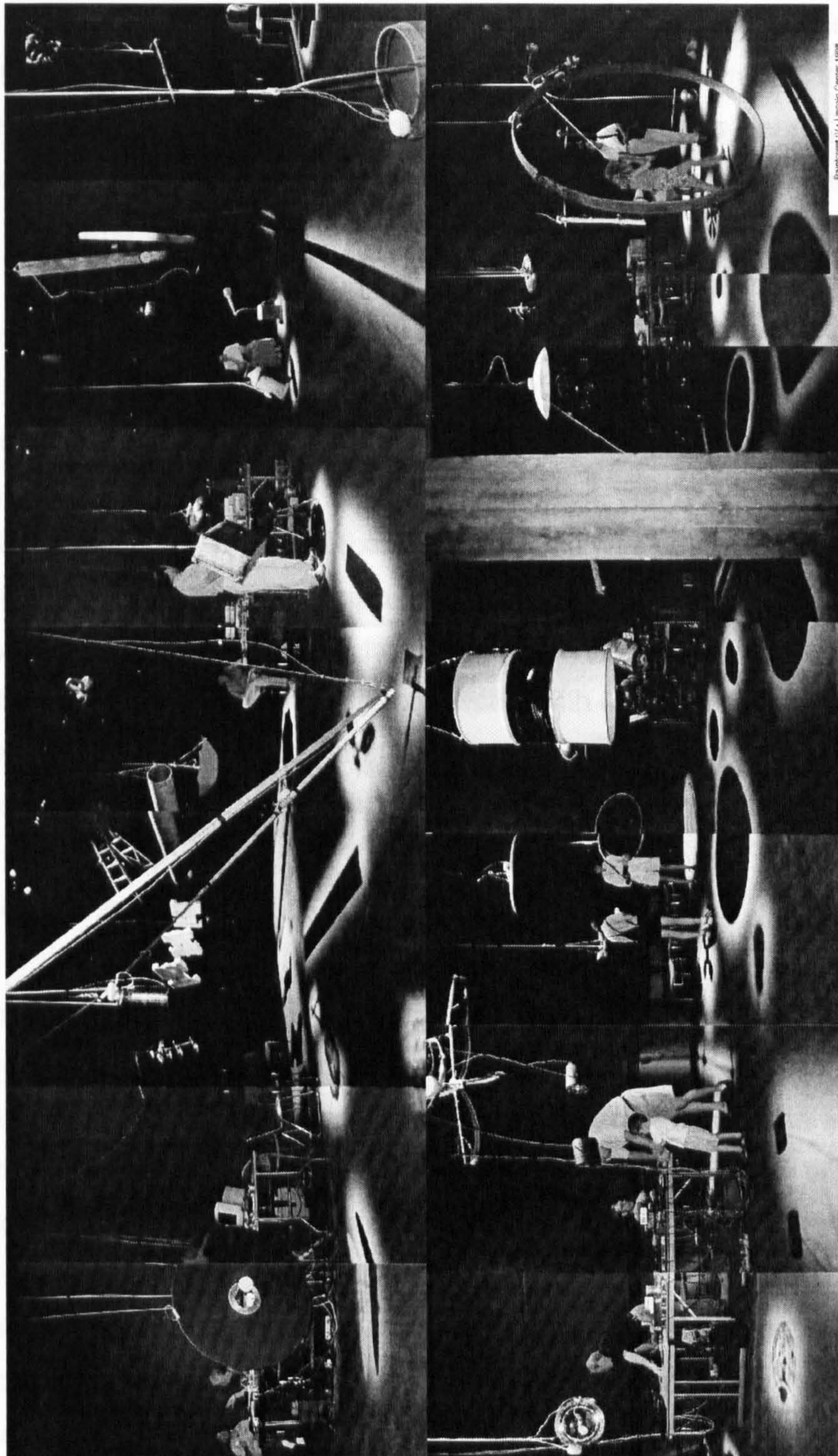

Figure 7-7. Panoramic view of installation of *Rainforest 4* at the Clark Studio Theatre, Lincoln Center, New York City, July 1998. Performers' tables from left to right: John Driscoll/Matt Rogalsky, Phil Edelstein/Ron Kuivila, Ralph Jones/D'Arcy Philip Gray, Linda Fisher/John D.S. Adams, Paul DeMarinis/Ben Manley (performers are not necessarily shown at their tables). Panoramic collage from photographs by Matt Rogalsky.

As a relative newcomer to the piece, I took many cues from observing how the other performers, particularly John Driscoll, whose table I shared, treated *Rainforest 4*. The social dimension of the piece was clearly important, and this included significant interaction with the public, people of all ages who could appreciate the piece on different levels. Children were encouraged to be adventurous in their listening, extending to holding some part of them in their teeth, to hear via direct bone conduction. A stethoscope-type device was also available which allowed the listener to touch a probe to a point on a loudspeaker-object to hear the resonances of the object; if a child, or an adult, seemed to be in a position to benefit from use of the stethoscope, it was offered, with detailed explanations of how the piece worked. I did not anticipate how many questions I would receive from adult visitors about the piece, and how the sounds and objects were connected with the performers; I found myself giving frequent demonstrations for curious listeners, manipulating my source material in such a way as to make the connection between it and myself obvious, by way of illustrating the range of control I had, and the possible responses of my objects.

I also found it enjoyable to watch, from a distance, one or two listeners engage in listening to one of my objects, and then to make a performance for that situation; the listeners would often then react with surprise as the object became animated and held their attention for a while, until either they or I became interested in something else. I was surprised later to read a description of exactly this "private performance" scenario in the writings of Phil Edelstein: "Often, as a player, you specifically prepare sonic delectables for specific audience members that come visit your instruments. Usually, interaction with the other players can be subjugated to looking to delight individual members of the audience" (Edelstein 2001).

The partial focus of the Lincoln Center installation, stated as "creating a new *Rainforest V* version for permanent installation", was an informal topic of discussion within CIE during the days of performance, but no

resolutions were arrived at. More concrete results were seen at the other focal point of the project, that of training younger performers in the practice of the piece and encouragement of its continuation. Following the installation, John Driscoll wrote an email to all participants thanking the younger performers in particular:

[...] I am still digging out from under all the Rainforest details, but I wanted to thank everyone for helping make a wonderful Rainforest. It was particularly heartening to be able to accomplish some of the goals initially set out including:

1) Create an elegant visual environment with the use of theatrical lighting. (Thanks to Beverly Emmons' magic and the LC Institute staff)

2) Train new members of CIE to be able to take the work out again. I hope everybody survived the experience -- particularly the long hours. It felt like everyone picked up the essence of the work and contributed in a wonderfully collaborative manner. I was delighted that we were able to do a largely acoustic version [primarily direct sound from the loudspeaker-objects, rather than "reflected" sounds heard through the conventional sound system]. This is due in part to the space, but also the sensitivity of everyone to the collective sound space.

[...]

Most important of all. It was wonderful to spend time with all of you, and to hear the richness of the piece once again. It was also vital to me that we were able to share the work with those of you who had not previously done it. In many ways this was the most fitting memorial to David that I could imagine -- to bring the piece roaring back to life and into focus again. It makes me realize how many emotions and memories I have wrapped up in this work. Thanks again for your patience, wonderful performances, good company, and dedication to making Rainforest alive again. I am very grateful to all of you.

(Driscoll 1998)

D'Arcy Gray and John Adams also both wrote to the entire group of performers, with similar sentiments:

Just a quick note to say thanks for everything. It was a wonderful experience. Thanks especially to the veteran CIE folks who put up with all my questions (especially you Ralph!). I think the

arrangement that we had [younger performers paired with older] was successful in teaching the piece to us rookies. (Gray 1998a)

A sincere 'Thank You' to you all for a beautifully heartwarming, gratifying and enriching experience with Rainforest. The spirit of community in the Clark Studio Theatre for those 7 days felt so right to me—quite a wonderful feeling. [...] I look forward to sharing the Rainforest 'stage' with you all soon. (Adams 1998b)

And of the original *Rainforesters*, all of whom expressed their satisfaction with the quality of the Lincoln Center production, Linda Fisher put it in the strongest terms:

Hey gang.

Just a quick note to say again how particularly wonderful and moving it was to do *Rainforest* with you all this past week. The experience comes close to being my "pilgrimage to Mecca". Thank you for your beautiful energies, goofy and profound sounds, and companionship in the RF ramble. Hope to hear from you and see you all soon.

Warm regards, Luf

(Fisher 1998)

Rainforest workshops with school children

Following the Lincoln Center performances, there were some immediate aftereffects which seemed to indicate some success for the "training" aspect of the project. In November 1998, D'Arcy Gray and John D.S. Adams were engaged by the Lincoln Center Institute to hold *Rainforest* workshops for New York City school children. As a pedagogical device, *Rainforest* can be used creatively to teach aspects of acoustics, composition, improvisation, amplification and microphone usage, not to mention sound sculpture, and skills useful for developing source materials: field recording, synthesis, and circuit design. The intended effect of the workshops was to create, through an understanding of *Rainforest*, a deeper awareness of the behaviour of sound.

As part of the workshops, Gray and Adams made a short *Rainforest* performance for each group of children coming through (Gray later wrote to members of CIE: "John and I were forced to break tradition and NOT drink grappa during the performances—at 9 am coffee seemed to be more appropriate. Sorry!" (Gray 1998b)). These performances were significant in that, for the first time, an attempt was made to create a collection of original source sound materials from Composers Inside Electronics members, closely matched with specific loudspeaker-objects. Adams sent out an email to the Lincoln Center performers requesting submission of soundfiles per object:

As you all know D'Arcy and I will be performing 16 objects for the Lincoln Center Institute school concerts in November (5th - 20th). To do this we will be running 8 CD players, each channel running discretely into each of the objects via the appropriate amplification, etc. If you could provide us with the source material including any processing, we will compile the material and burn the CDs ourselves. Since we will be trying to minimize the table-top setup (8 objects each will keep us fairly occupied!) please make sure that the material you provide is fully processed. [...] Here is a list of the objects that we'll be using and who's responsible for the source:

- 1) Hard Disk - Matt R
- 2) Water Bottle - John D
- 3) Squeaker - John D
- 4) Floats - John D
- 5) Medium wagon wheel - Linda F
- 6) Copper Still - Linda F
- 7) 55 Gallon Drum - Linda F
- 8) Plastic Globe - Ralph J
- 9) Treasure Pot - John A
- 10) Large Organ Pipe - John A
- 11) Sono Tube - Ron K
- 12) BBQ - Ron K
- 13) Metal Shield - D'Arcy G
- 14) Large Bamboo - Paul D
- 15) Copper Strip - Phil E
- 16) Styrofoam - Phil E

(Adams 1998a)

The library of sound materials which Adams and Gray collected, in combination with this very specific reduced set of *Rainforest 4* objects (most of which are "classics" dating back to the 1970s), suggests an approach to programming a "living archive" version of the piece (similar to the Thundergulch proposal), and feeds into discussion of future possibilities. In 2005, Gray recalled the workshop series in the context of a renewed discussion around "*Rainforest 5*":

[...] those LCI [Lincoln Center Institute] workshops were much closer to the idea of the permanent *Rainforest* than you might think. John A and I were using legacy objects, chosen by the group (not by us alone) and using source material selected by the group. Our role at the time was moving more in the direction of the "explainer" [...]. I think this is experience we can build on for a permanent installation. It did lack some of the energy of a full-blown RF IV, but under the circumstances was quite successful artistically. (Gray 2005)

Gray and Adams presented this version of *Rainforest 4* to more than 3000 school children between November 5 and 20 1998 (Gray 1998b). Although the presentations were not lengthy (and were not "hands-on" in the sense that the children did not develop their own original objects), by all reports the students found *Rainforest* exciting and ear-opening: John Driscoll recalled seeing them tapping surfaces of walls, doors and other objects as they left the workshops—"tuned in" to the inner sonic worlds of these everyday items.

Following their school group workshop series in New York City, Adams and Gray continued to work energetically together on *Rainforest 4*, first organizing a workshop performance of the piece with students at Mills College, Oakland California, on March 15 1999, and then a larger installation at The Music Gallery in Toronto Canada on April 23 and 24 1999. The Mills College production was part of a week of events honouring David Tudor, and unfortunately, by Gordon Mumma's account, it suffered from some of the possible dangers of *Rainforest 4* as free-for-all:

[...] a large scale performance [...] in which no one listened to each other, and most participants made excessively loud and muddy noise to drown out everyone else. That juvenile-macho occasion was not David [Tudor]'s concept of RAINFOREST! (Mumma 2001f)

D'Arcy Gray concurred, later writing:

I had thought that RF IV was mostly self-explanatory, but I was largely disappointed with the results. And this was a situation where there was some coaching of the participants—and at Mills where there should be some degree of sensitivity already. (Gray 2005)

Gray refers here to Mills' historical and present-day role as an important site of experimental music practice.

Reports of problems with this performance suggest strongly that *Rainforest 4*, while it might "teach itself" (in Tudor's words) to those who, in a sense, already have an understanding of what is expected of them, is a piece which requires careful oral transmission to those who are unfamiliar with, or resistant to, the unwritten "rules" of the piece. As I know from my own experience in the 2001 CalArts performance (described later in this chapter), there is a fine line between directing musicians in "appropriate" directions, and stifling creative energies which might in fact be entirely in keeping with the ethos of the piece, while being quite contrary to one's own view of *Rainforest's* aesthetics.

The Toronto installation of *Rainforest 4* which followed was not a student project, however, and was smaller in scale, with a very reduced group of performers: Gray and Adams were to be joined by Linda Fisher in a trio performance. Ultimately, Fisher withdrew from the project due to illness, tempered also by the feeling of being "overwhelmed, not having the equipment, the instruments. Having to come back into it and put it together". Fisher has stated that the Lincoln Center performance marked

her "retirement" from the piece, which she comments is "so ridiculous—how do you retire from *Rainforest*, really?" (Fisher 2003). Her decision not to involve herself with future performances was not absolute, however:

I fully expect that someday I'll do it again before I die. I don't know why, but weirder things have happened. And I don't know, I mean, it was certainly a highlight of my life to do this piece and it continues, even now, to reveal things about itself and David. And one thing I always think about David is that he was such a quiet person, in a way, didn't announce himself or advertise himself or his ideas or his theories. And, like any good teacher, was willing to plant a seed and not have to see the immediate result. You know, kind of knowing here's some fertile ground and throwing these seeds there and see what happens. And even this many years later, I have insights from that time. Which is a sign, I think, of a really deep work, a deep relationship—you know, that it can continue to reveal things. And it's tempting; you know everywhere I go, I see objects.

Due to Linda Fisher's withdrawal from the 1999 Toronto installation, I received an invitation from John D.S. Adams and D'Arcy Gray to join the project as third performer, which I enthusiastically accepted. As a result, this performance was not only the first *Rainforest 4* presented in Toronto since Tudor and Driscoll had brought the piece to York University in 1975, but was the first Composers Inside Electronics event made up entirely of younger members who had been brought into the group since its revitalisation in 1996. My recollections of the two-day performance are that it felt comfortable: the variety of objects included many which were brought to Toronto from the Lincoln Center performances, and I used a soundmaking setup which duplicated what I had used there. In such a small performing group, musical decisions and "directing" the flow of the piece seemed much more easily accomplished than in the large group at Lincoln Center. The "traditional" presence of potent alcoholic beverages was observed; I recall that I bought a bottle of grappa on my way through the duty-free shops at Heathrow with David Tudor, Adams and Gray in mind, and it was consumed, with the help of some visiting friends, during our setup and performances.

Between 2000 and 2006, with the exception of fairly regular student presentations of *Rainforest 4* at Wesleyan University, where Ron Kuivila has used the piece as an undergraduate composition and performance exercise, the piece has had only two public presentations. The more recent was a one-day performance on May 25, 2003, in the Spiral Hall of the NTT Intercommunication Centre in Tokyo, Japan, by Takehisa Kosugi, Yamataka Eye, and Kiyoshi Izumi, presented in connection with the exhibition, "The Story of Experiments in Art and Technology". If *Rainforest 4* is a piece which depends to some extent on an "oral tradition", and Composers Inside Electronics "membership" is dependent on performance with those who worked with David Tudor, or those who worked with people who worked with David Tudor—involving transmission of some knowledge or awareness of his practice—then it is interesting to consider an expanding international "diaspora" of *Rainforest* performers as an integral part of keeping the piece alive. Whether Composers Inside Electronics has some sort of monopoly on production of the piece and maintaining its "authenticity" is dubious, however.

How to maintain the piece, and extend it, resurfaced as topics of debate within CIE during the 2001 production of *Rainforest 4* at the California Institute of the Arts, as part of the symposium, "The Art of David Tudor: Indeterminacy and Performance in Postwar Culture", organised by the Getty Research Institute in Los Angeles between May 17 and 19. Numerous papers were presented during the symposium, including a thumbnail history of *Rainforest* co-authored by myself and John Driscoll, a version of which was eventually published (Driscoll and Rogalsky 2004). Neither our paper nor any of the others considered future directions for *Rainforest*, however, and this topic was left to informal discussions, such as those during dinner talk with John Driscoll, Ralph Jones, John D.S. Adams and myself, documented in my notes. They are reproduced here as a means of conveying the casual, roundtable quality of the meeting:

Very interesting conversation led by JD about his frustration with continually being the point person for CIE, very time-consuming and generally unrewarded, always smoothing the way for everybody else to just swoop in and do their artistic thing. He declared he felt it was time for the older CIE members to do their own turn at "giving the piece away", to step out of the equation and let a younger generation of CIE members take responsibility for determining RF's future. RJ bridled at this somewhat—he intends to muster a big and beautiful RF in San Francisco in a couple of years which will "set the standard, because it definitely does need to be set". [...] JD says he has been willing to take on the role of point person out of dedication to DT. He mentioned Lincoln Center as a very deliberate strategic "turning point" for RF—bringing in a crop of younger musicians and beginning a process that will eventually lead to the retirement of the older generation from performing the piece. He said a few interesting things about the piece—that it was not important to maintain "historical" RF objects as part of the piece (even proposing to just get rid of them and start afresh)—that he imagined the piece would (and should) change its identity with a younger group performing it which will have to invent its own traditions and rituals. He said that JDSA, D'Arcy and myself were trusted implicitly by him to further the piece because we three had come forward to help DT at a time when the older CIE members could not. [...] RJ followed on [responded to] JD's expression of frustration—and firm pronouncement that he will not be fulfilling the role of enabler any longer—with statements of his (and other CIE members') deep appreciation of his [Driscoll's] commitment and work over the years. He says a San Francisco RF will be 100% organised by himself. JDSA pointed out that he successfully organised the RF in Toronto in 1999 and that he, D'Arcy and myself successfully mounted it, making necessary aesthetic and technical decisions. (Rogalsky 2001)

Composers Inside Electronics personnel for the 2001 CalArts installation included Driscoll, Jones, Adams, Gray, Paul DeMarinis, Ron Kuivila, Bill Viola and myself, in addition to CalArts lecturer Mark Trayle and about a half-dozen of his electronic music students; the venue was, as at Lincoln Center, a large, black-box theatre, with similarly impressive lighting of a vast array of loudspeaker-objects. If the 1998 *Rainforest 4* at Lincoln Center had seen the first presence of computers as sound sources, this *Rainforest* was dominated by them, particularly the uniform shapes of recent-model Apple Powerbook laptops, which most of the students seemed to be operating as their main instruments. I myself was using one

of these, and found myself inwardly fighting against the visual uniformity of things:

There is a flux of Powerbooks in the theatre—at least 8 or 10 including a couple of students with latest models. It's a bit nauseating but you have to remember that despite the apparent homogeneity of instruments, the programming is at the heart of the sounds and each machine is a virtual tabletop of devices. Unfortunately I hear a lot of students employing the jagged sounds of digital distortion, which I haven't learned to love. (Rogalsky 2001)

The presence of these "unpleasant" sounds was interesting to me, because I had to stop and puzzle over my reasons for rejecting them. The type of digital distortion to which I referred in my notes is characterized by disintegration of a signal into fuzzed-out, clipping noise, and is easily generated with overloaded Max and SuperCollider DSP patches. Most students were using either one or the other programming language, and were producing a great deal of what I considered to be "characterless" noise which had the effect of masking other *Rainforest* sounds. I found this ear-fatiguing and encouraging of the type of ever-louder sonic one-upmanship such as that which Gordon Mumma characterized as "juvenile-macho" (Mumma 2001f).

None of the students seemed to be concerned about this; it was an interesting opportunity to reflect on my own biases against certain qualities of sound, and what was "appropriate" for the piece. I wondered if it was simply a generational issue; after all, the students performing with us were perhaps fifteen years younger than myself, listening with different ears. These students had grown up with digital media all around them and seemed as comfortable with digital distortion as I would have been with a "warmer", more "characterful" analog distortion. One of my sources at CalArts was again the digital feedback instrument that I had designed around a multi-effects module (Rogalsky 2002). This had the capability—or tendency—to produce harsh, hissy digital clipping noise of the same sort that I was hearing from the various students' Max and SuperCollider patches. I steered away from those zones in favour of

sounds which approximated the type of semi-repetitive, semi-patterned utterances which I felt were more in keeping with the "electronic ecology" of David Tudor's *Rainforest*, where the goal seemed to me transparency of sound, rather than washes of noise which obscured other, more delicate noises. I did not choose to comment on the sounds I found less interesting; I continued to use them as an opportunity to question my own choices.

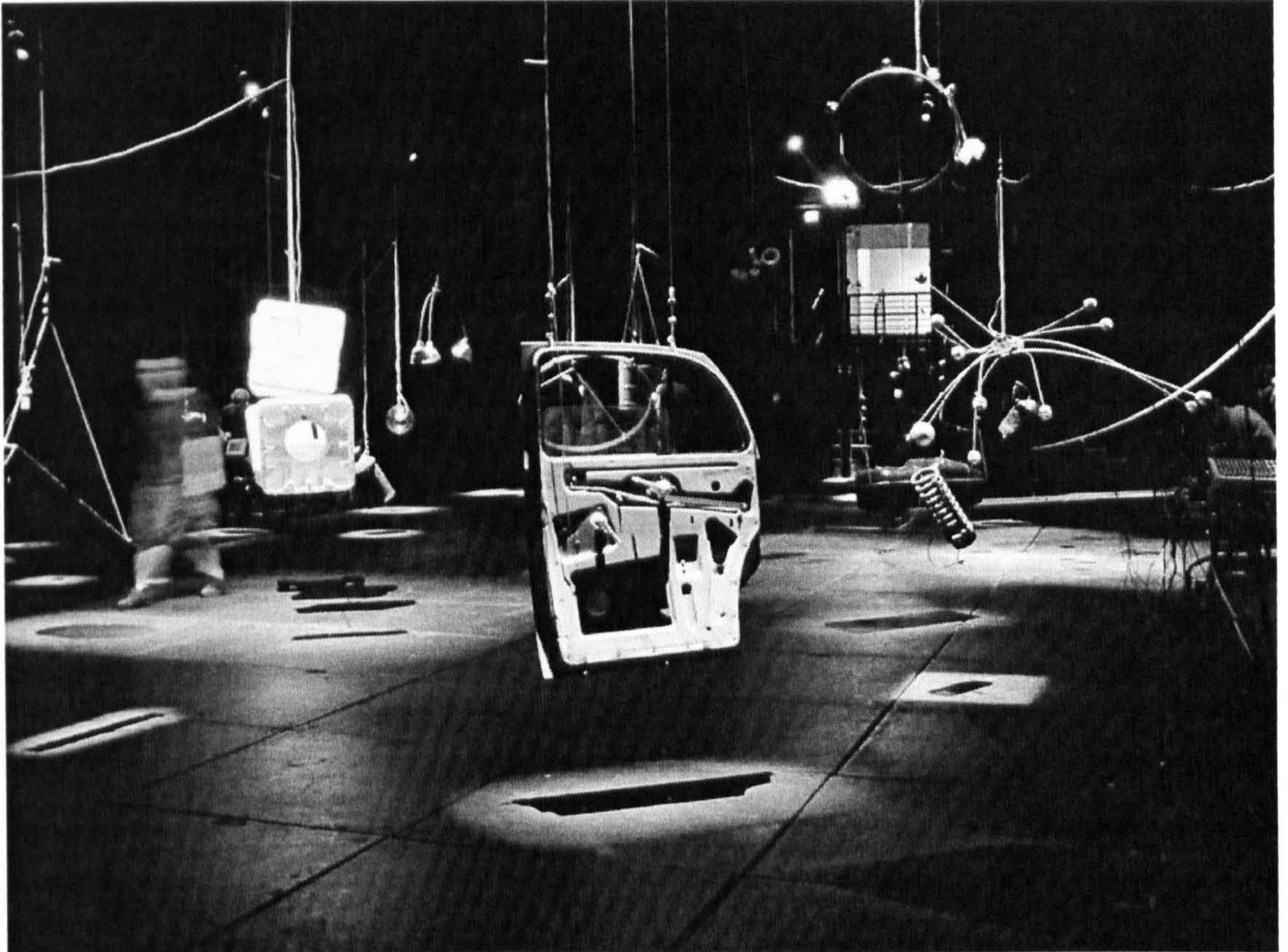

Figure 7-8. View of installation of *Rainforest 4* at California Institute of the Arts, May 17 2001. Photographer unknown.

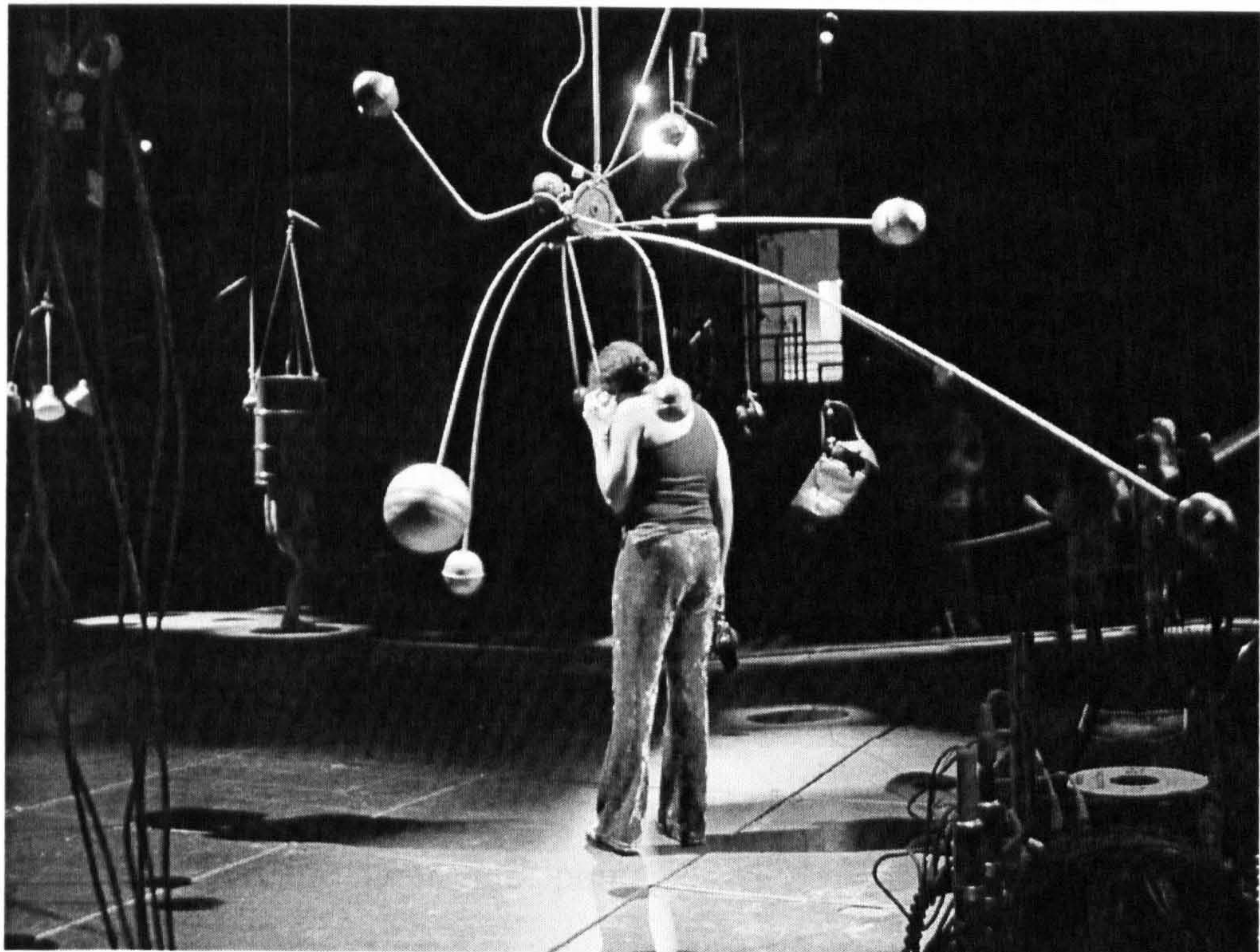

Figure 7-9. Views of installation of *Rainforest 4* at California Institute of the Arts, May 17 2001. Photographer and subjects unknown.



Figure 7-10. View of installation of *Rainforest 4* at California Institute of the Arts, May 17 2001. Photographer and subject unknown.

Discussions re: *Rainforest 5*

The CIE gatherings for both the 1998 Lincoln Center and 2001 CalArts performances of *Rainforest 4* were seen by its members as opportunities to have a focused group discussion about the current state of the piece, its future, and possibilities for extension of the work into a *Rainforest 5* (with the general understanding that it would likely comprise a permanent installation of some sort).

Several months before the Lincoln Center event in July 1998, John Driscoll wrote to the other participants,

I have viewed this from the beginning as an opportunity to introduce new people to the work and to perpetuate the piece. In this light, I would like to have those of us who have done *Rainforest* before work together with those who have not (ie. John, D'Arcy, Ron, and Matt - who did *Rainforest II* with me recently at Wesleyan & Köln).

This will allow us Wed eve, Thurs, and Friday together before we take shifts on the weekend.

[...]

I will be working on setting up some kind of reception for folks who are interested in the idea of a permanent *Rainforest* (possibly the Wed eve. performance). So we are trying to take this 25th anniversary opportunity to help perpetuate the work as well as present it once again.

Unfortunately, as Driscoll stated later, "I had hoped to be able to set up a reception for *Rainforest 5* interest, but did not have the time or contacts to pull it off" (Driscoll 2006b). Driscoll was the primary organizer for Lincoln Center and also financially supported it through his media production company Shadow Interactive, Inc. "It always seems that the obligations of mounting the installations take over from whatever other plans I have in mind", he later wrote, reflecting the need for organisational matters to be better divided among multiple people. During the run of *Rainforest 4* at Lincoln Center, Driscoll did manage to speak individually to some potential supporters of future *Rainforests*, however:

I was pleased to see that both Christof DeMenil [art collector and philanthropist] (who has taken prior interest in the work) and Nancy Perloff [curator] from the Getty [Research Institute] were able to see and hear the work. Both of these people may be able to play a role in the longer term opportunities for a permanent *Rainforest*, as well as Nancy was interested in having *Rainforest* as part of a symposium on David at the Getty. We also received interest from the Hebbel Theatre in Berlin, the Peabody [Museum] in Baltimore, Phil has a contact for Japan, as well as an interest from Herb Levy at Periplum Recordings for putting out a CD of *Rainforest*. (Driscoll 1998)

Indeed, Nancy Perloff was instrumental in bringing together the next large-scale *Rainforest 4* in 2001 at CalArts, as part of the Getty's Tudor symposium; other leads Driscoll mentioned have not yet resulted in any specific actions.

Although CIE did not have a formal meeting or reception for potential funders during the *Rainforest* run at Lincoln Center, in September 1998 John Driscoll and Phil Edelstein met in New York City with Jean Rigg,

David Tudor's long-time friend, specifically to discuss ways and means of continuing his work. Rigg, formerly manager of the Merce Cunningham Dance Company and now a New York-based attorney, had been central to resolving legal matters related to Tudor's archive, overseeing the deposit of his papers with the Getty Research Institute and his electronic devices with Wesleyan University, and acting as liaison with the Tudor Estate. According to Driscoll, the outcome of the meeting was a decision "to concentrate on two areas (documentation and finding a permanent home for the work). This will, given limited resources, hopefully ensure the piece will carry on" (Driscoll 1998a). Given the scarcity of time, however, it seems that these goals remained generally acknowledged as useful, while practical steps towards achieving them were not able to be taken.

During the 2001 installation of *Rainforest 4* at CalArts, another attempt was made to call a formal CIE meeting. John D.S. Adams wished to arrange time for one during the group's busy week, which saw CIE shuttling back and forth between the theatre where *Rainforest 4* was presented, and the Getty Museum in Los Angeles, which hosted the Tudor symposium, some hour's drive away. Adams wrote to the CIE performers:

I just wanted to get everyone the most up to date *Rainforest* schedule for this coming week. You'll notice on Friday I've slotted in a meeting (after the performance and before the evening concert?). I'm sure we all recognize the importance of discussing and then establishing the ground works for a protocol for future RF presentations. The schedule of events is dense, but I really hope we can get everyone together—these occasions are rare!

[...]

Friday May 18

PERFORMANCE 2pm - 5pm

Proposed meeting to discuss the future of RF (Time and place TBA)

Once again, due to a chaotic procession of events, there was no formal meeting; there were, however, many opportunities for informal discussions, and several after-dinner sessions with most of the CIE

performers present were a fascinating combination of reminiscences from those who had worked with David Tudor, together with some casual voicing of opinion on where *Rainforest* might go next. Beyond Ralph Jones' plans to organise a San Francisco installation, nothing more concrete was arrived at.

After returning to his home in Toronto, John Adams wrote a lengthy email to the group outlining his thoughts on San Francisco possibilities and other matters relating to the continuation of Composers Inside Electronics:

Hi Everyone,

It's been a couple of weeks since our LA Tudor hang and I just wanted to break the ice and get the dialog going again on *Rainforest* and its future incarnations.

As it stands the next major installation is planned for San Francisco sometime in 2003. Ralph and I spoke about how we might go about getting the ball rolling and decided that we first needed to establish a body that would administrate the prep required. As we all know (John D more than anybody), this is a enormous task. Once this has been sorted out, our lines of communication can be established and we're off.

We'll need to approach this as realistically as possible, and I think a lot of it depends on how much time each of us has to offer. John D recommended, and I think we all realized from our experience with the CalArts/Getty presentation, that we will need one person to funnel all this information through, who will then distribute it to those who need to know. John D should be commended on his professional and transparent handling of the administrative duties gone by, but he has decided to hand over the baton to someone else. The future of *Rainforest* owes a lot to John D for the significant contributions he has made. Thanks John Driscoll!

There has also been discussion on what organization can act as a front for our presentations. It seems Art Services [sic] is not possible, and there have been a couple other names that have come up: Electronic Music Foundation, and Oliveros Foundation. Any others? Firstly, it should be clarified what would be expected from this type of affiliation. Secondly, what are the strengths and weaknesses of the organizations in question.

There are many more topics that we need to cover, but I just wanted to get the ball rolling. If you think there are other people who should be a part of this initial dialog then feel free to forward this email to them, just let us all know.

It was so great seeing and performing with everyone in LA. Amidst the academic weirdness was an incredible energy surrounding the symposium. I hope this email finds you all well. Looking forward to your thoughts.

Best Regards,
-John DS

(Adams 2001)

The projected *Rainforest 4* for 2003 in San Francisco did not materialise, unfortunately, due primarily to the fact that neither Jones nor Adams could devote the time necessary to bring the project to fruition: Jones explained: "It went off the radar because I have so many other responsibilities, I just don't have time to do a proper job of producing a *Rainforest*. I really wish it weren't so, but right now, that's my situation. Also, the stock market tanked and the company that I had targeted to fund the performances cut back on their arts giving" (Jones 2006b). Whether the project might have found success if more CIE members had been able to pool their resources and find support for it is open to debate, but the situation which Ralph Jones describes is much the same for all other members, who now have full-time commitments either as practising artists or professionals in other fields, or both.

Up to the time of this writing, the California Institute of the Arts production in 2001 remains the most recent large-scale installation of *Rainforest 4* to have been presented by Composers Inside Electronics. The 2003 performance of *Rainforest 4* in Japan mentioned earlier in this chapter was significant in that it represented another direction of growth for the piece, apart from the CIE structure but still connected directly with Tudor and CIE, via Takehisa Kosugi.

2001: Proposal for a virtual *Rainforest*

It would be appropriate to mention at this point a personal project which I undertook in 2001 as an outgrowth of my experiences with *Rainforest 4* (and recreations of Tudor's *Rainforest 1* and *Rainforest 3*), which I imagined as a direction worth exploring towards a *Rainforest 5*. This took the form of initial investigations into creating a completely virtual *Rainforest*, to be experienced through binaural audio. This was successfully accomplished, to the extent of producing a demo illustrating the feasibility of the idea, through the use of convolution techniques combining impulse responses, taken from real-world resonant objects, with a variety of source audio programs. The similarity of my project to John Driscoll's 1996 Thundergulch proposal, as it privileges the "remote listener", is quite striking, but at the time I was unaware of the details of that proposal.

The mathematical technique of convolution (a complex multiplication of two signals, in which frequencies common to each are reinforced) is now commonly used for making highly realistic recreations of reverberant spaces: an impulse response is made for a given room—by recording the room's response to a sharp impulse like a pistol shot—and it may then be convolved with other "dry" sounds to place those sounds in the virtual space, with a great degree of realism. During the CalArts performances, I began to imagine that if I could successfully record the response of a *Rainforest* object to an impulse, that I could then use that impulse response in combination with raw source sounds to hear those sounds as if they were being played through the object.

When I returned to the UK following the Getty's Tudor symposium, I devised a method for recording object impulse responses, in order to test this idea. Using the SuperCollider programming language, I wrote a patch which generated white noise bursts which were played through an object via a usual *Rainforest*-type transducer. At the same time, my

SuperCollider patch recorded the resonances of the object via a piezoelectric contact microphone attached to the object. At the abrupt end of a sustained burst of white noise, the object continued to reverberate for a short time, and it was this reverberation which I excerpted from the object recording to use as an impulse response. Of course these impulse responses were highly coloured by the acoustic qualities of the transducer and pickup, but I was primarily interested in testing the basic idea, with refinements to come later. I made impulse response recordings for four small test objects, three of which I had actually used in the CalArts performance: an aluminum soap dish, a tin can, a wooden Sacher torte box, and a slab of styrofoam (documented on the CD accompanying this thesis).

Using the shareware/freeware application SoundHack, I experimented convolving these impulse responses with a variety of "input" sounds. I was very pleased to find that there was indeed a tremendous realism in the resulting soundfiles, much as if I had played those sounds through the actual objects and recorded them via a contact microphone.

At this point I was dealing with monophonic recordings, imagining each virtual object as a point source. To place these virtual objects in a believable virtual space, I again employed SoundHack, which offers binaural processing using head-related transfer functions to place a monophonic source at any arbitrary angle around the head of a virtual listener. The result is a stereo soundfile which, when listened to with headphones, gives a remarkably good sense of space, including awareness of sounds as being "in front of" or "behind" the listener.

The binaural demonstration track which I produced places my four virtual *Rainforest* loudspeakers, each with distinctive program material so they may be easily differentiated, around the headphone listener as if each were in a corner of a room with the listener in the middle. The objects are introduced one at a time, and also fade out in that manner (this mix is also included on the accompanying CD).

Since the results of the experiment were promising, I made some effort to find collaborators to help realise an interactive version, which I imagined as a web-based, virtual *Rainforest*. Visitors would select objects (from a library of available impulse responses), pair them with a range of available sound sources (with the possible option of uploading new sound materials), and place them in a two-dimensional "room" in relation to a virtual listener. At that point, the visitor would click on a button which would perform all the necessary convolutions, and (after a delay) generate a unique binaural soundfile for the visitor. I made additional tests of streamlining this process using CSound rather than SoundHack, but was unsuccessful in finding a programmer-collaborator to help develop a web interface to CSound. I did have the opportunity of sharing the idea with many people, however, first through a public presentation at a Sonic Arts Network festival in Norwich, UK in July 2001, and, some time later, through distribution of my demonstration soundfile with documentation to various members of Composers Inside Electronics.

I did not imagine this web-based project to be *Rainforest 5*, but I thought it could be a means of providing a meaningful experience of *Rainforest* to a large, remote audience. Extensions to the idea included development of a more interactive version of the web-based *Rainforest*, avoiding the delays associated with non-realtime processing, and the notion that it could be possible to develop a visual presence for the online "installation", so that visitors could actually navigate around objects placed in the virtual space, with corresponding changes in the balance and binaural positioning of sounds "coming from" the objects.

Similarities between my imagined "virtual *Rainforest*" and the project set out in the 1996 Thundergulch proposal are limited to the binaural delivery of a "*Rainforest* experience" to remote listeners, since in my imagined project there was no requirement for a physical installation.

2005/2006: Renewed discussion of the future of *Rainforest*

Between 2002 and 2005, little activity was evident with regard to the goals set forward by John Driscoll and CIE during the events of 1998 and 2001. Then quite suddenly, in May of 2005, there was a sudden surge of interest in discussing the future of *Rainforest* via email. It seemed to begin with a note I sent to John Driscoll regarding our co-authored paper on the history of *Rainforest*, which had recently been published; Driscoll responded with some new information:

I met with Jean Rigg recently regarding a discussion about the trust that has been set up for David Tudor and is being administrated out of Artservices. She wanted to go over the idea of a permanent *Rainforest*. We discussed many things, but the long and short was that there is interest from the trust to find a way to make a permanent version. I suggested that one possibility was to propose a series of CIE installations to Mass Moca [Massachusetts Museum of Contemporary Art] and include a summer workshop for *Rainforest* that we would work on a permanent version. We could then invite interested parties to see it in action. Any thoughts? Are you still thinking about a summer workshop?

The aspects that we discussed were having it installed in some public facility that could be visited by a wide audience—including children. Also that it had an educational experience that demonstrated the concept, transducing, sound sources, etc. (most likely interactive and also a web component). We also spoke about the ability to access the space and objects over the web, and to have people perform over the web. Jean was a little reluctant, but after a while I think she realized the value of another way of accessing the piece, even though it may not be the same experience as being physically in the space. She missed the idea of actual performers, and I explained maybe something like the Explainer program at the Hall of Science [in Brooklyn NY] where college interns staff the floor and answer questions and interact with the public.

I am going to send the *Rainforest* part on to all the CIE folks as well. Maybe it would be worth setting up a blog for discussion back and forth.

(Driscoll 2005c)

This seemed in some respects to be a revisitation of Driscoll and Edelstein's consultations with Jean Rigg in 1998, with the new factor being the creation of a David Tudor Trust, set up as a project of Performing Artservices after discussions with Tudor's estate.

Driscoll did send out another email the same day, to John D.S. Adams, Nicolas Collins, Paul DeMarinis, Phil Edelstein, Linda Fisher, D'Arcy Philip Gray, Ron Kuivila, Bill Viola and myself, repeating the details of his meeting with Rigg quoted above. A flurry of emails followed, revitalising debate on immediate and long-term possibilities.

Phil Edelstein was the first to respond, revealing that he had recently (on April 15 2005) registered three CIE Internet domain names (composers-inside-electronics.com, .net, and .org), with the idea that a CIE website "could hold blog'ish [weblog] pages from individuals along with material that we would like to make available as a group" (Edelstein 2005e). Edelstein further suggested organising a meeting with representatives of Harvestworks in New York City and the Electronic Music Foundation, based in Albany NY, and again voiced his support for a permanent installation:

I like the idea of an internet enabled RF tagged as Rainforest V (John probably credited with that as a moniker). Seems to me we should think large and talk of both permanent installations (note plural) of Rainforest IV complemented synergized (though not homogenized) with RF V.
(Edelstein 2005e)

Edelstein contributed to the discussion a diagram of a possible organisation of a CIE webspace, shown in Figure 7-11. To date this has not been realized; the composers-inside-electronics website is currently hosted from a server in Edelstein's home, and its public aspect is little more than a placeholder page. A password-protected area, however, contains a large, semi-organized trove of CIE and David Tudor archival materials, from copies of correspondence to photographs of *Rainforest 4* installations, to full-length recordings of CIE performances.

Ron Kuivila, in response to John Driscoll's email, focused on the idea of a "virtual" experience of *Rainforest* which might not need to be connected to a physical installation:

It strikes me that a WWW interface has two different roles: maintenance and visitor access. The maintenance part makes sense to me, the visitor part less so. [...] the inevitable delays and overlaps [due to Internet routing] would make what can be an obscure experience utterly baffling [...]

The visitor access part might be done by analyzing the objects and implementing them as resonant filter banks [...] So, this would not have to involve playing the physical installation. This could probably be implemented as a jsyn patch that would run on the visitor's computer. This would be much easier to support on a WWW site. That much could be made permanent relatively easily.

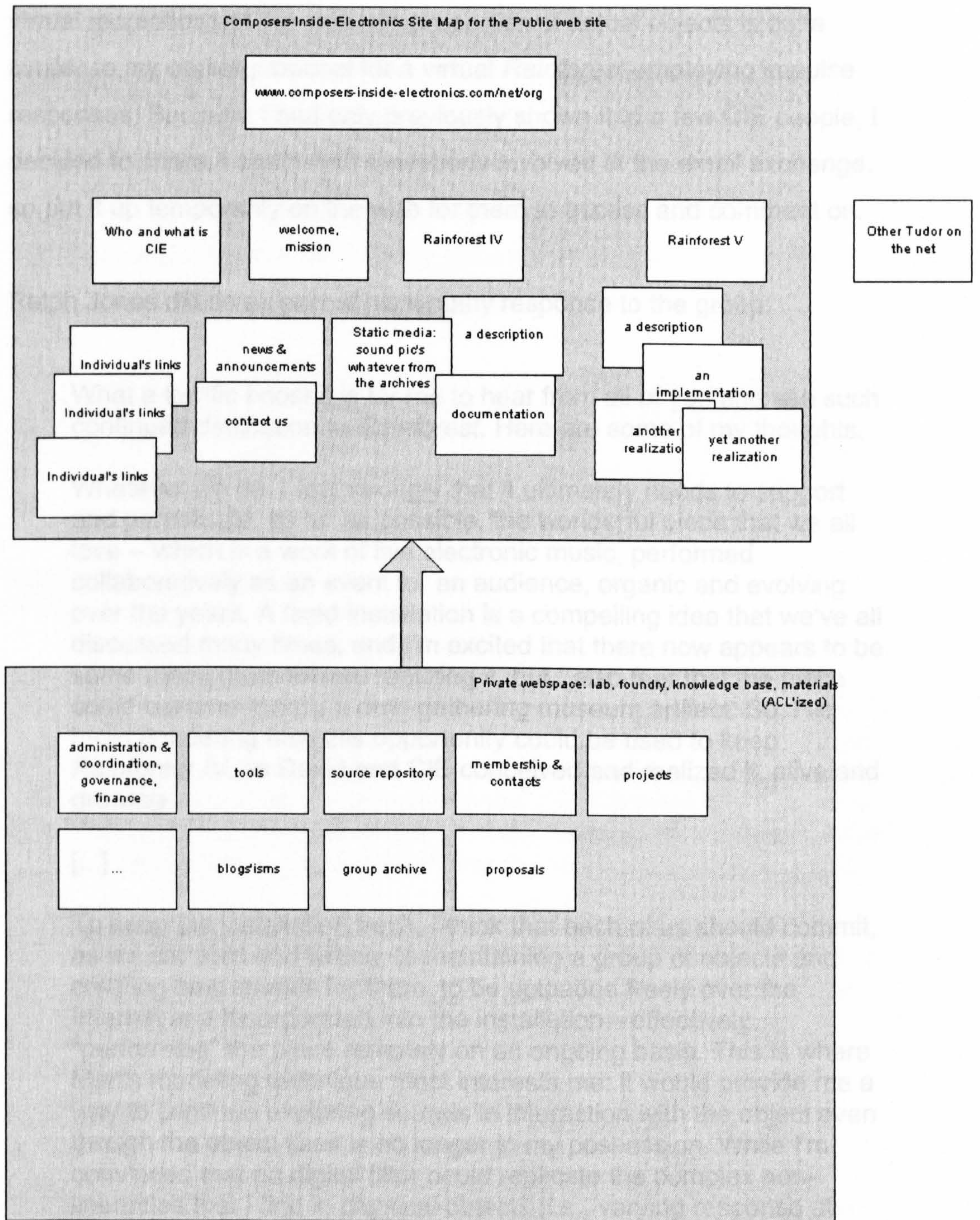

Figure 7-11. Diagram by Phil Edelstein of possible Composers Inside Electronics webspace. Note space for multiple implementations/realisations of "Rainforest V" (Edelstein 2005f).

The idea of a personalized, remote experience of *Rainforest 4* using virtual recreations of the acoustic properties of actual objects is quite similar to my earlier proposal for a virtual *Rainforest* employing impulse responses. Because I had only previously shown it to a few CIE people, I decided to share it again with everybody involved in the email exchange, so put it up temporarily on the web for them to access and comment on.

Ralph Jones did so as part of his lengthy response to the group:

What a terrific boost it is for me to hear from all of you and see such continued dedication to *Rainforest*. Here are some of my thoughts.

Whatever we do, I feel strongly that it ultimately needs to support and perpetuate, as far as possible, the wonderful piece that we all love -- which is a work of live electronic music, performed collaboratively as an event for an audience, organic and evolving over the years. A fixed installation is a compelling idea that we've all discussed many times, and I'm excited that there now appears to be some momentum toward realizing it, but I also fear that the piece could become merely a dust-gathering museum artifact. So, I've been pondering how this opportunity could be used to keep *Rainforest IV*, as David and CIE conceived and realized it, alive and growing.

[...]

To keep the installation fresh, I think that each of us should commit, as we are able and willing, to maintaining a group of objects and creating new sounds for them, to be uploaded freely over the Internet and incorporated into the installation—effectively "performing" the piece remotely on an ongoing basis. This is where Matt's modeling technique most interests me: it would provide me a way to continue exploring sounds in interaction with the object even though the object itself is no longer in my possession. While I'm convinced that no digital filter could replicate the complex nonlinearities that I find in physical objects (i.e., varying response at different drive levels), it could nevertheless provide a close enough approximation that I could work with confidence. (I would need separate impulse responses taken with a contact mike and a proximate air mike.) I love this idea, because I could have continuing involvement with the piece without having to find space in my little house to hang objects. Workshop graduates could also participate in this way, eventually even taking over responsibility for one or more objects.

(Jones 2005a)

Jones also envisioned a permanent, fixed installation as "an efficient means for training new performers. The beauty of this would be that the objects are already chosen and implemented, there is a body of example sounds, and there's a vivid embodiment of the realized work". A certain conservatism influenced Jones' thinking, however; the same impulse, perhaps, which was behind Tudor's remark that he wished to "protect" his piece (Tudor 1995) even as he "gave it away" in 1973:

I do not believe that the uninitiated should be invited to upload sounds at will. For me, this would serve no useful purpose and would only degrade the integrity of the piece. *Rainforest* is not a toy for idle tinkering: it takes real skill to do it right. (Jones 2005a)

Ultimately, Jones wrote,

I confess that I'm skeptical about Internet applications of the piece beyond what I've outlined here (upload access for CIE members), other than documentation. [...] in my experience, the Internet is an attention-deficit medium that offers only limitations to *Rainforest IV*. I can't conceive that, for the foreseeable future, the browser and all the attendant multimedia technologies could provide anything more than an extremely pale reflection of the *Rainforest* experience. After all, we don't even have control over the speakers on the user end.

Okay, stick web cams in the space, provide a streaming binaural feed, etc., but let's not pretend that this could ever take the place of a live performance—or even approximate the experience. Instead, I'd rather use the Web as a vehicle to promote new bookings.

(Jones 2005a)

Ron Kuivila concurred, replying "Indeed! The WWW presence could be simply a way to intensify the significance of the physical installation", but also raised an interesting question:

Also, why is the focus on *Rainforest IV* alone? In his notations, David enumerated a number of different approaches to the object/loudspeaker idea. For example, routing single sources to multiple objects is mentioned (and was actually done with Cage's

voice). When the piece was made, most of these other approaches were not practical for a large number of performers.

More music might result from revisiting earlier versions as a way to open new possibilities than from attempting to configure *Rainforest* as a pure WWW presence.

(Kuivila 2005)

John D.S. Adams responded that

The other incarnations of *Rainforest* [...] would definitely have to become an important part of a *Rainforest* web site. Historically, it is very important information and needs to be a part of the educational component of this whole venture. Yes, perhaps it could inspire new possibilities. (Adams 2005b)

Adams also raised the idea that potential European hosts for a permanent *Rainforest* installation ought to be considered, given the history of support for *Rainforest 4* presentations in that region.

Ralph Jones also commented on the idea of working with earlier versions of *Rainforest*, and also brought the *Rainforest* "postscript", *Forest Speech*, into the equation:

Well, I focus on RF IV because it's the version I know best and because I feel it's a genuine masterpiece of 20th century music—arguably the most successful piece of live electroacoustic music in the history of the form. But I'd certainly be jazzed to learn about other versions from those of you with deeper experience than I have.

Another largely unexplored version, attempted once by CIE in a performance at The Kitchen, involved exciting objects in such a way as to produce voice-like formants. In my experience, this was difficult to achieve, and bears much deeper investigation than we (or at least I) were able to give it at the time.

(Jones 2005b)

Phil Edelstein made an attempt to summarize the discussion in a long email as follows:

Let me break format and add some quick general comments and a bit of a ramble....

I go so far as to say that we're mustering a fair level of interest.

I've been listening carefully to everyone's caution on getting caught up internet-wise and hearing a strong affirmation and affection of working with live real objects. (web-based—that's when you google rolen star and buy transducers on the web <http://www.richtechenterprises.com/> <http://www.invisiblestereo.com/>).

Seems like there's more interest in plentiful access to transducers and pickups and less concern about web farms and streaming audio. No matter that cassette machines are just slightly older than IP [Internet protocol]— sounds like RF-over-IP will have to wait a little bit—not a problem. I'm thinking that the internet may give us some opportunities for collaboration at a distance—a poor substitute for a good barn dance on a warm summer evening to the murmur of heterodyning crickets—the smell of musty cider barrels—the counterpoint of soldering resin and retsina. Matt's Kingston scenario gets on my map. [...] i'm a bit prone to head off on the infrastructure track though i'll see if i can contain myself until a more opportune time.

I've forwarded JohnD a bit of a brain dump on what I'll call structural and administrative thoughts for (re-)building and extending a base of operations. We [Edelstein and Driscoll] had a good bit of a get together on Sunday evening—it's been a while since we've had a chance to catch up—seems like we're both finding a bit more time to return to thoughts of some *rainforest* style farming. We've dusted off an earlier iteration where we started getting our thoughts around updated project plan (from 1996) [the Thundergulch proposal] —i spent a few days rummaging a new list of links to mine for opportunities. I'm hoping we'll have something interesting to send out in a week or so. One of the cryptic notes in my jottings was kind of a regional view (parallels JohnA's comment of a European based permanent installation). It's one of those micro epiphanies for me realizing that we're talking about multiples (followed by a homer-simpson'ish *duh* - like i wonder where i got that from)..

Personally, I find the multiple version idea as a long term appealing operating model—I'm comfortable with a garden of forking delights (and have been tempted to fabricate the long lost dialog between David and Borges but that's for another night). Forgive me for bit of grandiosity, but my interests run to sustainability—the ability to

mutate and stay true to the form and spirit has always been one of the aspects of the piece(s) i've terrifically enjoyed. I like the idea of hearing CIE as a RF foundry of sorts. I'm doing a lot of word lists these days—architecture, extensability, adaptability, a trilogy of workbook, scrapbook cook book. At the risk of swimming the deepend of Matt's lake—i keep coming back to projecting a laboratory of system architecture through rainforest variations . i just hope that my obsession with rainforest infrastructure can be productively channeled (you can take the boy out of the country...).

(Edelstein 2005g)

This was the last group communication for more than a month; D'Arcy Gray then added his opinion in June 2005, echoing the call for a "proper" installation of the piece, at Mass MOCA or elsewhere, to function as a focus for brainstorming "in person the many thoughts, concerns, and ideas for the evolution into a permanent installation" (Gray 2005). I had already weighed in with description of a venue I thought of as being close to perfect for such a brainstorming session: a farm property north of Kingston, Ontario, run by a musician friend and equipped not only with a full recording studio and house to accomodate people, but also a barn ideal for hanging *Rainforest* objects—much as at the Chocorua workshop in 1973. The property also included a good swimming lake (which explains the "lake" reference in the Edelstein quotation above) and 200 acres of undeveloped land, promising for field recording expeditions. I had been imagining a *Rainforest* workshop on that site for the previous year, and now began to think of such a workshop in terms of the "brainstorming" session that might benefit CIE.

Following D'Arcy Gray's email to the group on June 24 2005, discussion fell silent again, following the pattern of bursts of intense CIE activity followed by long quiescent periods which can be seen over the entire history of the group, but especially since David Tudor's death.

The email exchanges of May-June 2005 were, however, the most significant roundtable CIE discussion regarding the long-term future of the group and *Rainforest* which had been achieved since Tudor's passing.

Although it was a "virtual" gathering of individuals connected with the project, it fulfilled some of the objectives of meetings that had failed to come together in earlier years, allowing each person to set forward their own prioritisation of issues, and their suggestions for useful avenues of exploration. The distillation I made of the discussion includes these points:

- Any "permanent" installation of *Rainforest* needs to acknowledge the history of the piece as a live performance event, with players sharing physical space with the installation, even if only occasionally.
- "Virtual" experiences of *Rainforest* should be explored as possibly useful auxiliary means of providing a wider audience with an appreciation of various aspects of the piece.
- Movement toward new version(s) of *Rainforest* would be aided by a gathering of CIE "family members" over at least several days, specifically called to facilitate discussion of possibilities and problems, rather than trying to tack on such a discussion to a full-blown public performance of *Rainforest 4*.
- A "brainstorming" session over a period of several days would, however, be aided by having reference to an installation of *Rainforest 4*, either set up by and for the discussion participants, or constructed in a workshop situation running parallel to the CIE discussion group. The installation would function as a point of reference, and a site for experimentation with ideas extending towards a "*Rainforest 5*", including those raised in informal discussions since 1996.

The email roundtable discussion recounted above took place in May and June 2005, and since that time, there has been little in the way of concrete developments towards a *Rainforest 5*.

Groundwork has now been laid to address points three and four above, however: as of March 2006, the barn site near Kingston, Ontario has been tentatively booked for a Composers Inside Electronics gathering to be held over ten days in August 2006 (funding has been solicited from the Daniel Langlois Foundation but is not yet secured). Several members of

the original group have thus far committed to attending: John Driscoll, Phil Edelstein and Ralph Jones. Ron Kuivila, John D.S. Adams and D'Arcy Philip Gray are also able to attend. The structure of the ten days will include a *Rainforest 4* workshop, to be offered to paying participants with the invited CIE artists as instructors. The workshop will take place in the morning, with the afternoon then given to CIE discussions, presentations, demonstrations of possible new technological innovations which could be applied to *Rainforest*. The intended result of this series of afternoon "brainstorming" sessions is twofold: first, to define a set of goals in finding a site for a permanent installation of *Rainforest* (identifying specific institutions which would be worth approaching for support, and CIE individuals who may have useful connections with those institutions); second, to identify several specific directions in which to pursue a *Rainforest 5*, following on Phil Edelstein's "garden of forking delights" comment, and to define a timeline for completing some initial research projects, with a commitment to meet again to evaluate the outcomes of our "assignments".

This kind of definition of roles and projects seems critical for the future of *Rainforest*, if it is to remain a lively site of experimental activity. Because all members of the original and extended Composers Inside Electronics family have significant obligations besides David Tudor's *Rainforest 4*, there is a tendency for the group to expend a lot of energy in short bursts, whenever an installation of the piece is mounted, and then return to a more or less quiescent state. This could be said to have been the case throughout the history of CIE and *Rainforest 4*, but is more pronounced now, with longer gaps of time between installations and lack of administrative support such as formerly provided by Performing Artservices. Focus on short-term, achievable goals, as steps towards realisation of long-term projects, may help in advancing some of the ideas for *Rainforest's* future which now date back to 1996.

The future of *Rainforest* as a piece in motion

David Tudor's performance practice was built upon constant change. Gordon Mumma, who traveled and performed extensively with Tudor during his 1960s transition from pianist to electronic musician, has emphasized this numerous times in my communications with him: "David could never stop changing things in his work. He wasn't one who 'nailed things down' " (Mumma 2001f); "David's creative process: his compositional work was ongoing process, not really 'product' in character". (Mumma 2001a); "Tudor's working sketches [...] weren't necessarily 'diaries' or 'scores' but reminders for him about where he might start for doing something different the next time—a 'starting point' from which NOT TO DO THE SAME THING AS BEFORE" (Mumma 2005b).

As I have stated earlier in this thesis, the separation of *Rainforest* into numbered stages—what Mumma referred to as the "slippery chronology of the 'versions' of RF" (Mumma 2001a)—is a somewhat artificial device, but it is one which Tudor found useful, and I have certainly found it useful in structuring a history of the piece. For all its usefulness, it may be too restrictive a model for the future(s) of *Rainforest*; we should remember that it was only long after the four "versions" of *Rainforest* to date had been created, to satisfy different demands at different times, that Tudor identified them as important way stations along a road of constant experimentation.

To predetermine a single, newly proposed formulation of *Rainforest* as "*Rainforest 5*" would seem to be contrary to the history of Tudor's exploration of objects-as-loudspeakers, in which significant moments in the trajectory of that work were identified only in hindsight. If the proposed 2006 gathering of Composers Inside Electronics comes to pass, we will inevitably find ourselves discussing what "*Rainforest 5*" *will be* or *could be*. The best we could do for the piece, however, might be to set the limitations of the title "*Rainforest 5*" to one side and simply follow our

ears. Given enough time for exploration of many possible futures for *Rainforest*, perhaps one or several interesting paths will appear which may eventually seem to warrant formal identification as the "next step".

Rainforest, from 1968 to the present, has been a solo performance, a duo performance, and a large collective performance; it has admitted of pre-recorded, "live-electronic", and live instrumental (vocal) sound sources; it has been performed with dance, as a concert piece, in conjunction with sound poetry, and as a performed installation; its dimensions have been very small and very large; its loudspeaker-instruments have been prosaically modest found objects and extravagantly sculptural constructions. This is a remarkable diversity to have sprung from an essentially simple concept, that sounds might be transformed by passing them through "acoustic filters", or "an orchestra of loudspeakers all having different 'voices' " (Tudor 1984). Also remarkable is the fact that each stage of the piece sounds unmistakably like *Rainforest*, from the minimalist first performance with dance in 1968, to the maximalist large group installations of 1998 and 2001. In this way it is like the proverbial river you can never step into twice: it remains the same while constantly changing. Tudor's idea was strong enough to hold the attention of a large number of younger artist-composer-performers, whose commitment to it seems to ensure that a lineage of "composers inside electronics" will continue to perform *Rainforest* and seek new ways to develop the piece, as opportunities present themselves. The work is identified with CIE but not limited to that group of players: just as I have been writing this conclusion I received an email announcing a new realisation of David Tudor's *Rainforest 4* in March 2006 as part of a new music festival in Birmingham, England (Wilson 2006). The fact that "anyone" can create a performance of *Rainforest*—it requires only the transducer technology and understanding of the basic loudspeaker-object concept— means that the most surprising developments could conceivably come from outside CIE and Tudor's network. Revisiting earlier versions of *Rainforest*—of versions 1, 2 and 3, I have thus far attempted versions 1 and 3, with varying results—may also prove to be valuable, both as a way of

acquiring a deeper understanding of Tudor's means and methods, and as a means of informing future research. The more that is understood about *Rainforest's* past—through practice—the richer its future may be.

Rainforest, in its various versions, will likely remain the most resilient of David Tudor's works, for the very reason that it is simple in concept and technology, and with "enough grace in it" (DeMarinis 2001) to maintain its identity even though performer experience and style may differ widely. Although the idea behind the piece is now more than 40 years old, *Rainforest 4's* most recent presentations by CIE illustrate that it continues to engage, surprise and instruct audiences, and, also because of its relatively non-specific terms of performance, resists becoming dated; it is continually refreshed. Its community of performers, which in a very real sense has grown up with the piece, feels the need to keep *Rainforest 4* a "living thing".

You have to realize that this is a very unique piece in the history of the field. [...] I felt after we did Lincoln Center that there was nothing lost after 20-some years in terms of how the audience received it, and that's a rare thing that you can continue a piece that long and it doesn't become dated. And I think part of that is the richness of it, and so I'd surely like to keep it going. And as I say it's not only the piece, the piece evolved as the group did.

John Driscoll
(Driscoll 2000a)

In conclusion

One of *Rainforest's* strengths, as a work which may be perpetuated and continually performed and extended, is that it is based on a single, simply explained idea: the use of physical objects as sonic filters. The complexity of the work, as evident in any of its versions, but particularly *Rainforest 4*, is that which is brought about in performance by the interplay of musical imaginations. Community and collaboration are at the core of this complexity. From *Rainforest 1* to *Rainforest 3*, the collaboration takes the form of a duet, or double performance: a community of two. With *Rainforest 4*, the community expanded to include a larger "family" of performers, an arbitrary number of whom can participate in the piece at any one time. This "family" is defined not only by its influence on *Rainforest*, although *Rainforest 4* forms a focal point for the group, but by *Rainforest's* influence on the creative output of its members, each of whom brought aspects of the piece into his or her own work in ways which were sometimes subtle, sometimes obvious.

Another layer of *Rainforest* "community" which is less immediately apparent includes the broader association of individuals who supported David Tudor's work on the piece through commissions, invitations, advocacy and technical expertise. As set out in this thesis, it seems likely that without these external factors occasioning and enabling continual re-invention of *Rainforest*, the piece would not have traveled to the places it did, conceptually or geographically.

The introductory chapter of this thesis opened with this statement from David Tudor: "I'd like to see the whole social situation change in regard to electronic music" (WBFO 1978). Although from the context of the interview it is clear that Tudor was referring to the culture of listening, and developing an audience for CIE's forms of music, it is also the case that with *Rainforest 4* Tudor presented a social model for collaborative music-making which was fairly unique. CIE may certainly be compared with other co-operative electronic/electroacoustic performance ensembles of

its era such as Taj Mahal Travelers, Sonic Arts Union, Musica Elettronica Viva, and the Canadian Electronic Ensemble, but *Rainforest 4*, as an open-ended performed installation of sound sculptures, stands quite apart from any work which was produced in the context of these other groups, and remains an anomalous project.

Aspects of other works created within CIE have become familiar territory for those working in electroacoustic collaboration, however, particularly the notion of "interfeed": sound and data exchange between players as an essential aspect of improvisational performance. CIE's "interfeed" prefigured the interest in computer network ensembles which took root in the later 1970s and the 1980s, beginning with the League of Automatic Music Composers, which morphed into The Hub. With the growth of the Internet as a performance medium, this type of connectivity has become a part of the standard toolkit for "live-electronic" music: for instance the popular audio programming environment Max/MSP includes a UDP (User Datagram Protocol) object for network transmission of data, and the latest version of the audio DSP programming language SuperCollider is built on the concept of a software synthesis machine which receives commands from a client application which may be anywhere on an attached network. Exchanging audio across the Internet, performing in geographically distributed ensembles, was considered to be on the artistic frontier as recently as the year 2000, with collaborative endeavours such as Sensorband and Jesse Gilbert's *Finding Time* project pushing the limits of the available technology. Now in 2006, video and audio chat software is commonly built into computer operating systems and many of the technical obstructions to this type of interchange have been removed. Aesthetic challenges remain, however.

This thesis is an effort to describe the totality of *Rainforest*, as a project which ran through David Tudor's entire "second career" as a composer-performer of live electronic music. Its chronological structure, while a

conservative way of representing this history, has seemed to be the clearest means of accessing the large amount of archival and interview material which, taken together, begins to provide a picture of the changes to which Tudor's core idea for the piece were subjected, and the intertwined energies of the large number of people who participated in this process. My engagement with individuals who worked with Tudor has been key; speaking with them, performing with them, and documenting their stories was a way of coming to an understanding of how individual life trajectories were woven together, with David Tudor and *Rainforest* being points of connection. It would have been far more difficult to read the social networks surrounding *Rainforest 4*, for instance, without the oral histories offered by its performers. Oral histories were also invaluable in clarifying matters of performance practice: neither Tudor's diagrams, nor performance recordings of *Rainforest*, provide a sufficient window into how performers individually or collectively approached the piece.

As a final note, I dwell for a moment on my own recent connections with CIE as performer and researcher. The former role—the challenge and enjoyment of joining in the continuation of David Tudor's work with the group—is what has continued to feed my enthusiasm for the project of tracing *Rainforest's* history. My participant-observer status seems likely to remain such, although the conclusion of this thesis will occasion changes in this relationship which I cannot necessarily predict. I look forward, however, to participating in the future of *Rainforest*, as well as continuing to learn about its past.

Appendix

Rainforest 1: performances 1968-2003, with
Merce Cunningham's dance RainForest (1968)

This list is based on a query to the Cunningham Dance Foundation's database of Merce Cunningham Dance Company performances. Following initial presentations between 1968 and 1972, there have been three revivals of the dance *RainForest*, visually identified by a dashed line. From 2003 to present (April 2006), *RainForest* has not been in the Company's repertory.

Note that *Rainforest 1* has usually been referred to simply as *Rainforest* in connection with Cunningham's dance.

State University of New York, Buffalo, NY 03/09/1968
State University College, Oneonta, NY 03/21/1968
State University College, Fredonia, NY 04/01/1968
Harper Theater, Chicago, IL 04/23/1968
Harper Theater, Chicago, IL 04/26/1968
Harper Theater, Chicago, IL 04/28/1968
Harper Theater, Chicago, IL 04/28/1968
Bradley University, Peoria, IL 05/04/1968
Brooklyn Academy of Music, New York, NY 05/15/1968
Brooklyn Academy of Music New York, NY 05/23/1968
Brooklyn Academy of Music, New York, NY 05/26/1968
University of Colorado, Boulder, CO 07/12/1968
Teatro de Bellas Artes, Mexico City, D F Mexico 07/15/1968
Teatro de Bellas Artes, Mexico City, D F Mexico 07/16/1968
Teatro de Bellas Artes, Mexico City, D F Mexico 07/20/1968
Teatro Novo, Rio de Janeiro, Brazil 07/30/1968
Teatro Novo, Rio de Janeiro, Brazil 07/31/1968
Teatro San Martin, Buenos Aires, Argentina 08/10/1968
Teatro Municipal, Caracas, Venezuela 08/14/1968
University of California, Santa Cruz, CA 11/07/1968
University of California, Davis, CA 11/13/1968
University of California Los Angeles, Los Angeles, CA 11/15/1968
University of California, San Diego, CA 11/17/1968
Billy Rose Theater, New York, NY 01/13/1969
Billy Rose Theater, New York, NY 01/15/1969
Billy Rose Theater, New York, NY 01/16/1969
Staten Island Community College, Staten Island, NY 02/26/1969
Nazareth College, Rochester, NY 03/04/1969
Cornell University, Ithaca, NY 03/07/1969
Kiel Opera House, Saint Joseph, MO 03/15/1969
University of Wisconsin, Milwaukee, WI 03/19/1969
Rosary College, River Forest, IL 03/21/1969
Harper Theater, Chicago, IL 03/25/1969
Harper Theater, Chicago, IL 03/30/1969
Harper Theater, Chicago, IL 03/30/1969

Brooklyn Academy of Music, New York, NY 04/16/1969
 Teatro Sistina, Rome, Italy 04/23/1969
 Macalester College, Saint Paul, MN 09/19/1969
 Tyrone Guthrie Theatre, Minneapolis, MN 09/28/1969
 Brooklyn Academy of Music, New York, NY 01/09/1970
 Brooklyn Academy of Music, Brooklyn, NY 01/12/1970
 Brooklyn Academy of Music, New York, NY 01/13/1970
 University of Connecticut Storrs, CT 02/13/1970
 University of Massachusetts, Amherst, MA 02/18/1970
 Boston University, Boston, MA 02/22/1970
 Lisner Auditorium, Washington, D.C. 02/25/1970
 Syria Mosque Pittsburgh, PA 03/07/1970
 University of South Florida, Tampa, FL 03/20/1970
 Théâtre de France, Paris, France 06/03/1970
 Théâtre de France, Paris, France 06/04/1970
 Théâtre de France, Paris, France 06/08/1970
 Théâtre de France, Paris, France 06/08/1970
 Théâtre de France, Paris, France 06/09/1970
 Théâtre de France, Paris, France 06/12/1970
 Théâtre de France, Paris, France 06/13/1970
 Théâtre de France, Paris, France 06/15/1970
 Théâtre de France, Paris, France 06/22/1970
 Stadsschouwburg, Amsterdam, Holland 06/23/1970
 Stadsschouwburg, Eindhoven, Holland 06/24/1970
 Stadsschouwburg, Nijmegen, Holland 06/30/1970
 Teatro Nuovo, Spoleto, Italy 07/07/1970
 Teatro Nuovo, Spoleto, Italy 07/08/1970
 Teatro Nuovo, Spoleto, Italy 07/09/1970
 Teatro Nuovo, Spoleto, Italy 07/12/1970
 Fondation Maeght, Saint-Paul, France 07/17/1970 (*Event performance
 with David Tudor's Rainforest*)
 Brooklyn Academy of Music, New York, NY 11/03/1970
 Brooklyn Academy of Music, New York, NY 11/06/1970
 Brooklyn Academy of Music, New York, NY 11/08/1970
 Civic Theatre, Chicago, IL 01/12/1971
 Civic Theatre, Chicago, IL 01/17/1971
 University of California, Irvine, CA 01/29/1971
 University of Michigan, Ann Arbor, MI 04/13/1971
 Indiana University, Bloomington, IN 04/16/1971
 University of Wisconsin, Madison, WI 04/24/1971
 Brooklyn Academy of Music, New York, NY 02/02/1972
 Brooklyn Academy of Music, New York, NY 02/08/1972
 Teatro la Fenice, Venice, Italy 09/12/1972
 Teatro Toniolo, Mestre, Venice Italy 09/13/1972
 Atelier 212, Belgrade, Yugoslavia 09/19/1972
 Teatr Dramatyczny, Warsaw, Poland 09/22/1972
 Sadler's Wells Theatre, London, United Kingdom 09/30/1972
 Teatro Lirico, Milan, Italy 10/17/1972
 Théâtre de la Ville, Paris, France 10/29/1972

Boston English High School, Boston, MA 02/26/1978
Boston English High School, Boston, MA 03/01/1978
Murray Theatre Ravinia Festival, Ravinia, IL 08/23/1978
Murray Theatre Ravinia Festival, Ravinia, IL 08/25/1978
Murray Theatre Ravinia Festival, Ravinia, IL 08/27/1978
City Center Theater, New York, NY 09/30/1978
City Center Theater, New York, NY 10/03/1978
City Center Theater, New York, NY 10/07/1978
University of Colorado, Boulder, CO 10/31/1978
Duke University, Durham, NC 07/20/1979

National Museum of Natural History, Washington, D.C. 12/06/1981
Institute of Contemporary Arts, Boston, MA 11/09/1982
Joyce Theater, New York, NY 03/01/1988
Joyce Theater, New York, NY 03/25/1988
Joyce Theater, New York, NY 03/26/1988
Joyce Theater, New York, NY 03/27/1988
Teatro Sergio Cardoso, Sao Paulo, Brazil 04/08/1988
Teatro Sergio Cardoso, Sao Paulo, Brazil 04/09/1988
Teatro Sergio Cardoso, Sao Paulo, Brazil 04/11/1988
Teatro Sergio Cardoso, Sao Paulo, Brazil 04/12/1988
Palacio das Artes, Belo Horizonte, Brazil 04/15/1988
Freie Volksbuhne, Berlin, Germany 06/17/1988
Freie Volksbuhne, Berlin, Germany 06/19/1988
Theater der Stadt, Duisburg, Germany 07/01/1988
Opernhaus, Koln, Germany 07/03/1988
Duke University, Durham, NC 07/21/1988
Duke University, Durham, NC 07/23/1988
Palais des Papes, Avignon, France 08/02/1988
Palais des Papes, Avignon, France 08/04/1988
John Hancock Hall, Boston, MA 10/06/1988
Stanford Memorial Auditorium, Stanford, CA 10/14/1988
Armstrong Theatre, Colorado Springs, CO 10/18/1988
Opera, Chateaufallon Toulon, Toulon, France 11/19/1988
Maison de la Culture, Grenoble, France 11/23/1988
Maison de la Culture, Le Havre, France 12/02/1988
Théâtre de la Ville, Paris, France 12/26/1988
Théâtre de la Ville, Paris, France 12/27/1988
University of Texas, Austin, Texas 01/28/1989
Northrop Auditorium, Minneapolis, Minnesota 02/17/1989
City Center Theater, New York, New York 02/28/1989
City Center Theater, New York, NY 03/07/1989
City Center Theater, New York, NY 03/11/1989
Eisenhower Theater, Kennedy Center, Washington, DC 05/02/1989
Eisenhower Theater, Kennedy Center, Washington, DC 05/06/1989
Tilles Center for the Performing Arts, Brookville, New York 05/12/1989

Sadler's Wells Theatre, London, United Kingdom 10/31/1989
Sadler's Wells Theatre, London, United Kingdom 11/01/1989
Sadler's Wells Theatre, London, United Kingdom 11/02/1989
Madison Civic Center, Madison, Wisconsin 02/04/1990
Ohio State University, Columbus, OH 02/17/1990
City Center Theater, New York, NY 03/14/1990
City Center Theater, New York, NY 03/17/1990
Siri Fort Auditorium, New Delhi, India 11/02/1990
Siri Fort Auditorium, New Delhi, India 11/03/1990
Rabindra Sadan, Calcutta, India 11/08/1990
Rabindra Sadan, Calcutta, India 11/09/1990
Rabindra Kalakshetra, Bangalore, India 11/13/1990
Rabindra Kalakshetra, Bangalore, India 11/14/1990
Homi Bhabha Auditorium, Bombay, India 11/17/1990
Homi Bhabha Auditorium, Bombay, India 11/18/1990

Volkstheater Wien, Vienna, Austria 07/29/2000
Barbican Centre, London, United Kingdom 10/11/2000
Barbican Centre, London, United Kingdom 10/12/2000
Teatro de la Zarzuela, Madrid, Spain 11/24/2000
Théâtre de Caen, Caen, France 12/06/2000
Théâtre National de Toulouse, Toulouse, France 12/13/2000
Comedie de Reims, Reims, France 12/16/2000
Burswood Theatre, Perth, Australia 02/03/2001
Mandurah Performing Arts Centre, Perth, Australia 02/05/2001
City Center Theater, New York, New York 03/31/2001
City Center Theater, New York, New York 04/06/2001
Meany Theater, Seattle, Washington 04/26/2001
Meany Theater, Seattle, Washington 04/27/2001
Meany Theater, Seattle, Washington 04/28/2001
Arlene Schnitzer Hall, Portland, Oregon 05/02/2001
Zellerbach Hall, Berkeley, CA 05/05/2001
Rivoli Teatro Municipal, Porto, Portugal 05/20/2001
Rivoli Teatro Municipal, Porto, Portugal 06/20/2001
Het Muziektheater, Amsterdam, Netherlands 06/29/2001
Het Muziektheater, Amsterdam, Netherlands 06/30/2001
Opera Berlioz, Le Corum, Montpellier, France 07/03/2001
Duke University, Durham, North Carolina 07/12/2001
Duke University, Durham, North Carolina 07/13/2001
Duke University, Durham, North Carolina 07/14/2001
Théâtre de la Ville, Paris, France 11/13/2001
Théâtre de la Ville, Paris, France 11/14/2001
Théâtre de la Ville, Paris, France 11/15/2001
Théâtre de la Ville, Paris, France 11/16/2001
Théâtre de la Ville, Paris, France 11/17/2001
Bremer Theater, Bremen, Germany 03/16/2002
Bremer Theater, Bremen, Germany 03/17/2002
Auditorium, Dijon, France 03/22/2002

Auditorium, Dijon, France 03/23/2002
The National Theatre, Dublin, Ireland 05/10/2002
The National Theatre, Dublin, Ireland 05/11/2002
Reykjavik City Theatre, Reykjavik, Iceland 09/24/2002
Staatstheater am Gartnerplatz, Munich, Germany 10/30/2002
Deutsches Nationaltheater and Staatskapelle, Weimar, Germany
11/03/2002
Carlsen Center, Overland Park, Kansas 02/14/2003

Rainforest 3:
Performances by David Tudor
as part of European tour with John Cage, 1972

All of Tudor and Cage's collaborative performances on this tour, including those which did not feature *Rainforest 3*, are included in this list.

A recording of the premiere performance of *Rainforest 3* with *Mureau* on May 5 1972 has been released on CD (New World Records 80540-2), with Tudor's contribution erroneously identified as *Rainforest 2*.

Note that *Rainforest 3* was referred to simply as *Rainforest* in publicity and programme materials for this tour.

Grosser Glockensaal, Bremen, West Germany, May 5 1972
Rainforest 3 (Tudor) with *Mureau* (Cage)

Sendesaal, Bremen, West Germany, May 8 1972
Untitled (Tudor) with
Sixty-Two Mesostics re Merce Cunningham (Cage)

Landesgalerie, Bonn, West Germany, May 18 1972
Rainforest 3 (Tudor) with *Mureau* (Cage)

Royal Albert Hall, London UK, May 22 1972
Rainforest 3 (Tudor) with *Mureau* (Cage), and
Untitled (Tudor) with
Sixty-Two Mesostics re Merce Cunningham (Cage)

Stadt Theatre, Basel, Switzerland, June 5 1972
Rainforest 3 (Tudor) with *Mureau* (Cage)

ALEA Encuentros en Pamplona Festival, Pamplona, Spain,
July 2 1968
Rainforest 3 (Tudor) with *Mureau* (Cage)

Academy of Fine Arts, West Berlin, July 11 1972
Rainforest 3 (Tudor) with *Mureau* (Cage)

Philharmonic Hall, West Berlin, July 18 1972
HPSCHD (Cage/Hiller)

ICES Festival, The Roundhouse, London, UK, August 13
1972
HPSCHD (Cage/Hiller)

Bayerischer Rundfunk, Munich, West Germany, August 30
1972
Monobird (Tudor) with *Birdcage* (Cage)

Rainforest 4:
Major performances 1973-2005

Based on a draft list provided by John Driscoll, of *Rainforest 4* performances and performers.

Note that until 1980 *Rainforest 4* was referred to simply as *Rainforest* in publicity and programme materials.

Key to performers appearing more than once in list:

JDSA - John D.S. Adams	DPG - D'Arcy Philip Gray
DB - David Behrman	RJ - Ralph Jones
NC - Nicolas Collins	MK - Martin Kalve
JD - John Driscoll	TK - Takehisa Kosugi
PD - Paul DeMarinis	RK - Ron Kuivila
PE - Phil Edelstein	MR - Matt Rogalsky
LF - Linda Fisher	DT - David Tudor
RF - Russell Frehling	BV - Bill Viola

July 6 1973

Stafford's-in-the-Field, Chocorua NH

New Music in New Hampshire workshop

DT, JD, PE, LF, BV, MK, DB

Susan Palmer, Ritty Burchfield, Ann Sandifur

(presented under title *Sliding Pitches in the Rainforest in the Field*)

March 8 1974

Everson Museum, Syracuse NY

DT, JD, LF, BV

March 9 1974

Synapse, Syracuse NY (recording session)

DT, JD, LF, BV

May 12 1974

Buffalo State College, Buffalo NY

DT, JD, LF, MK, RJ

February 18 1975

Free Music Store, Albany NY

JD, PE, Kyle Keenan, Richard Kelly, George Kindler, Richard Lainhart

February 1975 (date of performance uncertain)

York University, Toronto Canada

DT, JD, MK, Richard Teitelbaum and students

April 9 1975
Mills College, Oakland CA
DT, JD, PE, PD, DB, Virginia Quesada, Ann Sandifur

April 19 1975
The Kitchen, New York City NY
DT, JD, MK, RJ, LF

October 16 1975
Fort Worth Art Museum, Fort Worth TX
JD, DT, local performers

November 18 1975
Los Angeles County Museum, Los Angeles CA
DT, JD, PE, BV

November 24 1975
De Saisset Museum, Santa Clara CA
DT, JD, PE, BV

February 4 1976
State University of New York, Postdam NY
DT, JD, BV, LF, PE, David Maswick

April 7 1976
Cobleskil State College, Cobleskil NY
JD, BV, LF, BV
(with workshop April 6)

June 5-6 1976
Contemporary Arts Museum, Houston TX
DT, JD, MK, BV, PE, RJ

June 14-15 1976
Walker Art Centre, Minneapolis MN
DT, JD, PE, BV

September 22 1976
Northern Illinois University, DeKalb IL
DT, JD, students

September 29 1976
Carpenter Center, Harvard University, Cambridge MA
DT, JD, PE, BV, LF

October 20 1976
Musée Galliera, Paris France
DT, JD, PE, LF, RJ, MK, PD, BV

November 2-6 1976
L'Éspace Pierre Cardin, Paris France
JD, DT, RJ, MK, PD, BV

November 20 1976
Recording session for Dance in America video series, New York City NY
DT, LF, MK, BV

January 25-February 8 (date(s) of performance uncertain)
Center for Music Experiment, University of California, San Diego CA
DT, JD, BV, PE, PD

March 1978 (date(s) of performance uncertain)
University of North Carolina, Chapel Hill NC
DT, MK, PE, RF

April 4-7 1979
Insitute of Contemporary Art, Philadelphia PA
DT, JD, PE, BV, Andrej Zrajic

January 11-13 1980
Moderna Museet, Stockholm Sweden
DT, JD, PE, MK, RJ

January 20-February 1 1980
Exhibition *Für Augen und Ohren*, Akademie Der Kunste, Berlin Germany
DT, JD, PE, RJ, MK, BV
First use of title *Rainforest 4* (although *Rainforest* also used in catalogue)

February 1981 (date(s) of performance uncertain)
University of Maryland, College Park MD
JD, PE

September 20-October 4 1981
Neuberger Museum, State University of New York, Purchase NY
DT, JD, PE, RJ, NC

June 5-13 1982
Stedelijk Museum, Amsterdam Netherlands
JD, DT, PE, MK, TK, NC, Cynthia Black

November 18 1995
Bard College, Annandale-on-Hudson NY
Student performance with DT in attendance

September 17 1996
David Tudor Memorial Celebration, Judson Memorial Church, New York
City NY
JD, PD, PE, LF, RJ, BV, RF, JDSA, DPG

July 13-20 1998

Clarke Studio Theatre, Lincoln Center, New York City NY
JDSA, PDM, JD, DPG, LF, RJ, RK, MR, Ben Manley

April 23-24 1999

The Music Gallery, Toronto Canada
JDSA, DPG, MR

May 17-19 2001

California Institute of the Arts, Valencia CA
JD, RJ, PD, BV, RK, JDSA, DPG, MR, Mark Trayle, students

May 25 2003

Spiral Hall, NTT Intercommunication Centre, Tokyo Japan
TK, Yamataka Eye, Izumi Kiyoshi

Composers Inside Electronics:
Engagements 1976-1982

The list below includes engagements (performance series and residencies) under the name Composers Inside Electronics, which featured works by the group other than *Rainforest 4* but may also have included *Rainforest 4*.

Note that until 1980 *Rainforest 4* was referred to simply as *Rainforest* in publicity and programme materials.

Festival d'Automne, Paris, October 20-26 1976

Performers: John Driscoll, Paul DeMarinis, Phil Edelstein, Linda Fisher, Martin Kalve, Ralph Jones, David Tudor, Bill Viola

Works performed:

October 20

Rainforest (David Tudor) (perf. all)

October 21

Piano Concert for David Tudor (Richard Maxfield) (perf. DT)

Sapporo (Toshi Ichiyanagi) (perf. all)

Cartridge Music (John Cage) (perf. all)

October 22

Molimo (Paul DeMarinis) (perf. PD MK)

Gong (Bill Viola) (perf. BV LF)

Interfeed (John Driscoll/Phil Edelstein) (perf. JD PE)

October 23

Microphone (David Tudor) (perf. DT LF)

Pulsers (David Tudor) (perf. DT)

October 25

Listening Out Loud (John Driscoll) (perf. JD PD BV)

Zabriskie Point (Phil Edelstein) (perf. PE + Marsha Heather Harris)
(version of *Shrieks and Nuptials*)

Et puis... et puis... est-ce que je puis? (Martin Kalve) (perf. MK + audience)

October 26

Catch Wave (Takehisa Kosugi) (perf. all)

Atlas Eclipticalis (John Cage) (perf. all)

Installation works presented throughout:

Circuitree (Ralph Jones)

Sources of Naturally-Occurring Ultrasonics (Ralph Jones)

Pygmy Gamelan (Paul DeMarinis)

The Kitchen, New York City, January 6-8 1977

Performers: John Driscoll, Phil Edelstein, Linda Fisher, Marsha Heather Harris, Martin Kalve, David Tudor, Bill Viola

Works performed:

January 6

Solo Synthesizer Music (Linda Fisher) (perf. LF, MK)

Pulsers (David Tudor) (perf. DT)

January 7

Solo Synthesizer Music (Linda Fisher) (perf. LF, MK)

Listening Out Loud (John Driscoll) (perf. JD, PE, BV)

Pulsers (David Tudor) (perf. DT)

January 8

Shrieks and Nuptials (Phil Edelstein) (perf. PE, MH)

Gong (Bill Viola) (perf. LF, BV)

Under the Putting Green (John Driscoll) (perf. JD)

University of California San Diego

Center for Music Experiment Residency January 25-February 8 1977

Participants: David Tudor, John Driscoll, Bill Viola, Phil Edelstein, Paul Demarinis

Included development of new loudspeaker objects and a performance of *Rainforest* but was otherwise used for research into topics such as computer delay lines (Edelstein) and rotating loudspeakers (Driscoll).

The Kitchen, New York City, September 20 - 23 1978

Performers: John Driscoll, Ralph Jones, Martin Kalve, David Tudor

Works performed (each performed by all four musicians every night):

September 20

Ebers and Mole (John Driscoll)

September 21

Star Networks at the Singing Point (Ralph Jones)

September 22

Earthing (Martin Kalve)

September 23

Forest Speech (David Tudor)

Focused Loudspeaker Research Residency
Media Study/Buffalo, Buffalo NY, November-December 1978

John Driscoll, Ralph Jones, Martin Kalve, David Tudor

Lecture-presentations:

November 12

"Design and Collaborative Composition", Ralph Jones

November 19

"Automated Puppetry", John Driscoll

November 26

"The Art of Playing Electronic Instruments", Martin Kalve

December 3

"Altering Signal Sources in Real Time", David Tudor

Dry Swimming Pool Residency

Media Study/Buffalo, Buffalo NY, May 1979

This residency was not billed as a CIE activity but three of the four participants were CIE members and some works produced during the residency were subsequently presented in CIE events.

Participants: John Driscoll, Ralph Jones, Yoshi Wada, Bill Viola

Performances May 7:

The Talking Drum (for Herman Heins) (Bill Viola) (perf. BV, RJ)

Bottom Coasting (John Driscoll) (perf. JD)

Dry Pool Soundings (Ralph Jones) (perf. RJ)

An Adapted Bag with Sympathy (Yoshi Wada)

Ars Electronica, Linz Austria, September 10-13 1980

Performers: John Driscoll, Phil Edelstein, Ralph Jones

Pieces performed ("several times daily"):

Star Networks at the Singing Point (Ralph Jones) (perf. RJ)

Dry Pool Soundings (Ralph Jones) (perf. RJ, JD)

Charmed Particles (John Driscoll with Phil Edelstein) (perf. JD, PE)

Terrain (Phil Edelstein) (perf. PE)

David Tudor and Lowell Cross also presented *Laser Concert* on September 10 (not a CIE event)

Holland Festival June 4 - 13 1982

Performers: Cynthia Black, Nicolas Collins, John Driscoll, Phil Edelstein,
Martin Kalve, Takehisa Kosugi, David Tudor

June 4, Centrum 't Hoogt, Utrecht

Baby Maybe Baby? (Martin Kalve) (perf. MK)

Catch Wave (Takehisa Kosugi) (perf. CB, NC, MK, TK)

June 5-13, Stedelijk Museum, Amsterdam

Rainforest IV (David Tudor) (perf. CB, NC, JD, PE, MK, TK, DT)

June 7, Bellevue Theatre, Amsterdam

Is she really going out with him? (Nicolas Collins) (perf. NC)

It's in them and it's just gotta come out (John Driscoll) (perf. JD,
TK, DT)

Baby Maybe Baby? (Martin Kalve) (perf. MK)

June 9, Bellevue Theatre, Amsterdam

Untitled (David Tudor) (perf. DT)

Papermusic (Phil Edelstein and Cynthia Black) (perf. CB, PE)

Baby Maybe Baby? (Martin Kalve) (perf. MK)

**COMBINED BIBLIOGRAPHY
AND LIST OF REFERENCES**

In this list, COMPOSERS INSIDE ELECTRONICS is referred to by the abbreviation CIE. EXPERIMENTS IN ART AND TECHNOLOGY is referred to by the abbreviation E.A.T.

ADAMS, J.D.S., 1997a. Spirit Beyond a Life. *MusicWorks*, 69, 13.

ADAMS, J.D.S., 1997b. Giant Oscillations: The Birth of *Toneburst*. *MusicWorks*, 69, 14-17.

ADAMS, J.D.S., 1998a. Email to the author on September 15.

ADAMS, J.D.S., 1998b. Email to the author on July 30.

ADAMS, J.D.S., 2001. Email to the author on June 4.

ADAMS, J.D.S., 2005a. Email to the author on June 10.

ADAMS, J.D.S., 2005b. Email to the author on May 16.

ADAMS, J.D.S. AND GRAY, D.P., 1997. *David Tudor, Fluorescent Sound* [online]. Electronic Music Foundation. Available from: <http://www.emf.org/tudor/About/fsound.html>

AMACHER, M., 2000. Telephone interview with the author on May 22. [Recording in possession of author]

ARS ELECTRONICA, 1980. *Ars Electronica 1980 catalogue and programme book* [online]. Ars Electronica. Available from: http://www.aec.at/de/archives/festival_archive/festival_overview.asp?iPresentationYearFrom=1980

ASHLEY, R., 1964. Score for *Wolfman*. *Source Magazine*, 3, 6.

Ashworth Sound Reproducer instruction sheets. Los Angeles: David Tudor Papers, Getty Research Institute, acquisition no. 980039, box 36 folder 3.

AUSTIN, L., 1989. *David Tudor and Larry Austin: A Conversation, April 3, 1989, Denton, Texas* [online]. Electronic Music Foundation. Available from: <http://www.emf.org/tudor/Articles/austin.html>.

AUSTIN, L., 1996. In memoriam, David Tudor. *Array* (newsletter of the International Computer Music Association) [online], Fall/Winter 1996. Available from: http://www.computermusic.org/members_only/array_issues/fallwinter96/feature_articles.html.

BARKER-MILL, A., 1999. David Tudor's Sound Table. *MusicWorks*, 73 (Spring), 24-25.

BARNES, T.J., 2001. Lives lived and lives told: biographies of geography's quantitative revolution. *Environment and Planning D: Society and Space*, 19, 409-429.

BECKERS, G.J.L., SUTHERS, R.A., AND TEN CATE, C., 2003. Mechanisms of frequency and amplitude modulation in ring dove song. *The Journal of Experimental Biology*, 206, 1833-1843.

BEHRMAN, D., 1966. Score for *Wave Train*. *Source Magazine*, 4, 10-14.

BEHRMAN, D., 1997. Tudor. *MusikTexte*, 69/70 (April), 73-75.

BEHRMAN, D., AND KUIVILA, R., 1998. Composing with Shifting Sand: A Conversation between Ron Kuivila and David Behrman on Electronic Music and the Ephemerality of Technology. *Leonardo Music Journal*, 8, 13-16.

BENNET-CLARK, H.C., 1999. Resonators In Insect Sound Production: How Insects Produce Loud Pure-Tone Songs. *The Journal of Experimental Biology*, 202, 3347-3357.

Blavatsky, Helena Petrovna (1831-91) [online]. Occultopedia. Available from: <http://www.occultopedia.com/b/blavatsky.htm>.

BLAVATSKY, H.P., 1896. *The Mind in Nature* [online]. Theosophy Northwest. Available from: <http://www.theosophy-nw.org>.

BORDEN, D., undated. *Mother Mallard's Portable Masterpiece Co.: History—the early years* [online]. Available from: <http://www.mothermallard.cornell.edu>.

BURCHFIELD, R., 2002. Interview with the author on May 10, New York NY. [Recording in possession of author]

BURCHFIELD, R., 2005. Email to the author on 22 July.

CAGE, J., UNDATED A. Letter ca. early 1950s, to David Tudor and Mary Caroline Richards. Los Angeles: David Tudor Papers, Getty Research Institute, acquisition no. 980039, box 52 folder 3.

CAGE, J., UNDATED B. Untitled manuscript, identifiable by large format paper with computer printout hexagrams on one side and typewritten text on the other. Middletown: Wesleyan University Special Collections.

CAGE, J., UNDATED C. Undated manuscript circa 1971 (in close proximity to manuscript of *Mureau*). Middletown: Wesleyan University Special Collections.

CAGE, J. UNDATED D. Note on *Mureau*, found in folder "JC-DT Itineraries and Travel". New York: Performing Artservices papers, John Cage Trust.

CAGE, J., 1957. Experimental Music. *In: Silence: Lectures and Writings by John Cage*. Middletown: Wesleyan University Press, 7-13.

CAGE, J., 1960. Score for *Cartridge Music*. Editions Peters, EP6703.

CAGE, J., 1961. *Silence: Lectures and Writings by John Cage*. Middletown: Wesleyan University Press.

CAGE, J., 1966. Note to David Tudor. Los Angeles: Tudor Papers, Getty Research Library, acquisition no. 980039, box 1 folder 11.

CAGE, J., 1968. Note-o-gram to Hugh LeCaine, October 4. Evanston: John Cage Correspondence Collection, Northwestern University Library, item C41A.29.

CAGE, J., 1971a. Cage-Otte correspondence Feb 11 1971. New York: Performing Artservices papers, John Cage Trust.

CAGE, J., 1971b. Cage-Otte correspondence April 29 1971. New York: Performing Artservices papers, John Cage Trust.

CAGE, J., 1971c. Cage-Otte correspondence July 27 1971. New York: Performing Artservices papers, John Cage Trust.

CAGE, J., 1971d. Correspondence with Radio Bremen circa 1971. New York: John Cage Trust.

CAGE, J. 1972. Notes on performance setup for *Mureau* found in folder "JC-DT Itineraries and Travel". New York: Performing Artservices papers, John Cage Trust.

CAGE, J., 1975. *A Year from Monday*. Middletown: Wesleyan University Press.

CAGE, J., 1981. *For the Birds*. London: Marion Boyars.

CAGE, J., 1984. Memo to David Tudor March 23 1984 proposing a Tudor biographical project. Los Angeles: David Tudor Papers, Getty Research Institute, acquisition no. 980039, box 52 folder 3.

CAGE, J., 1991. An Autobiographical Statement [online]. New Albion Records. Available from: <http://www.newalbion.com/artists/cagej/autobiog.html>.

CAGE, J. AND TUDOR, D., 1992. *Indeterminacy : New Aspect of Form in Instrumental and Electronic Music. Ninety Stories by John Cage, with Music*. CD. Smithsonian/Folkways. DF 40804/5.

CAGE, J., AND BOULEZ, P., 1993. *The Boulez-Cage Correspondence*. NATTIEZ, J., AND SAMUELS, R., eds. Cambridge: Cambridge University Press.

CAGE, J., AND FELDMAN, M., 1993. *Radio Happenings: Conversations*. Köln: MusikTexte.

CAMERON, L., 1997. *Openings: A Meditation on History, Method and Sumas Lake*. Montréal: McGill-Queen's University Press.

CAMERON, L., 2001. *Anthropogenic natures: Wicken Fen and histories of disturbance, 1923-43*. Thesis (PhD). University of Cambridge.

CARROL COUNTY INDEPENDENT, 1973. We just do music, music which we feel is necessary to do now. June 28, 1-3.

CHADABE, J., 1993. *David Tudor interviewed by Joel Chadabe, Tompkins Cove Sept. 8 1993* [online]. Electronic Music Foundation. Available from: <http://www.emf.org/tudor/Articles/chadabe.html>

CHADABE, J., 1997. *Electric Sound: The past and promise of electronic music*. Upper Saddle River: Prentice Hall.

CHAUDRON, A., 2002. *Mureau* [online]. John Cage Database. Available from: <http://www.johncage.info/index2.html>

CLOSE, ROY M., 1976. 'Rainforest' isn't music, it's musical. *The Minneapolis Star*, June 14, 2B.

COLLINS, N., 1995. *Interview with Brian Duguid* [online]. Available from: <http://media.hyperreal.org/zines/est/intervs/collins.html>

COLLINS, N., 1997. Gain. *MusikTexte*, 69/70 (April), 95.

COLLINS, N., 2005. *Searching for the Perfect Beep* [online]. Available from: http://www.okno.be/old/en/press/collins_paper.html

COLLINS, N., 2006. Email to the author on January 24.

CIE, 1976a. English versions of program notes for compositions and installations presented at the Festival d'Automne. Obtained from the personal archive of John Driscoll.

CIE, 1976b. French-language programme book for the Festival d'Automne. Obtained from the personal archive of Phil Edelstein. All quoted translations by M Rogalsky.

CIE, 1976c. "Technical sheet - to be provided by the Festival," for CIE's performances at the Festival d'Automne. Obtained from the personal archive of Phil Edelstein.

CIE, 1977a. Program notes for performances at The Kitchen, New York City, January 6-8. Obtained from the personal archive of Phil Edelstein.

CIE, 1977b. CIE application to National Endowment for the Arts, seeking funding for rotating loudspeaker project. Los Angeles: Getty Research Institute, David Tudor Papers, acquisition no. 980039, box 3 folder 30.

CIE, 1978. Program notes for performances at The Kitchen, New York City, September 20-23. Obtained from the personal archive of Phil Edelstein.

CIE, 1979. Promotional package including one-page description of the group and brief biographies for Bill Viola, Ralph Jones, Philip Edelstein, Martin Kalve, Linda Fisher, Paul DeMarinis, John Driscoll, and David Tudor. Obtained from the personal archive of Phil Edelstein.

CIE, 1980a. Promotional package including one-page description of the group and biographies for Bill Viola, Ralph Jones, Philip Edelstein, Martin Kalve, John Driscoll, and David Tudor. Obtained from the personal archive of John Driscoll.

CIE, 1980b. Programme notes for performances by Ralph Jones, John Driscoll and Phil Edelstein at Ars Electronica festival, Sept 11-13. Obtained from the personal archive of John Driscoll.

CIE, 1982. Programme notes in English for performances by CIE at the Holland Festival, June 4-13. Obtained from the personal archive of Phil Edelstein.

CIE, 1996. *Rainforest V* Proposal to Thundergulch Consortium 11/1/96. Obtained from the personal archive of John Driscoll.

CIE, 1998. Programme book for *Rainforest IV*, Lincoln Center Festival, New York City, July 15-19. From the personal archive of the author.

COHEN, A.B., 1960. The "Bi-Phonic Coupler": A unique hi-fi speaker system. *Electronics World*, May 1960, 48-49.

COVELL, G.C., 2003. *David Tudor, Performer and Composer of Live Electronic Music: A Survey of Available Recordings* [online]. La Folia Online Music Review. Available from: <http://www.lafolia.com/archive/covell/covell200304tudor.html>

CRANE SCHOOL OF MUSIC, 1976. Programme for performance of *Rainforest*, February 4, at the Crane School of Music, State University

College, Potsdam NY. Obtained from the personal archive of Linda Fisher.

CROSS, L., 1966. The Video Images for David Tudor's *Bandoneon !*. Included with Experiments in Art and Technology archival material obtained from the personal archive of Anthony Gnazzo.

CROSS, L., 2001. *Remembering David Tudor: A 75th Anniversary Memoir* [online]. Available from: <http://www.lowellcross.com/articles/tudor/>

CROSS, L., 2004. Email to the author on December 2.

CUNNINGHAM DANCE FOUNDATION, 1968. Contract for Merce Cunningham Dance Company performances of *RainForest*, circa 1968. Los Angeles: David Tudor Papers, Getty Research Institute, acquisition no. 980039, box 29 folder 9.

CUNNINGHAM DANCE FOUNDATION, 1969a. Contract for commission of music for the dance *RainForest*, between Merce Cunningham Dance Company and David Tudor. Los Angeles: David Tudor Papers, Getty Research Institute, acquisition no. 980039, box 16 folder 10.

CUNNINGHAM DANCE FOUNDATION, 1969b. List of Musical Repertory Equipment as of August 24, 1969. Los Angeles: David Tudor Papers, Getty Research Institute, acquisition no. 980039, box 29 folder 10.

CUNNINGHAM, M., 1991. *The Dancer and the Dance: Merce Cunningham in conversation with Jacqueline Lesschaeve*. London: Marion Boyars.

David Tudor Instrument Collection, World Instrument Collection, Wesleyan University Music Department. Middletown, CT.

DELIO, T., 1984. *Circumscribing the Open Universe*. New York: University Press of America.

DEMARINIS, P., undated. *Description of Pygmy Gamelan* [online]. Available from: <http://www.well.com/~demarini/exhibitions.htm>

DEMARINIS, P., 1973. *Notes and circuit diagram for Pygmy Gamelan* [online]. Available from: http://www.globalpostmark.net/OrganicLogic/OrganicLogicTerrane/Organic_Logic_NO/pauldemarinas.html

DEMARINIS, P., 1980. Notes for *Forest Booties*. Seven-inch record. Lovely Music. VR-102.

DEMARINIS, P., 2001. Interview with the author, May 23, Stanford CA. [Recording in possession of author]

- DEMPSTER, S., 1999. Working with David Tudor and the Merce Cunningham Dance Company. *MusicWorks*, 73 (Spring), 14-19.
- DÖRSTEL, W., 1993. Chronologie. In: *Intermedial, Kontrovers, Experimentell: Das Atelier Mary Bauermeister in Köln 1960-62*. Cologne: Emons Verlag, 48.
- DRISCOLL, J., 1973. Letter to Julie Schwartz and post-Chocorua xerox mail network, ca. mid-September. Obtained from the personal archive of Phil Edelstein.
- DRISCOLL, J., 1975. Letter to Austin Clarkson on Pnumbral Raincoast letterhead regarding organisation of *Rainforest 4* performance at York University, Toronto, dated January 24 1975. Los Angeles: David Tudor Papers, Getty Research Institute, acquisition no. 980039, box 19 folder 7.
- DRISCOLL, J., 1976. Performance notes for John Cage's *Cartridge Music*, prepared for CIE performance at the Festival d'Automne. Obtained from the personal archive of John Driscoll.
- DRISCOLL, J., 1977. Centre for Music Experiment: Residency Report, dated February 15. Obtained from the personal archive of John Driscoll.
- DRISCOLL, J., 1978. Score diagram and notes for *Ebers and Mole - Interfeed* as performed at The Kitchen, September 20 1978. Obtained from the personal archive of John Driscoll.
- DRISCOLL, J., 1997. Electronics & Cooking (In memoriam David Tudor). *MusikTexte*, 69/70 (April), 78-79.
- DRISCOLL, J., 1998. Email to the author on July 29.
- DRISCOLL, J., 2000a. Personal communication with the author in May.
- DRISCOLL, J., 2000b. Telephone interview with the author on May 20. [Recording in possession of author]
- DRISCOLL, J., 2001a. Conversation with the author, Ralph Jones and John DS Adams, May 16, Valencia CA. [Notes in possession of author]
- DRISCOLL, J., 2001b. Conversation with the author, March 4, Port Washington NY. [Notes in possession of author]
- DRISCOLL, J., 2002. Interview with the author, May 20, Port Washington NY. [Recording in possession of author]
- DRISCOLL, J. 2005a. Email to the author on June 13.
- DRISCOLL, J. 2005b. Email to the author on December 12.

- DRISCOLL, J. 2005c. Email to the author on May 8.
- DRISCOLL, J. 2006a. Email to the author on January 8.
- DRISCOLL, J. 2006b. Email to the author on February 20.
- DRISCOLL, J. AND ROGALSKY, M., 2004. David Tudor's *Rainforest: An Evolving Exploration of Resonance*. *Leonardo Music Journal*, 14, 25-30.
- DROBNICK, J. (ed.) 2004. *Aural Cultures*. Toronto: YYZ Books.
- DUNN, D., 1996. A history of electronic music pioneers. In: KOSTELANETZ, R., ed., *Classic Essays on 20th Century Music*. New York: Schirmer Books, 21-62.
- EDELSTEIN, P., 1975. Letter to Jan Williams, September 2. Obtained from the personal archive of Phil Edelstein.
- EDELSTEIN, P., 1976a. Two sets of performance notes for John Cage's *Cartridge Music*, prepared for CIE performance at Festival d'Automne. Obtained from the personal archive of Phil Edelstein.
- EDELSTEIN, P., 1976b. Notes on equipment needed for CIE performances at Festival d'Automne. Obtained from the personal archive of Phil Edelstein.
- EDELSTEIN, P., 1976c. Three-page list of preferred loudspeaker objects and dimensions, per performer, for the Festival d'Automne. Obtained from the personal archive of Phil Edelstein.
- EDELSTEIN, P., 1980. Curriculum vitae. Obtained from the personal archive of Phil Edelstein.
- EDELSTEIN, P., 1996. Notes on David Tudor and *Rainforest*. From the personal archive of Phil Edelstein.
- EDELSTEIN, P., 2001. *Rainforest Diary*, Invermere, British Columbia, March 17, 2001. Personal notes on *Rainforest's* history and future, obtained from the personal archive of Phil Edelstein.
- EDELSTEIN, P., 2002. Interview with the author on May 12, Port Washington NY. [Recording in possession of author]
- EDELSTEIN, P., 2005a. Email to the author on July 18.
- EDELSTEIN, P., 2005b. Email to the author on August 4.
- EDELSTEIN, P., 2005c. Email to the author on December 17.
- EDELSTEIN, P., 2005d. Email to the author on December 18.

EDELSTEIN, P., 2005e. Email to the author on May 8.

EDELSTEIN, P., 2005f. Email to the author on May 10.

EDELSTEIN, P., 2005g. Email to the author on May 19.

EDELSTEIN, P., 2006a. Email to the author on January 7.

EDELSTEIN, P., 2006b. Email to the author on January 21.

EDELSTEIN, P., 2006c. Email to the author on January 24.

ELECTRONIC BODY ARTS, 1979. *The Development of a Video Art Facility by Electronic Body Arts, Inc.* [online]. Available from: <http://www.experimentalvcenter.org/history/groups/gtext.php3?id=31>

EMMONS, B., 2002. Interview with the author on May 10. New York. [Recording in possession of author]

EVERSON MUSEUM, 1974. Programme for performance of Rainforest at the Everson Museum, Syracuse NY, on March 8 1974. From the personal archive of Linda Fisher.

E.A.T., UNDATED. 9 Evenings: Theatre and Engineering: Variations VII by John Cage, October 15 and 16 1966: Documentary material on the performance assembled by E.A.T. Berkeley Heights: Experiments in Art and Technology.

E.A.T., UNDATED B. Live Programming for the Pepsi Pavilion. Los Angeles: David Tudor Papers, Getty Research Library, acquisition no. 980039, box 17 folder 6.

E.A.T., 1966. *9 Evenings of Theatre and Engineering* [programme book]. New York: Experiments in Art and Technology.

E.A.T., 1969. Live Programming for the Pepsi Pavilion: Request for Proposals, October 15 1969. In B. KLÜVER, J. MARTIN and B. ROSE, 1972 (eds.). *Pavilion*. New York: E.P. Dutton, 272-284.

E.A.T., 1970. "Projects Outside Art" poster. Obtained from Julie Martin of Experiments in Art and Technology.

E.A.T., 1972. *Pavilion*. B. KLÜVER, J. MARTIN and B. ROSE, eds. New York: E.P. Dutton.

E.A.T., 1977. Technical Log of *Island Eye Island Ear* Experiment on Knavelskar Island, Sweden, July 1974, edited December 13 1977. New York: Experiments in Art and Technology.

FISHER, L., 1973. Letter to David Tudor, July 16. Los Angeles: David Tudor Papers, Getty Research Institute, acquisition no. 980039, box 53, folder 10.

FISHER, L., 1974a. Letter to David Tudor, undated. Los Angeles: David Tudor Papers, Getty Research Institute, acquisition no. 980039, box 53, folder 10.

FISHER, L., 1974b. Letter to David Tudor, dated December 11. Los Angeles: David Tudor Papers, Getty Research Institute, acquisition no. 980039, box 53, folder 10.

FISHER, L., 1975a. Letter to David Tudor, dated only as "8/20" but established as 1975 per reference to upcoming Los Angeles County Museum performance. Los Angeles: David Tudor Papers, Getty Research Institute, acquisition no. 980039, box 53, folder 10.

FISHER, L., 1975b. Letter to David Tudor, undated but probably March/April 1975 per reference to upcoming performance dates in Buffalo. Los Angeles: David Tudor Papers, Getty Research Institute, acquisition no. 980039, box 53, folder 10.

FISHER, L., 1976a. Letter to David Tudor, dated March 21. Los Angeles: David Tudor Papers, Getty Research Institute, acquisition no. 980039, box 53, folder 10.

FISHER, L., 1976b. Letter to Phil Edelstein, dated August 17. Obtained from the personal archive of Phil Edelstein.

FISHER, L., 1979. Letter to David Tudor, dated August 18. Los Angeles: David Tudor Papers, Getty Research Institute, acquisition no. 980039, box 53, folder 10.

FISHER, L., 1980. Letter to David Tudor, dated May 17. Los Angeles: David Tudor Papers, Getty Research Institute, acquisition no. 980039, box 53, folder 10.

FISHER, L., 1998. Email to the author on July 23.

FISHER, L., 2003. Interview with the author on February 20, Ithaca, NY. [Recording in possession of author]

FISHER, L., 2004. Email to the author on February 24.

FLYNT, H., 1996. La Monte Young In New York, 1960-62. *In: W. DUCKWORTH and R. FLEMING, eds. Sound and Light: La Monte Young and Marian Zazeela.* Lewisburg: Bucknell University Press, 44-97.

FREHLING, R., 2002. Interview with the author on May 20, New York, NY. [Recording in possession of author]

FRÉTARD, Dominique, 2001. Bénédicte Pesle, ambassadrice et convertie de la première heure. *Le Monde*, 9 Nov. 2001 [online edition].

FURLONG, W., 1994. *Audio Arts: Discourse and Practice in Contemporary Art*. London: Academy Editions.

GANN, K., 1996. The Outer Edge of Consonance. In: W. DUCKWORTH and R. FLEMING, eds. *Sound and Light: La Monte Young and Marian Zazeela*. Lewisburg: Bucknell University Press, 152-190.

GARMIRE, E., 1972. An Overview. In: B. KLÜVER, J. MARTIN AND B. ROSE, eds. *Pavilion*. New York: E.P. Dutton & Co., 173-206.

GNAZZO, A., 2001. Interview with the author on May 25, Oakland, CA. [Recording in possession of author]

GRAY, D.P., 1997. The Art of the Impossible. *MusicWorks*, 69 (December), 18-21.

GRAY, D.P., 1998a. Email to the author July 24.

GRAY, D.P., 1998b. Email to the author December 1.

GRAY, D.P., 2002. *Biography of D'Arcy Philip Gray* [online]. Available from: <http://www.emf.org/tudor/About/gray.html>

GRAY, D.P., 2004. David Tudor in the Late 1980s: Understanding a Secret Voice. *Leonardo Music Journal*, 14, 41-48.

GRAY, D.P., 2005. Email to the author June 24.

GRELE, R.J., 1998. Movement without aim: methodological and theoretical problems in oral history. In: R. PERKS AND A. THOMSON, eds. *The Oral History Reader*. New York: Routledge, 38-52.

HARMONIC, P., 1973. Postcard to Julie Schwartz postmarked September 20, distributed on xerox mailing list, post-New Music in New Hampshire. Obtained from personal archive of Phil Edelstein.

HENRI, A. (ed.) 1974. *Environments and Happenings*. London: Thames and Hudson.

HERBERT F. JOHNSON MUSEUM OF ART, 1983. Programme for "An Evening of New Music" concert by John Driscoll and Linda Fisher, November 5. Obtained from the personal archive of John Driscoll.

HINES, T., 1994. Then Not Yet 'Cage': The Los Angeles Years, 1912-1938. In: M. PERLOFF AND C. JUNKERMAN, eds. *John Cage: Composed in America*. Chicago: University of Chicago, 65-99.

- HOLMES, T., 2002. *Electronic and Experimental Music*. New York: Routledge.
- HOLZAEPFEL, J., 1994. *David Tudor and the Performance of American Experimental Music, 1950-1959*. Thesis (PhD). City University of New York.
- HOLZAEPFEL, J., 2002. Cage and Tudor. In: NICHOLLS, D. (ed.) 2002. *The Cambridge Companion to John Cage*. Cambridge: Cambridge University Press, 169-185.
- HULTBERG, T., 1988. 'I Smile When the Sound is Singing Through Space': An Interview With David Tudor by Teddy Hultberg in Dusseldorf May 17, 18 1988 [online]. Electronic Music Foundation. Available from: <http://www.emf.org/tudor/Articles/hultberg.html>
- JENKS, A., 2001. Interview with the author, May 25, Oakland CA. [Recording in possession of author]
- JOHNSON, M., 1971. Letter from Mimi Johnson to Antoinette Vischer, dated November 1. JCDT Basel May 1972 folder. New York: Performing Artservices papers, John Cage Trust.
- JOHNSON, M., 2003. Email to the author.
- JOHNSON, M., 2005. Email to the author on December 26.
- JOHNSON, T., 1973. It's so bleep-ful in the country. *New York Times*, July 22 1973, 97.
- JOHNSON, T., 1975. New Music column. *High Fidelity and Musical America*, August, MA12-13.
- JOHNSON, T., 2002. *The Voice of New Music*. Paris: Editions 75.
- JONES, R., 1973a. Letter to Julie Schwartz and post-Chocorua xerox mail network, dated September 3. Obtained from the personal archive of Phil Edelstein.
- JONES, R., 1973b. Letter to David Tudor, dated July 17. Los Angeles: David Tudor Papers, Getty Research Institute, acquisition no. 980039, box 54 folder 6.
- JONES, R., 1980. Folio of promotional materials for Ralph Jones including reviews, interview excerpts and descriptions and diagrams of *Star Networks at the Singing Point* and *Dry Pool Soundings*. Obtained from the personal archive of John Driscoll.
- JONES, R., 1998. Email to the author on June 30.

- JONES, R., 2001. Interview with the author on May 25, Fairfax, CA. [Recording in possession of author]
- JONES, R., 2003. Email to the author on July 15 2005.
- JONES, R., 2004. Composer's Notebook: *Star Networks at the Singing Point*. *Leonardo Music Journal*, 14, 81-82.
- JONES, R., 2005a. Email to the author on May 15.
- JONES, R., 2005b. Email to the author on May 18.
- JONES, R., 2006a. Email to the author on January 25.
- JONES, R., 2006b. Email to the author on February 20.
- KAHN, D., 1999. *Noise Water Meat: A History of Sound in the Arts*. Cambridge: MIT Press.
- KAHN, D., 2001. 'Something more than interesting': David Tudor and the sound of Anthroposophy. Paper presented at symposium The Art of David Tudor: Indeterminacy and Performance in Postwar Culture, Getty Research Intitute, Los Angeles, May 17-19.
- KALLMAN, H., WOOG, A.P. AND WESTERKAMP, H., 1992. *World Soundscape Project* [online]. The Encyclopedia of Music in Canada. Available from: <http://www.collectionscanada.ca/emc>.
- KALVE, M., 1973. Form letter to Chocorua '73 alumni, establishing Pnumbral Raincoast round-robin mail network, November 19. Copy of form letter received by David Tudor obtained from the personal archive of Phil Edelstein.
- KALVE, M., 1974. Curriculum vitae. Obtained from the personal archive of Phil Edelstein.
- KALVE, M., 1977. Draft of letter to August Jaccaci of Lawrence Academy, Groton MA, January 14. Los Angeles: David Tudor Papers, Getty Research Institute, acquisition no. 980039, box 20 folder 4.
- KALVE, M., 1978. Score diagram for *Earthing*. Obtained from the personal archive of John Driscoll.
- KALVE, M., 2003. Telephone interview with the author on December 26. [Recording in possession of author]
- KIERONSKI, R., UNDATED. The Vochrome. Article included with Experiments in Art and Technology archival material from the personal archive of Anthony Gnazzo.

KLOSTY, J. (ed.) 1975. *Merce Cunningham*. New York: E.P. Dutton and Co.

KLÜVER, B., 1970. Rainforest position statement for Experiments in Art and Technology, dated January 30. Los Angeles: E.A.T. Papers, Getty Research Institute, acquisition no. 940003, box 120 folder 26.

KLÜVER, B., MARTIN, J. AND ROSE, B. (eds), 1972. *Pavilion*. New York: E.P. Dutton & Co.

KLÜVER, B., 1979. Interview with Billy Klüver in "Island Eye Island Ear proposal May 25 1979 for Boulder Island (Saranac Lake, Adirondacks)". Los Angeles: Tudor Papers, Getty Research Institute, acquisition no. 980039, box 21 folder 9.

KLÜVER, B., 2002. Interview with the author on May 8. Berkeley Heights, NJ. [Recording in possession of author]

KLÜVER, B., 2004. Interview. *In: 9 Evenings: Theatre and Engineering*. Directed by Barbro Schultz LUNDESTAM. Experiments in Art and Technology.

KOSTELANETZ, R. (ed.) 1992. *Merce Cunningham: Dancing in Space and Time*. London: Dance Books Inc.

KOTIK, P., 1973. Letter to the program committee of New Music in New Hampshire, Inc., dated September 5 1973. Obtained from the personal archive of Phil Edelstein.

KOTIK, P., 2005a. Email to the author on June 27.

KOTIK, P., 2005b. Telephone interview with the author on June 28. [Recording in possession of author]

KOTIK, P., 2005c. Email to the author on June 23.

KRAMER, G., 2005a. Email to the author on 26 July.

KRAMER, G., 2005b. Email to the author on 27 July.

KUIVILA, R.J., 2004. Open Sources: Words, Circuits and the Notation-Realization Relation in the Music of David Tudor. *Leonardo Music Journal*, 14, 17-23.

KUIVILA, R.J., 2005. Email to the author on May 16.

KURTZ, M., 1992. *Stockhausen: A Biography*. London: Faber and Faber.

LA BARBARA, J., 1979. New Music column. *High Fidelity and Musical America*, January, MA10.

LA BARBARA, J., 2005. Email to the author on August 7.

LECAINE, H., 1968. Letter to John Cage, August 20. Evanston: John Cage Correspondence Collection, Northwestern University Library, item C41A.35.

LEONARDINI J.-P., COLLIN, M. AND MARKOVITS, J., 1982. Festival d'Automne à Paris 1972-1982. Paris: Editions Messidor / Temps Actuels, 1982.

LINDGREN, N., 1972. Into the Collaboration. *In*: B. KLÜVER, J. MARTIN AND B. ROSE, eds. *Pavilion*. New York: E.P. Dutton & Co., 3-59.

LUCIER, A., 1995. *Reflections: Interviews, Scores, Writings*. Cologne: MusikTexte.

MATSUSHITA ELECTRICAL INDUSTRIAL CO., 1996. *The Official Record of Time Capsule Expo '70* [online]. Available from: http://park.org/Japan/Panasonic/time_capsule/record/00.html.

MCDONAGH, D., 1992. Merce Cunningham. *In*: R. KOSTELANETZ, ED. *Dancing in Space and Time*. London: Dance Books, 1-14.

MCGARRAH, B., 2005. Email to the author on June 6.

MECÁNICA POPULAR, 1966. Construya el fantastico altoparlante sin cono! *Mecánica Popular*, September 1966, 33-34. Found in: Los Angeles: Getty Research Institute, David Tudor Papers, acquisition no. 980039, box 37 folder 6.

MEDIA STUDY / BUFFALO, 1978. Photocopied notice for CIE lecture-demonstration series "Aspects of Collaboration in Electronic Performance" at Media Study / Buffalo, November 12-December 3. Los Angeles: Getty Research Institute, David Tudor Papers, acquisition no. 980039, box 20 folder 12.

MEDIA STUDY / BUFFALO, 1979. *Media Study / Buffalo newsletter January 1979* [online]. Archive of Woody and Steina Vasulka. Available from: [http://www.vasulka.org/archive/4-30d/MedBufJan79\(6000\).pdf](http://www.vasulka.org/archive/4-30d/MedBufJan79(6000).pdf)

MEYER, A.P., 2001. *Le Pavilion Philips & Le Poeme Electronique* [online]. Eindhoven, Media Interaction Philips Research. Available from: <http://home.hccnet.nl/a.meyer/philipspavilion58/index.html>

MILLER, G., 1974. Music 'Molded' at Museum. Review of *Rainforest* performance in *Syracuse Herald Journal*, March 9 1973, 10.

MUMMA, G., 1970. Memo to John Cage and David Tudor circa 1970. Los Angeles: David Tudor Papers, Getty Research Institute, acquisition no. 980039, box 54 folder 3.

MUMMA, G., 1972. A Brief Introduction to the Sound-Modifier Console. *In: B. KLÜVER, J. MARTIN AND B. ROSE, eds. Pavilion.* New York: E.P. Dutton & Co., 238-242.

MUMMA, G., 1973. Letter to the board of directors of New Music in New Hampshire, Inc., August 5 1973. Obtained from the personal archive of Phil Edelstein.

MUMMA, G., 1973b. Letter to the board of directors of New Music in New Hampshire, Inc., August 20 1973. Obtained from the personal archive of Phil Edelstein.

MUMMA, G., 1975. From Where the Circus Went. *In: J. KLOSTY, ED. Merce Cunningham.* New York: Saturday Review / EP Dutton & Co., 65-73.

MUMMA, G., 2001a. Email to the author on March 14.

MUMMA, G., 2001b. Email to the author on April 17.

MUMMA, G., 2001c. Email to the author on April 18.

MUMMA, G., 2001d. Email to the author on April 19.

MUMMA, G., 2001e. Interview with the author on May 22. Orinda, CA. [Recording in possession of author]

MUMMA, G., 2001f. Email to the author on March 16.

MUMMA, G., 2005a. Email to the author on June 21.

MUMMA, G., 2005b. Email to the author on June 28.

MUMMA, G., 2006a. Email to the author on April 4.

MUMMA, G., 2006b. Email to the author on September 13.

MUSÉE D'ART CONTEMPORAIN DE MONTRÉAL., 1996. *Bill Viola works list* [online]. Available from: http://media.macm.org/biobiblio/viola_b/2violaoeuvres.htm.

MYERS, H., 1992. Fieldwork. *In H. MYERS, ed., Ethnomusicology: An Introduction.* New York: W.W. Norton.

NEW MUSIC IN NEW HAMPSHIRE, 1973a. Registration package for prospective students. Obtained from the personal archive of Gordon Mumma.

NEW MUSIC IN NEW HAMPSHIRE, 1973b. Registration confirmation letter, course schedule and notes for students. Obtained from the personal archive of Phil Edelstein.

NEW MUSIC IN NEW HAMPSHIRE, 1973c. Report of Chocorua '73 by Petr Kotik, Founder and Artistic Director. Obtained from the personal archive of Petr Kotik.

NEUHAUS, M., 1967. *Performer's Notes for Fontana Mix-Feed* [online]. *Aspen Magazine*, 5/6, item 21. Available from: <http://www.ubu.com/aspen/aspen5and6>. Originally published New York: Roaring Fork Press, Fall/Winter 1967.

NIBLOCK, P., 2000. Telephone interview with the author on May 20. [Recording in possession of author]

NICHOLLS, D. (ed.) 2002. *The Cambridge Companion to John Cage*. Cambridge: Cambridge University Press.

NORDIN, I.L., UNDATED. *Stockhausen CD Edition no. 9 (Mikrophonie I & II/Telemusik)* [online]. Sonoloco Record Reviews, Ingvar Loco Nordin's Webpage. Available from: <http://home.swipnet.se/sonoloco2/Rec/Stockhausen/09.html>

NYMAN, M., 1999. *Experimental Music: Cage and Beyond*. Cambridge: Cambridge University Press.

OLIVEROS, P., 2003. Email to the author on November 3.

Osaka World Exposition 1970: Automobile Pavilion [online]. Department of Architecture, National University of Singapore. Available from: <http://www.arch.nus.edu.sg/expo/pavilions/automobile/automobile.html>

Osaka World Exposition 1970: Fuji Group Pavilion [online]. Department of Architecture, National University of Singapore. Available from: <http://www.arch.nus.edu.sg/expo/pavilions/fuji/fuji.html>

Osaka World Exposition 1970: German Pavilion [online]. Department of Architecture, National University of Singapore. Available from: <http://www.arch.nus.edu.sg/expo/pavilions/german/german.html>

Osaka World Exposition 1970: Pavilion Index [online]. Department of Architecture, National University of Singapore. Available from: <http://www.arch.nus.edu.sg/expo/pavilions/pavilionsindex.html>

Osaka World Exposition 1970: Swiss Pavilion [online]. Department of Architecture, National University of Singapore. Available from <http://www.arch.nus.edu.sg/expo/pavilions/swiss/swiss.html>

Osaka World Exposition 1970: Takara Beutilion [online]. Department of Architecture, National University of Singapore. Available from: <http://www.arch.nus.edu.sg/expo/pavilions/takara/takara.html>

OTTE, H., 1971. Otte-Cage correspondence, 1 Feb 1971. New York: Performing Artservices papers, John Cage Trust.

PAIK, N.J., 1997. Untitled [notes on David Tudor]. *Music*, 1, 24-25.

PATTERSON, D., 1997. Celebrating a Life. *MusicWorks*, 67 (Spring), 57-58.

PEARCE, J., 1972. An Architect's View. In: B. KLÜVER, J. MARTIN AND B. ROSE, eds. *Pavilion*. New York: E.P. Dutton & Co., 255-265.

PERFORMING ARTSERVICES, INC., 1976a. Draft cargo and insurance manifest, October 6, for shipping of CIE equipment to Paris for Festival d'Automne. Obtained from the personal archive of Phil Edelstein.

PERFORMING ARTSERVICES, INC., 1976b. Letter from Marsha Green of Artservices, to Phil Edelstein, dated July 29. Obtained from the personal archive of Phil Edelstein.

PERFORMING ARTSERVICES, INC., 1976c. Letter from Marsha Green of Artservices, to members of CIE, dated September 17. Obtained from the personal archive of Phil Edelstein.

PERFORMING ARTSERVICES, INC., 1980. Letter from Jean Rigg to Barbara Mayfield of Artservices, regarding contract details for *Rainforest 4 LP*. Los Angeles: David Tudor Papers, Getty Research Institute, acquisition no. 980039, box 25 folder 6.

PERLIS, V., 1994. Oral History and Music. *The Journal of American History*, 81:2, 610-619.

PERLOFF, N., 2004. Hearing Spaces: David Tudor's Collaboration on *Sea Tails*. *Leonardo Music Journal*, 14, 31-39.

POOLE, P., 2001. Telephone interview with the author on April 15. [Recording in possession of author]

POPULAR MECHANICS, 1965. Fantastic coneless loudspeaker! *Popular Mechanics*, December 1965, 100-101. Copy found in: Los Angeles: David Tudor Papers, Getty Research Institute, acquisition no. 980039, box 46, folder 9.

POPULAR MECHANICS, 1966. Build a fantastic coneless loudspeaker! *Popular Mechanics*, June 1966, 168-170. Copy found in: Los Angeles: David Tudor Papers, Getty Research Institute, acquisition no. 980039, box 46, folder 9.

POTTER, K., 2000. *Four Musical Minimalists*. Cambridge: Cambridge University Press.

PRITCHETT, J., 1993. *The Music of John Cage*. Cambridge: Cambridge University Press.

PRITCHETT, J., 2000. *David Tudor's realization of John Cage's Variations II* [online]. Princeton, Department of Music, Princeton University. Available from:
<http://www.music.princeton.edu/~jwp/texts/Var2.html>

PRITCHETT, J., 2004. David Tudor as Composer/Performer in Cage's *Variations II*. *Leonardo Music Journal*, 14, 11-16.

Proposals for live programming. In: B. KLÜVER, J. MARTIN AND B. ROSE, eds. *Pavilion*. New York: E.P. Dutton & Co., 285-320.

Rainforest, 1968. Film. Directed by D.A. PENNEBAKER AND R. LEACOCK, R. New York: Pennebaker Hegedus Films.

REVILL, D., 1992. *The Roaring Silence: John Cage: A Life*. London: Bloomsbury.

RICHARDS, M.C., 1959. Letter from MC Richards. Los Angeles: David Tudor Papers, Getty Research Institute, acquisition no. 980039, box 58 folder 9.

RICHARDS, M.C., 1997. Ecstatic Experience: Memories of David Tudor. *MusikTexte*, 69/70 (April), 65-66.

RIGG, J., 1970. Letter to David Tudor 11 March 1970. Los Angeles: David Tudor Papers, Getty Research Institute, acquisition no. 980039, box 58 folder 11.

RIGG, J., 2002. Interview with the author on May 17 2002. New York City. [Recording in possession of author]

ROGALSKY, M., 1995. "...in rehearsals, or preparation, or setup, or from one performance to another." — *Live Electronic Music and Musicians of the Merce Cunningham Dance Company*. MA thesis, Wesleyan University.

ROGALSKY, M., 1999. David Tudor's *Virtual Focus*. *MusicWorks*, 73 (Spring), 20-23.

ROGALSKY, M., 2001. Notes from dinner conversation May 16 with John Driscoll, Ralph Jones and John D.S. Adams. [Notebook in possession of author]

ROGALSKY, M., 2002. David Tudor's *Untitled: Feeding Forward*. *Resonance*, 9 (2), 8-10.

ROGALSKY, M. AND DRISCOLL, J., 2004. David Tudor's *Rainforest: An Evolving Exploration of Resonance*. *Leonardo Music Journal*, 14, 25-30.

SAKURAMOTO, Y., 1997. *Untitled* [biographical notes on David Tudor]. *Music*, 1, 22-23.

SAKURAMOTO, Y., 2001. For Our Further Adventures of Hearing. Published online at: <http://www.aac.pref.aichi.jp/english/aac/aac32-e/aac32-7-2.html>.

SANDIFUR, A., 1973. New Music in New Hampshire. *EAT*, issue 6, published by Music West, Charles Shere, ed, 1824 Curtis Street, Berkeley, CA 94702. Photocopy of article obtained from personal archive of Phil Edelstein.

SCHWARTZ, J., 1973a. Letter to Chocorua '73 participants, dated August 29. Obtained from personal archive of Phil Edelstein.

SCHWARTZ, J., 1973b. Letter to programming committee of New Music in New Hampshire, Inc., ca. September-October. Obtained from personal archive of Phil Edelstein.

SIMON, D., 1990. Alvin Lucier in Conversation with Douglas Simon. *In: D. LANDER AND MICAH LEXIER, eds. Sound By Artists*. Toronto: Art Metropole and Walter Phillips Gallery, 193-198.

SLOBIN, M. AND SHEFF, R., 1966. Music Beyond the Boundaries. *Generation: The inter-arts magazine*, 17 (2), 83-84.

SMOLIAR, S., 1992. Merce Cunningham in Brooklyn. *In: R. KOSTELANETZ, ED. Dancing in Space and Time*. London: Dance Books, 77-91.

STEDELIIK MUSEUM, 1982. *'60-'80: Attitudes, Concepts, Ideas: A selection from twenty years of visual arts*. Amsterdam: Stedelijk Museum / Van Gennep.

STEINER, R., 1904. *Knowledge of the Higher Worlds and its Attainment* [online]. Rudolph Steiner Archive. Available from: http://wn.rsarchive.org/Books/GA010/English/GA010_index.html

STEINER, R., 1906. *The Inner Nature of Music and the Experience of Tone* [online]. Rudolph Steiner Archive. Available from: <http://wn.rsarchive.org/Lectures/InNatMusic>.

STOCKHAUSEN, K. *About the Piano Pieces* [online]. Kurten, Germany, Stockhausen-Verlag. Available from: http://www.stockhausen.org/intro_piano_pieces.html

SUGGS, D.N. AND SIMMONS, A.M., 2005. Information theory analysis of patterns of modulation in the advertisement call of the male bullfrog, *Rana Catesbeiana*. *Journal of the Acoustical Society of America*, 117, 2330-2337.

SUNDELL, N., 1984. *Rauschenberg/Performance*. Cleveland: Cleveland Center for Contemporary Art.

SUTHERLAND, R., 1994. *New Perspectives in Music*. London: Sun Tavern Fields.

Takehisa Kosugi [online]. Lovely Music. Available from: <http://www.lovely.com/bios/kosugi.html>

The Bi-Phonic Coupler. *Electronics World*, May 1960. Found in David Tudor Papers, Getty Research Institute, acquisition no. 980039, box 37 folder 4.

THOMPSON, E., 2002. *The Soundscape of Modernity: Architectural Acoustics and the Culture of Listening in America, 1900-1933*. Cambridge: The MIT Press.

TOMKINS, C., 1976. *The Bride and the Bachelors*. New York: Penguin.

TUCHMAN, M., 1971. *Art & Technology: A report on the Art & Technology Program of the Los Angeles County Museum of Art 1969-1971*. New York: Viking Press.

TUDOR, D., UNDATED. Entries for items in three cases accompanying Tudor as checked baggage. Los Angeles: David Tudor Papers, Getty Research Library, acquisition no. 980039, box 30 folder 3.

TUDOR, D., UNDATED A. Handwritten notes in black notebook. Los Angeles: David Tudor Papers, Getty Research Institute, acquisition no. 980039, box 4 folder 19.

TUDOR, D., UNDATED B. Handwritten note. Los Angeles: David Tudor Papers, Getty Research Institute, acquisition no. 980039, box 16 folder 1.

TUDOR, D., UNDATED C. Tudor notebook. Los Angeles: David Tudor Papers, Getty Research Institute, acquisition no. 980039, box 4 folder 21.

TUDOR, D., 1966. Audio documentation of *Bandoneon !*. Obtained from the Estate of David Tudor.

TUDOR, D., 1966a. Notes on transducers and materials found alongside an unsigned contract dated July 22 1966. Los Angeles: David Tudor Papers, Getty Research Institute, acquisition no. 980039, box 16 folder 1.

TUDOR, D., 1966b. Programme notes for *Bandoneon ! In: 9 Evenings of Theatre and Engineering* programme book. Experiments in Art and Technology.

TUDOR, D., 1966c. Bandoneon Factorial Generalized Diagram. Los Angeles: David Tudor Papers, Getty Research Institute, acquisition no. 980039, box 1 folder 9.

TUDOR, D., 1966d. *Bandoneon !* work notes. Obtained from the Estate of David Tudor prior to deposit of Tudor papers with the Getty Research Institute.

TUDOR, D., 1966e. Draft of "pre- and post-operative note" for *Bandoneon !* Los Angeles: David Tudor Papers, Getty Research Institute, acquisition no. 980039, box 3 folder 2.

TUDOR, D., 1968. Option list for *Rainforest*. Obtained from the Estate of David Tudor in 1996, prior to deposit of Tudor papers with the Getty Research Institute.

TUDOR, D., 1968a. Block diagram for *Rainforest 1*. Copy obtained from Estate of David Tudor in 1996, prior to deposit of Tudor papers with the Getty Research Institute.

TUDOR, D., 1970. Diagram and notes for *Pepsibird*. Copy obtained from Estate of David Tudor in 1996, prior to deposit of Tudor papers with the Getty Research Institute.

TUDOR, D., 1970a. Diagram and notes for *Anima Pepsi*. Copy obtained from Estate of David Tudor in 1996, prior to deposit of Tudor papers with the Getty Research Institute.

TUDOR, D., 1970b. Notes for Pepsi Pavilion programming. Los Angeles: David Tudor Papers, Getty Research Institute, acquisition no. 980039, box 18 folder 2.

TUDOR, D., 1972. Draft of program notes for *Rainforest 3*. Los Angeles: David Tudor Papers, Getty Research Institute, acquisition no. 980039, box 4 folder 21.

TUDOR, D., 1972a. Draft program notes. Los Angeles, David Tudor Papers, Getty Research Institute, acquisition no. 980039, box 4 folder 21.

TUDOR, D., 1972b. From Piano to Electronics. *Music and Musicians*, 20, 24–26.

TUDOR, D., 1972c. List of technical requirements for performance of *Rainforest 3* and John Cage's *Mureau*. New York: Performing Artservices papers, John Cage Trust.

TUDOR, D., 1972d. Notes on modification of *Rainforest 3* and *Untitled*. Los Angeles: David Tudor Papers, Getty Research Institute, acquisition no. 980039, box 3 folder 28.

TUDOR, D., 1972e. Diagram of eight-channel speaker setup for performance of *Rainforest 3*, Berlin, July 11 1972. Los Angeles: David Tudor Papers, Getty Research Institute, acquisition no. 980039, box 3 folder 28.

TUDOR, D., 1972f. Notes on *Rainforest 3*. Los Angeles: David Tudor Papers, Getty Research Institute, acquisition no. 980039, box 4 folder 8.

TUDOR, D., 1972g. Score diagram sketches for *Rainforest 3*. Obtained from the Estate of David Tudor in 1996, prior to deposit of Tudor papers with the Getty Research Institute.

TUDOR, D., 1972h. "Master" score diagram for *Rainforest 3*. Los Angeles: David Tudor Papers, Getty Research Institute, acquisition no. 980039, box 3 folder 28.

TUDOR, D., 1973. Notes on teaching *Rainforest*. Los Angeles: David Tudor Papers, Getty Research Library, acquisition no. 980039, box 4 folder 19.

TUDOR, D., 1973a. Score diagram for *Rainforest 4*. Obtained from the Estate of David Tudor.

TUDOR, D., 1973b. Seven pages of notes and diagrams for realisation of *Sliding Pitches in the Rainforest in the Field* [*Rainforest 4*] at New Music New Hampshire, July 1973. Getty Research Library, acquisition no. 980039, box 40 folder 6.

TUDOR, D., 1973c. List of 19 loudspeaker-objects for realisation of *Sliding Pitches in the Rainforest in the Field* [*Rainforest 4*] at New Music New Hampshire, July 1973. Getty Research Library, acquisition no. 980039, box 210 folder 7.

TUDOR, D., 1973d. Two pages of notes for "still" and "sprinkler" loudspeaker-object source signals for *Sliding Pitches in the Rainforest in the Field* [*Rainforest 4*] at New Music New Hampshire, July 1973. Getty Research Library, acquisition no. 980039, box 37 folder 4.

TUDOR, D., 1973e. Class schedule and two copies of contract for teaching engagement at New Music New Hampshire, July 1973. Getty Research Library, acquisition no. 980039, box 18 folder 13.

TUDOR, D., 1974a. Letter to Jean Rigg. Los Angeles: David Tudor Papers, Getty Research Library, acquisition no. 980039, box 109 folder 18.

TUDOR, D., 1974b. Note circa 1974. Los Angeles: David Tudor Papers, Getty Research Institute, acquisition no. 980039, box 109 folder 18.

TUDOR, D., 1975. Letter to Suzanne Weil, Coordinator of Performing Arts, Walker Arts Centre, September 25. Minneapolis: Walker Arts Centre Archives.

TUDOR, D., 1976. Letter to Suzanne Weil, Coordinator of Performing Arts, Walker Arts Centre, April 28. Minneapolis: Walker Arts Centre Archives.

TUDOR, D., 1976a. Handwritten draft of introduction to programme book for Composers Inside Electronics concert series at the Festival d'Automne. Los Angeles: David Tudor Papers, Getty Research Institute, acquisition no. 980039, box 19 folder 12.

TUDOR, D., 1976b. Notes to CIE on the performance of John Cage's *Atlas Eclipticalis*. Obtained from the personal archive of John Driscoll.

TUDOR, D., 1976c. Note on differences between *Rainforest* and *Forest Speech*. Los Angeles: David Tudor Papers, Getty Research Institute, acquisition no. 980039, box 3 folder 15.

TUDOR, D., 1977. Score diagram for *Forest Speech*. Los Angeles: David Tudor Papers, Getty Research Institute, acquisition no. 980039, box 3 folder 15.

TUDOR, D., 1977b. Score diagram for *Forest Speech*, dated 3/20/77. Los Angeles: David Tudor Papers, Getty Research Institute, acquisition no. 980039, box 3 folder 15.

TUDOR, D., 1978. Score diagram for *Forest Speech* labeled "D. Tudor '78-'79". Obtained from the Estate of David Tudor.

TUDOR, D., 1978a. Draft of score diagram for *Forest Speech*. Obtained from the Estate of David Tudor.

TUDOR, D., 1997. Untitled [manuscript of "From Piano to Electronics" as published in Tudor, 1972b]. *Music*, 1, 27-29.

TUDOR, D., 1980. Liner notes to *Rainforest IV*. LP. Gramavision. GR-EB 1.

TUDOR, D., 1982. Merce Cunningham Dance Company equipment list from September 1982, handwritten by David Tudor. Los Angeles: David Tudor Papers, Getty Research Institute, acquisition no. 980039, box 25 folder 13.

TUDOR, D., 1984. *Interview with John David Fulleman, Stockholm, May 31* [online]. Available from: <http://www.emf.org/tudor/Articles/fullemann.html>

TUDOR, D., 1986. Interview with Bruce Duffie, Chicago, April 7. Recording obtained from the interviewer.

TUDOR, D., 1988. Draft of program notes for 1988 revival of the dance *RainForest 1*. Los Angeles: David Tudor Papers, Getty Research Institute, acquisition no. 980039, box 110 folder 15.

TUDOR, D., 1988a. *Interview with Teddy Hultberg, Dusseldorf, May 17-18* [online]. Available from: <http://www.emf.org/tudor/Articles/hultberg.html>

TUDOR, D., 1989. *Interview with Larry Austin, April 3 1989, Denton, Texas* [online]. Available from: <http://www.emf.org/tudor/Articles/austin.html>

TUDOR, D., 1993. *Interview with Joel Chadabe, September 8, Tomkins Cove NY* [online]. Available from: <http://www.emf.org/tudor/Articles/chadabe.html>

TUDOR, D., 1994. Interview with the author on November 2. Tomkins Cove, New York. [Recording in possession of author]

TUDOR, D., 1995. Interview with the author on March 28. Tomkins Cove, New York. [Recording in possession of author]

TUDOR, D., AND CAGE, J. 1985. Interview with Dick Witts at the Institute of Contemporary Arts, London. London: National Sound Archive.

VAUGHAN, D., 1997. *Merce Cunningham: Fifty Years*. New York: Aperture Foundation.

VIOLA, B., 1973. Letter to David Tudor, undated, postmarked July 30. Los Angeles: David Tudor Papers, Getty Research Library, acquisition no. 980039, box 60 folder 2.

VIOLA, B., 1974. Letter to David Tudor, undated but closely following performances of *Rainforest* in Syracuse on March 8 and 9 1974. Los Angeles: David Tudor Papers, Getty Research Library, acquisition no. 980039, box 60 folder 2.

VIOLA, B., 1974a. Letter to David Tudor, written on Long Beach Museum of Art letterhead, undated but likely ca. November-December 1974. Los Angeles: David Tudor Papers, Getty Research Library, acquisition no. 980039, box 60 folder 2.

VIOLA, B., 1977. Live performance recording of *Gong* at The Kitchen, New York City, January 8. Recording obtained from archives of The Kitchen.

VIOLA, B., 1986. Postcard to David Tudor. Los Angeles: David Tudor Papers, Getty Research Institute, acquisition no. 980039, box 60 folder 2.

VIOLA, B., 1995. *Reasons for Knocking at an Empty House*. London: Thames and Hudson.

VIOLA, B., 2000. Interview with the author on July 2. London, UK. [Recording in possession of author]

VIOLA, B., 2001. Discussions with the author May 19 at the Getty Museum, Los Angeles CA. [Notes in possession of author]

VIOLA, B., 2001a. Discussions with the author May 19 while driving between Getty Museum, Los Angeles CA, and California Institute of the Arts, Valencia CA. [Notes in possession of author]

VIOLA, B., 2004. David Tudor: The Delicate Art of Falling. *Leonardo Music Journal*, 14, 49-56.

WBFO, 1978. Interview with David Tudor, John Driscoll, Ralph Jones, and Martin Kalve of Composers Inside Electronics, "Plastic" [title of show] with host Mark Fruehauf, December 5. Recording of broadcast obtained from the personal archive of John Driscoll.

WALDHAUER, F., 1966. Proportional Control System. Article included with Experiments in Art and Technology archival material provided by Anthony Gnazzo.

WEIL, S., 1976. Letter to David Tudor, April 29. Minneapolis: Walker Arts Centre Archive.

WILSON, S., 2006. Email to the author on February 28.

WOLFF, C., 1996. Thinking of David Tudor. *MusikTexte*, 69/70 (April), 51-52.

WOLFF, C., 1998. *Cues: Writings and Conversations*. Köln: MusikTexte.

YOUNG, L.A. AND ZAZEELA, M., 1996. Continuous Sound and Light Environments. In: W. DUCKWORTH AND R. FLEMING, eds. *Sound and*

Light: La Monte Young and Marian Zazeela. Lewisburg: Bucknell University Press, 218-221.

YOUNG, L.A., 2000. Liner notes for *Drift Study 31 | 69 c. 12:17:33-12:49:58 PM NYC.* In: *Ohm: The Early Gurus of Electronic Music 1948-1980.* CD. Ellipsis Arts. CD3670.

ZVONAR, R., 2003. A History of Spatial Music. In: *Sound In Space.* Toronto: New Adventures in Sound Art.

LIST OF INTERVIEWS

Following is a list of formal interviews conducted by the author with colleagues and friends of David Tudor. Most of these also appear in the combined reference and bibliography list.

Amacher, Maryanne. May 22 2000, telephone interview.
von Biel, Michael. December 11 2001, telephone interview.
Brown, Carolyn. September 12 2002, London UK.
Burchfield, Ritty. February 27 2001, New York NY.
Burchfield, Ritty. May 10, 2002, New York NY.
DeMarinis, Paul. May 23 2001, Stanford CA.
Driscoll, John. May 20 2000, telephone interview.
Driscoll, John. March 4 2001, Port Washington NY.
Driscoll, John. May 11 2002, Port Washington NY.
Edelstein, Phil. March 4 2001, Port Washington NY.
Edelstein, Phil. May 13 2002, Port Washington NY.
Emmons, Beverly. May 10 2002, New York NY.
Fisher, Linda. February 20 2003, Ithaca NY.
Frehling, Russell. May 12 2002, New York NY.
Gnazzo, Anthony. May 25 2001, Oakland CA.
Jenks, Alden. May 25 2001, Oakland CA.
Jones, Ralph. May 25 2001, Fairfax CA.
Kalve, Martin. December 26 2004, telephone interview.
Klüver, Billy and Martin, Julie. May 8 2002, Berkeley Heights, NJ.
Kosugi, Takehisa. November 28 1996, Paris France.
Kotik, Petr. June 28 2005, telephone interview.
Manley, Ben. March 2 2006, telephone interview.
Mumma, Gordon. May 22 2001, Orinda CA.
Niblock, Phill. May 20 2000, telephone interview.
Poole, Peter. April 15 2001, telephone interview.
Rigg, Jean. May 17 2002, New York NY.
Monnier, Jacqueline Matisse. April 15 1996, Villiers-sous-Grez France.
Viola, Bill. July 2 2000, London UK.
Viola, Bill. May 19 2001, Los Angeles / Valencia CA.

DISCOGRAPHY

Annotated list of commercially released recordings

CAGE, J., 1972. *Mureau* [Reel-to-reel / cassette]. S-Press.

Currently available online at: http://www.ubu.com/sound/cage_mureau.html

CAGE, J., 1991. *Music for Merce Cunningham* [CD]. Mode Records 24.

Includes recording of *Cartridge Music* (1960) performed by David Tudor, Takehisa Kosugi, and Michael Pugliese.

CAGE, J. and TUDOR, D., 2000. *Rainforest II / Mureau* [CD]. New World Records 80540-2.

Version of *Rainforest* documented here is misidentified as *Rainforest 2*: should be *Rainforest 3*.

GIORNO POETRY SYSTEMS, 1975. *Biting the Tongue of a Corpse* [LP].
Giorno Poetry Systems (GPS-005).

Includes excerpt of John Cage reading *Mureau* at St. Marks Church, New York City, January 1, 1975. Currently available online at:
<http://www.ubu.com/sound/corpse.html>

IMAGINARY LANDSCAPES, 1989. Compilation of live performance excerpts from *The Kitchen*, New York City [CD]. Elektra Nonesuch 9 79235-2.

Includes excerpt from David Tudor performance of *Dialects* (1984).

TUDOR, D., 1975. *Microphone* [LP]. Cramps CRSLP116.

TUDOR, D., 1981. *Rainforest IV* [LP]. Editions Block / Gramavision, GR-EB1.

Binaural recording by John Driscoll of *Rainforest IV*, performed by Composers Inside Electronics, Berlin 1980

TUDOR, D., 1995. *Neural Synthesis Nos. 6-9* [CD]. Lovely Music LCD 1602.

TUDOR, D., 1995a. *Canaries B+W* [7 inch 45 rpm]. Bootleg. No information available except "Oklahoma City 1995".

TUDOR, D., 1996. *Three Works for Live Electronics* [CD]. Lovely Music LCD 1601.

Includes recordings of *Pulsers* (1976), *Untitled* (1972), and *Phonemes* (1981).

TUDOR, D., 1998. *Rainforest* [CD]. Mode Records 64.

Includes recordings of *Rainforest 1*, performed by David Tudor and Takehisa Kosugi 1988, and "*Sliding Pitches in the Rainforest in the Field*" (performers and dates not provided, and title inaccurate: should be simply *Rainforest 4* as the long title was only used for first performance).

TUDOR, D., 2004. *David Tudor: Live Electronic Music* [CD]. CD included with *Leonardo Music Journal*, 14.

Includes recordings of *Anima Pepsi*, from the Pepsi Pavilion at the Osaka World's Fair 1970, as well as *Toneburst* (1972) and *Dialects* (1984).

List of unreleased recordings

CAGE, J., 1960. Performance of *Cartridge Music* with David Tudor, October 10, Stockholm, Sweden. Obtained from the Cunningham Dance Foundation Archive.

CAGE, J., MUMMA, G., and TUDOR, D., 1973. Recording of *Event 72* with Merce Cunningham Dance Company, SUNY Brockport NY, April 7. Obtained from the personal archive of Gordon Mumma.

CAGE, J., MUMMA, G., and TUDOR, D., 1973a. Recording of *Event 74* with Merce Cunningham Dance Company, Kent State University OH, April 14. Obtained from the personal archive of Gordon Mumma.

CAGE, J., MUMMA, G., and TUDOR, D., 1973b. Recording of *Event 75* with Merce Cunningham Dance Company, Oberlin College OH, April 17. Obtained from the personal archive of Gordon Mumma.

CAGE, J., MUMMA, G., and TUDOR, D., 1973c. Recording of *Event 77* with Merce Cunningham Dance Company, SUNY Plattsburgh NY, April 25. Obtained from the personal archive of Gordon Mumma.

CAGE, J., MUMMA, G., TUDOR, D., and MOTHER MALLARD'S PORTABLE MASTERPIECE COMPANY, 1973. Recording of *Event 70* with Merce Cunningham Dance Company, Ithaca NY, April 1. Obtained from the personal archive of Gordon Mumma.

CIE, 1998. Binaural recording by Bob Bielecki of performance of *Rainforest 4* at Clarke Studio Theatre, Lincoln Centre. Obtained from the personal archive of John Driscoll.

DRISCOLL, J., UNDATED. Excerpts of source recordings for performance of *Rainforest 4*. Obtained from the personal archive of John Driscoll.

DRISCOLL, J., UNDATED. Excerpt of performance of *A Gift für den Geist*. Obtained from the personal archive of John Driscoll.

DRISCOLL, J., UNDATED. Excerpts of performance of *A Hall is All*. Obtained from the personal archive of John Driscoll.

DRISCOLL, J., UNDATED. Excerpts of performance of *Wafer Flats*. Obtained from the personal archive of John Driscoll.

DRISCOLL, J., 1977. Performance of *Listening Out Loud* at The Kitchen, New York City, January 7. Obtained from the archive of The Kitchen.

DRISCOLL, J., 1977a. Performance of *Under the Putting Green* at The Kitchen, New York City, January 8. Obtained from the archive of The Kitchen.

DRISCOLL, J., 1977b. Performance of *Bamboo* ("A.K.A. *Ebers and Mole*") during residency at Centre for Music Experiment, University of California San Diego, Jan.-Feb. Obtained from the personal archive of John Driscoll.

DRISCOLL, J., 1979. Performance of *Listening Out Loud* at "Dry Pool Soundings", May 7. Obtained from the personal archive of John Driscoll.

DRISCOLL, J., and EDELSTEIN, P., 1975. Performance of *Interfeed*, October 29, Albany NY. Obtained from the personal archive of Phil Edelstein.

EDELSTEIN, P., UNDATED. Rehearsal recording of *Terrain*. Obtained from the personal archive of Phil Edelstein.

EDELSTEIN, P., UNDATED A. *Slow Build to 3, Phase 2*. Obtained from the personal archive of Phil Edelstein.

EDELSTEIN, P., UNDATED B. Excerpts of source recordings for performance of *Rainforest 4*. Obtained from the personal archive of Phil Edelstein.

EDELSTEIN, P., 1970. *Zabriskie Point*, ca. 1970-71 ("original Moog patch, SUNY Albany"). Obtained from the personal archive of Phil Edelstein.

EDELSTEIN, P., 1977. Performance of *Shrieks and Nuptials* with Marsha Heather Harris at The Kitchen, New York City, January 8. Obtained from the archive of The Kitchen.

EDELSTEIN, P., and BLACK, C., 1982. *Papermusic*. Recording of Amsterdam performance. Obtained from the personal archive of Phil Edelstein.

FISHER, L., 1977. Performance of *Solo Synthesizer Music* at The Kitchen, New York City, January 6. Obtained from the archive of The Kitchen.

KALVE, M., 1978. Performance of *Earthing* at The Kitchen, New York City, September 22. Obtained from the archive of The Kitchen.

TUDOR, D., UNDATED. Performance of *Rainforest 1* with Merce Cunningham Dance Company (reel-to-reel tape in "Hi-Fi" box). Obtained from the Estate of David Tudor.

- TUDOR, D., UNDATED A. Performance of *Rainforest 1* with Merce Cunningham Dance Company (reel-to-reel tape in "Red Seal" box). Obtained from the Estate of David Tudor.
- TUDOR, D., UNDATED B. Performance of *Forest Speech*. Obtained from the Cunningham Dance Foundation Archive.
- TUDOR, D., 1966. Performance of *Bandoneon !*, October 14, New York City. Obtained from the Estate of David Tudor.
- TUDOR, D., 1970. Excerpts of source recordings from the Pepsi Pavilion, as also used in *Rainforest 3*. Obtained from the Estate of David Tudor.
- TUDOR, D., 1970a. Performance with Gordon Mumma of *Rainforest 1*, with Merce Cunningham Dance Company, Brooklyn Academy of Music, November 3. Obtained from the Estate of David Tudor.
- TUDOR, D., 1970b. Concert performance with Gordon Mumma of *Rainforest 1*, Cornell University, Ithaca NY, December 11. Obtained from the Estate of David Tudor.
- TUDOR, D., 1970c. Performance of *Pepscillator* at the Pepsi Pavilion, Osaka World's Fair. Obtained from the Estate of David Tudor.
- TUDOR, D., 1970d. Miscellaneous informal, undated recordings of David Tudor performing at the Pepsi Pavilion, Osaka World's Fair. Obtained from Experiments in Art and Technology.
- TUDOR, D., 1972. Performance with Gordon Mumma of *Rainforest 1*, with Merce Cunningham Dance Company, Brooklyn Academy of Music, February 8. Obtained from the Estate of David Tudor.
- TUDOR, D., 1972a. Simultaneous performance of *Untitled* with John Cage's *62 Mesostics re Merce Cunningham*, Radio Bremen, Germany, May 8. Obtained from Radio Bremen.
- TUDOR, D., 1972b. Simultaneous performance of *Untitled* with John Cage's *62 Mesostics re Merce Cunningham*, Royal Albert Hall, London UK, May 22. Obtained from the Estate of David Tudor.
- TUDOR, D., 1973. Source tapes for *Microphone*, produced at Mills College, Oakland CA. Obtained from the Estate of David Tudor.
- TUDOR, D., 1975. Performance of *Toneburst*. Obtained from the Estate of David Tudor.
- TUDOR, D., 1985. Performance of *Hedgehog* (excerpt). Obtained from the Estate of David Tudor.

TUDOR, D., 1987. Performance of *Web (for John Cage)* (excerpt). Obtained from the Estate of David Tudor.

TUDOR, D., 1998. Performance of *Rainforest 1* with Merce Cunningham Dance *RainForest*, Sao Paulo, Brazil, April (no date). Obtained from the Cunningham Dance Foundation Archive.

TUDOR, D., 1998a. Performance of *Rainforest 1* with Merce Cunningham Dance *RainForest*, Durham NC (no date). Obtained from the Cunningham Dance Foundation Archive.

TUDOR, D., 1998b. Performance of *Rainforest 1* with Merce Cunningham Dance *RainForest*, New Delhi India, November 3. Obtained from the Cunningham Dance Foundation Archive.

TUDOR, D., 1998c. Performance of *Rainforest 1* with Merce Cunningham Dance *RainForest*, Le Havre, France (no date). Obtained from the Cunningham Dance Foundation Archive.

TUDOR, D., 1998d. Performance of *Lines and Reflections*, Akademie der Künste, Dusseldorf, Germany. Obtained from the Estate of David Tudor.

TUDOR, D., 1990. Performance of *Virtual Focus* with Merce Cunningham dance *Polarity*, Paris, October (no date). Obtained from the Cunningham Dance Foundation Archive.

TUDOR, D., 1990a. Performance of *Rainforest 1* with Merce Cunningham Dance *RainForest*, New Delhi India, November 3. Obtained from the Cunningham Dance Foundation Archive.

TUDOR, D., 1991. Performance of *Weatherings* with Merce Cunningham dance *Exchange*, Paris, September 11. Obtained from the Cunningham Dance Foundation Archive.

TUDOR, D., and CIE, 1974. Performance of *Rainforest 4* at the Everson Museum, Syracuse NY, March 8. Obtained from the personal archive of Linda Fisher.

TUDOR, D., and CIE, 1974a. Performance of *Rainforest 4* at Synapse Cable TV studio, Syracuse NY, March 9. Obtained from the personal archive of Linda Fisher.

TUDOR, D., and CIE, 1976. Studio performance of *Rainforest 4* November 20, New York City, recorded for Dance In America videotape by Merce Cunningham Dance Company. Obtained from the Cunningham Dance Foundation Archive.

TUDOR, D., and CIE, 1977. Performance of *Rainforest 4* at the Centre for Music Experiment, University of California San Diego, February (no date). Obtained from the Cunningham Dance Foundation Archive.

TUDOR, D., and CIE, 1979. Performance of *Rainforest 4* at the Institute of Contemporary Art, Philadelphia PA, April (no date). Obtained from the personal archive of John Driscoll.

TUDOR, D., and CIE, 1980. Performance of *Rainforest 4* at the Moderna Museet, Stockholm, Sweden, January (no date). Obtained from the personal archive of John Driscoll.

TUDOR, D., and CIE, 1982. Performance of *Rainforest 4* at the Stedelijk Museum, Amsterdam, Netherlands, June (no date). Obtained from the personal archive of John Driscoll.

VIOLA, B., 1977. Performance of *Gong* at The Kitchen, New York City, January 8. Obtained from the archive of The Kitchen.

WBFO, 1978. Interview with David Tudor, John Driscoll, Ralph Jones, and Martin Kalve, "Plastic" [title of show] with host Mark Fruehauf, December 5. Includes excerpts of *Ebers and Mole - Interfeed* (John Driscoll, recorded September 20 1978, The Kitchen, New York City), *Rumble in the Backseat* (Martin Kalve, no info), and *Star Networks at the Singing Point* (Ralph Jones, recorded September 21 1978, The Kitchen, New York City). Recording of broadcast obtained from the personal archive of John Driscoll.

Audio examples CD accompanying

**IDEA AND COMMUNITY: THE GROWTH OF
DAVID TUDOR'S *RAINFOREST*, 1965-2006**

by Matthew R. Rogalsky

A thesis submitted to the Music Department,
City University London, in partial fulfillment of requirements
for the degree of Doctor of Philosophy

April 2006

Detailed track listing is provided on pages 10-12 of the thesis.

This CD may not be copied.