



City Research Online

City, University of London Institutional Repository

Citation: Zhou, L. (2010). Smart grid analysis with particular references to power quality and load forecast. (Unpublished Doctoral thesis, City University London)

This is the accepted version of the paper.

This version of the publication may differ from the final published version.

Permanent repository link: <https://openaccess.city.ac.uk/id/eprint/8709/>

Link to published version:

Copyright: City Research Online aims to make research outputs of City, University of London available to a wider audience. Copyright and Moral Rights remain with the author(s) and/or copyright holders. URLs from City Research Online may be freely distributed and linked to.

Reuse: Copies of full items can be used for personal research or study, educational, or not-for-profit purposes without prior permission or charge. Provided that the authors, title and full bibliographic details are credited, a hyperlink and/or URL is given for the original metadata page and the content is not changed in any way.



**CITY UNIVERSITY
LONDON**

**SMART GRID ANALYSIS WITH PARTICULAR
REFERENCES TO POWER QUALITY AND LOAD
FORECAST**

by

Long Zhou

This thesis is submitted for the Degree of

Doctor of Philosophy

at

City University London

School of Engineering and Mathematical Sciences

June 2010

TABLE OF CONTENTS

TABLE OF CONTENTS.....	II
ACKNOWLEDGEMENTS.....	VI
LIST OF PUBLICATIONS.....	VII
LIST OF FIGURES.....	IX
LIST OF TABLES.....	XI
LIST OF ABBREVIATIONS.....	XII
COPYRIGHT DECLARATION.....	XIV
ABSTRACT.....	XV
Chapter 1 Introduction.....	1
1.1 Organization of Thesis.....	1
1.2 Original Contribution.....	3
Chapter 2 Smart Grid.....	6
2.1 Introduction.....	6
2.2 The Concept of Smart Grid.....	6
2.3 Strategic Planning in Smart Grid.....	7
2.3.1 Bulk Generation.....	7
2.3.2 Transmission.....	8
2.3.3 Distribution.....	9
2.3.4 Customer.....	10
2.3.5 Operations.....	10
2.3.6 Markets.....	11
2.3.7 Service Provider.....	12
2.4 Drivers for develop the Smart Grid.....	13
2.5 Key Characteristics of Smart Grid.....	14
2.6 Technologies of the Smart Grid.....	16
2.7 Benefits in Implementing Smart Grid.....	18
2.8 Key Challenges of Smart Grid (the future) in UK.....	19

2.9 Implementation Sequence and Steps to Smart Grid.....	19
2.10 Conclusion.....	21
Chapter 3 Impact of Smart Metering on Energy Efficiency.....	22
3.1 Introduction.....	22
3.2 Smart Metering	22
3.3 Standard and Policy of Smart Metering.....	24
3.3.1 Standard and Policy in EU.....	24
3.3.2 Standard and Policy in Australia.....	25
3.3.3 Standard and Policy in China.....	26
3.3.4 Standards from companies.....	28
3.4 Smart Metering Impact on Energy Efficiency.....	29
3.5 Smart Metering Case Study Worldwide.....	30
3.5.1 Imminent implementation of smart metering in UK.....	30
3.5.2 China smart meter and smart grid project.....	31
3.5.3 Smart metering projects in Italy.....	32
3.5.4 Smart metering implementation in United States.....	34
3.5.5 Smart metering implementation in other countries.....	36
3.6 Conclusion.....	38
Chapter 4 Signal Processing for Power Quality Analysis.....	39
4.1 Introduction.....	39
4.2 History of Wavelets.....	40
4.3 Wavelets and Wavelet Transform.....	43
4.3.1 The Continuous Wavelet Transform (CWT).....	44
4.3.2 The Discrete Wavelet Transform (DWT).....	45
4.4 Wavelet Applications in Power Engineering.....	47
4.4.1 Application of WT for Harmonic Analysis.....	47
4.4.2 Power Disturbance Network/System Analysis.....	48
4.4.3 Power Devices Protection.....	48

4.4.4 Power Disturbance Identification and Classification.....	48
4.4.5 Power Disturbance Detection and Localization.....	48
4.5 Conclusion.....	49
Chapter 5 Wavelet-Based Algorithm for Harmonic Analysis.....	50
5.1 Introduction.....	50
5.2 Wavelet transform and wavelet.....	51
5.3 Harmonics detection.....	54
5.4 Discrimination of adjacent frequencies.....	55
5.5 Sampling frequency and signal length.....	57
5.6 The proposed harmonics detection algorithm.....	59
5.7 Simulation Results Based on Synthesized Waveforms.....	59
5.8 Conclusion.....	67
Chapter 6 Wavelet-Based Algorithm for Nonstationary Power System Waveform Analysis.....	68
6.1 Introduction.....	68
6.2 Waveform Reconstruction Algorithm.....	69
6.3 Synthesized Waveforms Reconstruction.....	72
6.4 Experimental Results.....	74
6.5 Conclusion.....	78
Chapter 7 Detection of Voltage Variations due to Distributed Energy Resources.....	79
7.1 Introduction.....	79
7.2 Wavelet-Based Analysis Algorithm.....	80
7.3 Simulation Settings.....	82
7.4 Simulation Results.....	84
7.5 Conclusion.....	88

Chapter 8 Wavelet-GA-ANN Based Hybrid Model for Accurate Prediction of Short-Term Load Forecast.....	89
8.1 Introduction.....	89
8.2 Wavelet Transforms in Load Forecast.....	92
8.2.1 Time series and wavelet decomposition in load forecasting.....	92
8.3 Radial Basis Networks.....	96
8.3.1 A hybrid Neural-Wavelet model for short-term load prediction.....	98
8.4 Experimental Results.....	102
8.5 Conclusion.....	104
Chapter 9 Conclusions and Future work.....	105
9.1 Overall conclusion.....	105
9.2 Trends and Further work.....	106
Appendix MATLAB code.....	108
REFERENCES.....	111

ACKNOWLEDGEMENTS

I would like to express my deepest appreciation and sincere gratitude to my Ph.D supervisor Professor L.L.Lai, Head of Energy System Group, City University London for his support, patience, direction and valuable supervision throughout my research work. Without Professor Lai, my Ph.D study is hardly able to be finished. Many times when my research was stuck by difficult mathematics, unexpected simulation results, Professor Lai's encouragements and insightful advices often came just in time and helped to raise my aspirations. I am indebted to Professor Lai for his valuable time and effort amid his busy schedule.

I am debated to many of my colleagues at energy system group who directly helped me in accomplishment of my research work. I would like to thank Yingnan.Ma, Fangyuan.Xu for encouragement of over these challenging years.

Last but not least, I would like to express my deepest appreciation and sincere gratitude to my parents, Yuefeng.Zhou and Xiaoling.Wang for their full financial supports, patience, love, inspiration and understanding during all my four years in UK even they are eight thousand miles away.

I am truly grateful to my parents.

LIST OF PUBLICATIONS

- [1] Long.Zhou, L.L.Lai, "Signal Processing for Improving Power Quality", Book Chapter for "Handbook of Power Systems", Vol.2, pp55-100, ISBN: 978-3-642-02492-7, © Springer-Verlag Berlin Heidelberg 2010
- [2] Norman C. F. Tse, Long.Zhou, "Wavelet-based Algorithm for Power Quality Analysis", EUROPEAN TRANSACTIONS ON ELECTRICAL POWER, ISSS 1430-144X, © John Wiley & Sons, Ltd, *SCI Index*
- [3] Norman C. F. Tse, Long.Zhou, L.L.Lai, "Wavelet-Based Algorithm for Nonstationary Power System Waveform Analysis", Proceedings of 2008 International Conference on Analysis and Pattern Recognition IEEE (ICWAPR 2008), 2008.08, pp729-735, ISBN: 978-1-4244-2238-8
- [4] Norman C. F. Tse, Long.Zhou, "Detection of Voltage Variations due to Distributed Energy Resources", 2009 Power & Energy Society General Meeting IEEE (PESGM 2009), 2009.07, pp1-5, ISSN: 1944-9925
- [5] Y.N.Ma, Long.Zhou, Norman C. F. Tse, Abdi Osman, L.L.Lai, "An Initial Study on Computational Intelligence for Smart Grid", Proceedings of 2009 International Conference on Machine Learning and Cybernetics IEEE (ICMLC 2009), 2009.07, pp3425-3429, ISBN: 978-1-4244-3702-3
- [6] Fang.Yuan.Xu, Long.Zhou, Y.N.Ma, L.L.Lai, "Extending version of Graphical User Interface in Neural Network Toolbox of MATLAB and engineering applications", Proceedings of 2009 International Conference on Machine Learning and Cybernetics IEEE (ICMLC 2009), 2009.07, pp187-192, ISBN: 978-1-4244-3702-3

[7] Fang.Yuan.Xu, Long.Zhou, Yi.Lin.Wu, Y.N.Ma, “Standards, Policies and Case studies in Smart Metering”, 2010 Power & Energy Society General Meeting IEEE (PESGM 2010), 2010.07 (*in print*)

[8] Long.Zhou, Fang.Yuan.Xu, Y.N.Ma, “Impact of Smart Metering on Energy Efficiency”, Proceedings of 2010 International Conference on Machine Learning and Cybernetics IEEE (ICMLC 2010), 2010.07 (*in print*)

[9] Fang.Yuan.Xu, Long.Zhou, L.L.Lai, “Application of Artificial Neural Network in Electrical Analysis of Micro-Grid Load”, 2010 Power & Energy Society General Meeting IEEE (PESGM 2010), 2010.07 (*in print*)

[10] Fang.Yuan.Xu, M.C.Leung, Long Zhou, “A RBF Network for Short – term Load Forecast in Micro-grid”, 2010 Power & Energy Society General Meeting IEEE (PESGM 2010), 2010.07 (*in print*)

[11] Hao.Tian.Zhang, Fang.Yuan.Xu, Long.Zhou, “Artificial Neural Network for Load Forecasting in Smart Grid”, Proceedings of 2010 International Conference on Machine Learning and Cybernetics IEEE (ICMLC 2010), 2010.07 (*in print*)

LIST OF FIGURES

Fig.2.1 NIST Smart Grid Framework.....	7
Fig.2.2 Bulk Generation.....	8
Fig.2.3 Transmission.....	9
Fig.2.4 Distribution.....	9
Fig.2.5 Customer.....	10
Fig.2.6 Operations.....	11
Fig.2.7 Markets.....	12
Fig.2.8 Service Provider.....	12
Fig.3.1 Structure of Smart Metering.....	23
Fig.3.2 Structure of Zigbee Network.....	29
Fig.3.3 Overview of a Typical Smart Meter.....	30
Fig.4.1 Comparing sine wave and wavelet.....	41
Fig.4.2 Different Mother Wavelet.....	42
Fig.4.3 Fourier Transform.....	44
Fig.4.4 Continuous Wavelet Transform.....	45
Fig.4.5 Approximations and Details.....	46
Fig.4.6 Downsampling.....	47
Fig.5.1 Filter banks by CMW.....	52
Fig.5.2 Filter banks by the modified CMW.....	54
Fig.5.3 Fourier Transform of modified CMWs with $f_c=f_1$ & f_2	56
Fig.5.4 Flow chart of the proposed algorithm.....	59
Fig.5.5 The synthesized waveform for Test 1.....	61
Fig.5.6 The synthesized waveform for Test 2.....	62
Fig. 5.7 Amplitude variation at 49.5Hz by the proposed algorithm.....	65
Fig.5.8 Amplitude variation at 148.5Hz by the proposed algorithm.....	65
Fig.5.9 Amplitude variation at 247.5Hz by the proposed algorithm.....	66

Fig.6.1 Flow chart of the WT-based waveform reconstruction algorithm.....72

Fig.6.2 Synthesized waveform vs. Reconstructed Waveform.....73

Fig.6.3 Waveform of two cycles of VSD input current.....75

Fig.6.4 Field harmonic signal vs. reconstructed fundamental & 5th harmonic waveform.....76

Fig.6.5 Waveform of four cycles of single-phase input current.....77

Fig.6.6 Field harmonic signal vs. reconstructed fundamental & 3rd harmonic waveform.....77

Fig.7.1 Simulated signal.....83

Fig.7.2 Oscillatory transient.....84

Fig.7.3 Wavelet ridges plot.....85

Fig.7.4 Reconstructed fundamental waveform.....86

Fig.7.5 Reconstructed waveform at 2000Hz.....87

Fig.8.1 Wavelet Decomposition Process.....94

Fig.8.2. Wavelet Transform of a Time-Series Signal.....96

Fig.8.3 Wavelet Recombination Process.....96

Fig.8.4. Overview of the neural-wavelet multiresolution forecasting system. w_1, \dots, w_k are wavelet coefficients, c is the residual coefficient series.....99

Fig.8.5 Illustrations of the à trous wavelet decomposition of a series of electricity demand.....100

LIST OF TABLES

Table.2.1 Current power grid vs. Smart Grid.....	14
Table.3.1 EU committee on Smart Metering.....	25
Table.3.2 MCE Response on Initial Functions to Be Included in the National Minimum Functionality for Smart Meters.....	26
Table.3.3 Standards of Smart Meters in China.....	27
Table.3.4 Abilities integrated in Smart meters.....	33
Table.3.5 Part of schedule of Series of FORUMS.....	37
Table 5.1 Harmonic contents of the synthesized waveform.....	60
Table 5.2 Estimated results by the proposed algorithm & DFT for Test 1.....	61
Table 5.3 Estimated results by the proposed algorithm & DFT for Test 2.....	63
Table.6.1 Synthesized waveform vs. Reconstructed Waveform.....	74
Table.7.1 Comparison of Detection Results.....	85
Table.7.2 Comparison of sudden waveform change locations.....	87
Table.8.1 Load forecast performance on testing data on APE measure for FPGA optimized spread factor and input.....	100

LIST OF ABBREVIATIONS

AI	Artificial Intelligence
ANN	Artificial Neural Network
CMW	Complex Morlet Wavelet
CWT	Continuous Wavelet Transform
D-CWT	Discretised Continuous Wavelet Transform
DFT	Discrete Fourier Transform
DG	Distributed Generation
DSP	Digital Signal Processing
DTFT	Discrete Time Fourier Transform
DWT	Discrete Wavelet Transform
FFT	Fast Fourier Transform
FPGA	Floating Point Genetic Algorithm
FS	Fourier Series
GA	Genetic Algorithm
HF	High-Pass
IDFT	Inverse Discrete Fourier Transform
LF	Low-Pass
LF	Low Forecast
LVQ	Learning Vector Quantization
MLP	Multi-Layer Perceptron
N-DFT	N-Point Discrete Fourier Transform
NIST	National Institute of Standards and Technology
OLS	Orthogonal Least Squares
QMF	Quadrature Mirror Filter
RBF	Radial Basis Function
STFT	Short-Time Fourier Transform
STLF	Short-term Load Forecast

VSD

Variable Speed Drive

WBTA

Wavelet-Based Transient Analysis

WT

Wavelet Transform

COPYRIGHT DECLARATION

The author grant power of discretion to the City University London Librarian to allow this thesis to be copied in whole or in part without reference to author. This permission covers only single copies made for study purposes, subject to normal conditions of acknowledgement.

Long Zhou

London, June 2010

ABSTRACT

The electricity industry was designed more than 50 years ago when the load and generation was less, now we are in the information age with a digital society where the demand is very high, this has forced the electricity infrastructure to its limits which was not designed for, in addition, the electricity demand continues to grow. So the focus of the question becomes what we need to do from technology prospective to meet that growing demand for electricity, and do it in a way that we don't create a greater carbon footprint.

Smart grid is the next generation of the electricity infrastructure based on the optimisation of the current system in all levels. Since the current system is facing various problems from increasing disturbances, system is operating on the limit, aging equipments, load change etc. therefore an improvement is essential to minimize these problems. To enhance the current system and resolve the issues that it's facing, Smart grid must have the right tools to solve it and reduce it.

First of all, this thesis gives a brief concept of smart grid and summarizes many issues about smart grid, such as strategy planning, drivers for develop the Smart Grid, key characteristics, technologies of the Smart Grid, benefits in implementing Smart Grid, key Challenges, implementation sequence. And then this thesis discusses smart metering system and its standards.

Secondly, this thesis reports on development of a new approach to deal with power quality problem. Wavelet Transform (WT) is used for the new approach. Complex Morlet Wavelet (CMW) is selected for the new approach introduced in this thesis.

The proposed algorithm is able to identify all harmonic components including integer, non-integer and sub-harmonics. Comparing with DFT, the proposed algorithm achieves exact estimation of the harmonic frequency.

Thirdly, reports on the development of a WT-based dynamic waveform reconstruction algorithm which is able to identify amplitude variations of harmonic components of the distorted waveform in the examined period.

At last, this thesis reports a new Wavelet-GA-ANN based hybrid model for accurate prediction of short-term load forecast. Finally, the conclusions and future work will be given.

Chapter 1

Introduction

The electricity industry was designed more than 50 years ago when the load and generation was less, now we are in the information age with a digital society where the demand is very high, this has forced the electricity infrastructure to its limits which was not designed for, in addition, the electricity demand continues to grow. So the focus of the question becomes what we need to do from technology prospective to meet that growing demand for electricity, and do it in a way that we don't create a greater carbon footprint.

The electricity network is facing lot of problems, from deregulation and load increase to plant problems this is because the system was not designed to operate at that level, such problems lead to major events and paralyse the electricity system as we have witnessed in the past. The increasing demand and aging infrastructure made it difficult to make the system up to date this made the system complex, to overcome such complexity we have to come up with a grand solution to such problem, in other words we need to make the grid more modern and smarter that is, generating the electricity and transmit and distribute in smarter way [1-9].

Power quality has become a very important issue for smart grid. Harmonic currents produced by distributed resources and nonlinear loads would cause extra loss in the smart grid. On the other hand, harmonic currents will increase energy cost and carbon emission. Voltage harmonics caused by harmonic voltage drops in the distribution cables are affecting the normal operation of voltage sensitive equipment as well.

Chapters 3-8 are using a few of skills and techniques to deal with the harmonic currents and voltage harmonics which are caused by smart equipments. Those algorithm and techniques are important for the smart grid. Using smart grid features of integrating AI technology in the network promises to bring higher quality power and low harmonics while simultaneously supporting power flow.

1.1 Organization of Thesis

This thesis summarizes on the research study findings to achieve the two objectives, which are smart grid and power quality analysis. The thesis consists of nine chapters.

Chapter 2 gives a brief concept of smart grid. And chapter 2 also describes what the smart grid is. Furthermore, chapter 2 summarizes many issues about smart grid, such as strategy planning, drivers for develop the Smart Grid, key characteristics, technologies of the Smart Grid, benefits in implementing Smart Grid, key Challenges, implementation sequence and so on.

Chapter 3 introduces smart metering system. And what impact of Smart Metering on Energy Efficiency is. This chapter gives standards and policies of smart metering system in different countries. It also summarizes smart metering case study in many developed and developing countries, such as UK, The USA, China, Italy and so on.

Chapter 4 focuses on signal processing for power quality analysis. Due to the power quality problem in smart grid, signal processing is one of the optimal methods to deal with. The main tool is wavelet transform. This chapter describes the history and gives a brief introduction to wavelet and wavelet transform. This chapter also briefly describes the origin of invention and the definitions of Wavelet Transform. The recent applications of WT in power engineering are also discussed.

Chapter 5 describes a new approach for harmonic analysis. This approach based on Continuous Wavelet Transform which does not have the limitations of Fourier Transform-based harmonic analysis. The Continuous Wavelet Transform is used to transform a time signal into a time-frequency representation. Both time information and frequency information are contained in the wavelet coefficients.

This chapter presents an algorithm based on continuous wavelet transform to identify harmonics in a power signal. The new algorithm is able to identify the frequencies,

amplitudes and phase information of all distortion harmonic components, including integer harmonics, sub-harmonics and inter-harmonics.

Chapter 6 discusses the development of a WT-based waveform reconstruction algorithm for reconstructing the harmonic waveforms from the complex CWT coefficients. This is useful for identifying the amplitude variations of the nonstationary harmonics over the estimation period.

Chapter 7 presents the application studies by using the proposed WT-based algorithm for distributed energy resources. The sensitivity of the WT-based algorithm to harmonics with very small amplitudes is also estimated. The algorithm is then applied to two real field harmonic signals. The first field harmonic signal is obtained from line current input to three-phase variable speed drive and the second field harmonic signal is obtained from the line current input to a group of single-phase loads.

Chapter 8 presents a new Wavelet-GA-ANN based hybrid model for accurate prediction of short-term load forecast. Autocorrelation shell representation base wavelet transform is used to approximate Short-term Load Forecast (STLF) at different levels of resolution using multi-resolution decomposition. This decomposed data is used for training the RBF network for predicting the wavelet coefficients of future loads. RBF networks optimized with the help of FPGA (Floating Point Genetic Algorithm). This technique is applied to build Neural-Wavelet based forecasting models to predict electricity demand as from the data obtained from a real electricity market. An accurate load forecast prediction is a very important issue for smart grid.

Chapter 9 summarizes the work done in the research study. Future work and developments areas are suggested, such as smarter grid. And renewable energy will have an impact on the future grid development and evolution. Intelligent techniques will be widely used in the future smart grid, which should be smarter grid.

1.2 Original Contribution

1. Classification and comparison of smart metering standards and policies in different areas. Due to the classification and comparison, they reveal many advantages and disadvantages in different areas. It can give a better experience to develop future smarter grid for those countries. It also can give many other countries a good tutorial in developing in smart metering system. (Chapter 2)

2. The Complex Morlet Wavelet is modified to enhance the accuracy in estimating higher order harmonics with very small amplitudes. (Chapter 5)

3. Wavelet ridges are used to extract frequency and amplitude information from the complex wavelet coefficients. The initial phase angles of harmonics are estimated from the complex wavelet coefficients. (Chapter 5)

4. The setting of the CMW parameters is derived in relation to sampling frequency, waveform length and discrimination of adjacent frequencies. Useful formulae are derived for accurate and efficient estimation of harmonics in power system waveforms. (Chapter 5)

5. An adaptive wavelet dilation procedure is suggested. When computing wavelet coefficients, wavelet dilations are estimated from the frequency bandwidth of the power system waveform, with frequency dilation steps determined by the required frequency resolution. (Chapter 5)

6. Development of a WT-based dynamic waveform reconstruction algorithm for reconstruction of time-variant harmonics waveforms. The algorithm is capable of showing the variation of amplitudes of harmonics over time. The waveform reconstruction algorithm was tested with synthesized harmonic signals and field harmonic signals. (Chapter 6)

7. Development of a new Wavelet-GA-ANN based hybrid model for accurate prediction of short-term load forecast. The model was tested with the data obtained from a real electricity market. (Chapter 8)

Therefore, Chapter 2, chapter 3, chapter 5, chapter 6 and chapter 7 are major parts. Chapter 4, chapter 8 and chapter 9 are minor parts.

Chapter 2

Smart Grid

2.1 Introduction

Smart grid is the next generation of the electricity infrastructure based on the optimisation of the current system in all levels. Since the current system is facing various problems from increasing disturbances, system is operating on the limit, aging equipments, load change etc. therefore an improvement is essential to minimize these problems. To enhance the current system and resolve the issues that it's facing, Smart grid must have the right tools to solve it and reduce it.

Power disturbances can be increased by transmission line switching, capacitor switching, lightning strikes, faulty conductors and equipment failures. Different types of power disturbances depend on different sources.

This chapter proposes a framework on how computational intelligence may be applied in developing smart grid to improve reliability and security of power system. Some examples will be used to demonstrate the feasibility.

2.2 The Concept of Smart Grid

“A Smart Grid is an electricity network that can intelligently integrate the actions of all users [10].” Smart grid provides a conceptual framework that defines new criteria and implementation of a reliable power delivery grid. A transformed electricity transmission and distribution grid that uses robust two-way communications, advanced sensors, and distributed computers to improve the efficiency, reliability and safety of power delivery and use.

The smart grid is the power system that is capable of assessing its health in real-time, predicting its behaviour, anticipatory behaviour, adaption to new environments, handling distributed resources, stochastic demand, and optimal response to the smart appliances.[11]

2.3 Strategic Planning in Smart Grid

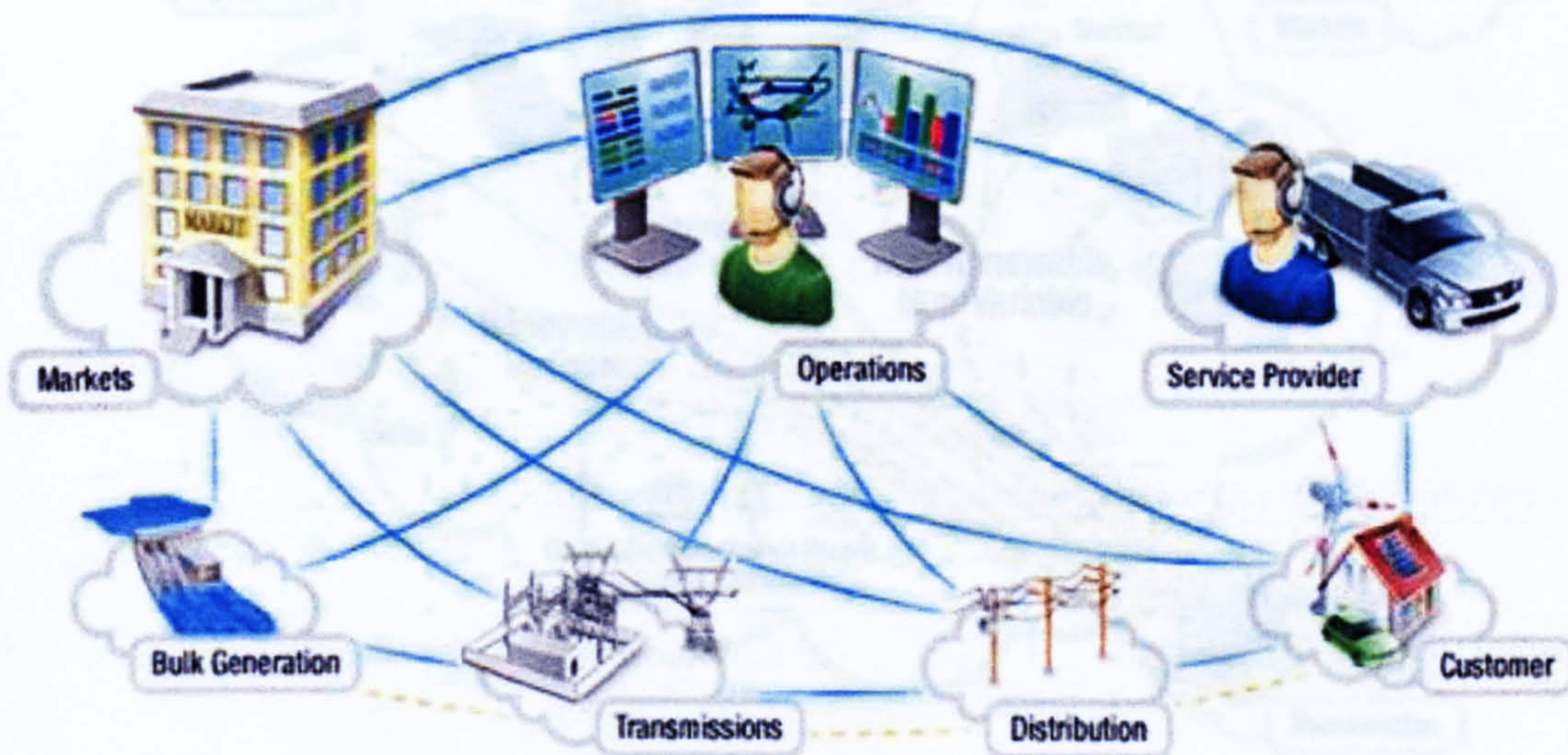

Fig.2.1 NIST Smart Grid Framework [12]

“The National Institute of Standards and Technology (NIST) Smart Grid Conceptual model provides a high level framework that defines seven important Smart Grid domains: Bulk Generation, Transmission, Distribution, Customers, Operations, Markets and Service Providers[d].” The Fig.2.1 shows all the power flows and communications connecting each part and how they are related to each other. Furthermore, every part contains a few very important Smart Grid elements connected to each other through two-way communication paths, which are the basis of the smart grid in the future. [12]

2.3.1 Bulk Generation

The bulk generation part generates electricity from renewable and non-renewable resources in bulk power plants. These resources can be classified as renewable variable sources, as like wind and solar; renewable non-variable, such like hydro, biomass, geothermal, pump storage or non-renewable, non-variable, such as nuclear, coal, gas. It may also contain energy storage for later distribution. [13]

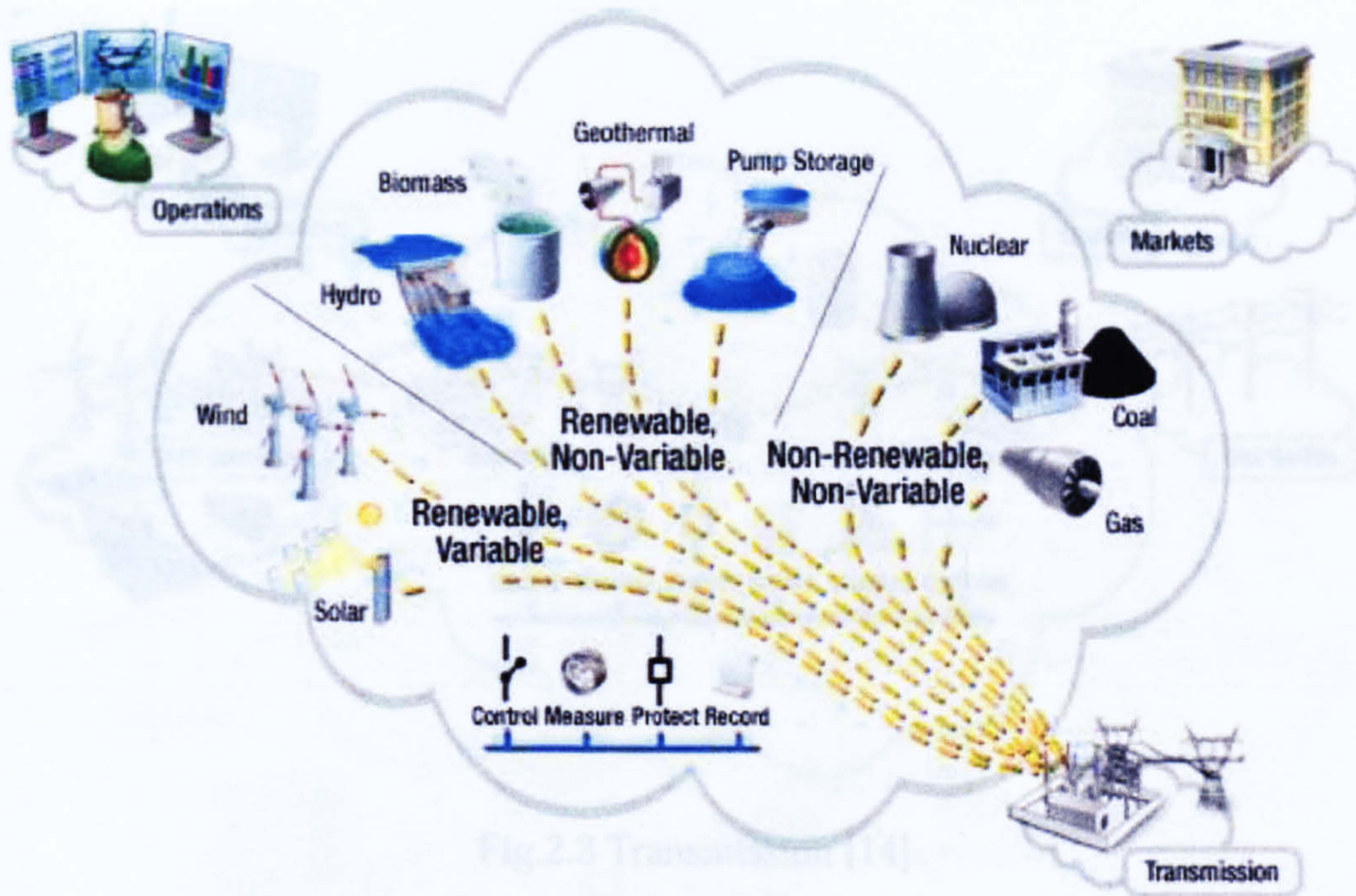

Fig.2.2 Bulk Generation [13]

2.3.2 Transmission

The transmission part takes bulk electricity through transmission lines over long distance, connecting the bulk generation to the energy consumption centres of the smart grid. It also includes the power system substations; the transmission and the distribution substations. It also can connect to energy storage facilities and optional distributed energy resources at the transmission platform. [14]

2.3.4 Customer

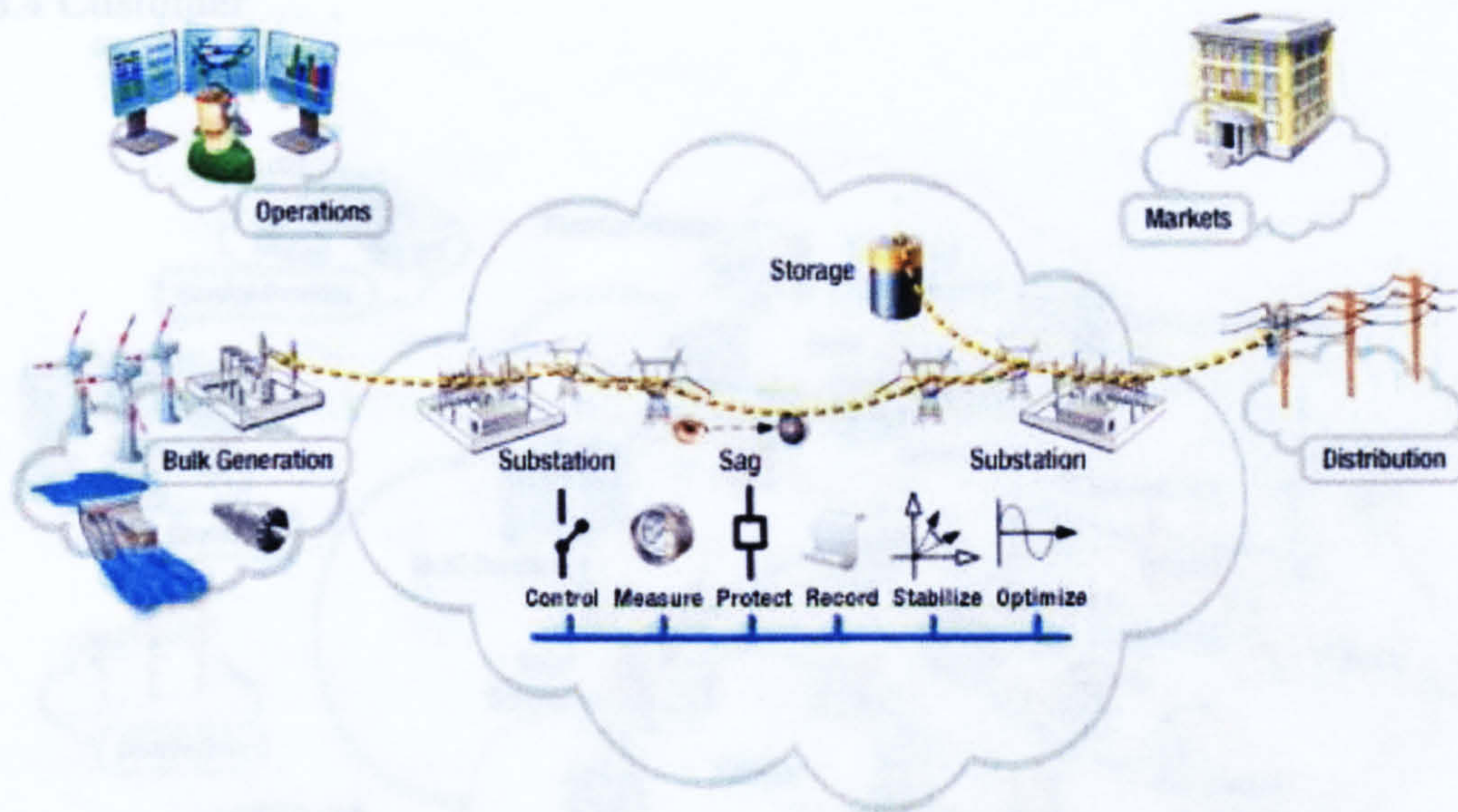

Fig.2.3 Transmission [14]

2.3.3 Distribution

The smart distribution part distributes the electricity to and from the end users. The smart distribution network connects the smart metering system and all intelligent field devices. The smart distribution network manages and controls them through a two-way wireless or wire line communication network. It also can connect to energy storage facilities and optional distributed energy resources at the distribution platform. [15]

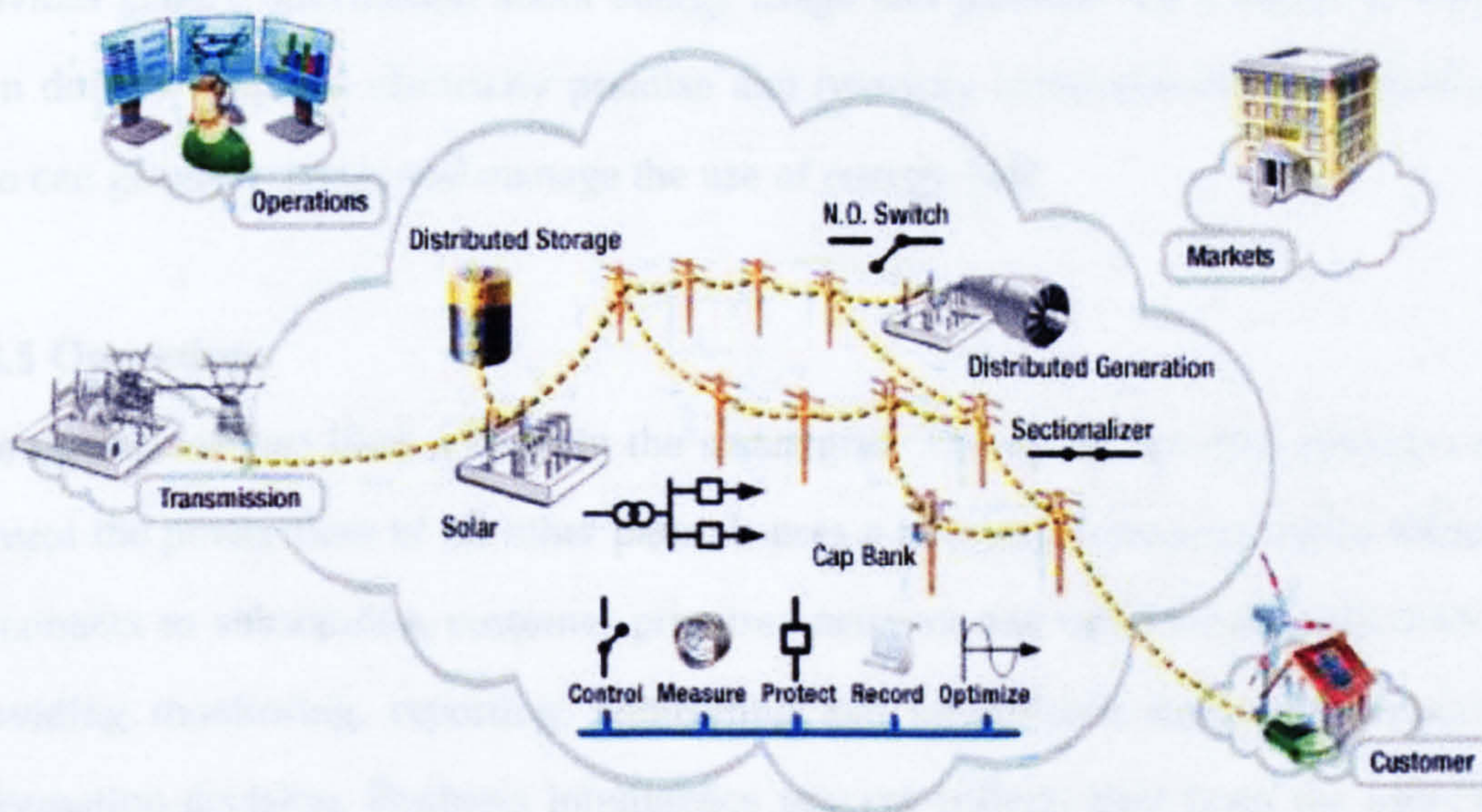

Fig.2.4 Distribution [15]

2.3.4 Customer

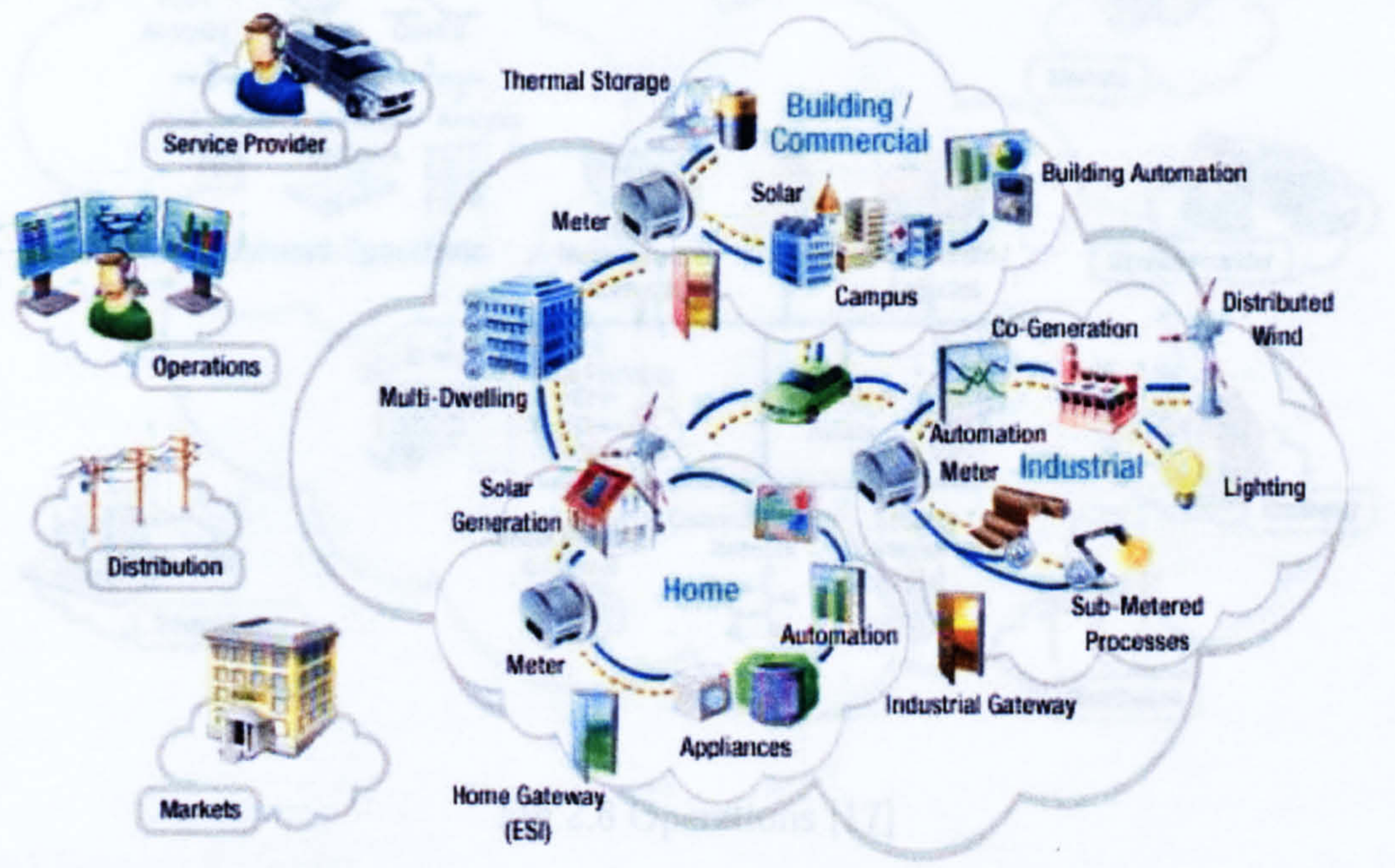

Fig.2.5 Customer [16]

2.3.6 Markets

The customer part is the end users (home, building and industries) of electricity. They connect to the smart electric distribution grid through the smart metering system. The smart metering system controls and manages the power flow to the customers and provides energy information about energy usage and patterns. Each customer has its own domain contains electricity premise and two-way communications networks. It also can generate, store, and manage the use of energy. [16]

2.3.5 Operations

The operations part likes a brain in the smart grid. The operations part manages and control the power flow of all other parts. It uses a two-way communications network to connect to substations, customer premises network and other smart field devices, providing monitoring, reporting, controlling and supervision status and important information decision. Business intelligence process collects data from the users and grid to support the decision making. [17]

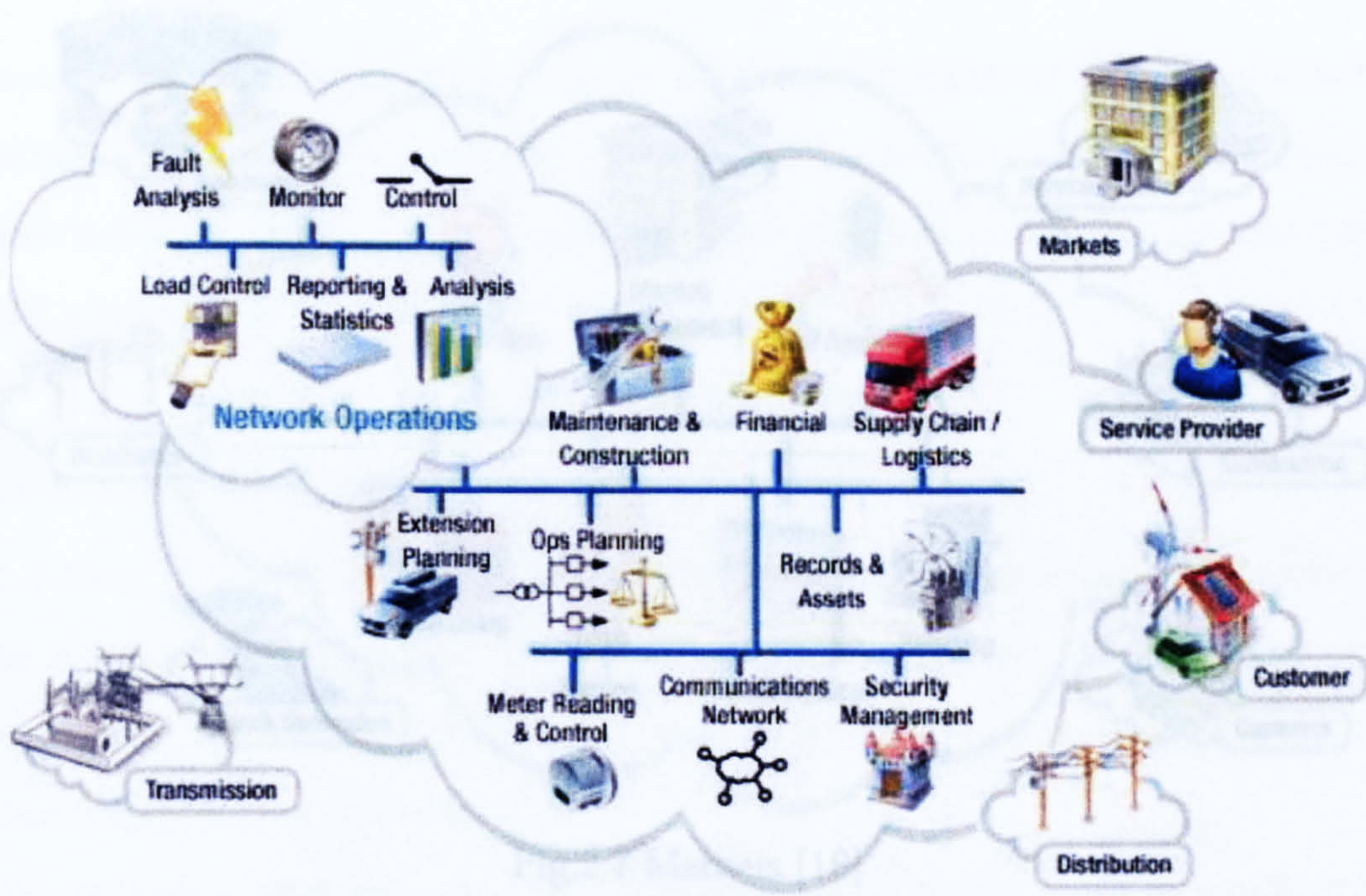

Fig.2.6 Operations [17]

2.3.7 Service Provider

2.3.6 Markets

The markets part operates and coordinates the participants in electricity markets. It provides the market management, the wholesaling, the retailing and trading of energy services operation. It interfaces with all other platforms and makes sure they are coordinated in a competitive market. The markets also can handle the energy information clearinghouse operation and information communication with the third party service providers. [18]

Fig.2.8 Service Provider [19]

The service provider part is an independent part in the smart grid framework. It can be operated by utilities or government. The service provider part controls all third party operations within the domains, such like the end users energy efficiency management

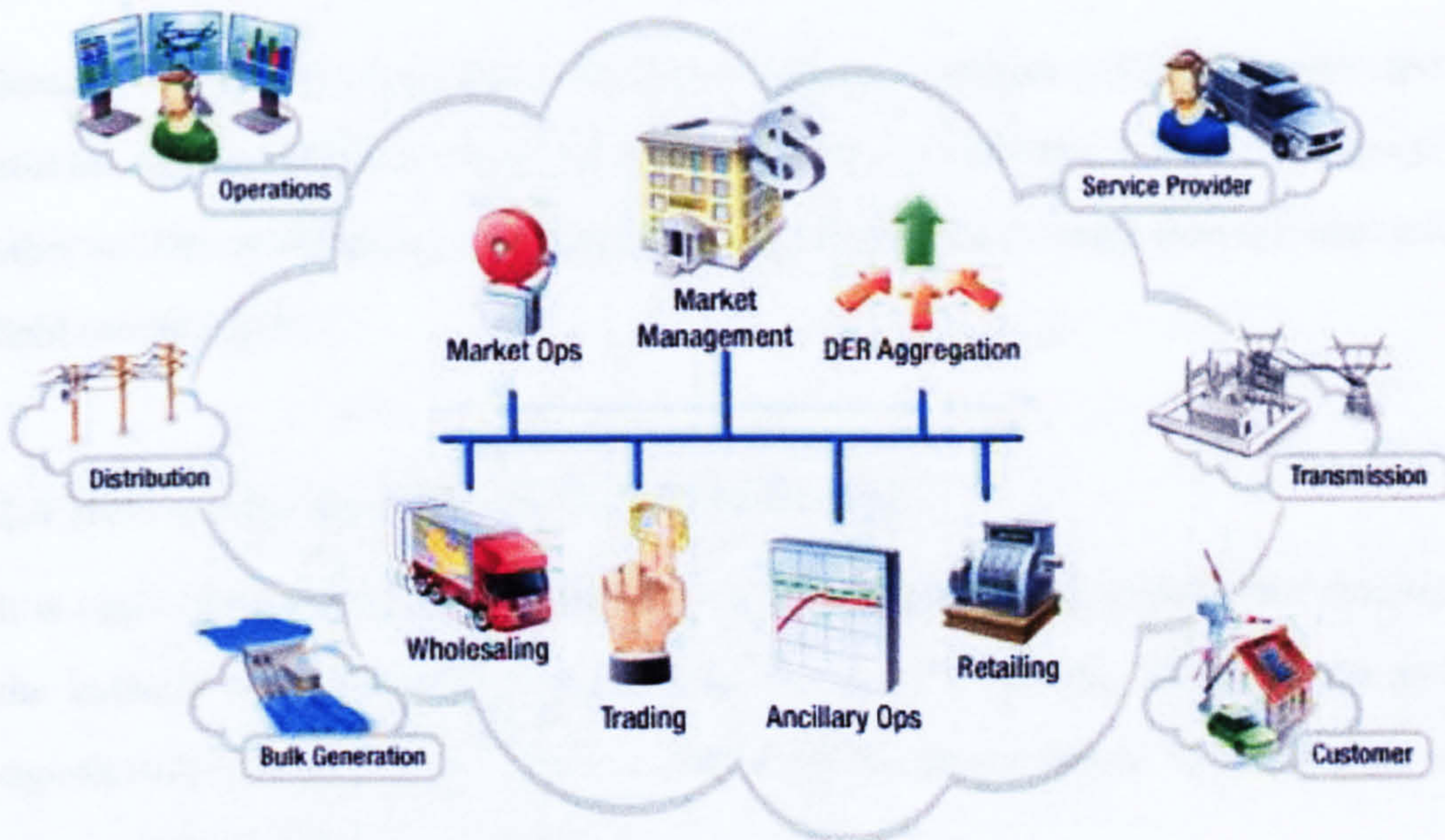

Fig.2.7 Markets [18]

2.3.7 Service Provider



Fig.2.8 Service Provider [19]

The service provider part is an independent part in the smart grid framework. It can be operated by utilities or government. The service provider part controls all third party operations within the domains, such like the end users energy efficiency management

through energy web entry, data exchange for energy management between user and utilities, and the electricity supplied to households and buildings. It also can manage other utilities processes such as demand response programs, outage management and field services. [19]

2.4 Drivers for develop the Smart Grid [20]

It is essential to understand what are the drivers that push smart grids? Until recently the industry was considering smart grids mainly as a concept. This has changed significantly recently. The physical transition of the power system to smart grids is already underway in some countries.

Players tend to adopt state-of-the-art systems, but there is also a risk of insufficient investments at the production level in some countries which will force regulators to consider new incentives to support grid operation in minimum reserve scenarios as too high risk of blackout is reached.

Without the corresponding development of technical, market and regulatory frameworks in the next few years the current decentralized system will become unstable and unable to accept further deployment of distributed generation.

The amount of “regulating energy” provision is increasing in value with the increase in stress on the system while the governments continue to strive for distributed resource penetration and is launching new energy efficiency ideas.

System management costs are increasing, and the threat to system security is an increasing concern as installed distributed generating capacity in some areas exceeds local demand.

Environmental issues such as conservation, “zero emission buildings”, and grid complexity due to distributed generation, renewable production penetration, back up generation, interconnection, demand side management, network congestions and ancillary services will make the future grid operation different from the current one.

The majority of the large transmission and distribution utilities have decided to launch new smart grid prototyping initiatives which once stabilized will be scaled to millions

of connection points. The majority of this initial roll-out is expected to happen between 2010 and 2012.

From a functional stand-point the majority of these early adoptions of smart grids concepts are in the domain of system intelligence and the associated challenges which are related to IT system scalability, basically consisting of applying existing algorithms and processes but in a larger and more distributed manner. It is worth noting that the majority of the main software building blocks exist today but used at scales quite different from the future distribution of sensors in grids. Besides, the software and modeling technologies are improving a lot because of other technologies trends in other industries like airplanes, mobile phone, and military applications.

	Current power grid	Smart Grid
Communication	None or single-way	Two-way
Interoperability	Seldom	Many
Meters Type	Mechanical and digital	Digital with communication device
Operation Management	Home visit	Remote monitoring
Power Supply	Centralization Generation	Centralization Generation and Distributed Generation
Load-flow Control	Limited	Widespread
Reliability	More black out	Adaptive protection
Recovery	Human Interaction	Self-healing
Network Topology	Radicalized	Reticular

Table.2.1 Current power grid vs. Smart Grid

2.5 Key Characteristics of Smart Grid [21]

1) Self-healing

A grid, which is able to rapidly detect, analyze, respond and restore from perturbations. Self-healing is the most important issue in Smart Grid.

Firstly smart grid is equipped with a self-healing ability to response to the threats, material failure and other unexpected problems. A real-time monitoring and reaction can be achieved by using phasor measurement unit (PMU) and other sensors to monitor the parameters such as voltage and current of a particular area. Secondly it monitors the performance of generations and search for any problems that could trigger a disturbance; this will increase the system operator awareness.

A self-healing ability will involve in intelligent communication and monitoring system. Such technology will enable the system to be a self-healing. It has the capability of fault-tolerant that will enable the system to operate properly at the presence of fault i.e. it resists attacks. It accommodates all generation and storage options including plug-in vehicles [7]. It will provide a plug-and-play interconnection to any source of power including renewable energy sources such as wind and solar sources and storages. This is will increase integration and flexibility in power resource mix.

Electricity infrastructure is highly interconnected which makes them suitable for intelligent and self healing technology applications. This can be achieved by using intelligent agents to sense and measure the parameters for each generator and communication with central network, such agents need to be adaptable to the environment in order to improve their performance. Different agents are used in different levels of system; some are used for self-healing, control and others are for operation and management of the system.

2) Empower and incorporate the consumer

The ability to incorporate the consumer equipment and behaviour in the design and operation of the grid

3) Tolerant of Cyber Attack

A grid that mitigates and stands resilient to physical and cyber security attacks

4) Provides power quality needed by 21st century users

A grid that provides a quality of power consistent with consumer and industry needs

5) Accommodates a wide variety of generation options

A grid that accommodates a wide variety of local and regional generation technologies (including green power)

6) Fully enables maturing electricity

Allows competitive markets for those who want them

7) Optimizes assets

A grid that uses IT and monitoring to continually optimize its capital assets while minimizing operations and maintenance costs

2.6 Technologies of the Smart Grid [20]

From a functional stand-point the majority of these early adoptions of smart grids concepts are in the domain of system intelligence and the associated challenges are related to IT System scalability, basically consisting of applying existing algorithms and processes but in a larger and more distributed manner. It is worth noting that the majority of the main software building blocks exist today but used at scales quite different from the future distribution of sensors in grids. Besides, the software and modeling technologies are improving a lot because of other technologies trends in other industries like airplanes, mobile phone, and military applications.

In order to complete the transition that has already started the following new system intelligence functions will in the future be required to approach the Smart grid infrastructure targets. However, it should be recognized that these are only some system-level functions and a full implementation of Smart Grids will also require smart equipment such as Fault-Current Limiters, new protection schemes/algorithms to facilitate increased distributed generation connection some of which are discussed

in this chapter and a massive growth in the use of power electronics, for example, Flexible AC Transmission System (FACTS) etc. and embedded energy storage, even at lower voltage/power levels than those for which they are used today.

General technological development for smart grid equipment and solutions are now widely shared, for example at the European level through the Smart Grid technological platform for the electricity of the future or in the US through Grid wise. Several research and development programs have been formed in recent years with the goal of improving the intelligence of the electric power infrastructure. Several major programs can be identified for example:

- **GROW-DERS:** Grid reliability and operability with distributed generation using transportable storage.
- **INTEGRAL:** achievement of an integrated ICT-platform based distributed control of decentralised energy resources.

These programs, along with other established R&D organizations, are addressing the technical, economic, and policy barriers to creating a smarter grid. This abundance of research has bolstered the confidence of industry stakeholders, who now recognize that transformation of the grid indeed can be accomplished within the next few years.

There are strong drivers to smart grid progress and deployment. Many political bodies, in the US and in Europe, at different levels (EU, countries, regions), perceive smart Grids as a tool that can be leveraged to promote several major policies and tackle several major issues related to environmental impact of electricity industry, security of energy supply and economic efficiency of this market. In Europe there is now an incredible pressure towards renewable use within the energy mix, 20% by 2020. Moreover, as long as the countries don't combine energy savings and very strong heat promotion into buildings, all the pressure will be put on electricity.

Technologies that have been developed for smart grid are mainly concentrated the following three areas.

The first one is integrated communications. This is necessary for smart grid since it's

required for all levels of the system to make the system smarter and more intelligent. It connects components of the system together; this is to make the components aware of each other's performance

The second one is sensing and measurements. These technologies support the system to be faster and more accurate response, such as remote monitoring, data management etc.

The third one is advance control. It monitors essential components and system areas and enables rapid diagnosis at the event of disturbances and provides an accurate solution for each event. The components are made of superconductor. Improved interfaces and decision support amplify human decision-making; promote grid operators and managers into knowledge workers

To develop such a smart grid system that can provide advanced control and optimisation, prediction, monitoring etc. it requires fast and dynamic algorithms that can learn system's behavior; this is where computational intelligence comes in.

2.7 Benefits in Implementing Smart Grid [21]

- It will reduce the congestion cost.
- The probability of blackout will be reduced. It forced outages/interruptions.
- There is also a reduction in restoration time, operations and maintenance due to predictive analytics and self-healing attribute of the grid.
- It will improve ability to supply information for rate cases. There is a visibility of utility operation. Hence, it will reduce the peak demand.
- It will increase integration of distributed generation resources and higher capacity utilization.
- It will increase cyber security and tolerance to cyber attacks.
- It will improve power quality, reliability and system availability and capacity due to improved power flow.
- It will increase capital investment efficiency due to tighter design limits and optimized use of grid asset.

- It will supply more new options for consumers to manage their electricity use. It means it can improve consumer satisfaction.
- It will reduce the carbon emission due to increased asset utilization.

2.8 Key Challenges of Smart Grid (the future) in UK [10]

- Strengthening the grid – ensuring that there is sufficient transmission capacity to interconnect energy resources, especially renewable resources.
- Moving offshore – developing the most efficient connections for offshore wind farms and for other marine technologies.
- Developing decentralised architectures – enabling smaller scale electricity supply systems to operate harmoniously with the total system.
- Communications – delivering the communications infrastructure to allow potentially millions of parties to operate and trade in the single market.
- Active demand side – enabling all consumers, with or without their own generation, to play an active role in the operation of the system.
- Integrating intermittent generation – finding the best ways of integrating intermittent generation including residential micro generation.
- Enhanced intelligence of generation, demand and most notably in the grid.
- Capturing the benefits of distributed generation and storage.
- Preparing for electric vehicles – whereas smart grids must accommodate the needs of all consumers, electric vehicles are particularly emphasised and possible massive deployment in the next years, which would yield a major challenge.

2.9 Implementation Sequence and Steps to Smart Grid

The four major objectives of smart grid development are to achieve safe and stable operation of power grid, to enable distributed generation with great efficiency, to improve the utilization of the grid's assets, and to provide power for consumers with higher efficiency, reliability and quality. [11]

These objectives can technically reach through the smart grid with close cooperation of the AMI (Advanced Metering Infrastructure), ADO (Advanced Distribution Operations), ATO (Advanced Transmission Operations) and AAM (Advanced Asset Management). The costs and benefits of smart grid development are depending on its implementation sequence, and thus the first step of smart grid development is generally AMI while ADO is proposed to test in areas of high power quality requirement. It is suggested that even at the planning stage of a urban power grid, its long-term development should be taken into account as the flexible and reconfigurable distribution network topology and the integrated energy and communication system architecture are the foundation of any smart grid. [11]

There are ten steps to smart grid in UK [10]:

- Provide a user-centric approach and allow new services to enter into the market
- Establish innovation as an economical driver for the electricity networks renewal
- Maintain security of supply, ensure integration and interoperability
- Provide accessibility to a liberalised market and foster competition
- Enable distributed generation and use of renewable energy resources
- Ensure best use of central generation
- Consider appropriately the impact of environmental limitations
- Enable demand side participation
- Inform the political and regulatory aspects
- Consider the societal aspects

2.10 Conclusion

Streamlining and simplification of existing permission procedures and standardisation of the grid codes for the connection of distributed generation is required to encourage greater distributed resources integration. The standardization in the connection requirements of distributed generation, particularly of the protection equipment and settings criteria, will be very positive for the development of the distributed generation, especially in highly interconnected networks to avoid nuisance tripping and obtain more generation availability and so network stability. Also, more intelligent protection is required to overcome some of the protection co-ordination and sensitivity problems with lower fault current and system stability and network capacity concerns with higher integration of distributed generation, especially if controlled islands are allowed and for full converter wind turbine generators which only provide a small contribution to the fault level. Standardised communications infrastructure will be important to encourage some of these intelligent adaptive and wide area protection schemes

Sensing and communication technologies, for example, smart meters are essential to support the development, integration and deployment of flexible, safe, reliable and efficient power distribution management systems. The design, control, management and optimization of these new distributed energy resources and technologies, and their integration into existing energy distribution networks, pose significant technological challenges to ensure their reliability and safety, and to improve and maximize their cost competitiveness.

The future of power transmission and distribution grids is expected to involve an increasing level of intelligence and integration of new information in every aspect of the electricity system, from demand-side devices to wide-scale distributed generation to a variety of energy markets. Price awareness and sensitivity are possible shared between energy suppliers and customers, creating a sophisticated real-time energy market.

Chapter 3

Impact of Smart Metering on Energy Efficiency

3.1 Introduction

As an important part of Smart Grid, smart metering attracts more and more attention all over the world. It is the way for energy consumer to sense the benefit of smart grid directly. Facing the great demand of smart metering, governments and company are busy with establishing policies and standards for smart metering deployment. Smart metering is obtaining many benefits in a lot of aspects. Many smart metering projects are going on many countries, such as UK, Italy, the USA and other countries. Some planning studies list in this chapter show that smart metering is technically feasible. Many benefits are available, especially on improving the energy efficiency. The future smart metering system will rely on policies and governmental fiscal stimuli. However cyber security requirement will be an issue. Smart metering deserves a big attention.

3.2 Smart Metering

AS technologies this day developing fast, more and more problems occurs in power utilizations, such as:

- High cost energy consumption.
- Lack of equitable collocation of multi-energy-resources.
- Low fault detecting speed.
- Carbon pollution.

Facing these problems, smart grid, a topic recently attracted much attention, is one of the best choice to improve the situation. And smart metering, which is an important part of smart grid, is the closest way for energy user to be affected by the advantage of smart grid technology.

Smart meter is one of the applications of the smart metering system. Smart meter is a sensor and a communication device.

In simple terms, smart metering is the combination of energy metering and intelligence. Though the functions of different smart metering products may not completely identical, several basic abilities are contained:

- Multi-energy meters readings. E.g. electricity, water, gas.
- Real-time information of energy used and price of energy.
- Possibility to read meters remotely and locally.
- Possibility of auto fault detection instead of sending to an engineer [22].

With these intelligent functions, energy users could revise their energy consumption way to achieve cheaper bills. Fig.3.1 reveals the relationship between smart metering and energy consumption.

As a part of smart grid technology, smart metering expands electricity and gas meters. Instead of the meter readings and bill-estimation, the data of the amount of electricity and gas could be collected real-time and accuracy for customers and source suppliers. Customers will benefit from this application on leaning how much energy they used at once and choice of optimal energy consumption could be made. In the application, a communication system will be installed so that the suppliers and the customers could both have the real-time information [23]. A simple relationship of smart metering is shown in Fig.3.1.

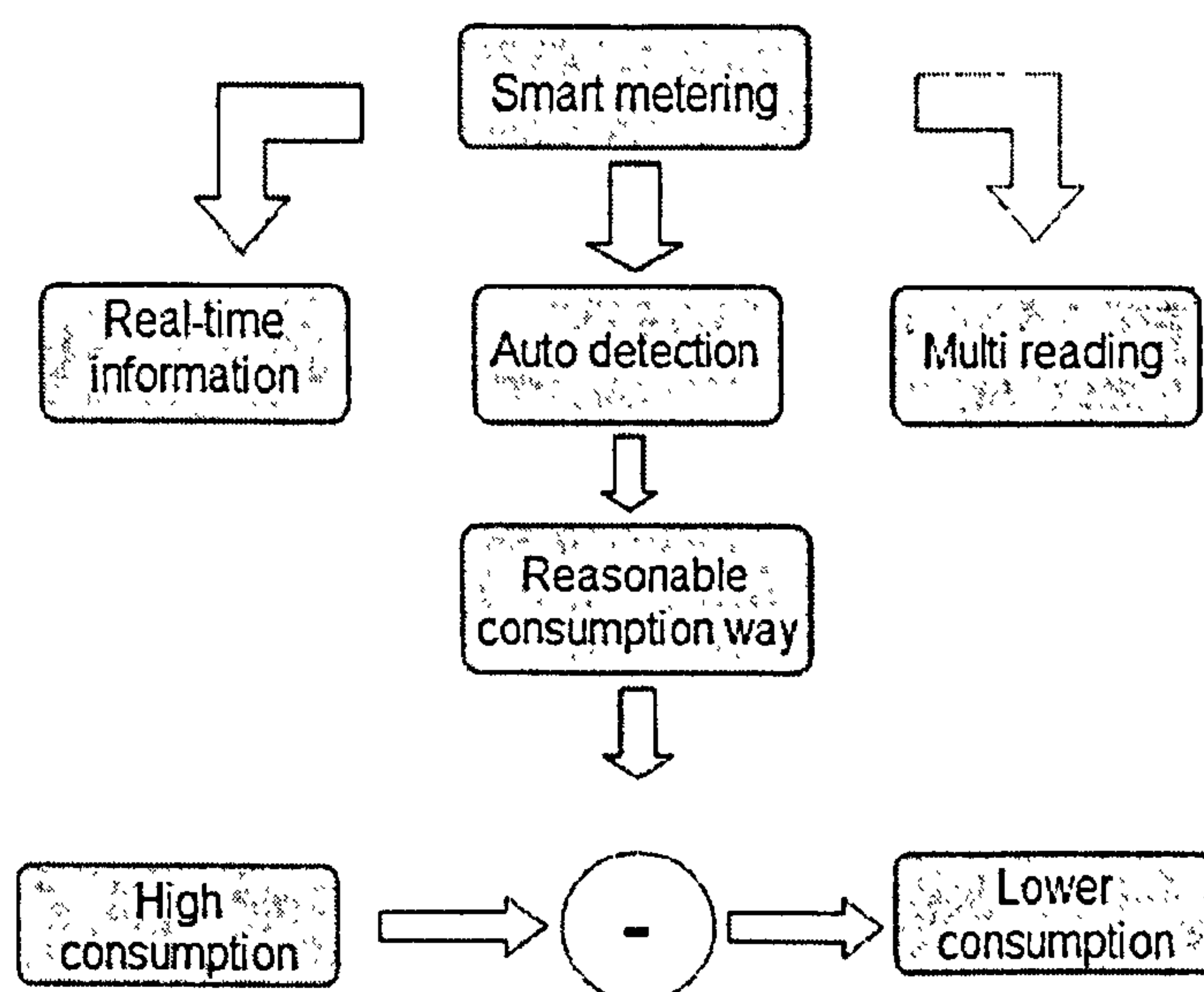

Fig.3.1 Structure of Smart Metering

The most important application of smart metering system is smart meter. Smart meter

is fundamentally different from ordinary meters. It can provide a real-time, accurate, record of the gas and electricity you are using, different times and different costs.

Smart meters, which have a visual display, allow people to see clearly how much electricity and gas they are using and send the data to energy firms automatically.

Smart metering has a huge potential benefits. In the UK, there is no longer self-sufficient energy and North Sea oil and gas are depleting. Smart meters need to play a very important role in reducing the energy consumption. [24].

3.3 Standard and Policy of Smart Metering

As a result of introducing new technologies into metering and different understanding of smart metering, the application of this project appears to be multi-standard and incompatible. So setting up standards and limitation become one of the urgent affairs before used.

No matter which standards or policies, the establisher ought to include the consideration of basic abilities of smart metering, such as a two-way communication between customers and energy providers, display of a flexible price and consumption details. Other than the basic demands, factors considered could be agile.

Until now, different standards and policies have been established by countries, organization and companies, which are basing on the specific conditions and situations. This section provides a brief introduction of some smart metering standards and policies.

3.3.1 Standard and Policy in EU

The European Commission has made an investiture of the standardization requirement to CEN/CENELEC/ETSI, the main European Standard Organisations, for a structure of utility meters enabling interoperability and to improve the awareness of customers of low energy consumption. CEN/CENELEC/ETSI has established an organization, Smart Meter – Co-ordination Group (SM-CG), which constructed and cooperated with several technical committees, e.g. British Standard Institution. [25]

The SM-CG has listed suggested additional functionalities on Smart Metering. [26]

- 1) Remote provision of metering data and related information to the supplier or other designated market organisations.
- 2) Two-way communications between the meter and the supplier or other designated market organisations.
- 3) Support for flexible tariffs.
- 4) Remote disablement and enablement of supply
- 5) Provision of information to home and network.
- 6) Load management capability.
- 7) Exported electricity measurement.
- 8) Capacity to communicate with a measurement device within a micro-generator.

Some other European Committees are listed in Table.3.1

Reference No.	Name
CEN/TC 92	Water meters
CEN/TC 171	Heat cost allocation
CEN/TC 176	Heat meters
CEN/TC 237	Gas meters
CEN/TC 318	Hydromotry
CEN/WS	DPP
CLC/TC	8X system aspects of electrical energy supply

Table.3.1 EU committee on Smart Metering [26]

3.3.2 Standard and Policy in Australia

In 2007, Ministerial Council on Energy's (MCE) in Australia has make up a decision to set up minimum functionalities for Smart Meters. Also, MCE agrees to establish the minimum functionality in the National Electricity Rules and relevant regulatory arrangement in the other jurisdictions. A cost-benefit analysis for each function has been applied and based on this analysis; an initial set of functions is added into the national minimum functionality, including [27]:

- Remotely read interval metering, with the meter capable of daily reads;

- Quality of supply and outage detection to improve consumer supply services.
- Ability to control connection and disconnection remotely and apply supply capacity limits to manage emergency situations.
- Import and export metering to support distributed generation such as solar PV.
- Ability to manage load through a dedicated circuit, to support existing off-peak arrangements.
- Supporting management functions such as data security tamper detections, remote configuration, remote upgrade and plug-and play installation

At the same time, MCE recognises that some new functions will request review of existing jurisdictional consumer protection and safety arrangements, like remote connect/disconnect and supply capacity limits.

Table.3.2 has shown a small part of The National Minimum Functionality for Smart Meters. Particular details could be looked up from reference [27].

Functional	Description	Recommendation	MCE decision
Power factor – three phase	Half-hour reactive interval energy measurement and recording on three phase meters	Agree-based on the argument put by consultants of minimal costs.	Support inclusion
Power factor – single phase	Half-hour reactive interval energy measurement and recording on single phase meters	Agree-based on the argument put by consultants of minimal costs.	Do not support inclusion

Table.3.2 MCE Response on Initial Functions to Be Included in the National Minimum Functionality for Smart Meters [27]

3.3.3 Standard and Policy in China

As one of the largest energy consuming countries, application of smart metering, which is an effective way of economizing energy usage, could reduce the

consumption much more than other countries.

From Sep.2008, the STATE GRID Corporation of China had start-up programs on standardization of smart metering. Until Nov, 2nd, 2009, in the conference “The China Energy and Environment Summit”, Engineer Xue Bin Hu said the standards of smart metering would be coming in early of 2010. Up to 13 organizations had attended to the work of standardization, including China Electric Power Research Institute and several province grid companies. These coming standards are divided into 12 series, including:

- Smart meters functionalities standards
- 3-Phase smart metering types
- 0.2S-level 3-Phase smart meters technologies.

Smart meters information communication and safety technologies. [28]

Ref. No.	Name
Q/GDW354	2009 Smart meters functionalities standards
Q/GDW357	20090.2S-level 3-Phase smart meters technologies
Q/GDW363	2009 level 1 3-Phase smart meters technologies
Q/GDW364	2009single-phase smart meters technologies
Q/GDW365	2009 Smart meters information communication and safety technologies

Table.3.3 Standards of Smart Meters in China [28]

3.3.4 Standards from companies

As smart metering is a program combining other technologies with electricity grid, companies and experts being professional in their area are invited to contribute their majors. So in different technical areas related to smart metering, companies also set up the standards of technique specific used in smart metering.

ZigBee Alliance, constructed by a group of companies, has made out a wireless network standard, named ZigBee standard. A structure of ZigBee network was shown in Fig.9.2 [29]. This standard is based on IEEE 802.15.4, with the feature of low data rate, low power consumption, low complexity, and long battery life and so on. In late 2009, the European Smart Metering Industry Group (ESMIG), cooperating with ZigBee Alliance, is working on the definition of interoperable communications standards for smart metering in EU. ZigBee will be an industrial standard for in-the-home wireless links to smart meters in EU [30]. IEEE 802.15.4 is a standard which specifies the physical layer and media access control for low-rate wireless personal area networks. It is maintained by the IEEE 802.15 working group. IEEE standard 802.15.4 intends to offer the fundamental lower network layers of a type of wireless personal area network (WPAN) which focuses on low-cost, low-speed ubiquitous communication between devices (in contrast with other, more end user-oriented approaches, such as Wi-Fi). The emphasis is on very low cost communication of nearby devices with little to no underlying infrastructure, intending to exploit this to lower power consumption even more.[105]

In Dec. 2008 the International Organisation for Standardisation (ISO) and the International Electrotechnical Commission (IEC) approved the LonWorks technology platform from Echelon Corporation to be a global standard. The Lon Local Operating System (LonWork) is created by Echelon in 1991 for networking devices over media. Automation of multi-area and power system is the mainly usage of this technology. [31]

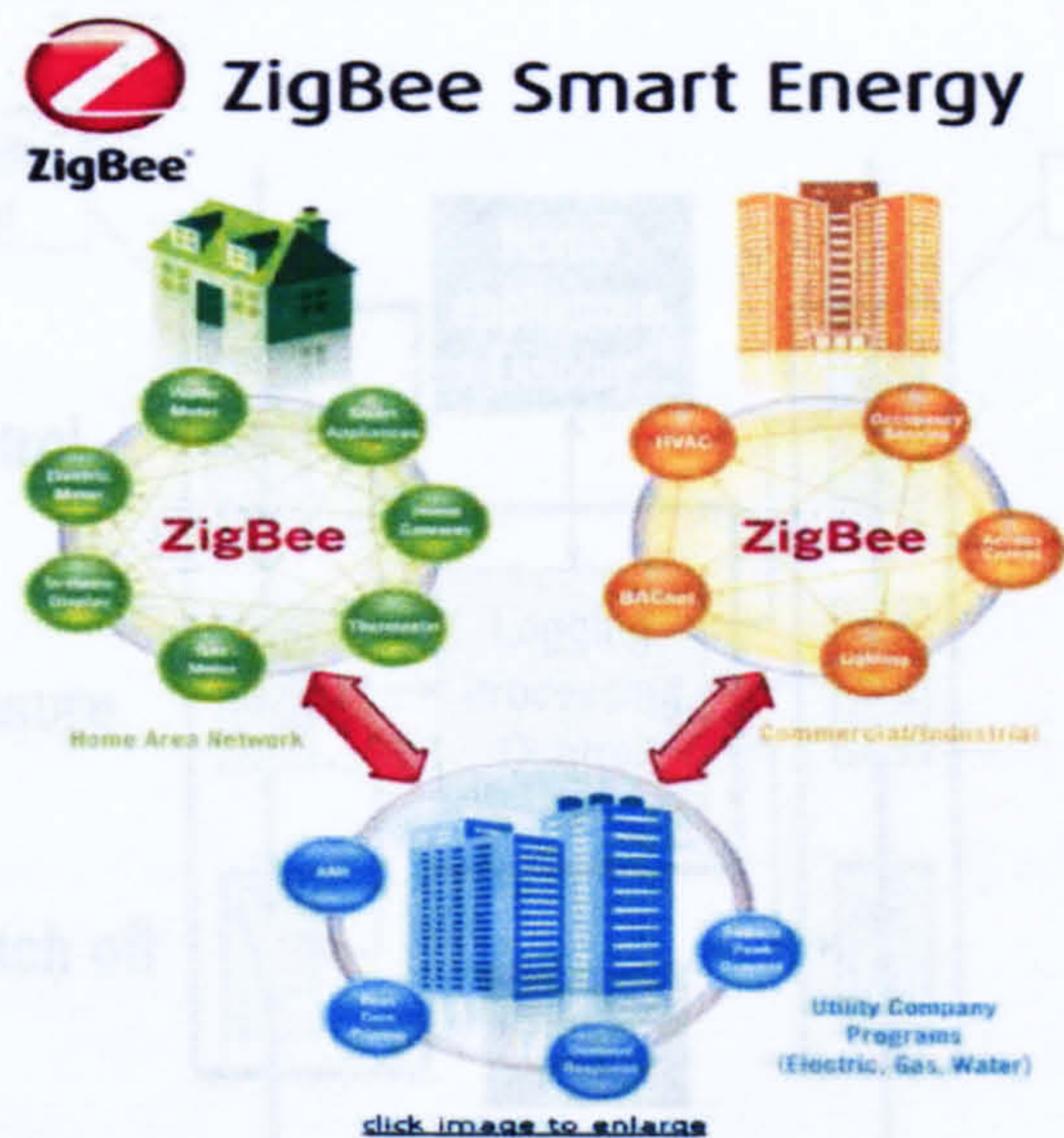

Fig.3.2 Structure of Zigbee Network [29]

3.4 Smart Metering Impact on Energy Efficiency

Nowadays, more and more people are encouraged to adopt Renewable Energy in order to reduce in greenhouse gas emission, and also the very important issue of climate change. And the smart meter provide knowledge, increase awareness and affect customers' behavior and attitude in using renewable energy. In the future, renewable energy is the trend to reduce the carbon emission and gas emission from the power generation. Although, it may not be cheap from the generation cost at the moment but customer can try our best to reduce the impact due to climate change. Hence, if every household can use electricity and gas efficiently, there is a need to minimize power generation as well [32].

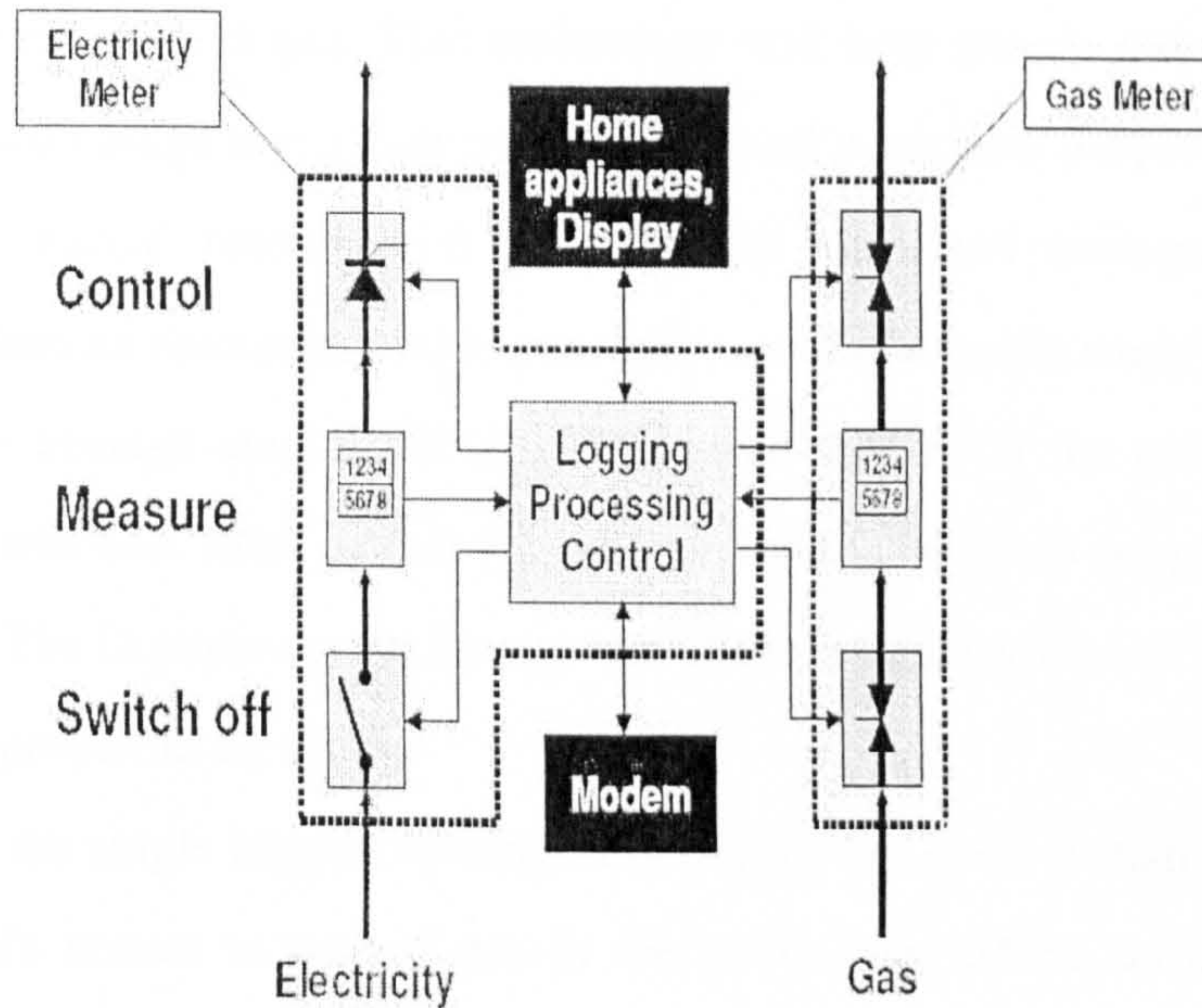

Fig.3.3 Overview of a Typical Smart Meter [34]

3.5 Smart Metering Case Study Worldwide

Most countries of the world are paying more and more attention in smart metering projects. This section gives a survey of many countries' plan in smart metering and smart grid. Some implementation examples are given such as UK, China, Italy, and USA and so on.

3.5.1 Imminent implementation of smart metering in UK

Recently, UK energy smart meter has been roll-out. The government had announced every household will install the smart meter in the UK by 2020. The first provider of business and consumer smart meters in the UK as standard was First Utility.

"Smart meters will put the power in people's hands, enabling us all to control how much energy we use, cut emissions and cut bills," said Energy and Climate Change Minister Lord Hunt.

Energy supplier will be in charge of the roll-out of smart meters rather than distribution networks. It will cost 340 pounds per household. However, it will be recoup the money from the saving of the high bills.

This plan shows smart meters enable customers to reach a clear understanding of how

much use electricity and gas. This technology will help people reduce waste, pay more attention on usage to cut their energy bills. And it can help people to realize how to reuse the wasted resources. It will achieve maximum savings and rational utilization of human resources, and increase the use of renewable energy.

Currently, the average annual bill in UK is more than £800 for gas and £445 for electricity. It will cost £8bn pounds for the plan, and it will help people save at least £28 per year. The Department for Energy and Climate Change hope 47 million meters in 26 million properties by 2020.

"This will be the single biggest revolution in energy use since British Gas converted all the nation's homes to natural gas in the 1970s."said Mark Daeche, of energy company First Utility.

Energy providers will responsible for fitting the meters what the amounts to the huge programmed of the work since British Gas changed appliances in 17 million homes to natural gas back in the 1970s.

Industry sources in UK show that the £7bn cost amounts to around £15 per household per year between 2010 and 2020. However, £10 of that will be accounted for in cost savings by the suppliers. And the average consumer is possible to save 2% to 3% of the energy use per year, and will cut £25 to £35 off their bills.

In total, customers could be better to cut off the bills more than £20 a year. The government says that they could save around 2% of the total energy use, which would cut £100m from our bills by 2020.

That means it could reduce CO₂ emissions by 2.6m tones.

In the future the smart meter will need to process a variety of emergency situations, recycling of various resources and effective reuse of resources [33].

3.5.2 China smart meter and smart grid project

China has started a lot projects related to smart grid, which will change the whole country, generates and uses energy. All the projects will improve the efficiency and security of the whole power grid.

“A smart grid is an inevitable choice for China to address issues in its power industry

and develop a lower-carbon economy,” said Jiao Jian, an analyst at SYWG Research and Consulting. SYWG is the research arm of the Chinese brokerage Shenyin & Wanguo Securities

All the proposals of the smart grid will increase Chinese investment in the power industry. “For years the sector has suffered from lacklustre funding that resulting in blackouts and the infamous infrastructure collapse during the snow storms in 2008.”[34]

There are 1.18 million kilometers of old transmission lines that carry 3 million gigawatts of electricity in Chinese entire power grid. Around 7% of the 3 million gigawatts are lost from power transmission. But it is expected to double the power demands by the year 2020.

Nowadays, most of the china’s power is generated by dirty coal plants. It is achieved around 70% of the total amounts. The Chinese government has begun to clean up the energy resources. They want to achieve 15% of the total power supply by using renewable power generation in 2020.

Most of the proposals of the smart grid need the integration of the renewable power resources such as wind and solar. And GE will collaborate with State Grid on their smart grid development.

China uses UHV (ultra-high voltage) lines which can afford efficient power flow without big loss. This kind of transmission system is very useful in such big country as where resources are rich but unevenly distributed. China has started operating a 640-kilometre UHV lines across the central part of china in January 2009. State Grid satisfies with the line performance and now they are installing another two more lines, which will carry power across the 2000 kilometers. State Grid expected investment of the UHV lines can be effective and will spend 300 billion Yuan (\$43.94 billion) on the effort by 2012 [34].

3.5.3 Smart metering projects in Italy

In the world of Smart Metering applications until now, smart metering projects in Italy is definitely a splendid point, with the largest deployment in the world

undertaken by ENEL SpA in this field. As a result, the Italian becomes one of the first beneficial owners from new technologies on energy economy.

Before this project started to deploy in 2001, Italy was suffered from a variety factors bringing about high cost in energy affairs. Prices of electricity are averagely higher in Italy than other European countries, partly due to near 70% Italian consume electricity from hydrocarbons while a similar percentage from nuclear power and other resources in other Europe. Number of fraud and bad debt is another reason for considering. Also, improving data to achieve a better management on generation and prevention blackout is an important business need driving this deployment as well [35].

In 2001, ENEL drew up a 5-year plan on smart metering to its entire customer base, which covers near 40 million homes and businesses. New meters are own designed with multi abilities integrated such as advanced power measurement and management capabilities, software-controllable disconnect switch. These meters are based on standards-based power line technology from Echelon Corporation, which will automatically reveal the time-of-day pricing to customers and send readings to a central office [36].

Abilities integrated in New Meters
Bi-directional communications
Advanced power measurement and management capabilities
Software-controllable disconnect switch.
An all solid-state design.

Table.3.4 Abilities integrated in Smart meters

By 2006 ENEL had invested \$3 billion in the whole smart metering deployment, comparing to its ‘harvest’ of cost savings up to \$750 million from new technology annually. These savings include automatically collecting customer data and manage its energy network remotely, instead of paying for a costly technician. To Italian users, the ability of real-time electricity pricing of the new meter could form a logical energy consuming habits and concretely reduce the family cost in energy consumption.

Smart metering in Italy has given a good experiment to the world. The ENEL's Gallo recommended that corporations need to deploy their technology as quickly as possible. A whirlwind program will help achieve a fast return on investment. It also suggested corporations to make sure their consumers to understand the whole face and the advantages of the programs [36].

3.5.4 Smart metering implementation in United States

The main driver for introducing Smart metering system in USA, especially in California, is to improve the power quality and electricity supply. California has a summer peak demand for power during about 50-100 hours per year. Hence, more and more air conditioners are used. The main energy supply of California sees demand response and expects decrease this peak. All three main California utilities developed their own projects to implement the smart metering system or automatic metering infrastructure (AMI) systems at all customers. Deployment plans need to install all smart meters and communications infrastructure by 2012 or 2013 [22].

On July 20, 2006, California's energy agency approved a project to roll out conventional meters with communications co-processor electronics, which is Smart meter, to 9 million household customers in the Northern California of PG&E (Pacific Gas and Electric Company). Those meters can record and report electricity and gas consumption on every hour basis. This action can help PG&E to set pricing, which changes by seasons and time of the day. And the users also can shift energy use to off-peak time. The peak pricing program will full roll out in next five years [37].

Pacific Gas and Electric Companies \$1.7 billion Smart Meter proposal received unanimous approval by the California Public Utilities Commission, which allows the utility to move forward with a major investment in new smart meters designed to provide a wide range of benefits to household customers while increasing operational efficiencies and energy saving at the utility [38].

“PG&E's installation of 9.3 million Smart Meter devices for its 5.1 million electricity and 4.2 million gas customers is scheduled to begin in Bakersfield this autumn and finish system-wide in 2011.”[38]

"PG&E's Smart Meter program is one of the cornerstones of a sweeping effort to take a dramatic leap forward in the way we deliver service to our customers" said Tom King, president and CEO of Pacific Gas and Electric Company. Customers can obtain more and better information from the smart meter and make cost-saving of using energy. The PG&E also can receive message from their customer and give rapid response to restore service, otherwise customer can phone the company call centers. When the smart metering system is installed, customers will not need to make a special appointment with meter readers' access to reach your meter. Customer also can check their daily information about energy use online, and then they can make better decision. Because the smart meter can record energy usage every hour, customer can voluntarily adjust their usage depends on different energy prices that vary by season and time of the day by shifting their energy use from peak hour to off-peak hour [38].

"A key feature of Smart Meter technology is the ability to reduce peak load on the very hottest days by providing financial incentives to customers who voluntarily shift electricity usage away from critical peaks, which will reduce PG&Es need to purchase power to meet demand at the most critical times, help avoid strain on the power grid, and help reduce reliance on fossil-fuel generation." To achieve those benefits, the CUPC (California Public Utilities Commission) approved PG&E proposal to provide customer a Critical Peak Pricing choice. The smart meter device is almost identical in size and out looking to the existing electric meter. The gas smart meter module is a tiny part which can be installed in the existing gas meter. Many of companies in the USA are ready to employ the smart meters. However, PG&E's program is the largest one in the United States. PG&Es investment to develop the new smart meter technology is estimated to be \$1.74 billion, consisting of \$1.41 billion of capital and an estimated expense of \$330 million. PG&E projects that these investments will be offset through energy saving achieved by using the new smart meters. [38]

The largest municipal utility in the USA, the Los Angeles Department of Water and Power (LADWP), has chosen to develop its AMI serving their own customers. LADWP has bought 9000 already. Then all the customers in utilities can realize their

daily energy use from the smart meters, thus creating potential for decreasing their energy use, and contributing to global energy conservation. Austin Energy, the nation's ninth largest community-owned electric utility. There are around 400,000 electricity customers in Austin, Texas, has begun to deploy a two-way RF mesh network and around 260,000 residential smart meters in 2008. And more than 165,000 smart meters have been installed by spring 2009 [37].

3.5.5 Smart metering implementation in other countries

Including the countries introduced above, smart metering is still fascinating other participants by its pre-eminent feature in energy affairs. In Australia, Victoria State, a program named Advanced Metering Infrastructure is being deployed to help Victorian to manage their energy consumption and reduce issue of Carbon. Nearly 2.2 million homes and 300,000 businesses benefit from this largest energy infrastructure reformation in the state's history. Mature features are included in AMI, such as a two-way communication between power corporations and the electricity meter at home; permission on accessing accurate electricity pricing reads every 30 minutes, and so on. The decision of Victoria Government on rolling out smart metering followed an extensive cost-benefit study and a National Cost Benefit Analysis. These studies reveal that the rolling out of smart metering Victoria could receive net benefits up to \$700 million over the coming two decades. Also by replacing the existing electro-mechanical accumulation meters, Victorian electricity users are able to acquire less than 160 MWh every year. [39]

In addition, the Department of Primary Industries has held a series of forums to collect a wide range of ideas and views on AMI. Table.3.5 is a part of these forums.

	Time	Descriptions
Stakeholder Forum 1:	May 2006	Outlined the Victorian Government's decision to commence the AMI project and approach
Stakeholder Forum 2:	Aug 2006	Updated stakeholders on progress, and initial broad-based consultation on draft of AMI functionality
Stakeholder Forum 3:	Apr 2007	Provided a progress update and overview of proposed legislative and regulatory framework
Stakeholder Forum 4:	Dec 2007	Marked the end of the establishment phase and hand-over to industry for the implementation phase

Table.3.5 Part of schedule of Series of FORUMS [39]

As the largest neighbor of Australia in Oceania, New Zealand started its smart metering program by late 2006. Companies are rolling out their smart metering plan to their customers one after another. But in June 2009, the New Zealand parliament was presented a report, criticizing the deficiency of smartness of the 150,000 smart meters installed. Commenter said that the questionable meters were insufficient of basic real-time monitoring functions. Also the meters lack a microchip at the initial installation, which helps meters to communicate with other devices. Other than the problems above, as no sign for standard, installing types vary differently between companies. It seems that additional cost should be applied for retrofitting.

Back to Europe, Electricité Réseau Distribution France (ERDF) has emitted a replacing program of smart meters covering 35 million electricity consumers in France, starting with a pilot trail of 300,000 meters. Atos Origin is chosen as a consortium manager and the architect for information system, named Automated Meter Management (AMM) system. [40]

3.6 Conclusion

This chapter gives a comprehensive review on the benefit of smart metering in power network such as energy efficiency improvement and reduction in greenhouse gas emission. Naturally, this helps readers to minimize the time for knowledge transfer in a significant amount. The benefit is having smart meters to enhance assets management has been highlighted. Numerous case studies worldwide have been given. International engineering practices and policy have been discussed.

A detailed survey on smart metering application has been carried out in standard, practices and case study worldwide. It concludes that smart metering has a huge potential in improving energy efficiency and allow energy trading down to customer level. However, for this to happen, it is essential to have a very advanced communication infrastructure.

Chapter 4

Signal Processing for Power Quality Analysis

4.1 Introduction

In recent years, power quality problems have drawn much attention due to increasing demand of reliable and stable operations of power systems. Modern system use sensors named Phasor Measurement Units (PMU) distributed throughout their network to monitor power quality and in some cases respond automatically to them. Using smart grid features of rapid sensing and automated self healing of anomalies in the network promises to bring higher quality power and less downtime while simultaneously supporting power from intermittent power sources and distributed generation, which would if unchecked degrade power quality. [106]

To achieve those smart technologies for smart Grid which will operate in extreme complex and dynamic system, it's necessary to use computational intelligence which provides various solutions and algorithms for such problems. Computational Intelligence is the study of adaptive mechanism to enable or facilitate intelligent behavior in complex system. It's based on algorithms and intelligent systems such as wavelet applications, artificial neural network, genetic algorithm fuzzy systems, evolutionary computation, swarm intelligence, bacteria foraging, ant colony optimization and immune systems. This chapter focuses on wavelet application for power quality analysis.

To achieve fully smart grid system it is necessary to overcome these very complex and nonlinear system and improving power quality.

Power quality is the set of limits of electrical properties that allows power systems to function in their intended manner without significant loss of performance. Power quality is used to describe electric power that drives an electrical load and the load's ability to function properly with that electric power. Without good power quality, an electrical device or load may malfunction or not operate at all. [106]

The wide spread use of power electronic equipment in smart grid causes serious current harmonics in electrical power system. Harmonic currents that flow in the electrical power system would cause extra copper loss and immature operation of over current protection devices. Voltage distortion due to harmonic voltage drop in the electrical power distribution system impairs the operation of voltage sensitive equipment. In order to improve the electrical power quality and reduce energy wastage in the smart electrical power distribution system, especially under the deregulated environment, the nature of the harmonics must be identified so that the causes and effects of the harmonics would be studied. Moreover corrective measures cannot be easily implemented without knowing the characteristics of the harmonics existing in the electrical power system. This chapter presents some basic theory of wavelet and wavelet transform.

4.2 History of Wavelets

Fourier theory point out a signal can be expressed by the summation of sinusoidal function or cosine function, which named Fourier Expansion. When the Fourier expansion expresses a signal, we just can derive the frequency resolution exclude time resolution. This means we can obtain all the frequency of the signal, but cannot derive the time of the specific frequency. In order to inherit the advantages of Fourier analysis and overcome the disadvantages simultaneously, the human was looking for a new method.

“Wavelets are mathematical functions that cut up data into different frequency components, and then study each component with a resolution matched to its scale [41].” The wavelets have a lot a benefit which are better than traditional Fourier methods in analyzing physical situations where the signal contains discontinues. Wavelets were developed independently in a lot of fields of science. The wavelet applications are very useful in many fields such as image compression, turbulence, human vision, radar, and earthquake prediction.

In a word, “a wavelet is a waveform of effectively limited duration that has an

average value of zero [41].”

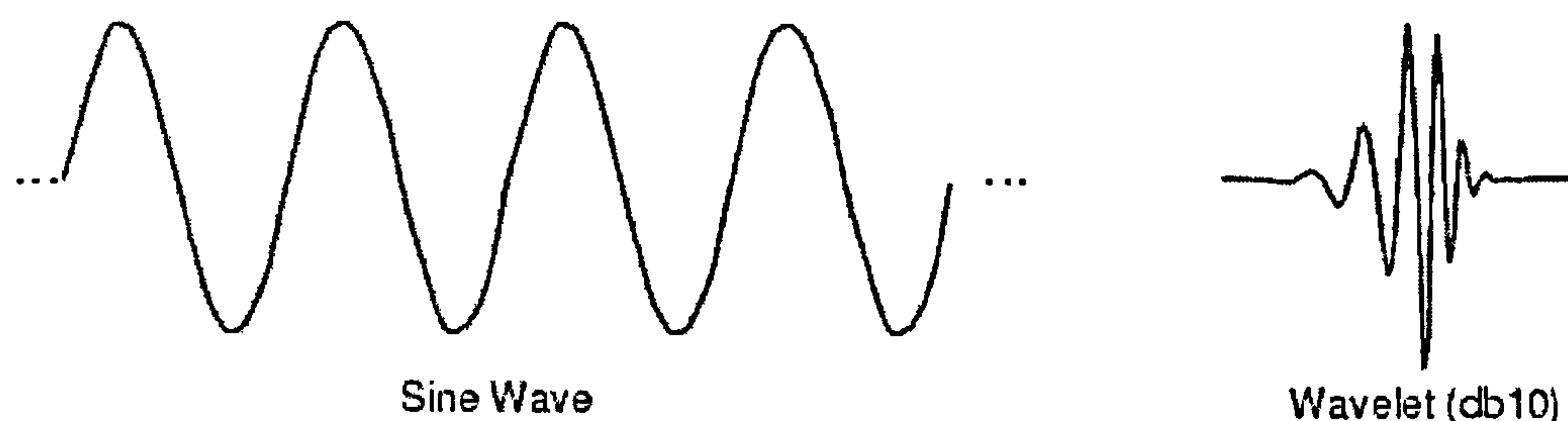

Fig.4.1 Comparing sine wave and wavelet [45]

Alfred Haar found wavelet in 1909. He is the father of the wavelet. It was mentioned in his thesis for his doctoral degree. He was born on October 11, 1885 in Budapest, Hungary. He studied at Gottingen, Germany under Hilbert. His study focused on the orthogonal system of function. And his contributions to wavelets lead to the whole wavelet families named after him. The Haar wavelets are known to be the simplest member of the wavelet family. The concept of wavelet family is easy to understand. They all begin with the scaling function called mother wavelet [42-44].

There is a long time no advances on wavelet mathematics after Haar's contribution until Paul Levy appearance. Paul Levy was born on September 15, 1886 in Paris, France. He has a very good family background on mathematics. His grandfather was a professor of mathematics. His father wrote geometry papers for Ecole Polytechnique, which is a high education school in Paris, France. But Paul Levy did not only make a contribution to mathematical science, but also in chemistry and physics. He studied in Ecole Polytechnique. Then he also taught there until retirement. In Brownian motion, Levy used wavelet to carry out his research. He found that Haar wavelets are better basis than the Fourier basis functions. Unlike the Haar basis function, which can be separated into different intervals, the Fourier basis functions have only one interval. Hence, the Haar wavelets can be used exact model a function. [42-44]

In 1970s, Jean Morlet, who comes from France, had made great contributions to wavelets. Actually, he was the first researcher to use the term “wavelet” to describe

his function. Before 1975, many researchers had taken the idea of windowed Fourier analysis into consideration. This issue allowed people to analyze signal in terms of both time and frequency. Then windowed Fourier analysis was used to study the frequency of a signal window by window. Those windows can make the time discrete or fixed. Different oscillating functions of different frequencies can be looked at in these windows. Jean Morlet also graduated from Ecole Polytechnique. Then he worked for an oil company. He developed his research at that oil company. In 1981, he met a man named Alex Grossman. Morlet and Grossman worked together on an idea that a signal can be transformed to wavelet form and then reconstruct to the original signal without any loss. That means the process is lossless. Their efforts with this issue achieved a complete success. Since that time wavelets deal with both time and frequency, they considered a double integral would be needed to transform wavelet coefficients back into the original signal. But Grossman found that a single integral was all that was needed in 1984. They also found that making a tiny change in the wavelets only cause a small change in the original signal. This is the very important feature of modern wavelets. They made a very important contribution on data compression. [42-44]

In 1980s, Y.Meyer and Stephane Mallet are the main contributors for wavelet. Y.Meyer is a mathematic professor working in France. They met in the USA in 1986. Mallet was very interested in a paper written by Meyer about his orthogonal wavelets. They spent three days on discussing their works have done on wavelets. Multi-resolution analysis was a big progress in the research of wavelets. At that time, the scaling function was first mentioned of wavelets. [42-44]

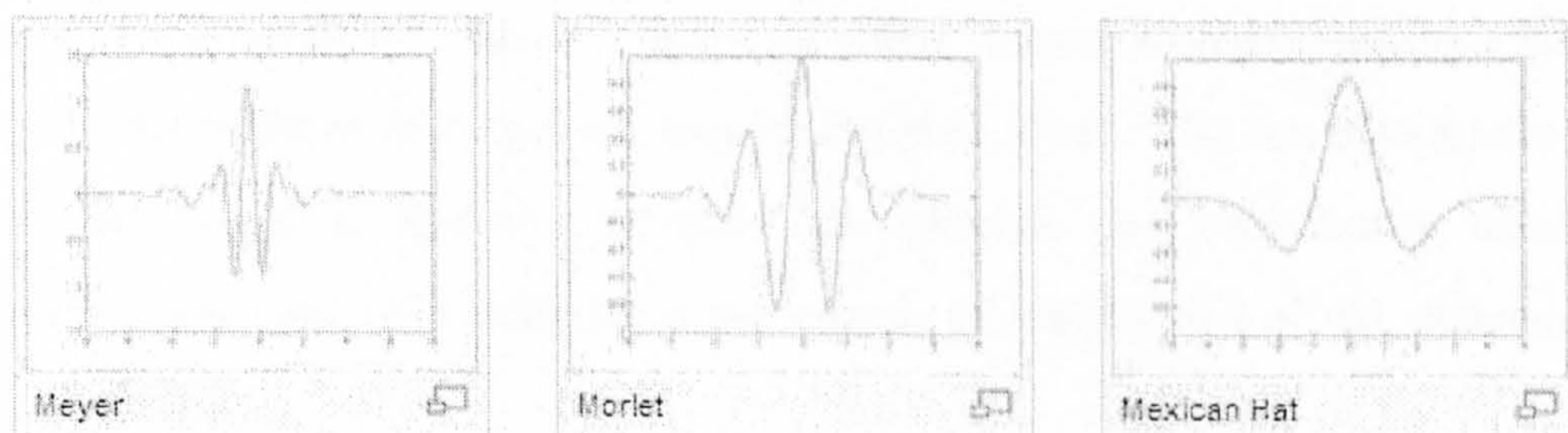

Fig.4.2 Different Mother Wavelet [45]

Furthermore, Multi-resolution analysis led to a simple and recursive filtering algorithm to compute the wavelet decomposition of a function from its finest scale approximation, which named Mallat algorithm.

The latest contributor worth mentioning is Ingrid Daubechies, who is a professor at Princeton University. She was born in Houthalen, Belgium. She obtained her Ph.D in Physics in 1980. Around 1988, Daubechies use multi-resolution analysis to create her own wavelets. These wavelets named the Daubechies Wavelets, which are compact support, orthogonally, regularity and continuity. [42-44]

4.3 Wavelets and Wavelet Transform

In the field of signal processing, wavelet transform (WT) is a new mathematical tool. Wavelet transform is widely used in image processing, data compression and transmission. WT is very familiar with Windowed Fourier Transform. The Short Time Fourier Transform uses a window to section the signal into different portions which can be supposed as stationary, and then Fast Fourier Transform is performed on each section. But this gives poor frequency resolution for non-stationary signals.

Wavelet transform is a method of converting a function into another form. If there is a time signal, the wavelet transform can convert the time function into a time-frequency plane. Wavelet transforms need a wavelet to perform and the wavelet should be localized in time.

Wavelet theory is used to many other subjects. All wavelet transforms may be considered to be forms of time-frequency representation and are, therefore, related to the subject of harmonic analysis. Almost all useful discrete wavelet transforms make use of filter banks containing finite impulse response filters. “The wavelets forming a CWT are subject to Heisenberg's uncertainly principle and, equivalently, discrete wavelet bases may be considered in the context of other forms of the uncertainly principle [46].”

4.3.1 The Continuous Wavelet Transform (CWT)

Mathematically, the process of Fourier analysis is represented by the Fourier transform:

$$F(\omega) = \int_{-\infty}^{\infty} f(t)e^{-j\omega t} dt \quad (4.1)$$

Which is the sum over all time of the signal $f(t)$ multiplied by a complex exponential. The results of the transform are the Fourier coefficients $F(\omega)$, which when multiplied by a sinusoid of frequency ω yield the constituent sinusoidal components of the original signal.[47]

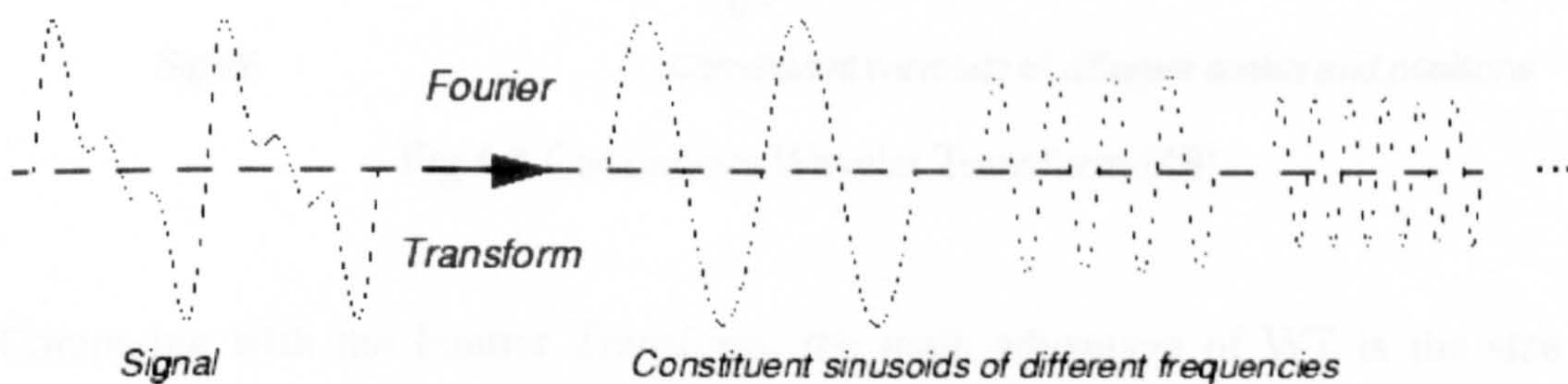

Fig.4.3 Fourier Transform [45]

The continuous wavelet transform of the continuous signal, $f(t)$, is defined as [47]

$$Wf(u,a) = \langle f, \varphi_{u,a} \rangle = \int_{-\infty}^{+\infty} f(t) \frac{1}{\sqrt{a}} \varphi^* \left(\frac{t-u}{a} \right) dt. \quad (4.2)$$

The $\frac{1}{\sqrt{a}}$ in (4.2) is the normalization factor of the wavelet so that if $\varphi(t)$ has a unit length, then its scaled version also has unit length.

At $a=1$ and $u=0$, the wavelet will be the mother wavelet. Wavelets produced by other values of a and u all come from the same mother wavelet. The wavelet coefficients generated by the dilation and translation measures the correlation between the signal and each wavelet function.

There is an inverse wavelet transform, defined as

$$f(t) = \frac{1}{C_g} \int_{-\infty}^{+\infty} \int_{-\infty}^{+\infty} Wf(u, a) \varphi\left(\frac{t-u}{a}\right) \frac{dadu}{a^2} \quad (4.3)$$

The inverse wavelet transform is very important. Because this means the function can be reconstructed from the unique wavelet coefficients. Otherwise, one function can have more than one set coefficients. [48]

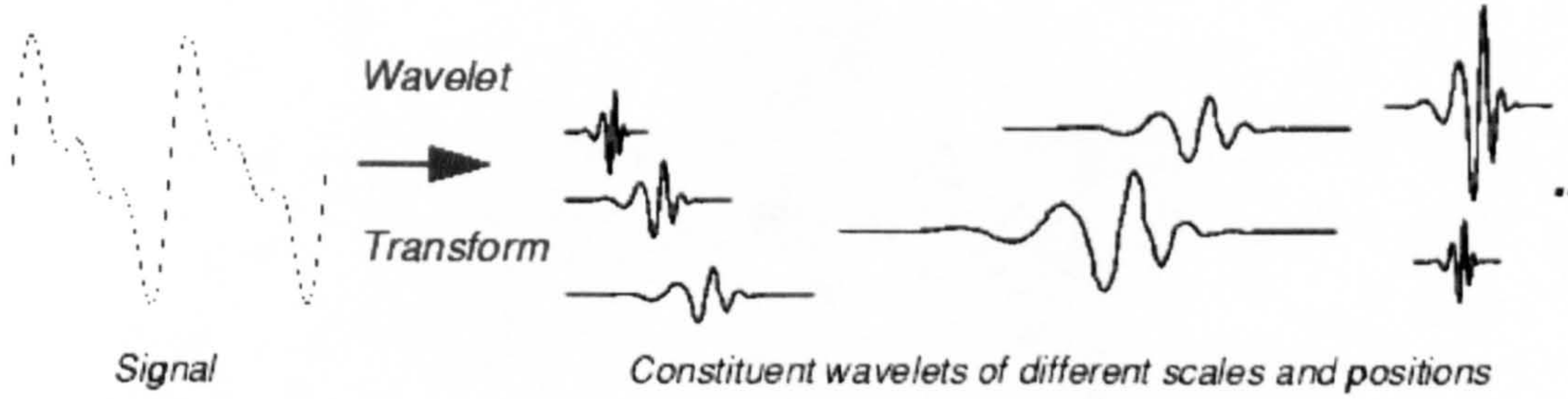

Fig.4.4 Continuous Wavelet Transform [49]

Comparing with the Fourier Transform, the main advantage of WT is the size of analysis window is not constant. The traditional FT cannot simultaneously obtain good localization in both time and frequency resolution. The WT can offer a better performance according to localization.

4.3.2 The Discrete Wavelet Transform (DWT)

By replacing the continuous dilation and translation, the mother wavelet may be dilated and translated discretely selecting $a = a_0^m$ and $u = u_0 a_0^m$ in (4.2), where

a_0 and u_0 are fixed values with $a_0 > 1$ and $u_0 > 0$, $m, n, k \in Z$, and Z is the set positive integers. [50, 51]

Thus the discrete wavelet transform is given by

$$DWT_{\varphi} f(m, n) = \langle f, \varphi_{m,n} \rangle = \int_{-\infty}^{+\infty} f(kT) \varphi_{m,n}^*(t) dt \quad (4.4)$$

DWT provides a decomposition of a signal into sub-bands with a bandwidth that increases linearly with frequency. And DWT is possible to obtain a signal through

wavelet series reconstruction. But the wavelets used for DWT must be real wavelets. This means DWT is not good for phase estimation.

In the wavelet analysis, the two components are called approximations and details. The approximations are the high-scale, low-frequency components of the signal. The details are the low-scale, high-frequency components. The filtering process, at its most basic level show in Fig.4.6

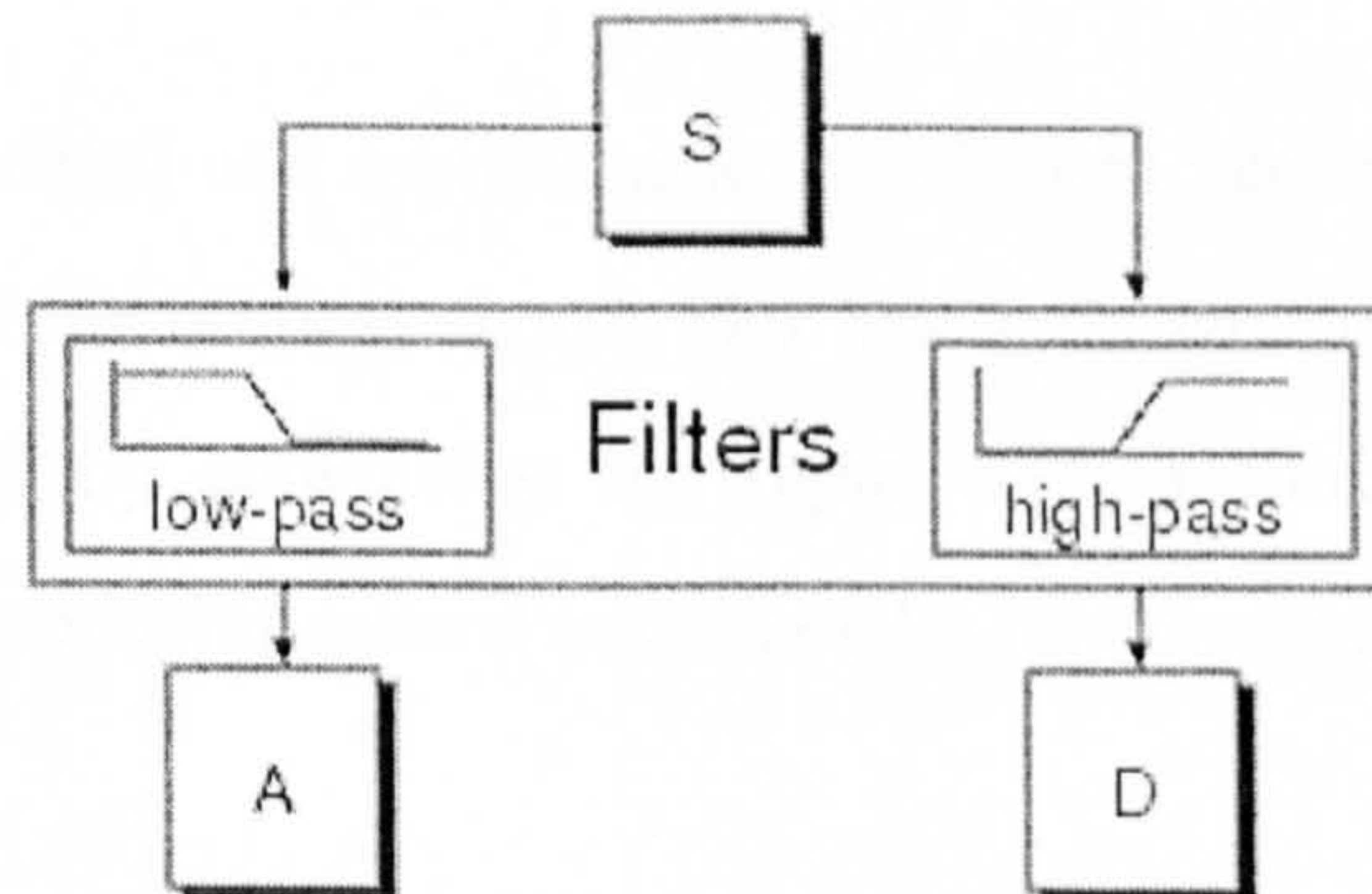

Fig.4.5 Approximations and Details [45]

The original signal, S, gives two filters separate the S into two signals. Unfortunately, if it actually performs this operation on a real digital signal, it will wind up with twice as much data as it started. For example, if the original signal S consists of 2000 samples of data. Then the resulting signals will each have 2000 samples, for a total of 4000.

The signals Approximations and Details are very interesting that is when we get 4000 samples replace of 2000 we had. There is a better method to perform the decomposition using the wavelets. From the process of computation, it can find that it just keep only one point out of two in each of the two 4000-length samples to derive the complete information. This is known as downsampling (as shown in Fig.4.7). What it has produced two sequences called cA and cD. [45]

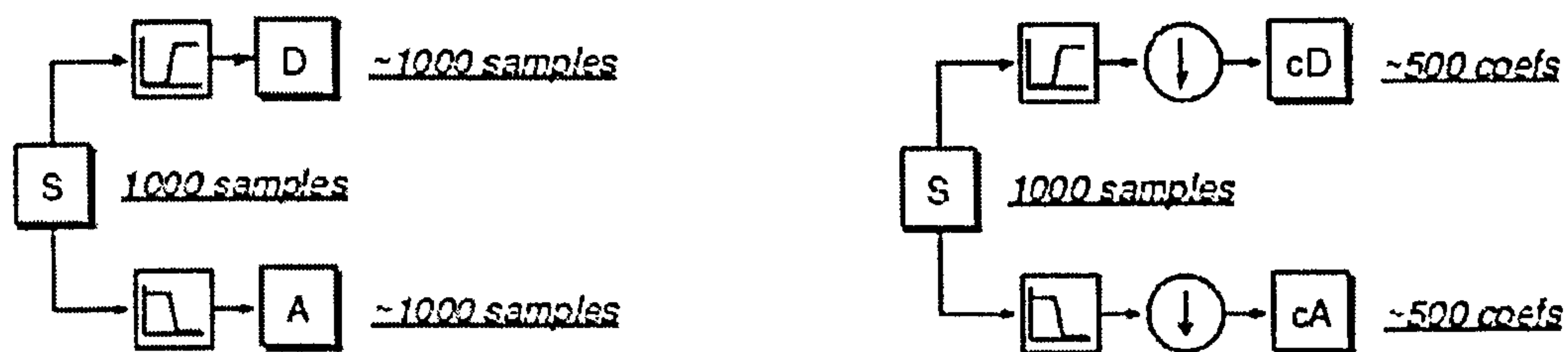

Fig.4.6 Downsampling [45]

The actual lengths of detail and approximation coefficient vectors are slightly more than half the length of the original signal. This has to do with the filtering process, which is implemented by convolving the signal with a filter. The convolution "smears" the signal, introducing several extra samples into the result. [45]

4.4 Wavelet Applications in Power Engineering

The wavelet applications in power engineering are mostly interrelated to power disturbances.

4.4.1 Application of WT for Harmonic Analysis

Many researchers have done and are doing research on transient analysis. As we known, power analysis is based on the FT which just can provide frequency information. And the WT offers the time-frequency analysis. Furthermore, DWT filter bank is a fast and efficient algorithm similar to FFT. As mentioned before, the compressed mother wavelet has a higher frequency in the shorter window, while the lower frequency in a large window. But the best power analysis in transient is the short duration at high frequency, and the harmonics and voltage fluctuations are of low frequency at a longer duration [52-54]. If the harmonics analysis just needs to be considered as a frequency domain, FFT can offer a fast and efficient algorithm to deal with the problem.

With the DWT, one has lost the covariance by dilation and translation of the continuous wavelet transform and the redundancy of the wavelet coefficients, both properties can be very useful for signal analysis and signal processing.

4.4.2 Power Disturbance Network/System Analysis

An approach called Wavelet-Based Transient Analysis (WBTA) has been developed for analysis the power disturbance. This method offers a systematic process to analyze the power system disturbance problems. [55-57]

4.4.3 Power Devices Protection

In the detection transformer inrush current and motor terminal voltage waveform during switching surges in real-time, Wavelet transform has been widely using. Wavelet transform is useful for design a fast relay algorithm. [58-60]

4.4.4 Power Disturbance Identification and Classification

Using the properties of WT and features of the waveform along with a special type of Artificial Neural Network, called the Learning Vector Quantization (LVQ) network, it can extract the important information from a disturbance signal and recognize the type of disturbance. And then it can derive what caused the problem. [61-66]

4.4.5 Power Disturbance Detection and Localization

Power disturbances are caused by transmission line switching, capacitor switching, lightning strikes, faulty conductors and equipment failures. However, harmonic distortion is usually caused by nonlinear loads. Wavelet transform is used to detect and localize these disturbances. [67-71]

4.5 Conclusion

Firstly, this chapter introduces the history and development of wavelet and wavelet transform. From the history and development of the wavelet and wavelet transform, it can be easily seen that wavelet and wavelet transform can give contributions to many areas of sciences and engineering. Then this chapter gives definition of the CWT and DWT comparing with the FT.

Secondly, this chapter discusses the recent applications of wavelet transform in power engineering field. Furthermore, wavelet and wavelet transform have been widely used in many other fields of science and engineering, such as data and image compression, structural vibration studies, electrical power disturbance analysis, acoustical analysis, machine vibration analysis and so on. [72]

Finally it can be easily shown that CWT is most suitable for harmonic analysis.

Chapter 5

Wavelet-Based Algorithm for Harmonic Analysis

5.1 Introduction

The wavelet-based algorithm for harmonic analysis is useful for smart grid because the wide spread use of power electronic equipment in smart grid causes serious current harmonics. Harmonic currents that flow in smart grid would cause extra copper loss and immature operation of over current protection devices. Voltage distortion due to harmonic voltage drop in the smart distribution system impairs the operation of voltage sensitive equipment. In order to improve the electrical power quality and reduce energy wastage in the smart distribution system, especially under the deregulated environment in smart grid, the nature of the harmonics must be identified so that the causes and effects of the harmonics would be studied. Moreover corrective measures cannot be easily implemented without knowing the characteristics of the harmonics existing in the smart grid. The chapter presents an approach based on continuous wavelet transform to identify harmonics in a power signal.

Current harmonics are predominately produced by nonlinear loads. Traditionally the distorting frequency components are in majority integer harmonics, the level of sub-harmonics, integer harmonics, inter-harmonics are however rising and becoming an important concern [73].

Traditionally Discrete Fourier Transform (DFT) implemented by FFT (Fast Fourier Transform) is used to analyze harmonics contents of a power signal. Short-time Fourier Transform and Gabor Transform were developed for estimating time-variant harmonic information. These methods have certain limitations as well [72,74,75,76].

This chapter presents an algorithm based on continuous wavelet transform to identify harmonics in a power signal [77]. The new algorithm is able to identify the frequencies, amplitudes and phase information of all distortion harmonic components, including integer harmonics, sub-harmonics and inter-harmonics.

5.2 Wavelet transform and wavelet

Continuous Wavelet Transform (CWT) is adopted for harmonic analysis because of its ability to identify harmonic frequencies and preserve phase information [47,48,78].

The wavelet transform of a continuous signal, $f(t)$, is defined as [47]

$$Wf(u,a) = \langle f, \varphi_{u,a} \rangle = \int_{-\infty}^{+\infty} f(t) \frac{1}{\sqrt{a}} \varphi^* \left(\frac{t-u}{a} \right) dt. \quad (4.2)$$

where $\varphi^*(t)$ is the complex conjugate of the wavelet function $\varphi(t)$;

a is the dilation parameter (scale) of the wavelet; and

u is the translation parameter of the wavelet.

Compared to the traditional definition of the CMW, the CMW adopted in this chapter is modified slightly, by changing the scaling factor $1/\sqrt{a}$ to $1/a$. The simplified Complex Morlet Wavelet (CMW) [51, 79] is adopted in the algorithm for harmonic analysis, defined as

$$\varphi\left(\frac{t}{a}\right) = \frac{1}{\sqrt{a}} \frac{1}{\sqrt{\pi f_b}} e^{-\left(\frac{t}{a}\right)^2 / f_b} e^{j2\pi f_c \left(\frac{t}{a}\right)} \quad (5.1)$$

where f_b is the bandwidth parameter and;

f_c is the centre frequency of the wavelet.

Because of the analytic nature, CMW is able to separate amplitude and phase information. From the classical uncertainty principle, it is well known that localization in one domain necessarily comes at the cost of localization in the other. The time-frequency localization is measured in the mean squares sense and is represented as a Heisenberg box. The area of the Heisenberg box is limited

$$\text{by } \Delta t \times \Delta \omega \geq \frac{1}{2}, \quad (5.2)$$

where $\Delta \omega$ is the frequency resolution, and

Δt is the time resolution.

For a dilated CMW,

$$\Delta\omega = \frac{1}{a\sqrt{f_b}}, \text{ \& } \Delta t = \frac{a\sqrt{f_b}}{2}. \quad (5.3)$$

The CMW achieves a desirable compromise between time resolution and frequency resolution, with the area of the Heisenberg box equal to 0.5.

Fig.5.1 shows the filter banks produced for CMW, with $f_b=2$ $f_c=1$ and for $a=1$ to 501. It shows the Fourier Transform of 5.1, which is a frequency to magnitude function. The filter banks produced by the CMW have very good frequency resolution at low frequencies. The frequency resolution becomes poorer and poorer as the wavelet centre frequency increases. The bandpass filters at large dilations would have large lobe heights in frequency domain, by the factor of \sqrt{a} . This is not a desirable feature for harmonic analysis of power signals as current harmonics have smaller magnitudes at high frequencies. If the bandpass filters have lobe heights inversely proportional frequencies, the small magnitudes of higher order harmonics would further be scaled by the magnitudes of the bandpass filters, resulting in erroneous estimation of harmonic frequencies, amplitudes and phases. Fig.5.1 shows the filter banks produced for the CMW.

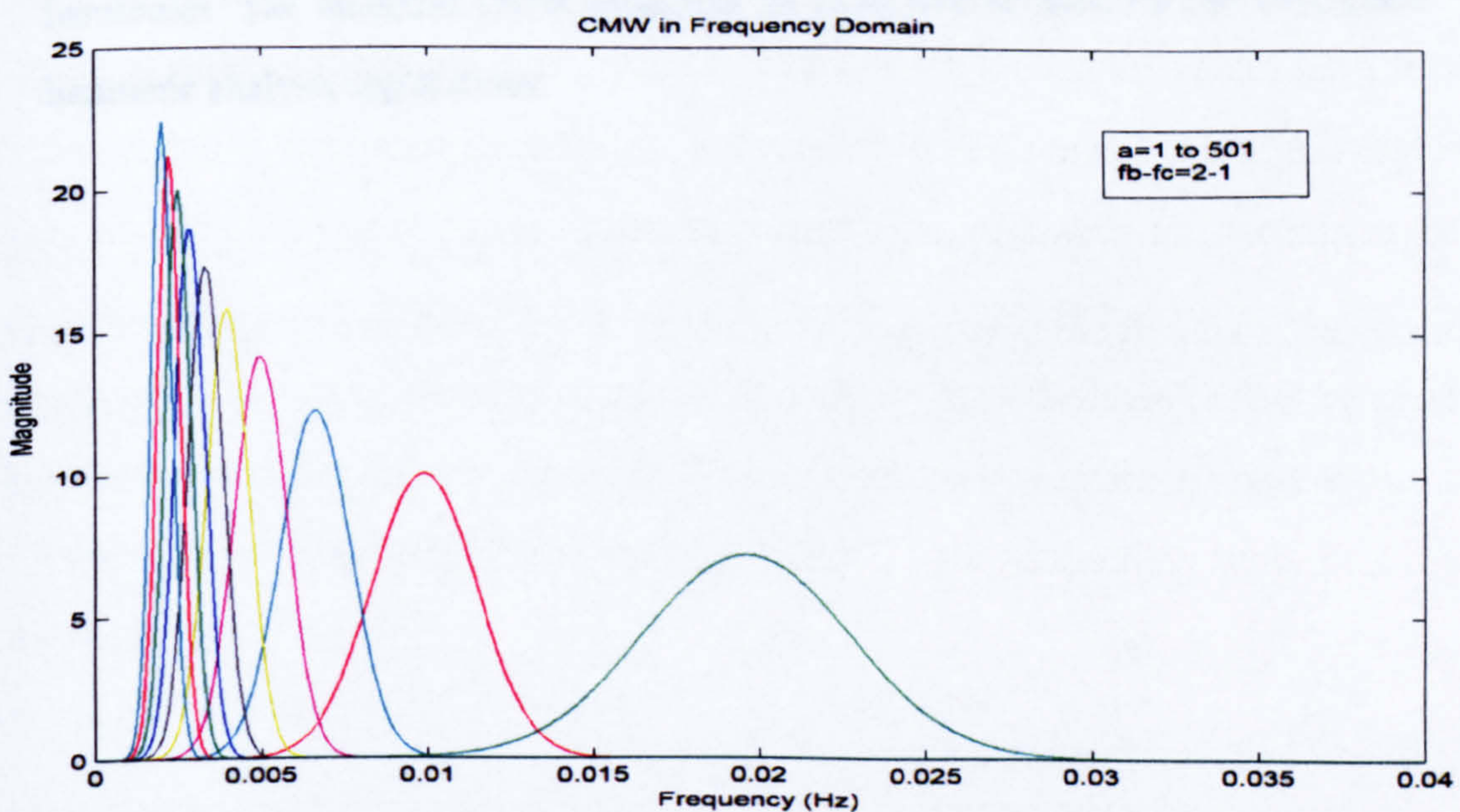

Fig.5.1 Filter banks by CMW

The definition of the CMW shown in (5.1) is modified slightly, with the scaling factor $1/\sqrt{a}$ changed to $1/a$, as in (5.4).

$$\varphi\left(\frac{t}{a}\right) = \frac{1}{a} \frac{1}{\sqrt{\pi f_b}} e^{-\left(\frac{t}{a}\right)^2 / f_b} e^{j2\pi f_c \left(\frac{t}{a}\right)} \quad (5.4)$$

The Fourier transform of (5.4) is given as

$$\Phi(af) = e^{-\pi^2 f_b (af - f_c)^2} \quad (5.5)$$

Fig.5.2 shows the filter banks generated from the modified CMW. The importance of the modification to the CMW is the bandpass filters generated by dilation of the modified mother CMW would have the same lobe height for all harmonic frequencies. As seen in Fig.5.2 filter banks generated by (5.5) exhibit the same lobe height for all harmonic frequencies in frequency domain. The time spread and frequency spread of the modified CMW are the same as the original CMW. The modified CMW is more suitable for estimating harmonics with very small amplitudes compared to adjacent harmonics, commonly found in sub-harmonics, inter-harmonics and higher order harmonics. The modified CMW described by (5.4) will be used for the subsequent harmonic analysis applications.

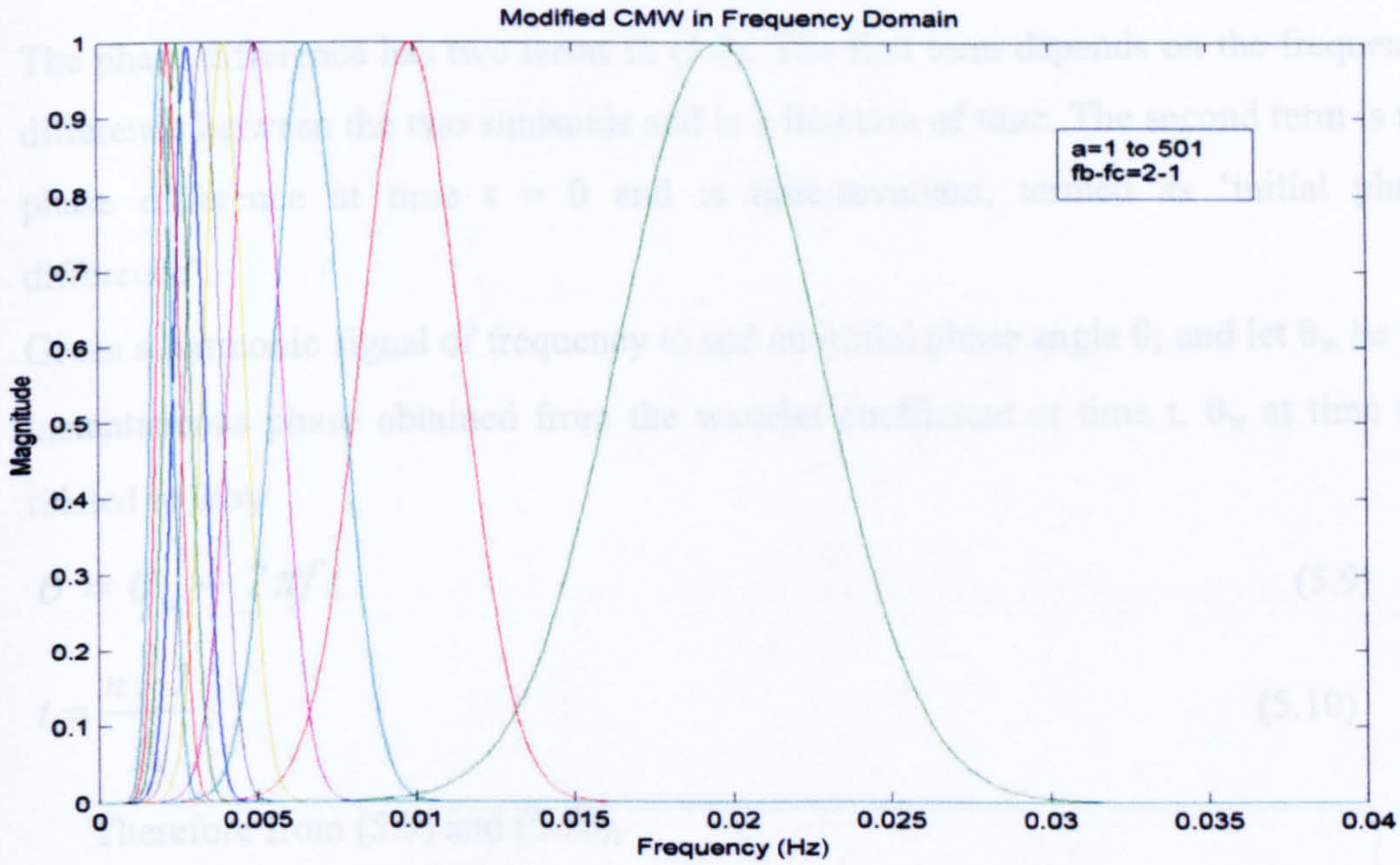

Fig.5.2 Filter banks by the modified CMW

5.3 Harmonics detection

As discussed in [80], the harmonic frequencies contained in a power signal can be determined by the wavelet ridges. With the modified CMW suggested in (5.4), the corresponding harmonics amplitudes would be determined directly by

$$A(u) = 2|Wf(u, a)|. \quad (5.6)$$

where $|Wf(u, a)|$ is the wavelet coefficient at location u and scale a .

The CMW, given its analytic nature, can preserve signal phase information. The phase information contained in the wavelet coefficients is termed 'instantaneous phase'. Each sampled data point in the time signal has a wavelet coefficient related to it.

Consider the two sinusoids defined as

$$\begin{aligned} v_1 &= A_1 \cos(\omega_1 t + \theta_1) \\ v_2 &= A_2 \cos(\omega_2 t + \theta_2); \end{aligned} \quad (5.7)$$

Their phase difference at any time t is

$$\angle v_2 - \angle v_1 = \omega_2 t + \theta_2 - (\omega_1 t + \theta_1) = (\omega_2 - \omega_1)t + \theta_2 - \theta_1. \quad (5.8)$$

The phase difference has two terms in (5.8). The first term depends on the frequency difference between the two sinusoids and is a function of time. The second term is the phase difference at time $t = 0$ and is time-invariant, termed as 'initial phase difference'.

Given a harmonic signal of frequency ω and an initial phase angle θ ; and let θ_w be the instantaneous phase obtained from the wavelet coefficient at time t . θ_w at time t is related to θ by

$$\theta = \theta_w - 2\pi f t \quad (5.9)$$

$$t = \frac{n-1}{f_s} \quad (5.10)$$

Therefore from (5.9) and (5.10),

$$\theta = \theta_w - 2\pi f \left(\frac{n-1}{f_s} \right) \quad (5.11)$$

The initial phase angle θ , i.e., the phase angle of the harmonic signal at time $t = 0$ ($n = 1$), is

$$\begin{aligned} \theta &= \theta_w - 2\pi f (0) \\ \theta &= \theta_w \end{aligned} \quad (5.12)$$

The wavelet coefficients at data ends of the signal data would be distorted by edge effect [32]. Therefore wavelet coefficients which are sufficiently away from the data ends of the sampled signal data should be used for initial phase angle estimation.

From (Eq.4.8), the initial phase difference between any two harmonics is given by

$$\theta_2 - \theta_1 = (\theta_{w2} - \theta_{w1}) - 2\pi(n-1) \frac{(f_2 - f_1)}{f_s} \quad (5.13)$$

The wavelet coefficient generated for the data at the centre position of the signal is used for phase estimation.

5.4 Discrimination of adjacent frequencies

Fig.5.3 shows the plot of Fourier Transform of two modified CMWs with centre frequencies of f_c/a_1 and f_c/a_2 respectively in the frequency domain, obtained from

(Eq.5.5). The two peaks in Fig.5.3 must be separated apart sufficiently to discriminate adjacent frequencies.

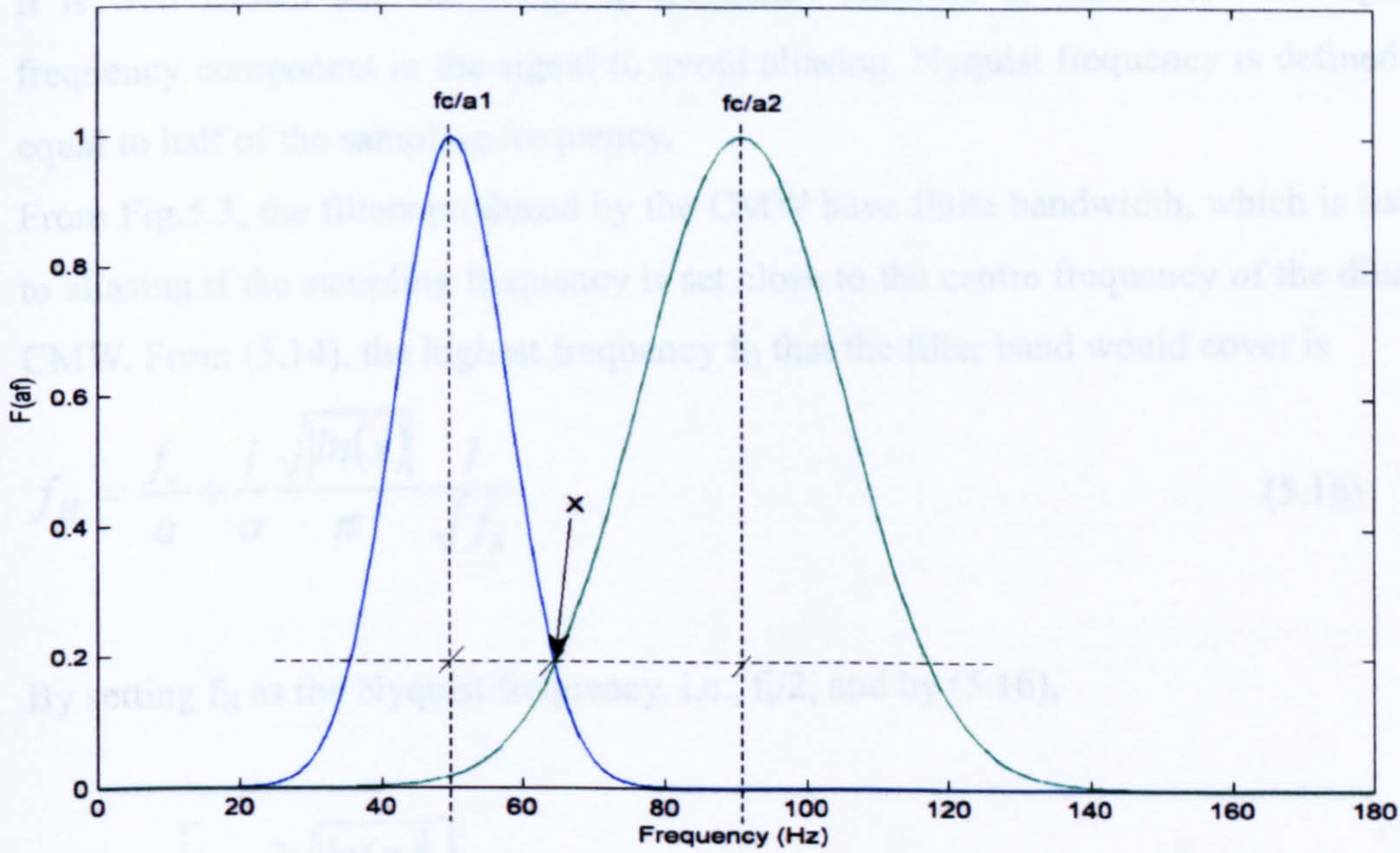

Fig.5.3 Fourier Transform of modified CMWs with $f_c=f_1$ & f_2

From [80], the $f_c\sqrt{f_b}$ of the modified CMW should satisfy the following condition to achieve the discrimination.

$$f_c\sqrt{f_b} \geq \frac{\sqrt{|\ln(x)|}}{\pi} \left| \frac{f_1 + f_2}{f_1 - f_2} \right|. \quad (5.14)$$

The x in (5.14) should ideally be very small for accurate harmonic frequency and amplitude estimation and would depend on

- the relative amplitudes of the harmonics;
- the accuracy demanded in the amplitude estimation.

The selection of the x value would need to be compromised with the signal length to be used for analysis. It is found that $x=0.1$ is sufficient for accurate frequency and amplitude detection if the amplitudes of adjacent frequencies do not differ very much from each other, which gives

$$\frac{\sqrt{|\ln(0.1)|}}{\pi} = 0.483 \approx 0.5. \quad (5.15)$$

5.5 Sampling frequency and signal length

It is well known that the sampling frequency must be at least twice the highest frequency component in the signal to avoid aliasing. Nyquist frequency is defined as equal to half of the sampling frequency.

From Fig.5.3, the filters produced by the CMW have finite bandwidth, which is liable to aliasing if the sampling frequency is set close to the centre frequency of the dilated CMW. From (5.14), the highest frequency f_H that the filter band would cover is

$$f_H = \frac{f_c}{a} + \frac{1}{a} \frac{\sqrt{|\ln(x)|}}{\pi} \frac{1}{\sqrt{f_b}}. \quad (5.16)$$

By setting f_H as the Nyquist frequency, i.e., $f_s/2$, and by (5.16),

$$f_s \geq 2f \left[1 + \frac{2\sqrt{|\ln(x)|}}{\pi f_c \sqrt{f_b}} \right]. \quad (5.17)$$

The minimum sampling frequency is dependent on the $f_c\sqrt{f_b}$ of the modified CMW. From (5.15), and with $f_c\sqrt{f_b} \geq 1.14$, (5.17) gives

$$f_s \geq 2f \left[1 + \frac{0.483}{1.13} \right] = 2.855f. \quad (5.18)$$

Therefore with the modified CWM, the sampling frequency lies between 2 to 3 times of the highest harmonic frequency in the harmonic signal. The larger the factor $f_c\sqrt{f_b}$, the lower would be the minimum sampling frequency.

The signal length is controlled by the time width of the wavelet required to achieve a mean zero value. It is estimated that the signal length is given as

$$T = b \left(\frac{f_c \sqrt{f_b}}{2} \right) \frac{1}{f}, \quad (5.19)$$

where b is a constant.

When very accurate estimation in both frequency and amplitude is required, a larger value of b is to be used. In any case, the longer the time window, the better would be

the estimation of the frequency and amplitude of the harmonics. On the other hand, for time event localization, the shorter the time window the better would be the localization of the time event. Hence a balance should be struck between the two.

The value of b is chosen as 10. Therefore the time width, T , of the CMW is determined as

$$T \geq \frac{5f_c \sqrt{f_b}}{f}. \quad (5.20)$$

5.6 The proposed harmonics detection algorithm

Fig.5.4 shows the flow chart of the proposed computational algorithm based on the modified CMW. The algorithm is implemented in Matlab software

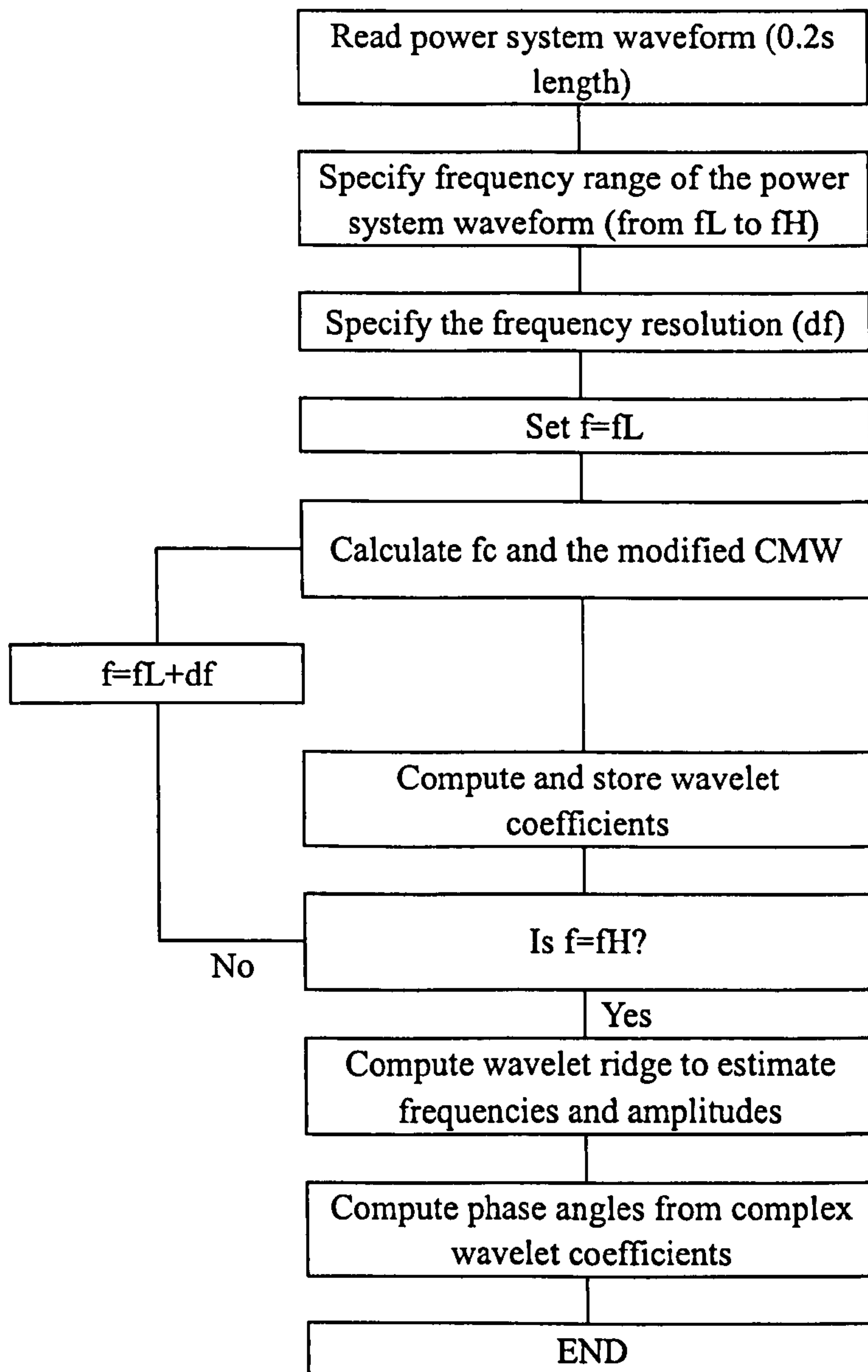

Fig.5.4 Flow chart of the proposed algorithm

5.7 Simulation Results Based on Synthesized Waveforms

Two tests based on synthesized waveforms are conducted. The sampling frequency is set at 6400Hz which is a common setting of commercially available power quality meters.

DFT computed by FFT is used to compare the results of the proposed wavelet-based algorithm. Hanning window is applied to the synthesized waveforms before computing FFT.

Test 1

A synthesized waveform is constructed from harmonic components as shown in Table 5.1. The synthesized waveform is stationary and linear, i.e., the frequencies and amplitudes of the harmonic components are constant throughout the entire waveform length of 0.2s. The synthesized waveform is shown in Fig.5.5. The estimated results are compared in Table 5.2.

Synthesized Waveform		
Frequency (Hz)	Amplitude	Phase (degree).
49.5	311	0
102	288	10
148.5	280	-15
247.5	225	-12
346.5	180	-20
445.5	155	-14
544.5	130	30
643.5	102	36
742.5	80	42
811	76	11
940.5	53	5
1336.5	20	8
1534.5	15	20
1633.5	13	-30
1831.5	9	-8
1930.5	7	9
2128.5	3	35

Table 5.1 Harmonic contents of the synthesized waveform

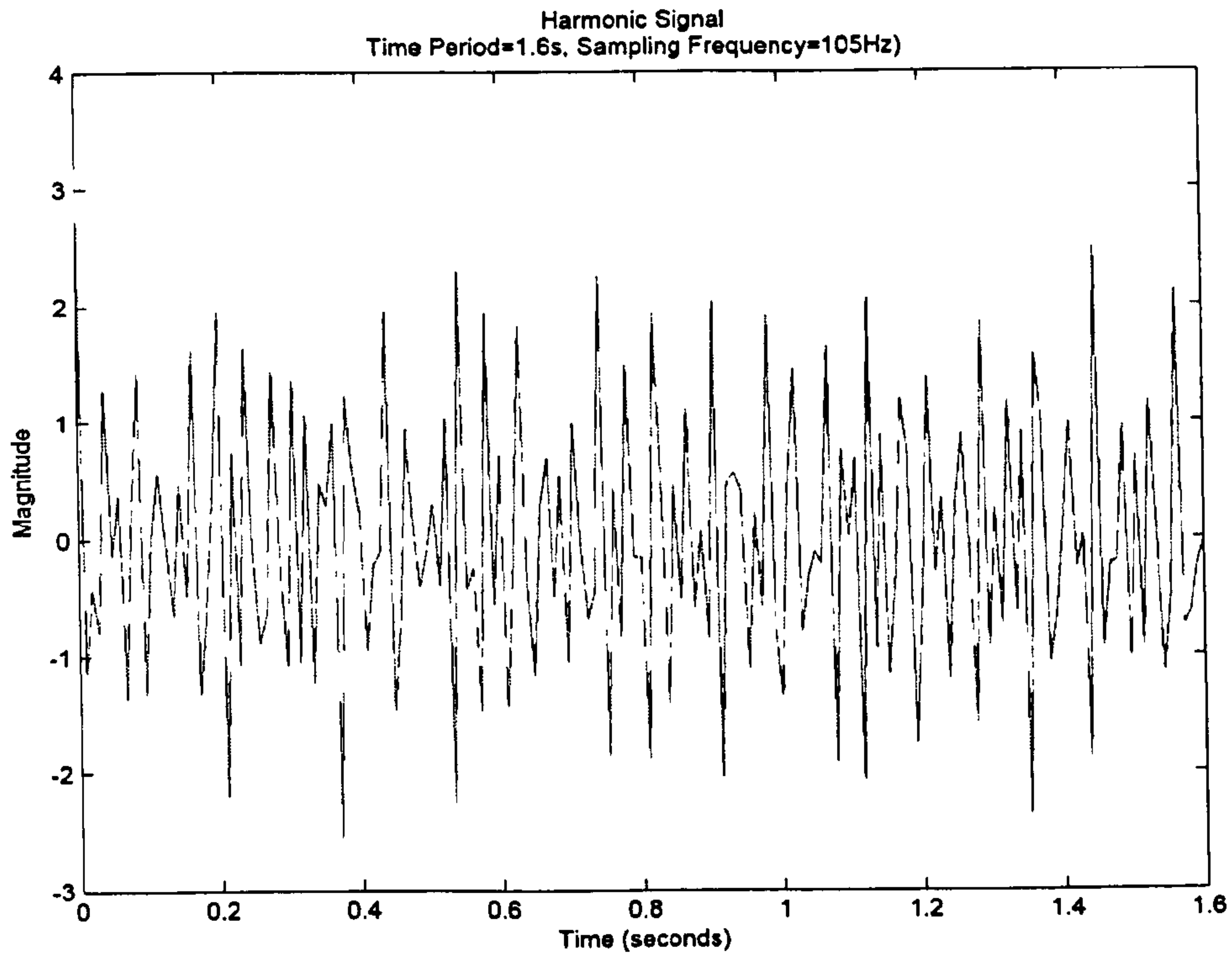

Fig.5.5 The synthesized waveform for Test 1

Synthesized Waveform			Proposed Algorithm			DFT		
Freq. (Hz)	Amp	Ph.	Freq. (Hz)	Am p.	Ph.	Freq. (Hz)	Am p.	Ph.
49.5	311	0	49.5	311	0	49.5	311	0
102	288	10	102	288	10	102	288	10
148.5	280	-15	148.5	280	-15	148.5	280	-15
247.5	225	-12	247.5	225	-12	247.5	225	-12
346.5	180	-20	346.5	180	-20	346.5	180	-20
445.5	155	-14	445.5	155	-14	445.5	155	-14
544.5	130	30	544.5	130	30	544.5	130	30
643.5	102	36	643.5	102	36	643.5	102	36
742.5	80	42	742.5	80	42	742.5	80	42
811	76	11	811	76	11	811	76	11
940.5	53	5	940.5	53	5	940.5	53	5
1336.5	20	8	1336.5	20	8	1336.5	20	8
1534.5	15	20	1534.5	15	20	1534.5	15	20
1633.5	13	-30	1633.5	13	-30	1633.5	13	-30
1831.5	9	-8	1831.5	9	-8	1831.5	9	-8
1930.5	7	9	1930.5	7	9	1930.5	7	9
2128.5	3	35	2128.5	3	35	2128.5	3	35

Table 5.2 Estimated results by the proposed algorithm & DFT for Test 1

From Table 5.2, it can be seen that both the proposed algorithm and DFT are able to estimate the harmonics accurately. As the synthesized waveform is stationary and linear, DFT should pose no problem in producing accurate results. It is verified that the proposed algorithm can perform as good as DFT in estimating stationary and linear waveforms.

Test 2

A synthesized waveform is basically constructed from harmonic components as shown in Table 5.1 above, except that the amplitudes of harmonic components at 49.5Hz, 148.5Hz and 247.5Hz are reduced to 0.7 times the values shown in Table 5.1, for the time period 0.2s to 0.4s. The waveform length in this test is 0.6s. The synthesized waveform is therefore non-stationary and linear. Fig.5.6 shows the synthesized waveform. The estimated results are compared in Table 5.3.

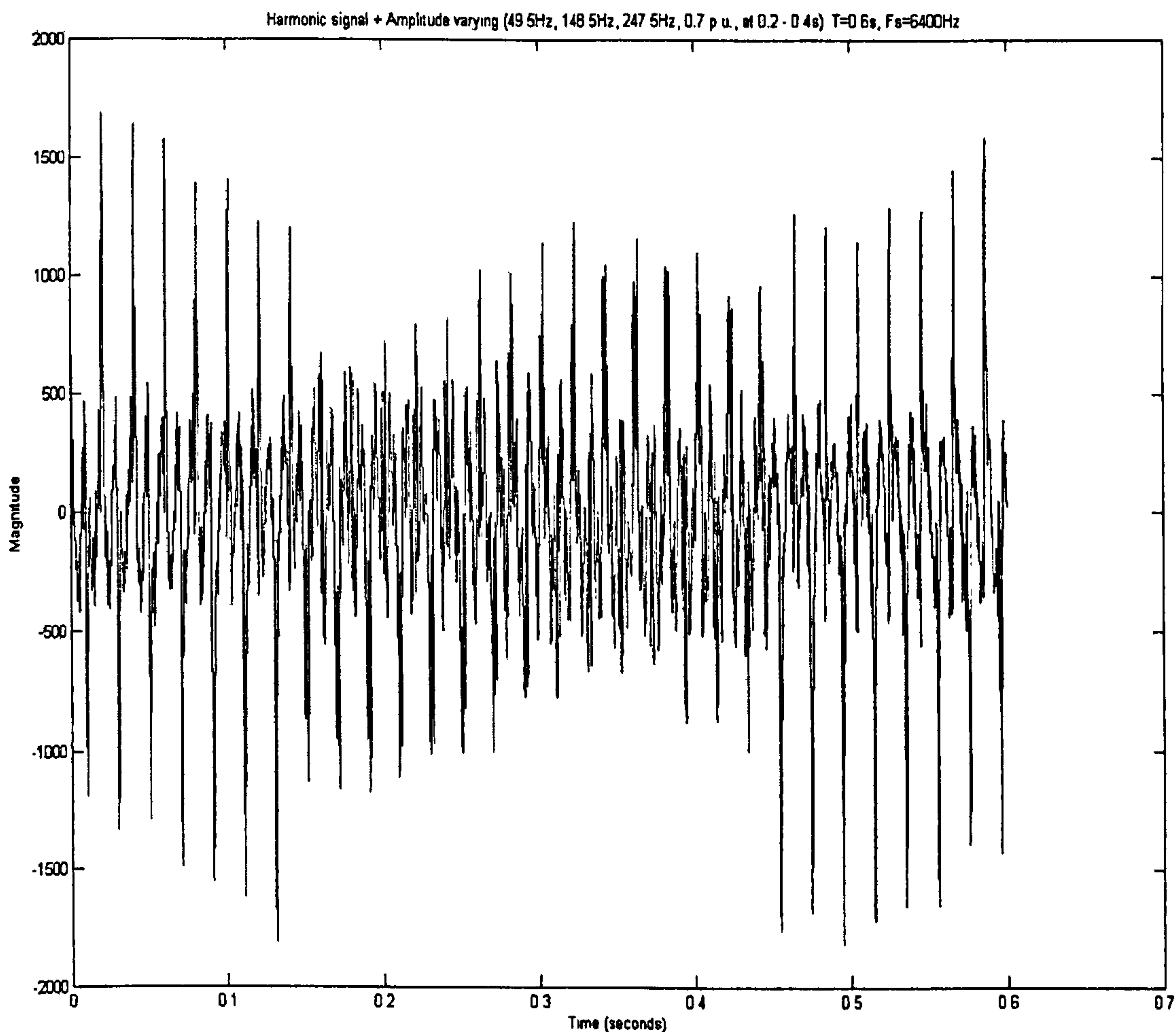

Fig.5.6 The synthesized waveform for Test 2

Synthesized Waveform			Proposed Algorithm			DFT		
Freq. (Hz)	Amp.	Ph.	Freq. (Hz)	Amp.	Ph.	Freq. (Hz)	Am p.	Ph.
49.5	311 (217.7)*	0	49.5	311 (217.7)*	27.8	49.5	229.7	21.5
102	288	10	102	288	10	102	288	10
148.5	280 (196)*	-15	148.5	280 (196)*	68.5	148.5	173.3	52.3
247.5	225 (157.5)*	-12	247.5	225 (157.5)*	127.2	246.3	105.2	100
346.5	180	-20	346.5	180	-20	346.5	179	-20
445.5	155	-14	445.5	155	-14	445.5	155.6	-14.1
544.5	130	30	544.5	130	30	544.5	130	30.1
643.5	102	36	643.5	102	36	643.5	102	36.1
742.5	80	42	742.5	80	42	742.5	79.9	41.9
811	76	11	811	76	11	811	76.1	11
940.5	53	5	940.5	53	5	940.5	53	5
1336.5	20	8	1336.5	20	8	1336.5	20	7.9
1534.5	15	20	1534.5	15	20	1534.5	15	19.9
1633.5	13	-30	1633.5	13	-30	1633.5	13	-30
1831.5	9	-8	1831.5	9	-8	1831.5	8.9	-8.1
1930.5	7	9	1930.5	7	9	1930.5	7	9.1
2128.5	3	35	2128.5	3	35	2128.5	3	36

Table 5.3 Estimated results by the proposed algorithm & DFT for Test 2

* note: values in bracket are amplitude values in the time period 0.2s to 0.4s

Based on the results shown in Table 5.3, the discussions are divided into two parts.

A) Harmonic components with steady amplitude (All components except 49.5Hz, 148.5Hz, 247.5Hz)

1. On frequency estimation, both the proposed algorithm and DFT perform well. As the table.5.3 shows, apart from frequencies 49.5Hz, 148.5Hz, 247.5Hz, other components can derive good estimations in frequencies and amplitudes.
2. On amplitude estimation, the proposed algorithm performs well, while DFT results show small errors. As the table.5.3 shows, errors appear in frequencies: 445.5Hz, 742.5Hz, 811Hz and 1831.5Hz.

3. On phase angle estimation, the proposed algorithm performs well, while DFT results show small errors. It shows errors in all frequency components except 102Hz, 811Hz, 940.5Hz, 1633.5Hz and 2128.5Hz.
- B) Harmonic components with varying amplitudes (49.5Hz, 148.5Hz, 247.5Hz in time period 0.2s to 0.4s)
1. On frequency estimation, the proposed algorithm performs well; while DFT shows an error in estimating the harmonic frequency of 247.5Hz (shows 246.3HZ). The accuracy of DFT on frequency estimation is dependent on the location of the amplitude change on the harmonic waveform, while the proposed algorithm is not affected by amplitude variations.
 2. On amplitude estimation, the proposed algorithm is able to estimate the amplitude variations precisely, while the results produced by DFT are erroneous. As the table.5.3 shows, the DFT results are 229.7, 173.3 and 105.2. DFT uses sinusoidal waveforms as basis functions which are global in nature; local changes are therefore not represented. By dividing the synthesizing waveform into segments and then performing DFT, better results on amplitude estimations would be produced. However a prior knowledge of the amplitude variations is needed when segmenting the waveform. The estimated amplitude variation results produced by the proposed algorithm are plotted in Fig.5.7 to 5.9. The sharp dips on the amplitude plots are locations of amplitude changes.
 3. On phase estimation, both the proposed algorithm and DFT are unable to estimate the initial phase angles. The results are expected because phase angle estimation is affected by sudden changes in amplitudes.

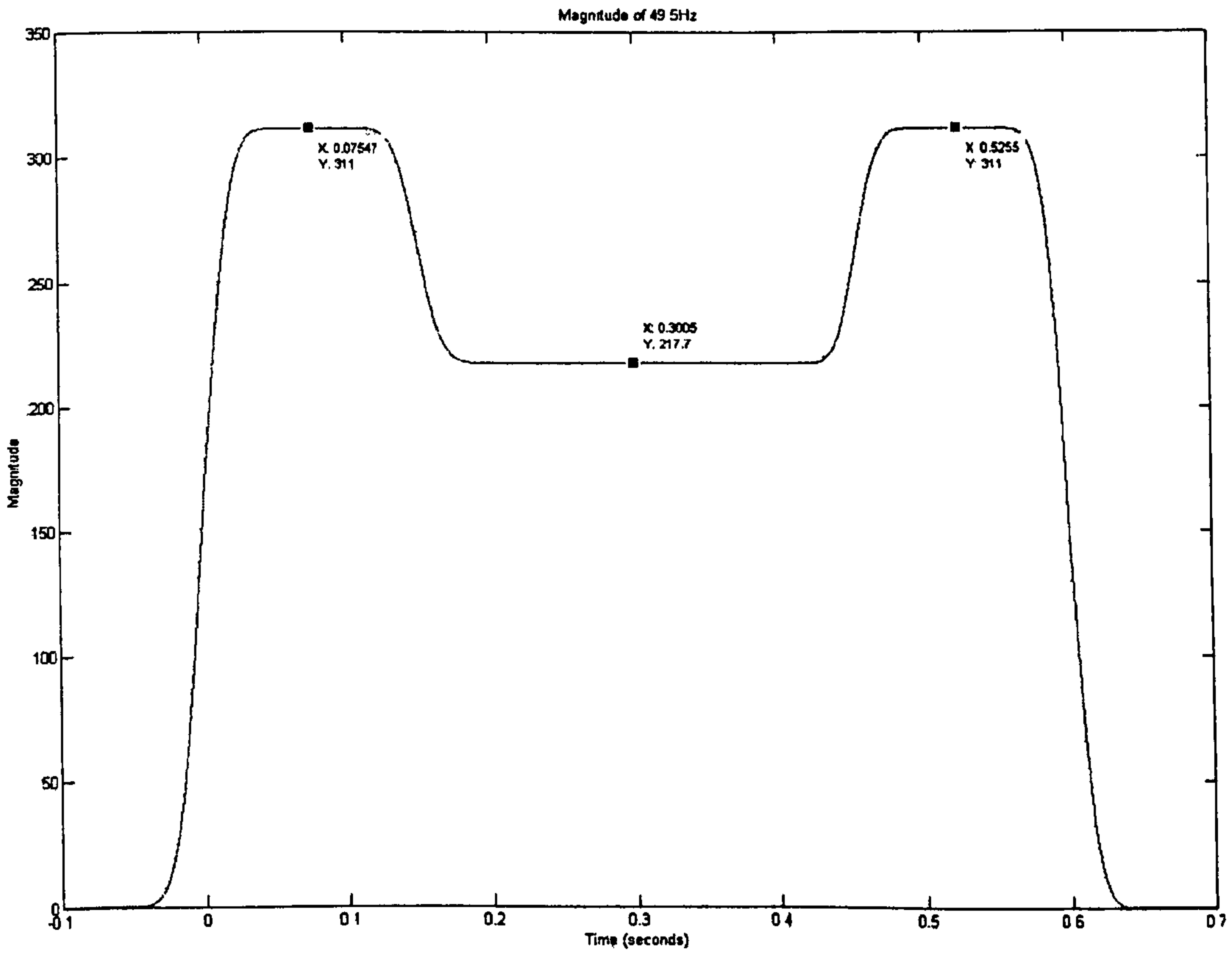

Fig. 5.7 Amplitude variation at 49.5Hz by the proposed algorithm

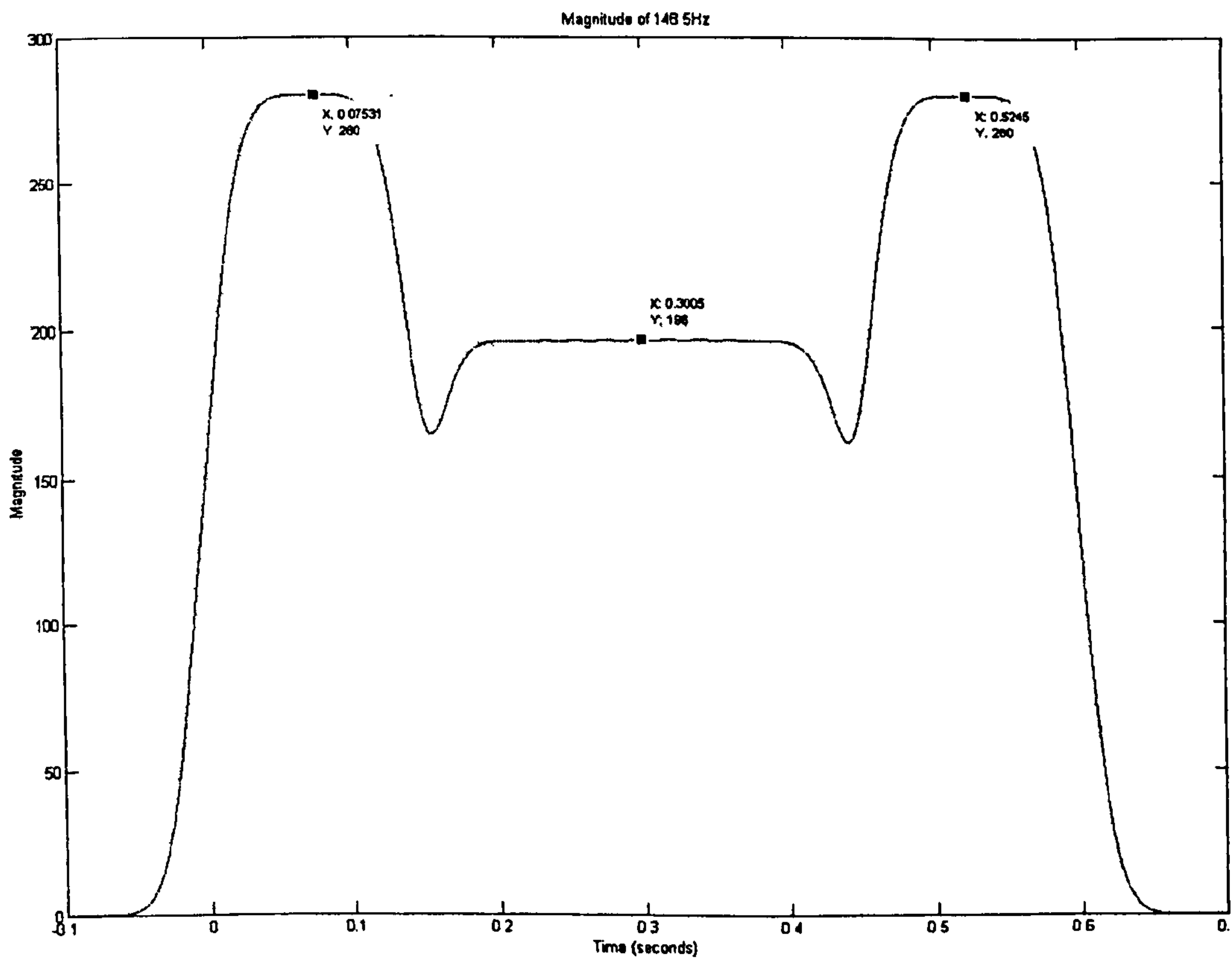

Fig.5.8 Amplitude variation at 148.5Hz by the proposed algorithm

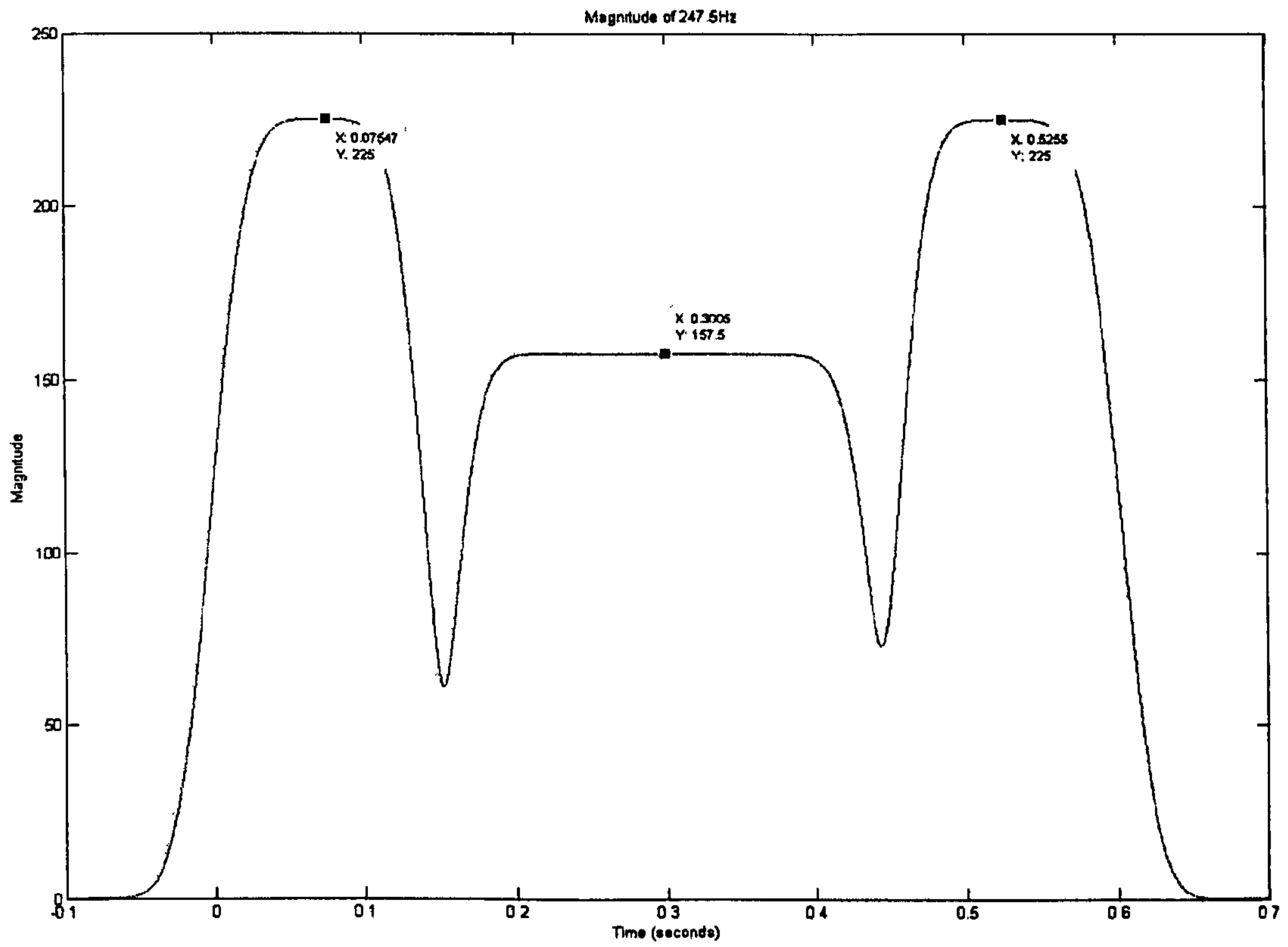

Fig.5.9 Amplitude variation at 247.5Hz by the proposed algorithm

5.8 Conclusion

A proposed algorithm based on the complex continuous wavelet transform with the Complex Morlet Wavelet as the mother wavelet is introduced for analyzing harmonic components of power system waveforms in this chapter.

Test results based on synthesized waveforms reveal that the proposed algorithm performs well with both stationary and non-stationary waveforms. The performance of the proposed algorithm in estimating stationary waveforms is as good as DFT, and in addition to this, it performs much better than DFT for non-stationary waveforms.

Chapter 6

Wavelet-Based Algorithm for Nonstationary Power System Waveform Analysis

6.1 Introduction

The Wavelet-Based algorithm for nonstationary power system waveform analysis is important for smart grid because harmonic waveforms in smart grid need to be extraction. Short-time Fourier Transform (STFT) and Gabor Transform (GT) were used for harmonic studies of nonstationary power system waveforms which are basically Fourier transform (FT)-based methods. These methods have certain limitations [82]. To overcome the limitations in these existing methods, Wavelet Transform (WT)-based algorithm has been developed to estimate the frequency and time information of a harmonic signal [54, 78, 80, 82]. Because of the shifting and scaling operations of the WT, it is most suitable to problems involving nonstationary power system harmonic waveforms.

This chapter presents a WT-based algorithm for reconstructing the harmonic waveforms from the complex CWT coefficients. This is useful for identifying the amplitude variations of the nonstationary harmonics over the estimation period.

Discrete wavelet transform (DWT) is receiving increasing attention due to its fast and efficient computation algorithm and the ability to extract signal features. Applications are found in power system transient analysis and fault detections where time information of the signal is to be analyzed [78, 80, 83]. DWT is able to divide harmonic components of a signal in frequency bands for ready inspection, but is liable to aliasing problems and amplitude distortions without careful selection of frequency bands.

Complex Continuous Wavelet Transform (CCWT) is adopted for harmonic analysis which can identify harmonic frequencies and preserve time and phase information [77, 82]. The simplified Complex Morlet Wavelet (CMW) [77] is chosen for harmonics analysis due to its smooth and harmonic-like waveform.

Scalogram and wavelet ridges are used to extract frequency and amplitude information from wavelet coefficients computed from CCWT [84]. The WT-based algorithm by using CMW is able to estimate harmonic frequencies accurately with a shorter harmonic signal as compared to DFT [82].

Compared to the traditional definition of the CMW, the CMW adopted in this chapter is modified slightly, by changing the scaling factor $1/\sqrt{a}$ to $1/a$, as previous shown in (5.4).

$$\varphi\left(\frac{t}{a}\right) = \frac{1}{a} \frac{1}{\sqrt{\pi f_b}} e^{-\left(\frac{t}{a}\right)^2 / f_b} e^{j2\pi f_c \left(\frac{t}{a}\right)} \quad (5.4)$$

where f_b is the bandwidth parameter, ω_c is the wavelet centre frequency and a is the dilation factor.

The Fourier Transform of (5.4) is

$$\Phi(af) = e^{-\pi^2 f_b (af - f_c)^2} \quad (5.5)$$

where $f_c = \omega_c / (2\pi)$.

The filter banks generated by (5.5) exhibit the same lobe height for all harmonic frequencies in frequency domain. The figure is shown in Fig.5.2. The modified CMW is more suitable for estimating harmonics with very small amplitudes compared to adjacent harmonics, commonly found in sub-harmonics, inter-harmonics and higher order harmonics.

6.2 Waveform Reconstruction Algorithm

Reconstruction means reconstruct the harmonic waveforms from the complex CWT coefficients for identifying the amplitudes variations and frequency information of the nonstationary harmonics over the estimation period. Actually, reconstruction means extraction.

The CCWT by using the modified CWM in (6.1) is given as

$$Wf(u,a) = \int_{-\infty}^{+\infty} f(t) \frac{1}{a} \frac{1}{\sqrt{\pi f_b}} e^{-\left(\frac{t-u}{a}\right)^2 / f_b} e^{-j\omega_c \left(\frac{t-u}{a}\right)} dt \quad (6.1)$$

The real part and imaginary part of the complex wavelet coefficients generated by (6.1) are shown in (6.2) and (6.3) respectively.

$$\begin{aligned} & Re[Wf(u,a)] \\ &= \int_{-\infty}^{+\infty} f(t) \frac{1}{a} \frac{1}{\sqrt{\pi f_b}} e^{-\left(\frac{t-u}{a}\right)^2 / f_b} \cos\left[\frac{\omega_c}{a}(t-u)\right] dt \end{aligned} \quad (6.2)$$

$$\begin{aligned} & Im[Wf(u,a)] \\ &= - \int_{-\infty}^{+\infty} f(t) \frac{1}{a} \frac{1}{\sqrt{\pi f_b}} e^{-\left(\frac{t-u}{a}\right)^2 / f_b} \sin\left[\frac{\omega_c}{a}(t-u)\right] dt \end{aligned} \quad (6.3)$$

Given a harmonic signal represented as

$$f(t) = A \cos \omega t \quad (6.4)$$

The real part of the complex CWT coefficient for (6.4) from (6.2) is

$$\begin{aligned} & Re [Wf(u,a)] \\ &= \frac{A}{a\sqrt{\pi f_b}} \int_{-\infty}^{+\infty} e^{-\left(\frac{t-u}{a}\right)^2 / f_b} \cos \omega t \cos\left[\frac{\omega_c}{a}(t-u)\right] dt \end{aligned} \quad (6.5)$$

By change of variable, (6.5) becomes,

$$\begin{aligned} & Re [Wf(u,a)] \\ &= \frac{A}{a\sqrt{\pi f_b}} \int_{-\infty}^{+\infty} e^{-\left(\frac{t}{a}\right)^2 / f_b} \cos[\omega(t+u)] \cos\frac{\omega_c}{a} t dt \end{aligned} \quad (6.6)$$

The complex wavelet coefficient will be the largest when the frequency of the

harmonic component is equal to the wavelet centre frequency at the dilation a . Substitute $\omega = \omega_c/a$ into (6.6),

$$\begin{aligned} & \text{Re} [Wf(u, a)] \\ &= \frac{A}{a\sqrt{\pi f_b}} \int_{-\infty}^{+\infty} e^{-\left(\frac{t}{a}\right)^2 / f_b} (\cos \omega u \cos^2 \omega t - \sin \omega u \sin \omega t \cos \omega t) dt \end{aligned} \quad (6.7)$$

The imaginary part of the complex CWT coefficient for (6.4) from (6.3) is calculated similarly as

$$\begin{aligned} & \text{Im} [Wf(u, a)] \\ &= -\frac{A}{a\sqrt{\pi f_b}} \int_{-\infty}^{+\infty} e^{-\left(\frac{t}{a}\right)^2 / f_b} \cos[\omega(t+u)] \sin \omega t dt \end{aligned} \quad (6.8)$$

Shifting the imaginary part of the complex CWT coefficient by 90° backward in time, (6.10) becomes

$$\begin{aligned} & \text{Im}[Wf(u + \frac{\pi}{2\omega}, a)] \\ &= \frac{A}{a\sqrt{\pi f_b}} \int_{-\infty}^{+\infty} e^{-\left(\frac{t}{a}\right)^2 / f_b} (\cos \omega u \sin^2 \omega t + \sin \omega u \sin \omega t \cos \omega t) dt \end{aligned} \quad (6.9)$$

Adding (6.4) and (6.3) produces

$$\begin{aligned} & \text{Re}[Wf(u, a)] + \text{Im}[Wf(u + \frac{\pi}{2\omega}, a)] \\ &= A \cos \omega u \end{aligned} \quad (6.10)$$

(6.10) verifies mathematically that for a sinusoidal waveform of sufficient length, the waveform can be fully reconstructed by adding the real part of the corresponding complex CWT coefficients to the imaginary part of the corresponding complex CWT coefficients being shifted backward in time by 90° . Since the reconstruction is time

invariant, the instantaneous phase of the harmonic component is preserved in the reconstructed waveform.

The flowchart of the proposed power system waveform reconstruction algorithm is shown in Fig. 6.1.

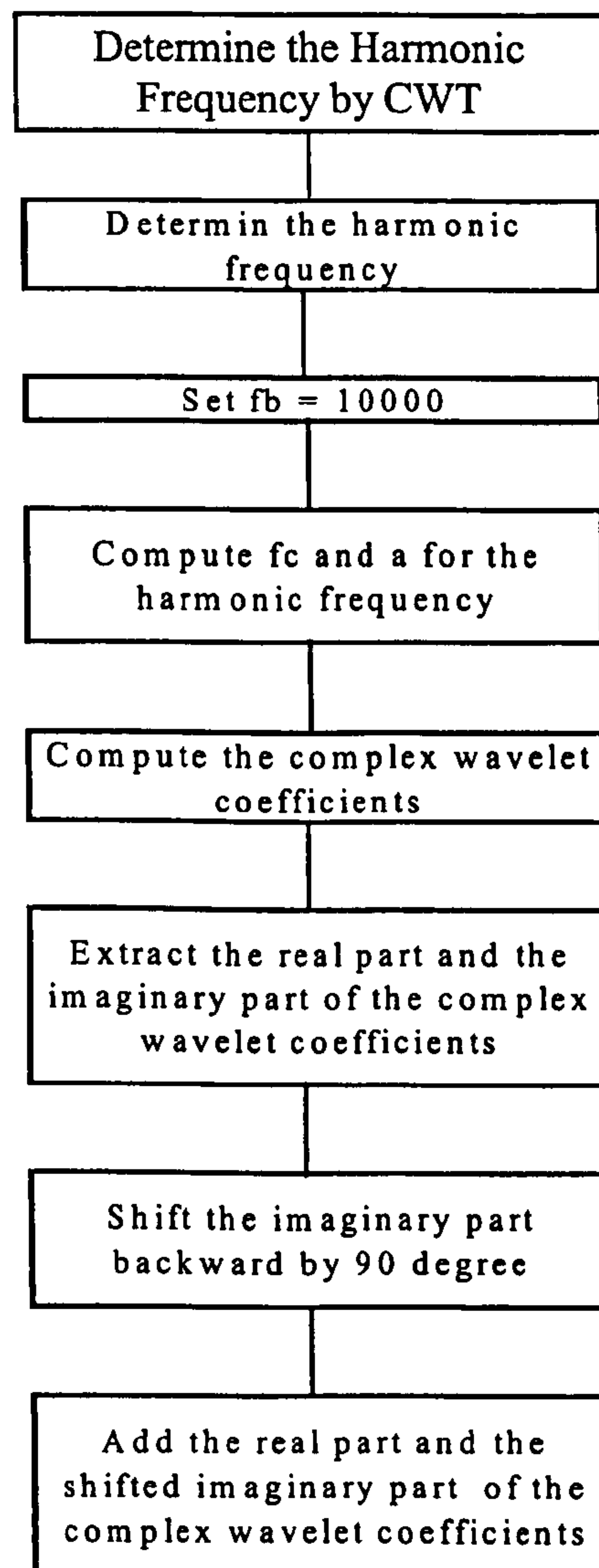

Fig.6.1 Flow chart of the WT-based waveform reconstruction algorithm

6.3 Synthesized Waveforms Reconstruction

A test is conducted to verify the effectiveness of the proposed WT-based waveform reconstruction algorithm.

A waveform describe by (6.11)

$$f(t) = 7 \cos\left(100\pi t + \frac{\pi}{6}\right) + 11 \cos\left(300\pi t + \frac{43\pi}{180}\right) \quad (6.11)$$

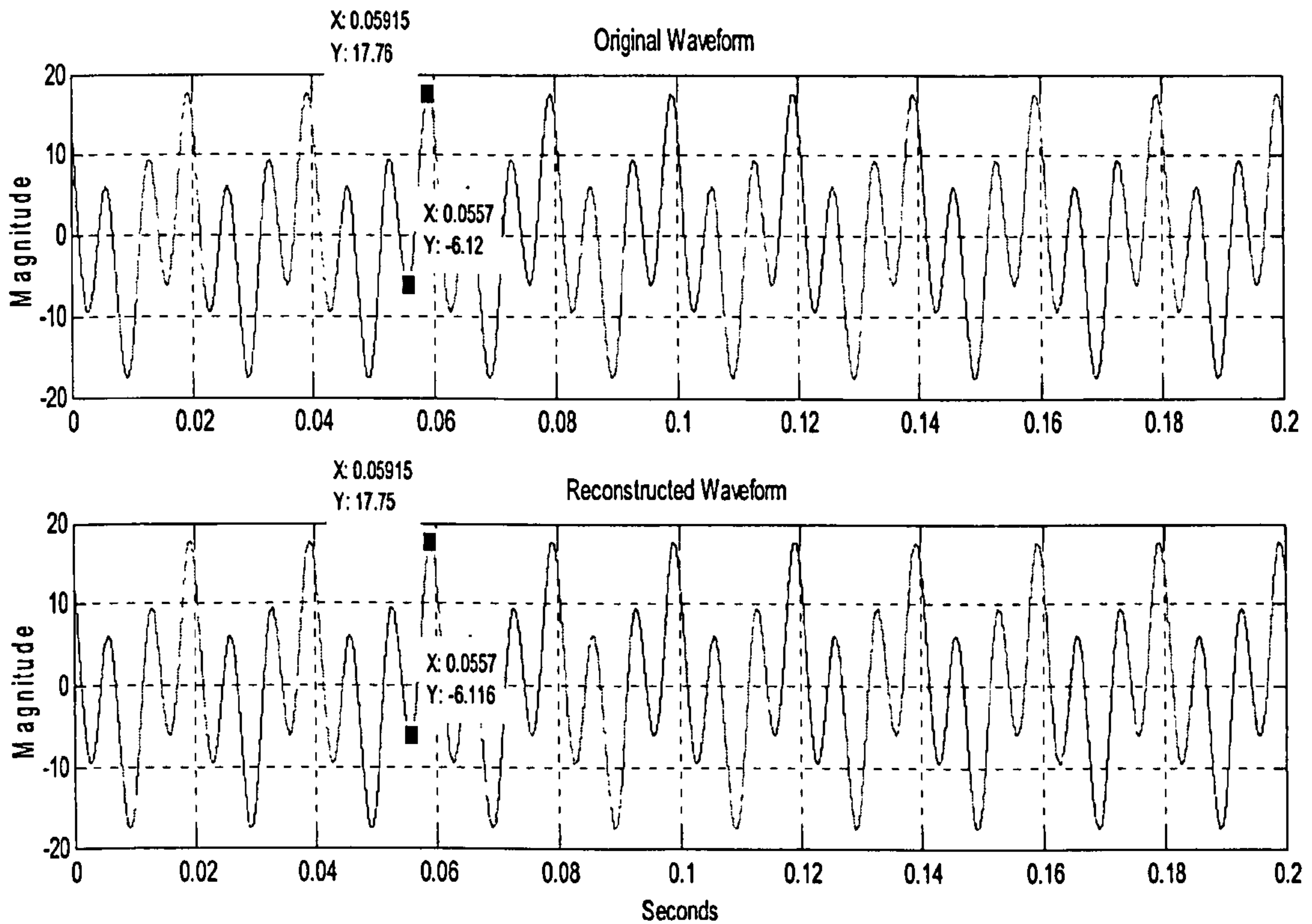

Fig.6.2 Synthesized waveform vs. Reconstructed Waveform

Table 6.1 and Fig.6.2 show a comparison of the synthesized waveform and reconstructed waveform. The reconstructed waveform coincides with the modified waveform. Due to the finite support of the modified CMW, the reconstructed waveform has only a small error.

Corresponding time	Original Signal	Reconstructed Signal
0	14.1070685443019	13.8980455120543
0.004000000000000000	-3.55428078486631	-3.35247490397684
0.008000000000000000	-11.6104541467256	-11.8480020537859
0.012000000000000000	6.77366027700275	6.94432559749783
0.016000000000000000	-5.71599388971278	-5.64189415178936
0.020000000000000000	14.1070685443020	13.8980455120543
0.024000000000000000	-3.55428078486633	-3.35247490397684
0.028000000000000000	-11.6104541467256	-11.8480020537859
0.032000000000000000	6.77366027700274	6.94432559749783
0.036000000000000000	-5.71599388971278	-5.64189415178936
0.040000000000000000	14.1070685443020	13.8980455120543
0.044000000000000000	-3.55428078486634	-3.35247490397689
0.048000000000000000	-11.6104541467256	-11.8480020537859
0.052000000000000000	6.77366027700275	6.94432559749782
0.056000000000000000	-5.71599388971279	-5.64189415178936
0.060000000000000000	14.1070685443019	13.8980455120543
0.064000000000000000	-3.55428078486633	-3.35247490397682
0.068000000000000000	-11.6104541467257	-11.8480020537860
0.072000000000000000	6.77366027700279	6.94432559749785
0.076000000000000000	-5.71599388971279	-5.64189415178935
0.080000000000000000	14.1070685443019	13.8980455120542
0.084000000000000000	-3.55428078486621	-3.35247490397675
0.088000000000000000	-11.6104541467256	-11.8480020537859
0.092000000000000000	6.77366027700272	6.94432559749784
0.096000000000000000	-5.71599388971277	-5.64189415178933

Table.6.1 Synthesized waveform vs. Reconstructed Waveform

6.4 Experimental Results

Experiments are conducted to the following two field waveforms to validate the robustness of the proposed WT-based waveform reconstruction algorithm. The frequency information of the field waveforms are estimated by the algorithm proposed in [83].

Test A: a harmonic waveform captured from the red-phase input current to a three-phase VSD supplying a submersible water pump. The output voltage of the VSD is set at 20Hz.

Test B: a harmonic waveform captured from the input current of a single-phase LV

final circuit supplying power to an electronic dimmer-controlled lamp bulb, fluorescent luminaries complete with electronic ballasts, a hairdryer and an air compressor motor.

Test A

Fig.6.3 shows two cycles of the field harmonic signal. Fig.6.4 shows the reconstructed fundamental component waveform and the 5th harmonic waveform together with the field harmonic signal.

The reconstructed current waveform at fundamental frequency coincides exactly with the field harmonic waveform in terms of time location and frequency. The proposed reconstruction algorithm is also able to represent the variations in amplitude of the current waveform at fundamental frequency.

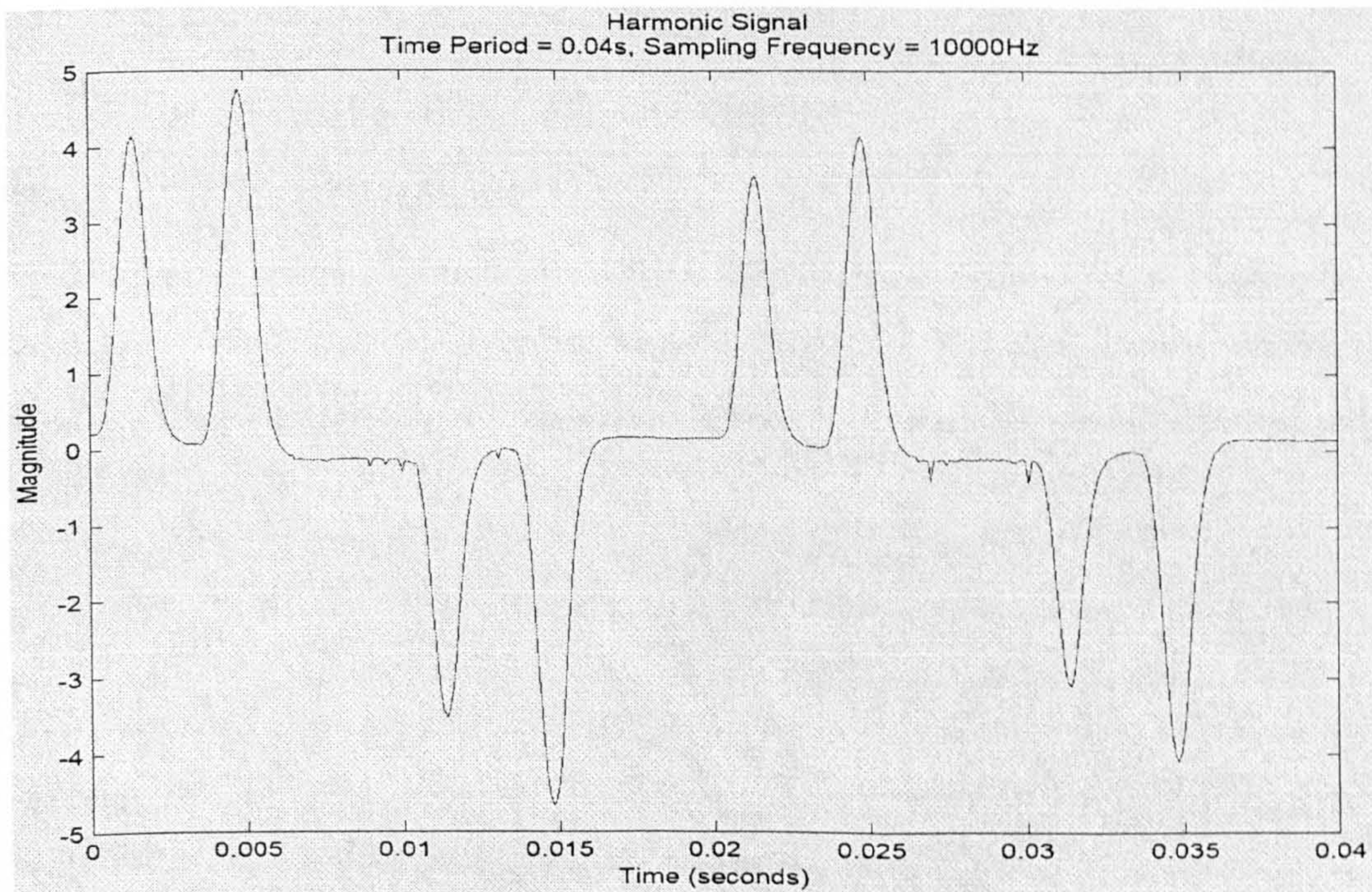

Fig.6.3 Waveform of two cycles of VSD input current

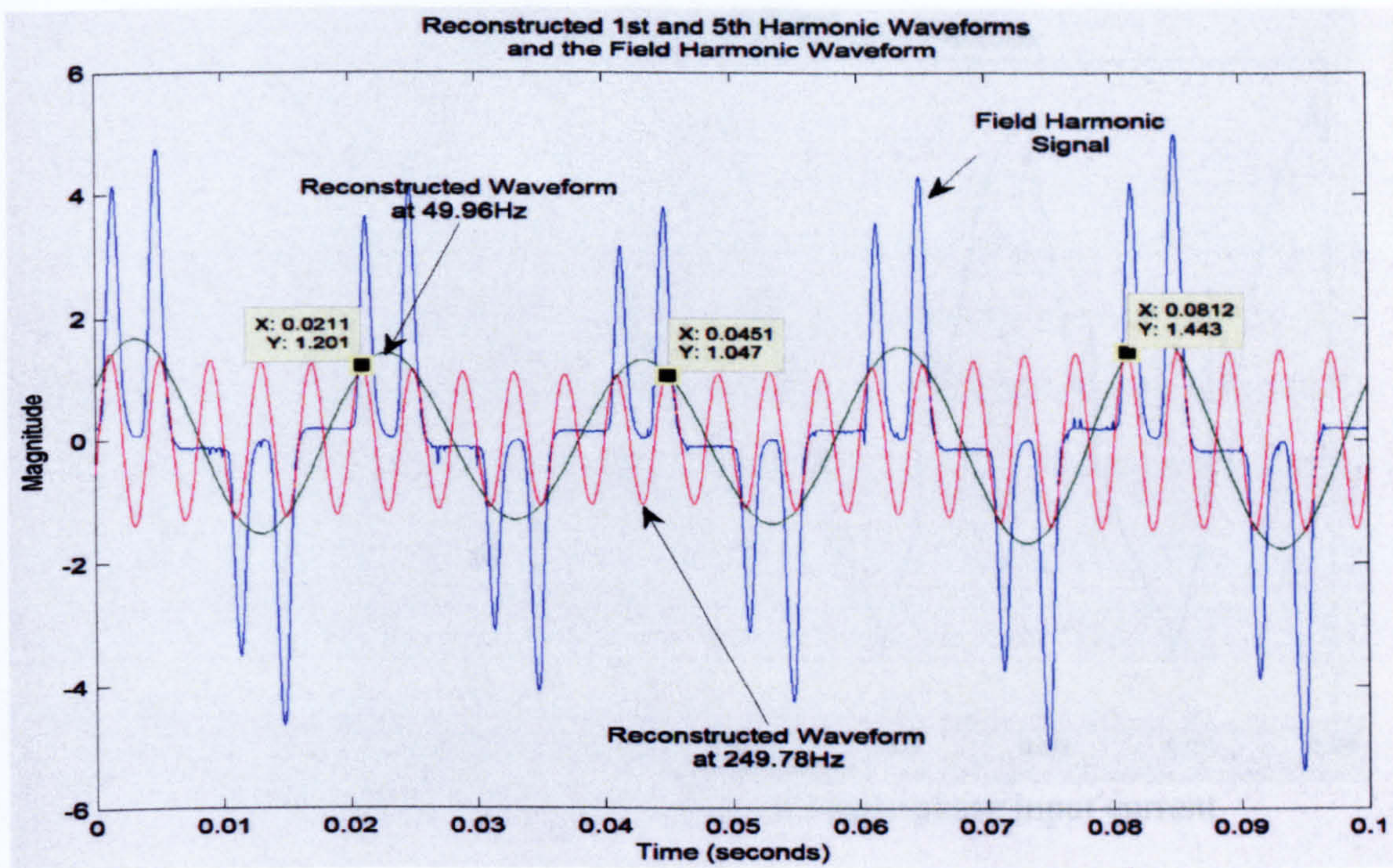

Fig.6.4 Field harmonic signal vs. reconstructed fundamental & 5th harmonic waveform

The reconstructed 5th harmonic waveform coincides with the peaks of the field harmonic waveform. The reconstruction algorithm is also able to represent the variations in amplitude of the 5th harmonic waveform. The proposed reconstruction algorithm can also be used to represent the amplitude variations of other harmonic frequencies.

Test B

Fig.6.5 shows four cycles of the field harmonic signal. Fig.6.6 shows the reconstructed current waveform at fundamental frequency and the 3rd harmonic current waveform together with the field harmonic waveform.

The reconstructed current waveform at fundamental frequency coincides exactly with the field harmonic signal in terms of time location and frequency. The reconstruction algorithm is also able to represent the variations in amplitudes of both the fundamental frequency current waveform and the 3rd harmonic current waveform.

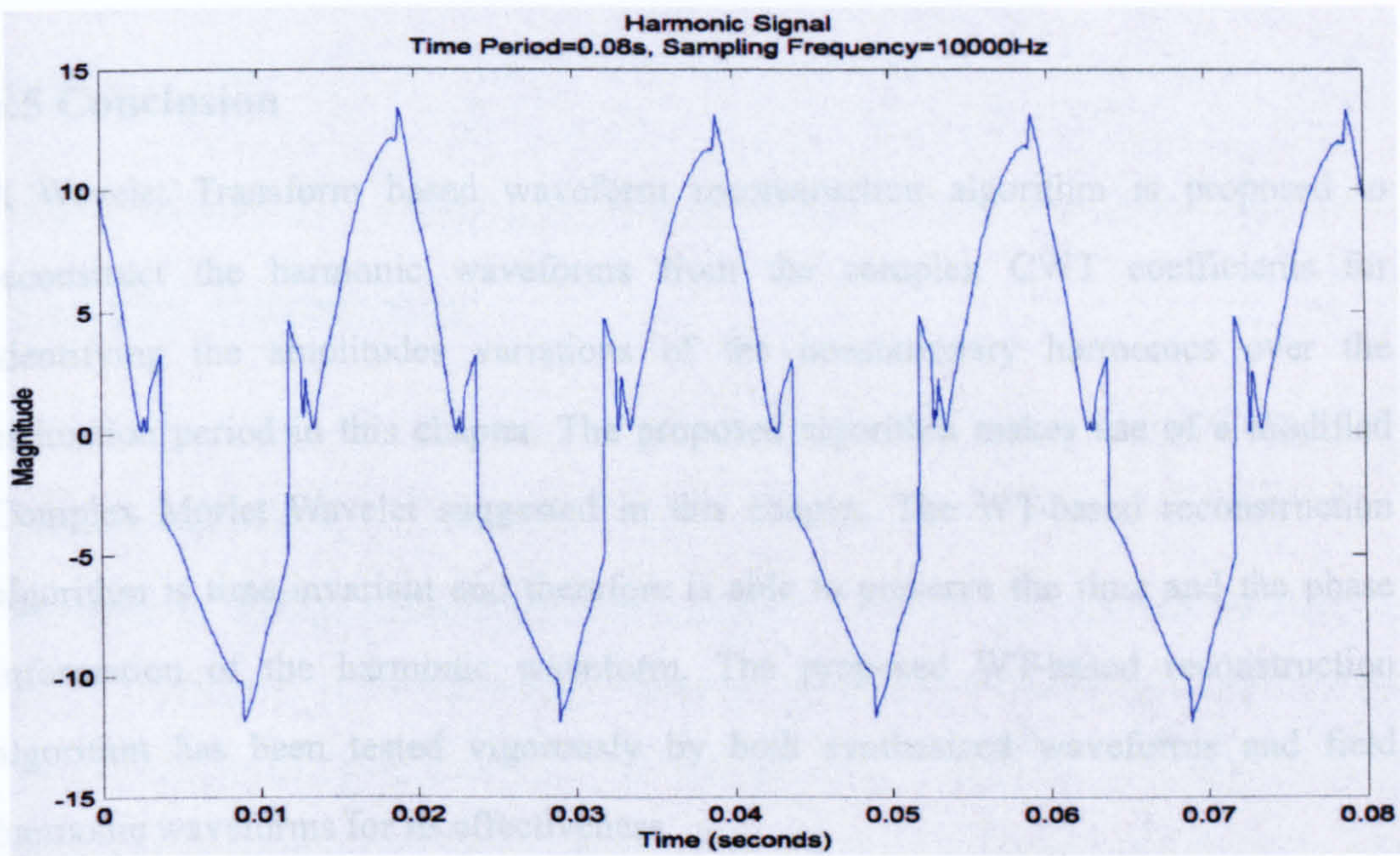

Fig.6.5 Waveform of four cycles of single-phase input current

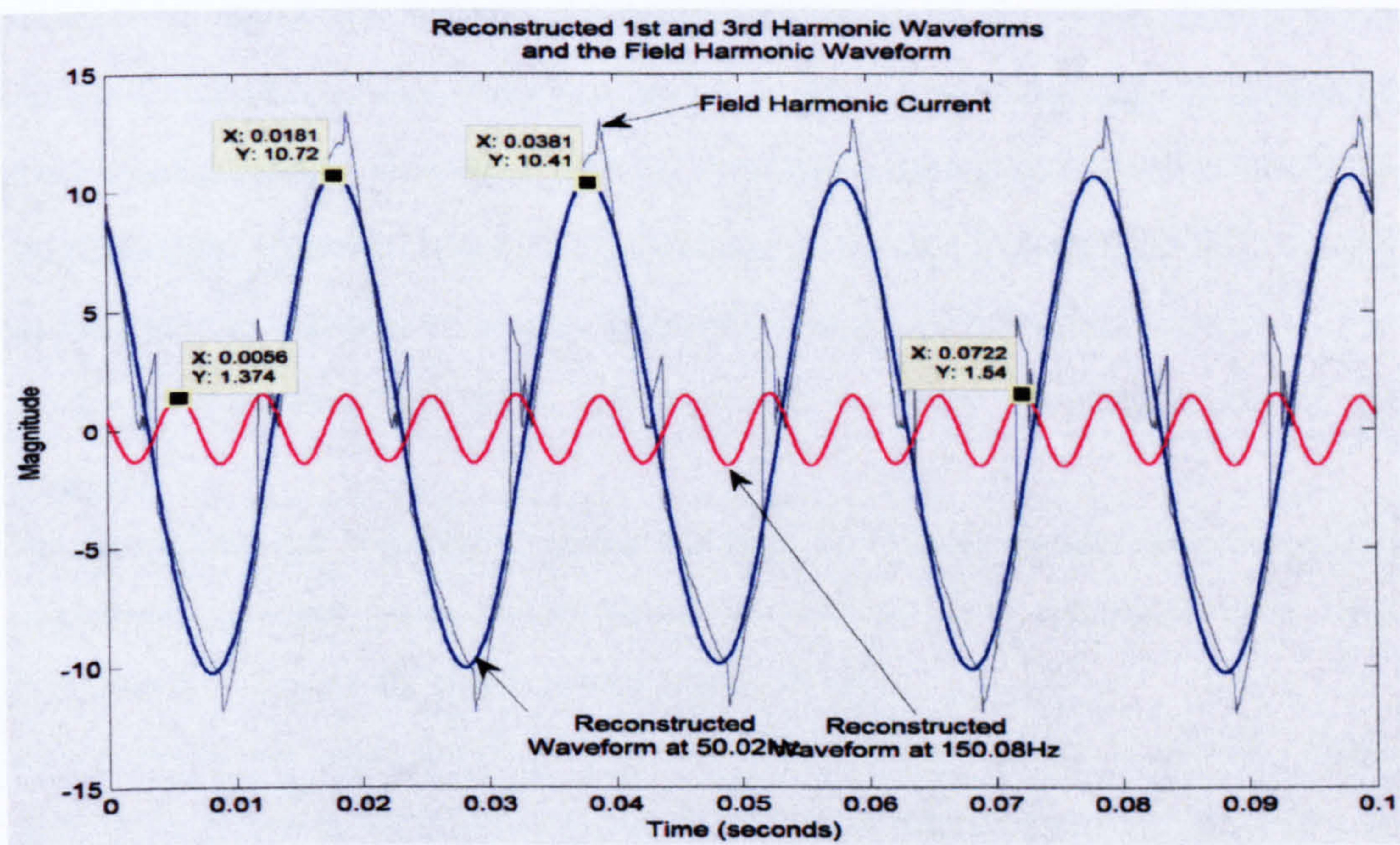

Fig.6.6 Field harmonic signal vs. reconstructed fundamental & 3rd harmonic waveform.

6.5 Conclusion

A Wavelet Transform based waveform reconstruction algorithm is proposed to reconstruct the harmonic waveforms from the complex CWT coefficients for identifying the amplitudes variations of the nonstationary harmonics over the estimation period in this chapter. The proposed algorithm makes use of a modified Complex Morlet Wavelet suggested in this chapter. The WT-based reconstruction algorithm is time-invariant and therefore is able to preserve the time and the phase information of the harmonic waveform. The proposed WT-based reconstruction algorithm has been tested vigorously by both synthesized waveforms and field harmonic waveforms for its effectiveness.

Chapter 7

Detection of Voltage Variations due to Distributed Energy Resources

7.1 Introduction

Detection of voltage variations is very essential for smart grid analysis because the use of distributed renewable energy resources in the smart distribution grid, voltage fluctuations are of rising concerns. This chapter aims to make use of a computational algorithm to identify voltage fluctuations by the use wavelet-based transform. The Continuous Wavelet Transform (CWT) using the Complex Morlet Wavelet (CMW) is adopted to detect the voltage fluctuations presented in a voltage waveform. A modified Complex Morlet Wavelet (CMW) is introduced accordingly. A frequency detection algorithm is developed from the wavelet scalogram and ridges. A waveform reconstruction algorithm based on the Continuous Wavelet Transform (CWT) is used to estimate the variation of voltage amplitudes, locations of voltage sags as well as oscillatory transients. Simulation has been used to verify the effectiveness of the approach.

Power quality has become a major concern for utility, facility and consulting engineers in recent years. International as well as local standards have been formulated to address the power quality issues [85-88].

Power electronic loads drawing harmonic current would induce harmonic voltage drop in the electrical distribution system, thus causing voltage waveform distortion. In IEEE519 [85], it is explicitly stated that the voltage distortion at the Point of Common Coupling (PCC) should not be more than 5%. Nowadays distributed generation is commonly connected to low-voltage electrical distribution system in the form of renewable energy sources. In Hong Kong building integrated Photovoltaic panels (BIPV) are commonly employed in facade of building complex. Given the nature of the BIPV, the output voltage would inevitably vary over time, and the voltage output through an inverter system may contain voltage harmonics as well as dc component.

As previously mentioned, the traditional harmonics analysis method makes use of Fast Fourier Transform (FFT) and Short-Time Fourier Transform (STFT) for analysing power harmonics. It is well known that the FFT and STFT are developed principally for analysing steady waveforms and hence is not very suitable for analysing time-varying voltage variations, such as voltage flicker and oscillatory transients.

This chapter attempts to develop a wavelet-based algorithm to analyse voltage fluctuations including harmonics, voltage amplitude variations and oscillatory transients.

7.2 Wavelet-Based Analysis Algorithm

Wavelet Transform (WT) has been drawing many attentions from scientists and engineers over the years due to its ability to extract signal time and frequency information simultaneously. WT can be continuous or discrete. Continuous Wavelet Transform (CWT) is adopted for harmonic analysis because of its ability to preserve phase information and frequency identification.

As mentioned before, The wavelet transform of a continuous signal, $f(t)$, is defined as [44,72]

$$Wf(u,s) = \langle f, \psi_{u,s} \rangle = \int_{-\infty}^{+\infty} f(t) \frac{1}{\sqrt{s}} \Psi^* \left(\frac{t-u}{s} \right) dt \quad (7.1)$$

where $\psi^*(t)$ is the complex conjugate of the wavelet function $\psi(t)$;

s is the dilation parameter (scale) of the wavelet; and

u is the location parameter of the wavelet.

The wavelet function must satisfy certain mathematical criteria [44]. These are

- a wavelet function must have finite energy; and
- a wavelet function must have a zero mean, i.e., has no zero frequency component.

The modified Complex Morlet Wavelet (CMW) [72,77] is adopted in the algorithm for harmonic analysis, defined as

$$\Psi(t) = \frac{1}{\sqrt{\pi f_b}} e^{-\frac{t^2}{f_b}} e^{j2\pi f_c t} \quad (7.2)$$

where f_b is the bandwidth parameter;

f_c is the centre frequency of the wavelet.

The CMW is essentially a modulated Gaussian function. It is particularly useful for harmonic analysis due to its smoothness and harmonic-like waveform. Because of the analytic nature, CMW is able to separate amplitude and phase information.

It can be easily seen (Fig 5.1) the filter has very good frequency localization at low frequencies. The frequency localization is poorer as the wavelet centre frequency increases.

The definition of the CMW shown in (6.2) is modified slightly, with the scaling factor $1/\sqrt{a}$ changed to $1/a$, as in (5.4) below [40].

$$\varphi\left(\frac{t}{a}\right) = \frac{1}{a} \frac{1}{\sqrt{\pi f_b}} e^{-\frac{(\frac{t}{a})^2}{f_b}} e^{j2\pi f_c \left(\frac{t}{a}\right)} \quad (5.4)$$

The Fourier transform of (5.4) is equal to

$$\Phi(af) = e^{-\pi^2 f_b (af - f_c)^2} \quad (5.5)$$

As previous shown, Fig.5.2 shows the filter banks generated by (5.5), which exhibit the same lobe height for all harmonic frequencies in frequency domain. The time spread and frequency spread of the modified CMW are the same as the original CMW. The importance of the modification to the CMW is that the bandpass filters generated by dilations of the modified mother CMW would have the same lobe height for all

harmonic frequencies. This is useful when the voltage waveform contains harmonics of very small amplitudes compared with the fundamental frequency waveform

The modified CMW described by (5.4) is used for the subsequent analysis.

Wavelet ridges and scalogram are used to identify the frequencies of harmonics and oscillatory transient, as mentioned in [80]. The harmonics amplitudes would be determined easily by

$$A(u) = 2|Wf(u, a)|. \quad (5.6)$$

The values of $A(u)$ are produced in the process of generating the scalogram.

The voltage variations and the oscillatory transient would be identified by the reconstruction algorithm as defined in [89]. It is verified mathematically that for a sinusoidal waveform of sufficient length, the waveform can be fully reconstructed by adding the real part of the corresponding complex CWT coefficients to the imaginary part of the corresponding complex CWT coefficients being shifted backward in time by 90° . Since the reconstruction is time invariant, the instantaneous phase of the harmonic component is preserved in the reconstructed waveform.

7.3 Simulation Settings

An oscillatory transient is a sudden, non-power frequency change in the steady state condition of voltage, current, that includes both positive and negative polarity values.

An oscillatory transient consist of a voltage or current whose instantaneous value changes polarity rapidly. [107] Voltage sag is not a complete interruption of power; it is a temporary drop below 90 percent of the nominal voltage level. Phase angle is a time function. Phase angle in this thesis is a point phase angle. It is not a constant value, it is an instantaneous phase.

Computer generated signals are used to verify the proposed wavelet-based voltage fluctuation detection algorithm. The simulated signal consists of

- a fundamental frequency of 50Hz with an amplitude of 311 volt ;

- the fundamental frequency has a voltage sag of 80% (248.8 volt) from the 4th cycle to 7th cycle.
- a third harmonic with an amplitude of 13 volt
- a fifth harmonic with an amplitude of 7 volt;
- a seventh harmonic with an amplitude of 6 volt;
- an oscillatory transient at the fourth cycle which has a peak value of 405.6 volt and an oscillatory frequency of 2000Hz

The simulated voltage waveform will have a THD of 5%, which is the limit set by IEEE519:1992.

In accordance with the recommendations of BSEN61000-3-14 [48], a time window of 0.2s, corresponding to 10 cycles of waveform at 50Hz would be used. The sampling frequency is set at 6400Hz, measuring up to the 64th harmonics.

The simulated signal is shown in Fig.7.1. The voltage sag appears from data point 386 to 897.

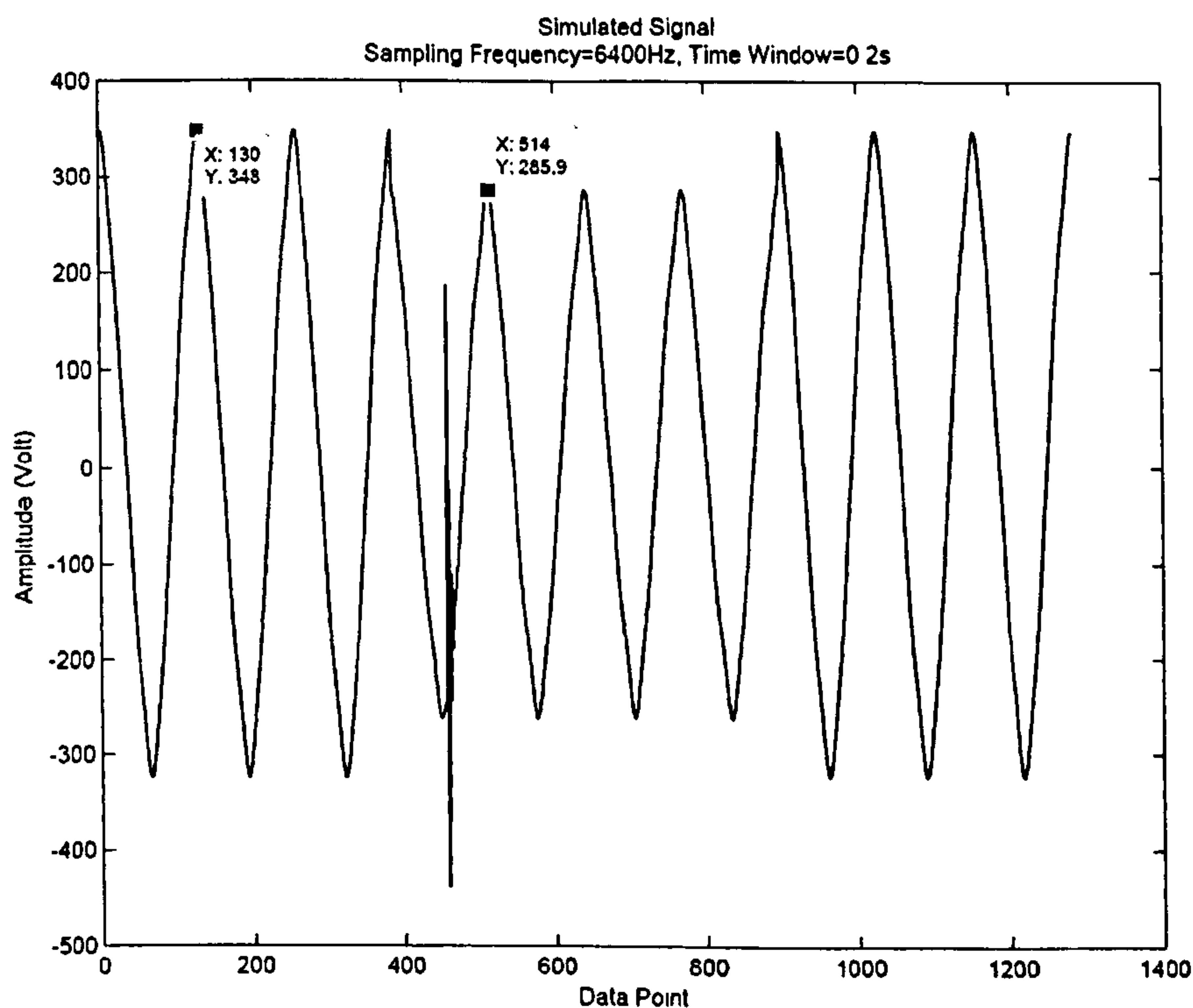

Fig.7.1 Simulated signal.

The oscillatory transient is shown in Fig.7.2. It can be seen that the oscillatory transient appears at data point from 456 to 472. The peak value is 405.6 which appear at data point 457. The oscillatory can be described as

$$f(t) = 600e^{-2000t} \sin(2000(2\pi)t) . \quad (7.3)$$

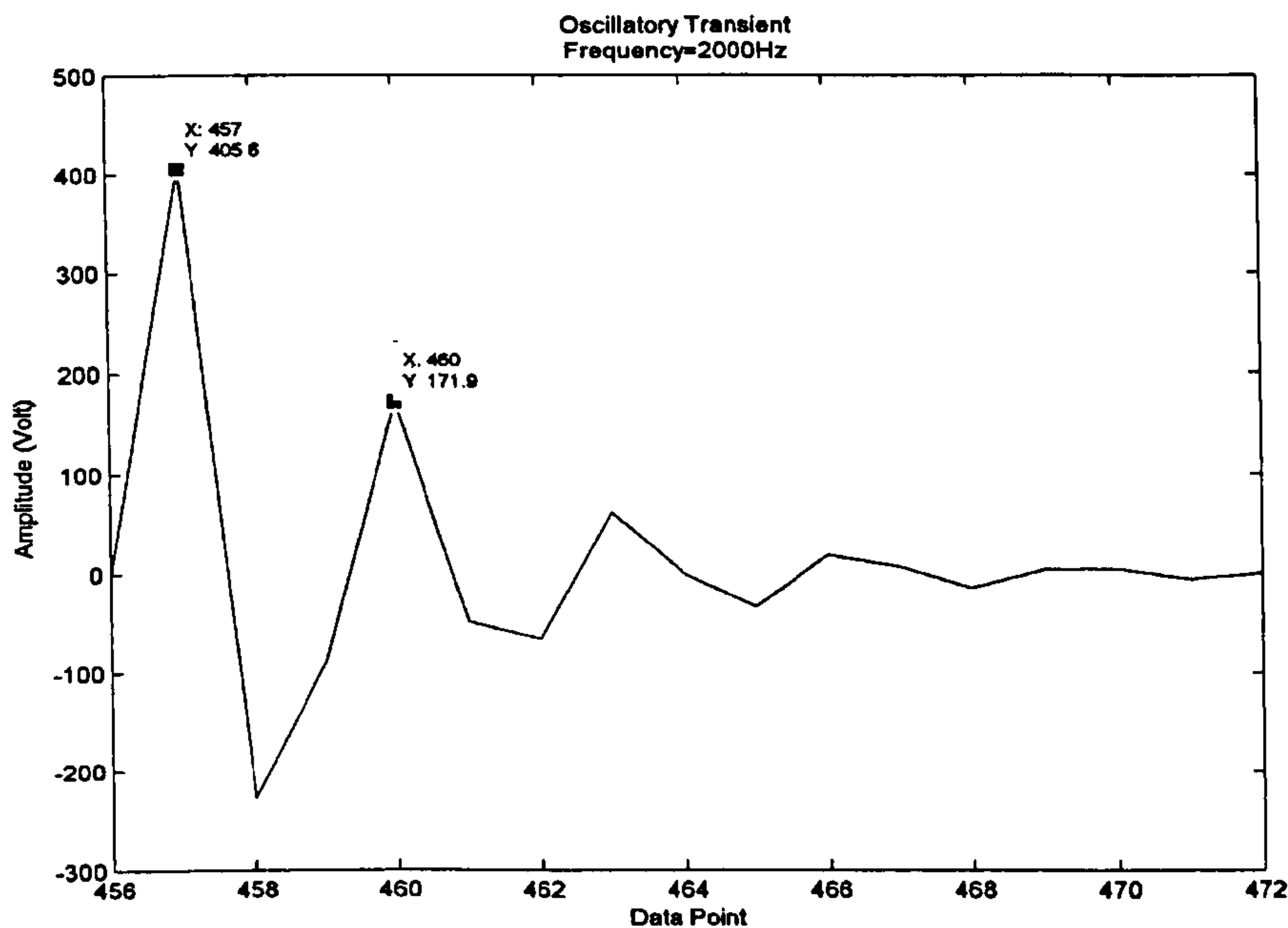

Fig.7.2 Oscillatory transient

7.4 Simulation Results

Based on the method developed in 7.2, the frequency components contained in the simulated signal is identified easily as shown in Fig.7.3. It can be seen that the frequency of the oscillatory transient can also be detected by the proposed algorithm. The amplitudes of the harmonic frequency components are identified in the process of generating the scalogram. Due to the short-time nature of the oscillatory transient, the amplitude estimated is not corresponding to the peak value of the transient.

Wavelet ridge is a frequency to amplitude function. It is very familiar with the spectrum in Fourier Transform. The wavelet ridges are the maxima points of the normalized scalogram. It indicates the instantaneous frequencies within the limits of

the transform's resolution.

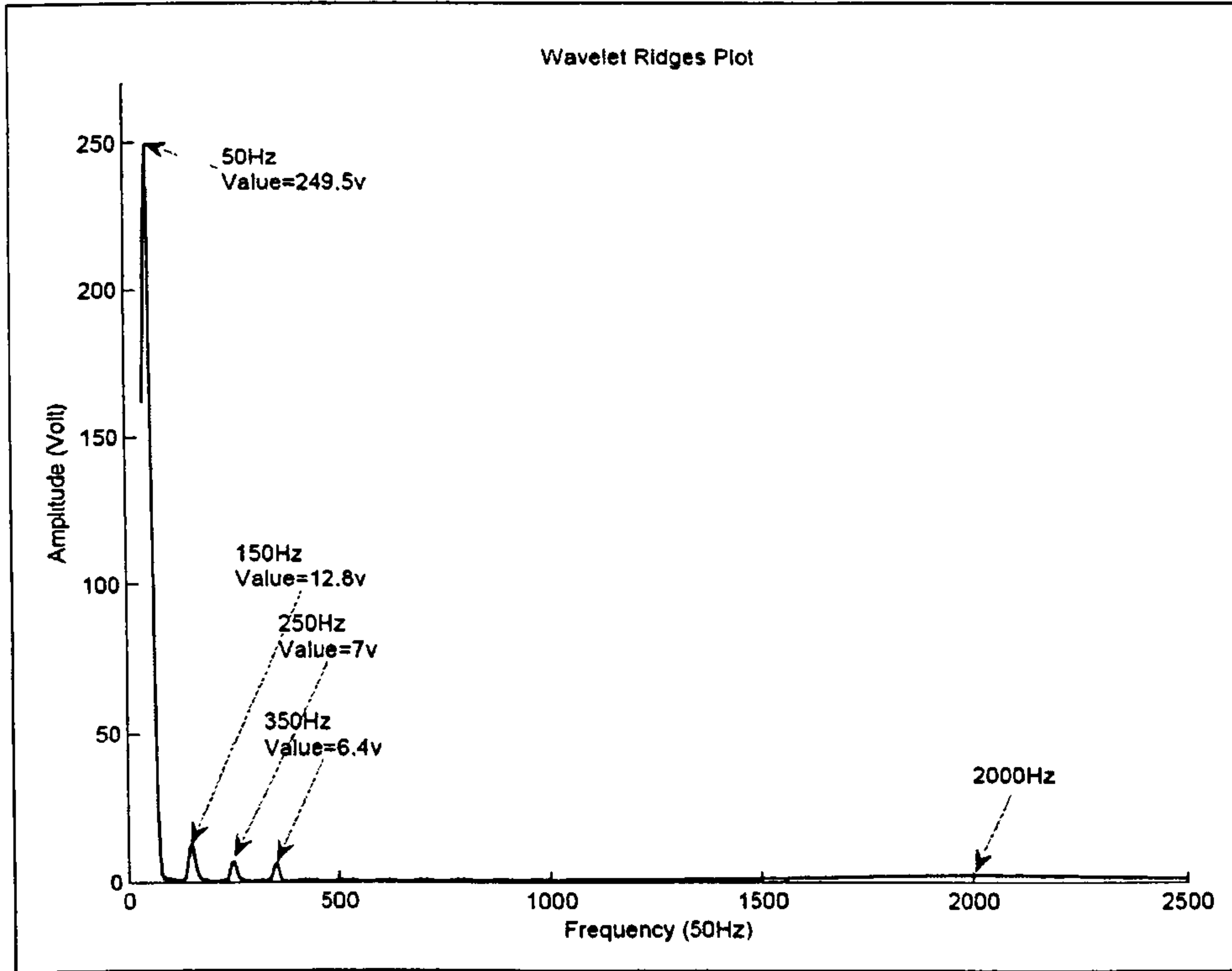

Fig.7.3 Wavelet ridges plot

Table 7.1 below compares the detection results with the simulated values.

Simulated Signal		Detected Results	
Frequency (Hz)	Amplitude (Volt)	Frequency (Hz)	Amplitude (Volt)
Harmonics			
50	311 (248.8 for 4 th to 7 th cycle)	50	249.5
150	13	150	12.8
250	7	250	7
350	6	350	6.4
Oscillatory Transient			
2000Hz	Peak value = 405.6 volt	2000Hz	N. A.

Table.7.1 Comparison of Detection Results

Since in the estimation of harmonic amplitudes, the data in the middle of the analysis window is used, the amplitude estimated for the fundamental frequency is actually the amplitude of the voltage sag.

Based on the reconstruction algorithm in mentioned 7.2, the harmonic waveform would be reconstructed easily. The parameters of the analysing wavelet, i.e. f_b and f_c , are adjusted to $f_b=1$ and $f_c=0.5$ to effect a higher time resolution.

Fig.7.4 shows the reconstructed fundamental waveform. It can be seen that the reconstructed waveform would represent the amplitude variations reasonably accurate.

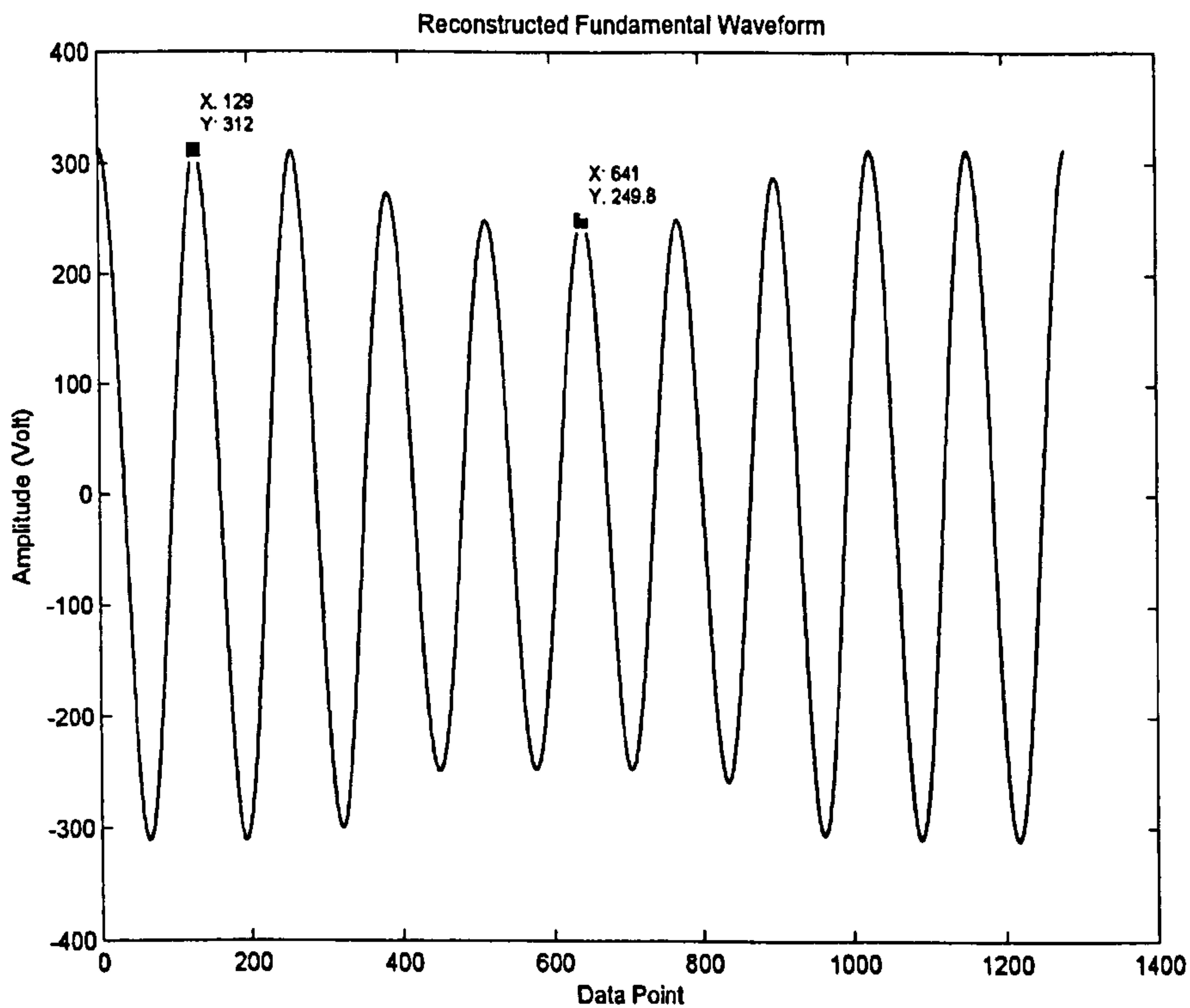

Fig.7.4 Reconstructed fundamental waveform.

With the same reconstruction algorithm, the locations of the peak value of the oscillatory transient and the sudden changes in voltage magnitude due to the voltage sag are identified. Fig.7.5 shows the reconstructed waveform at 2000Hz. Table.7.2 compares the estimated locations with the set locations in the simulated signal.

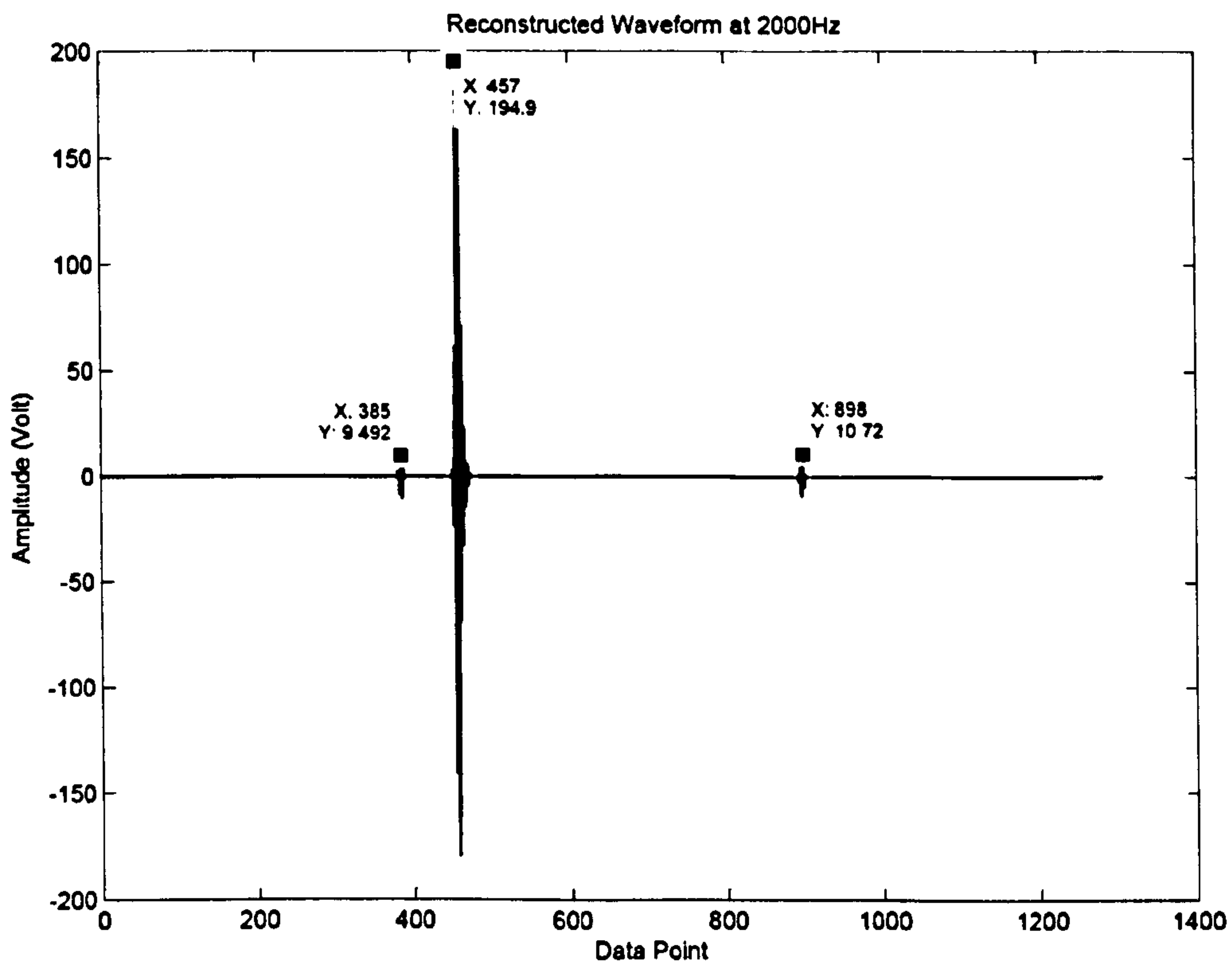

Fig.7.5 Reconstructed waveform at 2000Hz

Simulated Signal	Detected Results
Voltage Sag	
Start Point From data point 385 to 386	Start Point Data point 385
End Point From data point 897 to 898	End Point Data point 898
Oscillatory Transient	
Peak Location Data point 457	Peak Location Data point 457

Table.7.2 Comparison of sudden waveform change locations

It can be seen that the proposed algorithm is able to estimate the locations of sudden changes in waveform accurately.

7.5 Conclusion

This chapter proposed a voltage fluctuation detection algorithm by the use of wavelet-based method is able to identify the exact frequencies and amplitudes of the harmonics in a voltage waveform. The frequency of the oscillatory transient can also be detected accurately. The proposed reconstruction algorithm is able to estimate the voltage variations at fundamental frequency easily. When applying to high frequency, the reconstruction algorithm can also locate sudden changes in waveform as well as the peak transient value.

Chapter 8

Wavelet-GA-ANN Based Hybrid Model for Accurate Prediction of Short-Term Load Forecast

8.1 Introduction

Smart grid being a reality today, which has resulted in competition in every aspect in electricity market; be it in power generation, or in transmission or in energy consumption, professional management of electric energy is of utmost importance. Due to a lot of active network and distributed generation in smart grid the Wavelet-GA-ANN hybrid model is useful for accurate prediction of short-term load forecast. Furthermore, power systems need to operate at even higher efficiency in a deregulated electricity market whereby the generating companies (Gencos) and distribution companies (Discos) have to compete in order to maximize their profits. Accurate prediction of load consumption pattern is becoming very important function to a utility company, as it is needed to support for wiser management decisions. A forecast that exceeds the actual load may lead to extra power being generated and therefore may result in excessive investment in a power plant that is not fully utilized. On the other hand, a forecast that is too low may lead to some revenue loss due to loss of opportunity of selling power to neighboring utilities. Hence, accurate electricity loads forecasting (LF), including very short-term, short-term, mid-term, and long-term, plays a vital role in ensuring adequate electricity generation to meet the customer's demands in the future. LF also helps to build up cost effective risk management plans for the participating companies in the electricity market. Consequently, good operational, planning and intelligent management decision making, such as, economic scheduling of generation capacity, scheduling of fuel purchase, ability to avoid unnecessary start-ups of generating units, planning the scheduling of peaking power, buying or selling electricity at best price, and scheduling of ancillary services, all of them can be carried out based on accurate LF,

which forecasts the load of a few minutes, hours, days, weeks, months ahead. The aim of LF is to predict future electricity demand based on historical load data, and currently available data.

To facilitate accurate load-forecasting analysis, a robust noise filtering and trend analysis algorithm must be used to enable effective eventual automation of the analysis of large volumes of data generated by the monitoring and recording of load consumption readings in any particular system. Currently, several forecasting schemes utilize Artificial Intelligence (AI) methods like ANN and GA to perform load-forecasting tasks. The common problem with such a method is that an AI scheme is only as intelligent as the program that trains it. This in turn depends heavily on the reliability of the training data collected. If such training data were in the first place corrupted by noise, it would mean that pre-processing of such data would be necessary. All these add to the implementation cost and set-up time. A good trend analysis scheme should be able to de-noise the electrical noise inherent in the data, and disregard portions of data where monitoring devices might have failed, giving lower resolution readings as a result of, and be able to take a macro view of the trend while preserving temporal information. The analysis of non stationary signals like load consumption data often involves a compromise between how well important transients can be located and how finely evolutionary behaviors can be detected. Extremely noisy data poses a problem to the operator as how to ascertain the amount of noise in the retained high frequency transient data [90].

The interest in applying neural networks to electric load forecasting began more than a decade ago. Artificial neural networks based methods for forecasting have shown ability to give better ability in dealing with the nonlinearity and other difficulties in modeling of the time series data. ANNs have been applied recently in the area of time-series forecasting due to their flexibilities in data modeling [91,92]. Most of the approaches reported since are based on the use of an MLP network as an approximator of an unknown nonlinear relation. There have been some pioneering works on applying wavelet techniques together with ANN to time series forecasting, [93-97]. Among ANN based forecasting methods, Radial Basis Function (RBF)

networks have been widely used primarily because of their simple construction and easier training is as compared to Multi-layer Perceptrons (MLPs) in addition to their capability in inferring the hidden relationship between input and desired target patterns. This capability is attributed to its property that it can approximate any continuous function to any degree of accuracy by constructing localized radial basis functions. From the standpoint of preserving characteristics of different classes, this local approximation approach has the advantage over the global approximation approach of multi-layer perception networks.

As large amounts of historical load patterns are needed in a typical load-forecasting algorithm, even low sampling rates of 1 sample per minute generates a huge amount of data. Hence, the effective compression of large data and faithful reconstruction of original signal from compressed data is a major challenge for time series data. Also, when an ANN, especially RBF network, is trained with huge data (with noise), it may result into not only a big network model and very time consuming training but also that the network may fail to capture the true features in the data. With the development of wavelet transforms, the difficulty of effective data compression and faithful retrieval of original data can be well tackled. This tempted researchers to try RBF networks model combined with wavelet transformed data for capturing useful information on various time scales. These strategies approximate a time-series at different levels of resolution using multi-resolution decomposition. Recent works [98] stresses on the use of shift invariant wavelet transforms, which is an auto correlation shell representation technique, for making the analysis of time series data easier. This technique is employed to reconstruct signals after wavelet decomposition. With the help of this technique, a time series can be expressed as an additive combination of the wavelet coefficients at different resolution levels. These data are then applied to build Neural-Wavelet based forecasting models to predict electricity demand as from the data obtained from a real electricity market.

Autocorrelation shell representation base wavelet transform is used to approximate Short-term Load Forecast (STLF) at different levels of resolution using multi-resolution decomposition. This decomposed data is used for training the RBF

network for predicting the wavelet coefficients of future loads. RBF networks optimized with the help of FPGA (Floating Point Genetic Algorithm). This technique is then applied to build Neural-Wavelet based forecasting models to predict electricity demand as from the data obtained from a real electricity market.

8.2 Wavelet Transforms in Load Forecast

Wavelet transforms [99, 100] though known previously has gained much attention only recently. It has been exploited in many fields like seismic studies, image compression, signal processing processes and mechanical vibrations. The flexible time-scale representations of wavelet transform has found its place in many applications that traditionally used modified forms of Fourier Transforms (FT) like Short Time FT (STFT) and the Gabor Transforms. Its impressive temporal content and frequency isolation features have tempted researchers to use them in the area of power systems analysis.

Wavelet transforms provide a useful decomposition of a signal, or time series, so that faint temporal structures can be revealed and handled by nonparametric models. They have been used effectively for image compression, noise removal, object detection, and large-scale structure analysis, among other applications.

8.2.1 Time series and wavelet decomposition in load forecasting

The continuous wavelet transform of a continuous function produces a continuum of scales as output. On the other hand, input data is usually discretely sampled, and furthermore a dyadic or two-fold relationship between resolution scales is both practical and adequate. The latter two issues lead to the discrete transform. Fig.8.1 shows the wavelet decomposition.

Wavelet decomposition provides a way of analyzing a signal in both time and frequency domains. For a suitably chosen mother wavelet function ψ a function f can be expanded as:

$$f(t) = \sum_{j=-\infty}^{\infty} \sum_{k=-\infty}^{\infty} w_{jk} 2^{j/2} \varphi(2^j t - k) \quad (8.1)$$

where the functions $\psi(2^j t - k)$ are all orthogonal to each other. The coefficients w_{jk} gives information about the behavior of the function f concentrating on the effects of scale around 2^{-j} near time $t \times 2^{-j}$. This wavelet decomposition of a function is closely related to a similar decomposition (the discrete wavelet transform, DWT) of a signal observed in discrete time.

It is well known that DWT has many advantages in compressing a wide range of signals observed in the real world. However, in time series analysis, DWT often suffers from a lack of translation invariance. This means that DWT based statistical estimators are sensitive to the choice of origin. The output of a discrete wavelet transform can take various forms [101]. Traditionally, a triangle (or pyramid in the case of 2-dimensional images) is often used to represent all that is worth considering in the sequence of resolution scales. Such a triangle comes about as a result of decimation or the retaining of one sample out of every two. The major advantage of decimation is that just enough information is retained to allow exact reconstruction of the input data. Therefore decimation is ideal for effective compression. However, it can be easily shown that the storage required for the wavelet-transformed data is exactly the same as is required by the input data. The computation time for many wavelet transform methods is also linear in the size of the input data, i.e. $O(n)$ or n -length input time series. Also, with the decimated form of output it is less easy to visually or graphically relate information at a given time point at different scales. More problematic is their lack of shift invariance. This means that if the last few values of the input time series are deleted, then the wavelet transformed, decimated output data will be quite different from heretofore. One way to solve this problem at the expense of greater storage requirements is by means of a redundant or non-decimated wavelet transform.

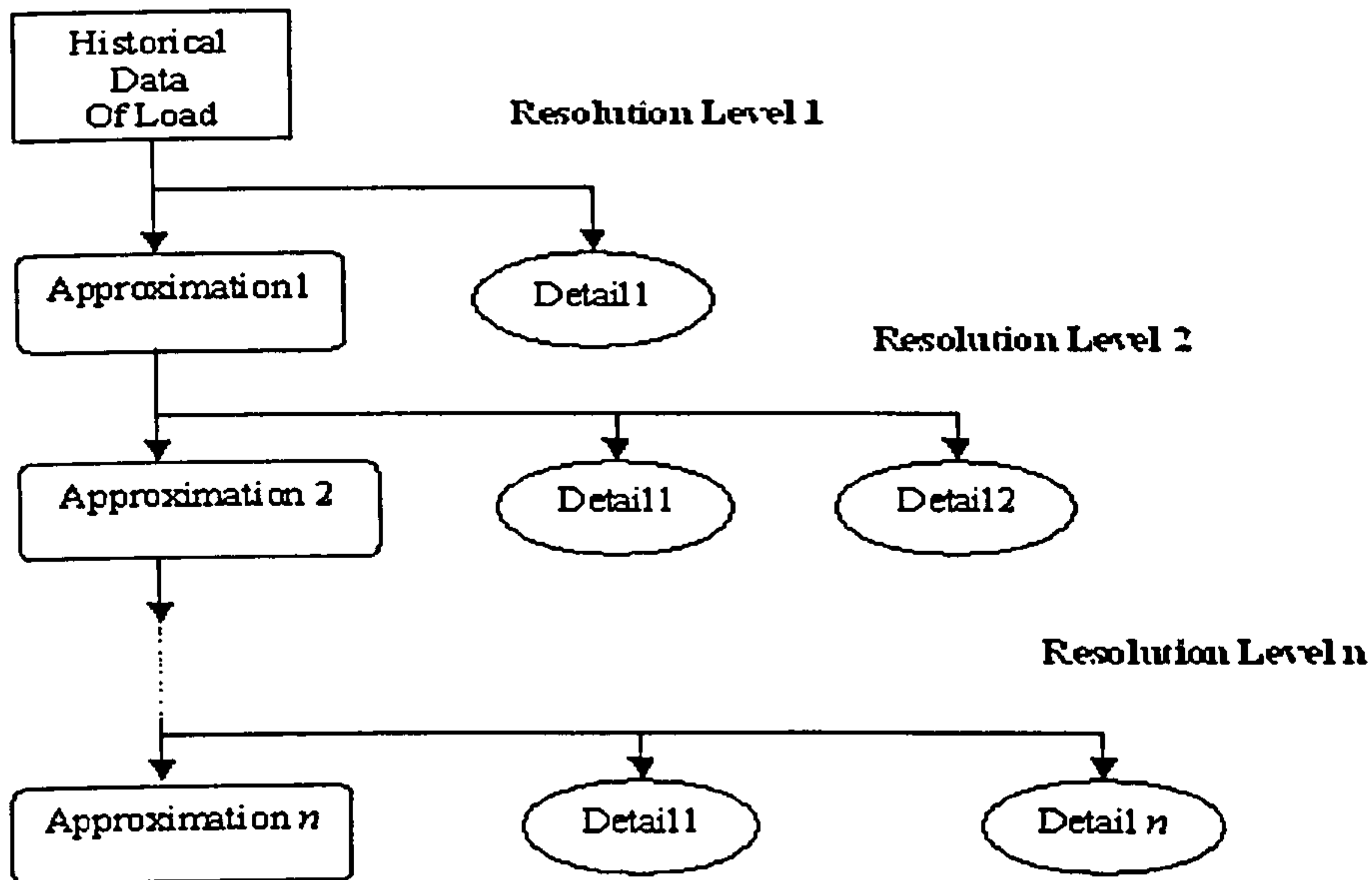

Fig.8.1 Wavelet Decomposition Process

A non-decimated wavelet transform based on an n -length input time series, then, has an n -length resolution scale for each of the resolution levels of interest. Therefore, information at each resolution scale is directly related at each time point. This results in shift invariance. Finally, the extra storage requirement is by no means excessive. An *à trous* algorithm is used to realize the shift-invariant wavelet transforms. Such transforms are based on the so-called auto-correlation shell representation [98] by dilations and translations of the auto-correlation functions of compactly supported wavelets.

By definition, the auto-correlation functions of a compactly supported scaling function $\phi(x)$ and the corresponding wavelet $\psi(x)$ are as follows:

$$\begin{aligned}\phi(x) &= \int_{-\infty}^{\infty} \phi(y)\phi(y-x)dy \\ \psi(x) &= \int_{-\infty}^{\infty} \psi(y)\psi(y-x)dy\end{aligned}\tag{8.2}$$

The set of functions $\{\bar{\psi}_{j,k}(x)\}_{1 \leq j \leq n_0, 0 \leq k \leq N-1}$ and $\{\bar{\phi}_{n_0,k}(x)\}_{0 \leq k \leq N-1}$ is called an auto correlation shell, where:

$$\begin{aligned}\bar{\psi}_{j,k}(x) &= 2^{-j/2} \psi(2^{-j}(x-k)) \\ \bar{\phi}_{n_0,k}(x) &= 2^{-n_0/2} \phi(2^{-n_0/2}(x-k))\end{aligned}\tag{8.3}$$

A set of filters $P = \{p_k\}_{-L+1 \leq k \leq L-1}$ and $Q = \{q_k\}_{-L+1 \leq k \leq L-1}$ can be defined as:

$$\begin{aligned}\frac{1}{\sqrt{2}} \phi\left(\frac{x}{2}\right) &= \sum_{k=-L+1}^{L-1} p_k \phi(x-k) \\ \frac{1}{\sqrt{2}} \psi\left(\frac{x}{2}\right) &= \sum_{k=-L+1}^{L-1} q_k \phi(x-k)\end{aligned}\tag{8.4}$$

Using the filters P and Q, the pyramid algorithm for expanding into the auto-correlation shell can be obtained as:

$$c_j(k) = \sum_{l=-L+1}^{L-1} p_l c_{j-1}(k + 2^{j-1}l)\tag{8.5}$$

$$w_j(k) = \sum_{l=-L+1}^{L-1} q_l c_{j-1}(k + 2^{j-1}l)\tag{8.6}$$

These shell coefficients obtained from (8.5) and (8.6) can then be used to directly reconstruct the signals. Given smoothed signal at two consecutive resolution levels, the detailed signal can be derived as:

$$w_j(k) = \sqrt{2}c_{j-1}(k) - c_j(k)\tag{8.7}$$

The process of generating wavelet coefficient series is further illustrated with the block diagram as shown in Fig.8.2.

Then the original signal $c_0(k)$ can be reconstructed from the coefficients

$$\left\{w_j(k)\right\}_{1 \leq j \leq n_0, 0 \leq k \leq N-1} \quad \text{and} \quad \text{residual} \quad \left\{c_{n_0}(k)\right\}_{0 \leq k \leq N-1} :$$

$$c_0(k) = 2^{-n_0/2} c_{n_0}(k) + \sum_{j=1}^{n_0} 2^{-j/2} w_j(k)\tag{8.8}$$

for $k=0, \dots, N-1$, where $c_{n_0}(k)$ is the final smoothed signal.

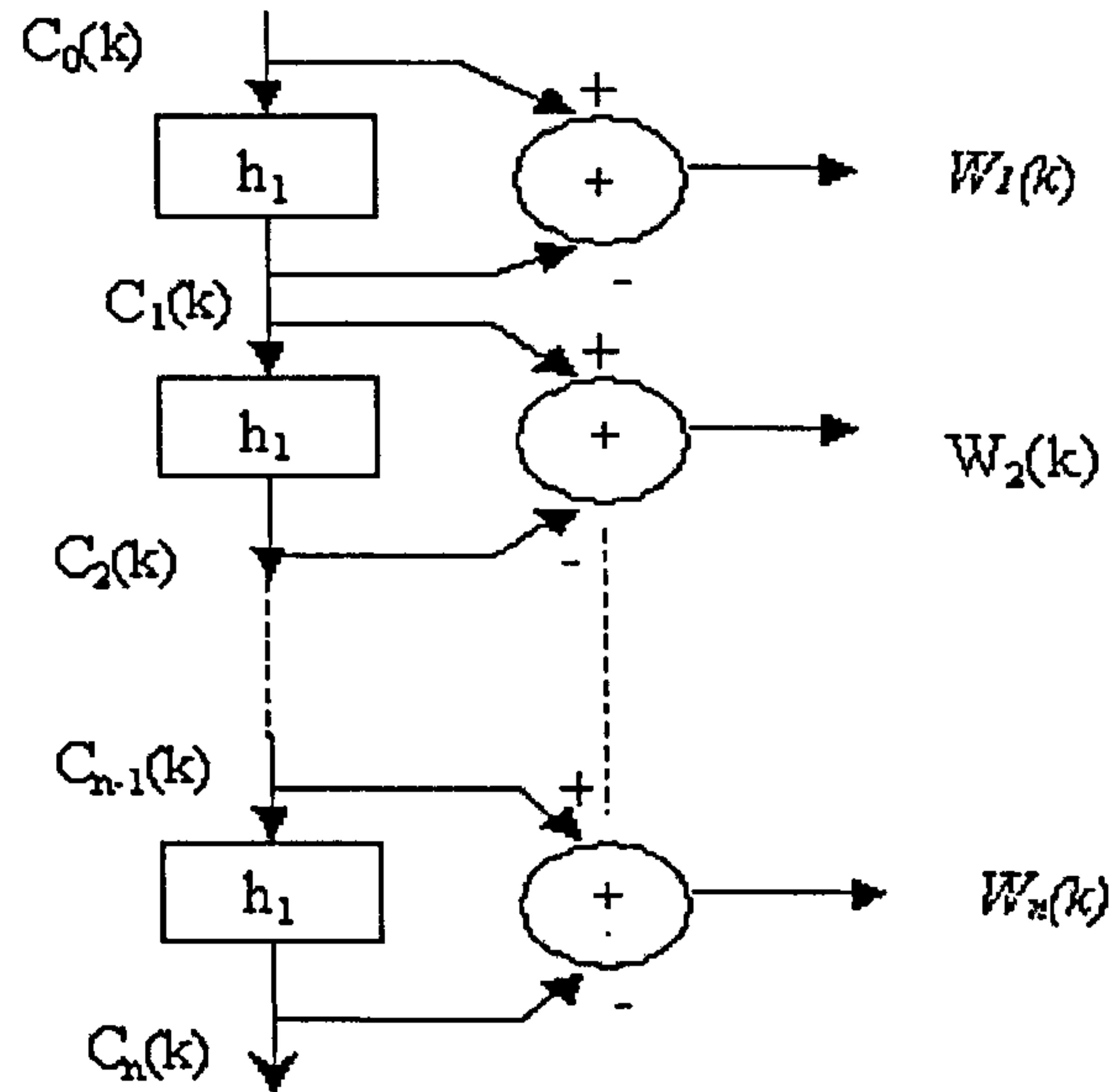

Fig.8.2. Wavelet Transform of a Time-Series Signal

To make more precise predictions the most recent data shall be used. In case of adaptive learning, the previous data is penalized with forgetting factors. The time-based à tours filters similar to that of are used to deal with the boundary condition. Fig.8.3 shows the wavelet recombination process.

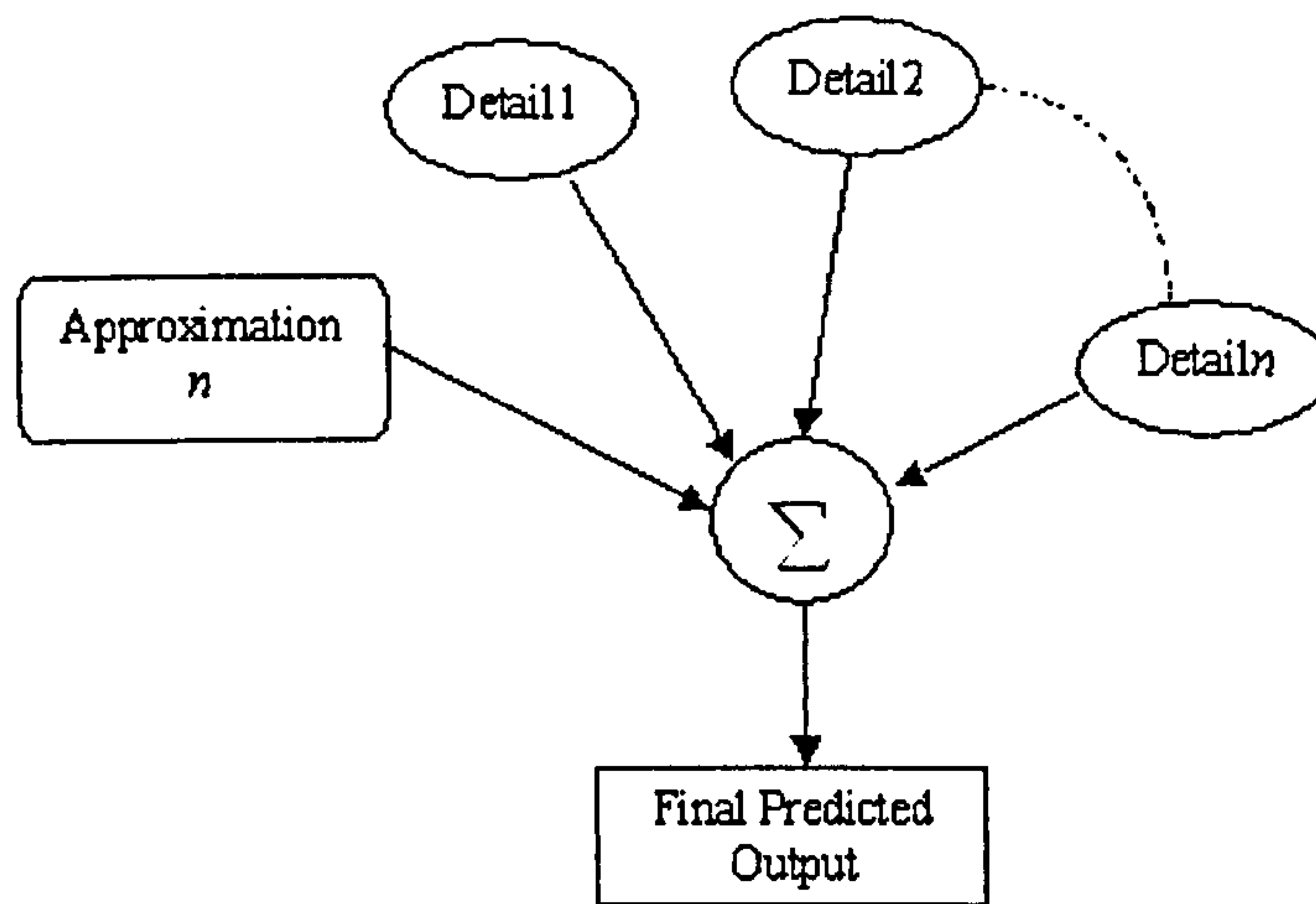

Fig.8.3 Wavelet Recombination Process

8.3 Radial Basis Networks

An RBF is a function which has in-built distance criterion with respect to a center [102]. A typical RBF neural network consists of three layers (input, hidden, output).

The activation of a hidden neuron is determined in two steps: The first is to compute the distance (usually the Euclidean norm) between the input vector and a center c_i that represents its hidden neuron; second, a function, that is usually bell shaped, is applied, using the obtained distance to get the final activation of the hidden neuron. In the present case the well known Gaussian function $G(x)$ is used.

$$G(x) = \exp\left(-\frac{\|x - c_i\|^2}{2\sigma^2}\right) \quad (8.9)$$

The parameter σ is called unit width (spread factor) and is determined using the GA. All the widths in the network are fixed to the same value and these results in a simpler training strategy. The activation of a neuron in the output layer is determined by a linear combination of the fixed nonlinear basis functions, i.e.

$$F(x) = w_0 + \sum_{i=1}^M w_i \phi_i(x) \quad (8.10)$$

where $\phi_i(x) = G(\|x - c_i\|)$ and w_i are the adjustable weights that link the output nodes with the appropriate hidden neurons and w_0 is the bias weight. These weights in the output layer can then be learnt using the least-squares method.

The present work adopts a systematic approach to the problem of centre selection. Because a fixed center corresponds to a given regressor in a linear regression model, the selection of RBF centers can be regarded as a problem of subset selection. The orthogonal least squares (OLS) method [103] can be employed as a forward selection procedure that constructs RBF networks in a rational way. The algorithm chooses appropriate RBF centers one by one from training data points until a satisfactory network is obtained. Each selected centre minimizes the increment to the explained variance of the desired output, and so ill-conditioned problems occurring frequently in random selection of centers can automatically be avoided. In contrast to most learning algorithms, which can only work if a fixed network structure has first been specified, the OLS algorithm is a structural identification technique, where the centers and

estimates of the corresponding weights can be simultaneously determined in a very efficient manner during learning. OLS learning procedure generally produces an RBF network smaller than a randomly selected RBF network. Due to its linear computational procedure at the output layer, the RBF is shorter in training time compared to its back propagation counter part.

A major drawback of this method is associated with the input space dimensionality. For large numbers of inputs units, the number of radial basis functions required, can become excessive. If too many centers are used, the large number of parameters available in the regression procedure will cause the network to be over sensitive to the details of the particular training set and result in poor generalization performance (overfit).

The present work uses a floating point GA based algorithm for optimizing the centers and spread factors.

8.3.1 A hybrid Neural-Wavelet model for short-term load prediction

The proposed hybrid neural-wavelet model for short-term load prediction is shown in Fig.8.4. Given the time series $f(n)$, $n=1, \dots, N$, the aim is to predict the l -th sample ahead, $f(N+l)$, of the series. As a special case, $l=1$ stands for single step prediction. For each value of l separate prediction architecture is trained accordingly. The hybrid scheme basically involves three stages [93]. At the first stage, the time series is decomposed into different scales by autocorrelation shell decomposition; at the second stage, each scale is predicted by a separate RBF network; and at the third stage, the next sample of the original time series is predicted by another RBF network using the different scale's prediction.

For time series prediction, correctly handling the temporal aspect of data is one of the primary concerns. The time-based \hat{a} trous transform as described above provides a simple but robust approach. Here we introduce an \hat{a} trous wavelet transform based on the autocorrelation shell representation for the prediction model usage. This approach is realized by applying (8.7) and (8.8) to successive values of t . As an

example, given an electricity demand series of 1008 values, we hope to extrapolate into the future with 1 or more than 1 subsequent value. By the time-based \hat{a} trous transform, we simply carry out a wavelet transform on values x_1-x_{1008} . The last values of the wavelet coefficients at time-point $t=1008$ are kept because they are the most critical values for forecasting system. w_1, \dots, w_k are wavelet coefficients, c is the residual coefficient series.

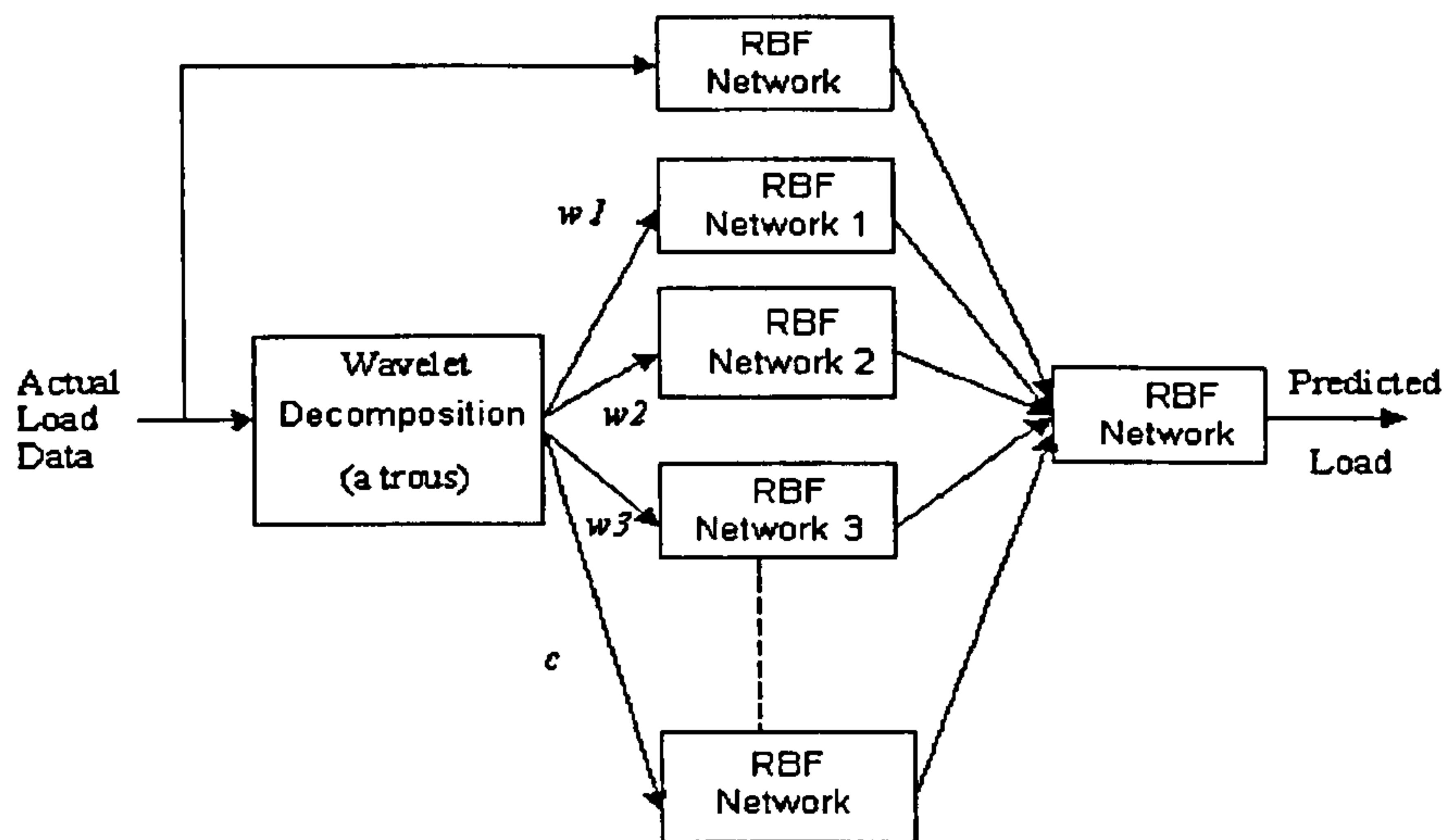

Fig.8.4 Overview of the neural-wavelet multiresolution forecasting system. w_1, \dots, w_k are wavelet coefficients, c is the residual coefficient series

Repeat the same procedure at time point $t=1009, 1010\dots$ repeatedly. It empirically determines the number of resolution levels J , mainly depending on the inspection of smoothness of the residual series for a given J . Much of the high-resolution coefficients are noisy. Prior to forecasting, we get an over complete, transformed dataset.

In Fig.8.5, it shows the behavior of the four-wavelet coefficients over 1008 points for a load series. Note that the data have been normalized for wavelet analysis. Normalization of data is an important stage, for training the neural network. The normalization of data not only facilitates the training process but also helps in shaping the activation function. It should be done such that the higher values should not suppress the influence of lower values and the symmetry of the activation function is

retained. The input load data is normalized between the minimum value, -1 and the maximum value, +1 by using the formula.

$$\left(\frac{\text{Actualvalue} - \text{Minimum}}{\text{Maximum} - \text{Minimum}} \right) \times (\text{Maximum} - \text{Minimum}) + \text{Minimum} \quad (8.11)$$

The load data should be normalized to the same range of values. The original time series and residual are plotted at the top and bottom in the same figure, respectively. As the wavelet level increases, the corresponding coefficients become smoother. As we will discuss in the next section, the ability of the network to capture dynamical behavior varies with the resolution level.

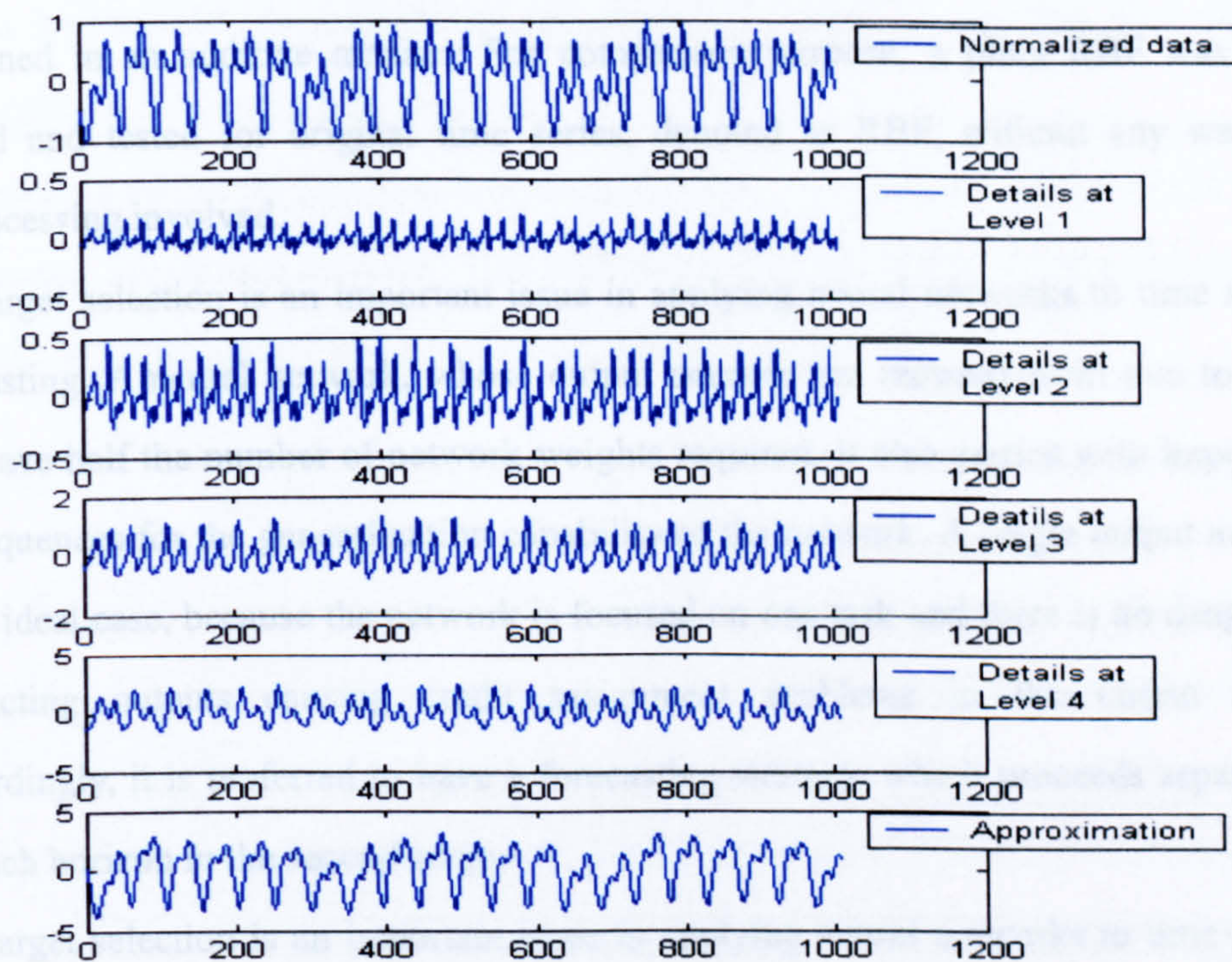

Fig.8.5 Illustrations of the trous wavelet decomposition of a series of electricity demand

At the second stage, a predictor is allocated for each resolution level and the following wavelet's coefficients $w_i^j(t); j=0, \dots, J; i=1, \dots, N$ are used to train the predictor. All networks used to predict the wavelets' coefficients of each scale are of similar feed forward RBF perceptrons with D input units, one hidden layer with radial basis function as an activation function, and one linear output neuron. Each unit in the networks has an adjustable bias. The D inputs to the j -th network are the previous

samples of the wavelets' coefficients of the j -th scale. In the proposed model implementation, each network is trained by the orthogonal least squares (OLS) method, which can be employed as a forward selection procedure that constructs RBF networks in a rational way. The procedure for designing neural network structure essentially involves selecting the input, hidden and output layers. At the third stage, the predicted results of all the different scales $\hat{w}_{N+i}^j(t)$, $j=0,\dots,J$ are appropriately combined. Here we discussed and compared three methods of combination. In the first method, we simply applied the linear additive reconstruction property of the à trous, see (8.6). The fact that the reconstruction is additive allows the predictions to be combined in an additive manner. For comparison purpose, a plain RBF was also trained and tested for original time series, denoted as RBF, without any wavelet preprocessing involved.

The target selection is an important issue in applying neural networks to time series forecasting. A neural network, whose output neurons are reduced from two to one, will have half the number of network weights required. It also carries with important consequences for the generalization capability of the network. A single output neuron is the ideal case, because the network is focused on one task and there is no danger of conflicting outputs causing credit assignment problems in the output layer. Accordingly, it is preferred to have a forecasting strategy, which proceeds separately for each horizon in the second stage.

The target selection is an important issue in applying neural networks to time series forecasting. A neural network, whose output neurons are reduced from two to one, will have half the number of network weights required. It also carries with important consequences for the generalization capability of the network. A single output neuron is the ideal case, because the network is focused on one task and there is no danger of conflicting outputs causing credit assignment problems in the output layer. Accordingly, it is preferred to have a forecasting strategy, which proceeds separately for each horizon in the second stage.

8.4 Experimental Results

The proposed model is tested with two sets of historical data containing the electricity load for the month of July 2005 and month of July 2006, on a half-hourly basis; both sets of electricity load data of Queensland. The sets of electricity load data are downloaded from the NEMMCO website [104].

The simulation results are obtained through the use of four different programs. These programs were written in MATLAB command line in association with MATLAB toolboxes on wavelet, and neural network. Programs are run in a PC of Pentium IV, 256 MB RAM, 3.2 GHz.

Before the wavelet decomposition technique (à trous) is applied, the sets of historical load data are first normalized.

The model is evaluated based on its prediction errors. A successful model would yield an accurate time-series forecast. The performance of the model is hence measured using the absolute percentage error (APE), which is defined as

$$APE = \left(\frac{|x_i - y_i|}{x_i} \right) \times 100 \quad (8.12)$$

where x_i is the actual values and y_i is the predicted values at time instance i . This error measure is more meaningfully represented as an average and standard deviation (S.D.) over the forecasting range of interests. Additional measure of the error is defined from the cumulative distribution function as the 90th percentile of the absolute percentage error, which provides an indication of the behavior of the tail of the distribution of errors and indicates that only 10% of the errors exceed this value.

The forecasting results from the different forecasting schemes are presented in Table.8.1. The RBF network is optimized using FPGA in terms of number of inputs, centers, and spread factor. The number of neurons in the hidden layer is auto-configured by the OLS algorithm. The Table.8.1 shows that the à trous wavelet transform system with adaptive combination coefficients for summing up the wavelet coefficients forecasting, is the best in seven step ahead forecasting for the testing data, with regards to the mean, variance and percentile over the absolute percentage error

(APE).

Parameters for FPGA algorithm:

Population Size = 40

Maximum Iterations = 30

Operators for FPGA:

1. Heuristic crossover
2. Uniform mutation
3. Normalized geometric select function

Scheme Number	1	2	3	4	5	6	7
μ_R	5.00	5.11	5.66	6.14	6.73	7.20	7.85
σ^2_R	0.7	1.1	1.6	2.3	2.9	3.6	3.4
η_R	0.086	0.093	0.107	0.123	0.138	0.150	0.156
μ_w	1.43	1.13	1.19	1.53	2.22	1.55	1.14
σ^2_w	0.057	.0662	0.052	0.065	0.083	0.183	0.175
η_w	0.024	0.0216	0.022	0.025	0.033	0.036	0.034

Table.8.1 Load forecast performance on testing data on APE measure for FPGA optimized spread factor and input

$\sigma^2_R \times 10^{-3}$, $\sigma^2_w \times 10^{-3}$ are the spread factors and subscript R refers to the results with only RBF networks while subscript w refers to the results with hybrid wavelet-RBF model.

8.5 Conclusion

This chapter has demonstrated the use of wavelet techniques and its integration with neural networks for power quality analysis & assessment and load forecasting. Under the electricity deregulated environment, it is important to have innovation in engineering so that power system will operate in a much more cost effective, reliable and secure way. This Chapter has demonstrated some of the techniques that have a high potential to be used in the near future for real-life applications.

Chapter 9

Conclusions and Future work

9.1 Overall conclusion

Smart grid will be the next generation power grid. Building a robust smart grid is suitable for sustainable development. Streamlining and simplification of existing permission procedures and standardisation of the grid codes for the connection of distributed generation is required to encourage greater distributed resources integration. The standardization in the connection requirements of distributed generation, particularly of the protection equipment and settings criteria, will be very positive for the development of the distributed generation, especially in highly interconnected networks to avoid nuisance tripping and obtain more generation availability and so network stability.

With advance of smart grid and increasing number of equipment being supply by smart devices such as electrical vehicles, power harmonics are drawing more attentions from researchers. This thesis proposed some wavelet based algorithm dealing with power quality problems. Signal processing is the main issue for power quality analysis. A new hybrid Neural-Wavelet model for short-term load prediction model is also concluded.

The WT-based harmonic analysis algorithm and dynamic waveform reconstruction algorithm are very effective and accurate in solving harmonic problems presented in this thesis. The only drawback of the algorithms is the computation time required. The proposed algorithms were implemented in Matlab standard software in Windows platform.

9.2 Trends and Further work

Due to the agreement of 2009 United Nations Climate Change Conference, building a smarter grid is a positive trend to the future super power grid. CO₂ emissions should be firstly taken into consideration during economic development. So the clean energy will be involved in super smart grid. In the future, the super power grid should be much smarter than smart grid. Distributed generation, smarter transmission grid, smarter distribution grid and smarter meters will be involved in smarter meter. Renewable energy will have a significant impact on the future grid development and evolution. Hence, power quality on distributed resources is a very critical issue in the future power grid.

As a significant components of smart grid, future development of smart metering plays as a linchpin on communication between power grid and customers. The existed concept of smart grid has provided a real-time price for customers to realize their bill cost and reduce their energy consumption.

But when given real-time price data, the best optimal methods for cheaper cost is grasped by experts other than command customers. So there will be a trend that integrates the smart meter and the AI technology helping customers on designing an optimal energy consumption plan. Customers from different consuming styles would have a requirement on different optimal algorithm so the integration should be area faced. Forms of product could be flexible. E.g. the smart meter could be integrated by a software platform so that the customers download the specific optimal software of their own.

Also, before applied to the power grid, influence from this technology to the grid management should also be researched and simulated.

Renewable energy is deeply coupled in smart grid design. In the idea of smart grid, renewable energy is defined more general. Such as solar, wind energy and fuel cell, sources on these energy are easier collected generally and less strict. But for some special places that these two limits vanish, smart grid should also consider the energy from these strict sources.

Subterranean heat is one of the mentioned sources above. Not many districts have enough subterranean heat for energy generation. One example is Iceland, who claims that more than 80% people in Iceland use subterranean heat for heating. For this reason, the smart grid in Iceland should be special for feature of subterranean heat, causing this grid network different from others.

Space energy is also a good area for renewable energy. Several kinds of energy forms outside the earth is been realized by human being. The most familiar one is the sunlight and the sun-heat. Solar on the earth could only receive small part of energy.

The main objective of the thesis is to develop a new power harmonics analysis approach based on wavelet transform for power quality analysis, the algorithm suggested has the important feature that can be further developed for the analysis of oscillatory transients, which are typically caused by line switching, capacitor switching and load switching in future smart grid.

An integrated approach would also be developed based on the WT-based harmonic analysis and waveform reconstruction algorithms suggested in this thesis and DWT-based power disturbance analysis algorithm for comprehensive power quality analysis.

Further research works would be conducted to modify the proposed algorithms for oscillatory transient frequency estimation and waveform reconstruction.

Recently, Smart grid related to power quality is a very hot topic, I attached a list of references from PES annual meeting 2010 for convenient of readers. [108-149]

Appendix MATLAB code

Warning: The following MATLAB code cannot be run in any form or in any way without author's permission!

Input signal:

```
t = 0:1/6400:0.6;
pa = ones(1,3841);
```

```
counter = 0;
```

```
for counter = 1281:2560
```

```
    pa(counter) = 0.7;
```

```
end
```

```
y = 311*cos(2*pi*49.5*t).*pa+ 288*cos(2*pi*102*t + 10*pi/180)+
280*cos(2*pi*148.5*t - 15*pi/180).*pa + 225*cos(2*pi*247.5*t - 12*pi/180).*pa +
180*cos(2*pi*346.5*t - 20*pi/180)+ 155*cos(2*pi*445.5*t - 14*pi/180)+
130*cos(2*pi*544.5*t + 30*pi/180)+ 102*cos(2*pi*643.5*t + 36*pi/180)+
80*cos(2*pi*742.5*t + 42*pi/180)+ 76*cos(2*pi*811*t + 11*pi/180)+
53*cos(2*pi*940.5*t + 5*pi/180)+ 20*cos(2*pi*1336.5*t + 8*pi/180)+
15*cos(2*pi*1534.5*t + 20*pi/180)+ 13*cos(2*pi*1633.5*t - 30*pi/180)+
9*cos(2*pi*1831.5*t - 8*pi/180) + 7*cos(2*pi*1930.5*t + 9*pi/180) +
3*cos(2*pi*2128.5*t + 3*pi/180);
```

Low harmonics:

```
function [f,ridges] = new_cwt_low_harmonics(sig,fs,T)
```

```
% The function estimates the frequency and the amplitude of input signal
harmonics whose frequency is larger than 50Hz.
```

```
% Input of this function contains 3 elements. Sig is a vector containing
% signal data ; fs is a number standing for the sampling frequency ; T is
% a number standing for the signal time length.
```

```
%
```

```
% Output of this function contains two elements. f is a frequency vector
% used as the frequency axis. ridges is the amplitude of each harmonics
```



```

% component corresponding to each frequency.

% Start Time
a = fix(clock);
sprintf('Start Time(hh:mm:ss): %02d:%02d:%02d', a(4), a(5), a(6))

hfsep=20;
b=100;
% duration
t=double((-T/2:1/fs:T/2));
% length time
% search frequency
f=40:0.5:2000;
flen=length(f);
c=0.01/hfsep;
a=c-0.005*f.^(-1);
% pre-allocate cw for faster execution
cw = zeros(1,flen);
% Loop
for j=1:flen;
    % construct complex morlet wavelet
    amp = (pi)^(-0.5)/b/fs/a(j)*exp(-(t/b/a(j)).^2);
    scmor = amp.*exp(i*2*pi*f(j)*t);
    % convolution at mid-point only
    cw(j) = sig*scmor'*2;
end;

% plot
ridges=abs(cw);
plot(f,ridges);

% End Time
a = fix(clock);
sprintf('End Time(hh:mm:ss): %02d:%02d:%02d', a(4), a(5), a(6))
end

```

Sub-harmonics:

```

function ridges = cwt_sub_harmonics()
% This function estimates the harmonics of cos (2*pi*50*t).
fs=105;
T=1.6;
% create signal
tt = 0 : 1/fs : T;

```



```
sig = cos(2*pi*50*tt);
sfsep=3.6;
b=100;
% duration
t=double((-T/2:1/fs:T/2));
% length time
% N=int32(length(t));
% m=int32(length(t)/2);
% search frequency
f=10:0.1:52;
flen=length(f);
a=0.01*(1/sfsep-f.^(-1)/2);
% pre-allocate cw for faster execution
cw = zeros(1,flen);
% loop
for j=1:1:flen;
    % construct complex morlet wavelet
    amp = (pi)^(-0.5)/b/fs/a(j)*exp(-(t/b/a(j)).^2);
    scmor = amp.*exp(i*2*pi*f(j)*t);
    % convolution at mid-point only
    cw(j) = sig*scmor'*2;

end;
% plot
ridges=abs(cw);
plot(f,ridges);

end
```

REFERENCES

- [1] M. Amin and B. Wollenberg, "Towards a smart grid" IEEE Power and Energy Magazine, Vol.3, No 5, Sept/Oct. 2005, pp34-38
- [2] S. Ray, G. K. Venayagamoorthy, "Real-time implementation of a measurement based adaptive wide area control system considering communication delays", IET Proceedings on Generation, Transmission and Distribution, Vol. 2, 1, Jan. 2008, pp62-70.
- [3] W. Qiao, G. K. Venayagamoorthy, R. G. Harley, "Missing-sensor-fault-tolerant control for SSSC FACTS device with real-time implementation", IEEE Transactions on Power Delivery, Vol.24, No 2, April 2009, pp740-750.
- [4] Ringo Lee and L.L. Lai, "Smart metering in micro-grid applications," IEEE Power and Energy Society General Meeting, Canada, July 2009, pp1-5.
- [5] G.K.Venayagamoorthy, "Potential and promises of computational intelligence for the smart grid," IEEE Power and Energy Society General Meeting, Canada, July 2009, pp1-6.
- [6] Lei Wang, Preetika Kulshrestha and Mo-Yuen Chow, "Intelligent energy management system for PHEVs at municipal parking deck in a smart grid environment," IEEE Power and Energy Society General Meeting, Canada, July 2009, pp1-6.
- [7] C.Sasse, "Electricity Networks of the Future", IEEE Power and Energy Society General Meeting, Canada, Oct 2006, pp7.

[8] European Commission, “European Electricity Projects 2002 – 2006”, 2007, [Online]. Available: <http://ec.europa.eu/research/rtdinfo>. Visited on Apr 1 2009.

[9] Fred Sissine (Coordinator), Energy Independence and Security Act of 2007: A Summary of Major Provisions, CRS Report for Congress, Order Code RL34294, 21 Dec 2007.

[10] “Smart Grid Thinking”, Engineering & Technology Magazine, 25 May 2009, pp 46-49.

[11] Yu.Yi.Xin, “Technical Composition of Smart Grid and its Implementation Sequence”, First Smart Grid Research Panel, pp 243-247.

[12] IEEE SMART GRID NIST Smart Grid Framework

[Online] Available: <http://smartgrid.ieee.org/nist-smartgrid-framework>. Visited on Apr 6 2010.

[13] IEEE SMART GRID Bulk Generation [Online]. Available:

<http://smartgrid.ieee.org/nist-smartgrid-framework/bulk-generation>. Visited on Apr 6 2010.

[14] IEEE SMART GRID Transmission [Online]. Available:

<http://smartgrid.ieee.org/nist-smartgrid-framework/transmission>. Visited on Apr 6 2010.

[15] IEEE SMART GRID Distribution [Online]. Available:

<http://smartgrid.ieee.org/nist-smartgrid-framework/distribution>. Visited on Apr 6 2010.

[16] IEEE SMART GRID Customer [Online]. Available:

<http://smartgrid.ieee.org/nist-smartgrid-framework/customer>. Visited on Apr 6 2010.

[17] IEEE SMART GRID Operations [Online]. Available:

<http://smartgrid.ieee.org/nist-smartgrid-framework/operations>. Visited on Apr 6 2010.

[18] IEEE SMART GRID Markets [Online]. Available:

<http://smartgrid.ieee.org/nist-smartgrid-framework/markets>. Visited on Apr 7 2010.

[19] IEEE SMART GRID Service Provider [Online]. Available:

<http://smartgrid.ieee.org/nist-smartgrid-framework/service-provider>. Visited on Apr 7 2010.

[20] Y.N, Ma, Long.Zhou , N. Tse , Osman,A ,L.L.Lai , “An initial study on computational intelligence for smart grid ”, Proceedings of 2009 International Conference on Machine Learning and Cybernetics IEEE (ICMLC 2009), 2009.07, pp3425-3429.

[21] Momoh, J.A, “Smart grid design for efficient and flexible power networks operation and control”, Power Systems Conference and Exposition, 2009. PSCE '09. IEEE/PES.

[22] Rob van Gerwen, Saskia Jaarsma and Rob Wilhite, “Smart Metering”, Distributed Generation, Huly 2006.

[23] Energy retail association, “Smart Meters”, [Online].Available:

<http://www.energy-retail.org.uk/smartmeters.html>. Visited on Nov 30 2009.

[24] “China to announce massive Smart Meter & Grid Project”, [Online].Available:

<http://www.smartmeters.com/the-news/547-china-to-announce-massive-smart-meter-a-grid-project.html>. Visited on Nov 30 2009.

[25] “BSI launches work on new standards on smart metering”, [Online] Available:[http://shop.bsigroup.com/en/Browse-by-Sector/Energy--Utilities/Smart-metering\](http://shop.bsigroup.com/en/Browse-by-Sector/Energy--Utilities/Smart-metering/). Visited on Nov 12 2009.

[26] “Smart Meters Co-ordination Group Ad hoc Group on Additional functionalities”, [Online]. Available:http://www.theapplicationhome.com/NewFiles/SG2_AF_220609.pdf. Visited on Dec 30 2009.

[27] “MCE Decision paper”, A National Minimum Functionality for Smart Meters” [Online]. Available:http://www.ret.gov.au/Documents/mce/_documents/MCE_Decision_Paper_A_National_Minimum_Functionality_for_Smart_Meters20071213153847.pdf. Visited on Nov 1 2009.

[28] “Smart meters 197 standards are forming”, [Online]. Available:<http://www.chinapower.com.cn/article/1163/art1163497.asp>. Visited on Dec 29 2009.

[29] “ZigBee Smart Energy”, [Online]. Available:<http://www.zigbee.org/Markets/ZigBeeSmartEnergy/ZigBeeSmartEnergyOverview/tabid/431/Default.aspx>. Visited on Nov 4 2009.

[30] “ZigBee to be wireless standard for smart meters in Europe”, [Online]. Available:<http://www.electronicweekly.com/Articles/2009/05/29/46180/zigbee-to-be-wireless-standard-for-smart-meters-in-europe.htm>. Visited on Nov 4 2009.

[31] “Echelon smart meter technology becomes ISO/IEC standard”, [Online]. Available:<http://www.smartmeters.com/the-news/50--echelon-smart-meter-technology-becomes-isoiec-standard-.html>. Visited on Nov 4 2009.

[32] Lee.P.K., Lai. L.L,“A practical approach of smart metering in remote monitoring of renewable energy applications“, Power & Energy Society General Meeting, 2009. PES, 26-30 July 2009 pp1 – 4.

[33] “What smart meters will do for you”,

[Online].Available: <http://news.bbc.co.uk/1/hi/business/8023507.stm>. Visited on Dec 6 2009.

[34] Gerwen, R.J.F, Jaarsma, S. and Koenis, F., Domme meters worden slim? Kosten-batenanalyse slimme meetinfrastructuur, Arnhem, 30 August 2005.

[35] “Italy – 27 Million Smart Meters”,

[Online].Available:<http://neuralenergy.blogspot.com/2009/07/italy.html>. Visited on Dec 6 2009.

[36] “Italy’s Smart Meter Revolution: Showing the World how it’s done”,
[Online].Available:<http://www.energyboom.com/emerging/italys-smart-meter-revolution-showing-world-how-its-done>. Visited on Dec 8 2009.

[37] “Smart Meter”,

[Online].Available: http://en.wikipedia.org/wiki/Smart_meter. Visited on Dec 9 2009.

[38] “Pacific Gas and Electric Company's Smart Meter Proposal Approved by California Public Utilities Commission”,

[Online].Available:http://www.pge.com/about/news/mediarelations/newsreleases/q3_2006/060720a.shtml. Visited on Dec 11 2009.

[39] “Advanced Metering Infrastructure for Victoria”,

[Online].Available:<http://www.dpi.vic.gov.au/dpi/dpinenergy.nsf/LinkView/4EC2E4EA42B821FCCA2572B10079A930A8BAF6E4E66C900FCA2572B20004C403>.

Visited on Dec 13 2009.

[40] “ERDF and Atos Origin Partner on Smart Meters”,

[Online].Available:<http://smartelectricnews.blogspot.com/2008/07/erdf-and-atos-origin-partner-on-smart.html>. Visited on Dec13 2009.

[41] Y. Meyer, “Wavelets: Algorithms and Applications”, Society for Industrial and Applied Mathematics, Philadelphia, 1993, pp. 13-31, 101-105.

[42] Barbara B Hubbard, "The world according to wavelets," A K Peters Ltd., Wellesley, MA, 1996.

[43] Y Meyer, "Ondeletts, ondeletts et operateurs," Paris: Hermann, 1990.

[44] Stephane Mallet, A wavelet tour of signal processing, Academic Press, 1998.

[45] Fu.Z.Lin, “Basics of Multimedia Technology”, Second edition, Sep.2002 , QingHua University press, pp140-165.

[46] “Wavelet”

[Online].Available: <http://en.wikipedia.org/wiki/Wavelet> .Visited on Dec13 2009.

[47] Teolis, A., Computational signal processing with wavelets, Birkhauser, 1998.

[48] Gilbert Strang and Truong Nguyen, Wavelets and Filter Banks, Wellesley-Cambridge Press, Wellesley, MA, January, 1996.

[49] “Wavelet Mathwork”

[Online]. Available: http://www.mathwork.com/access/helpdesk/help/toolbox/wavelet/wavelet_tocframe.shtml. Visited on Dec 13 2006.

[50] Robi Polikar, "The story of wavelets," In *Physics and Modern Topics in Mechanical and Electrical Engineering* (ed. N Mastorakis), pp. 192-197, World Scientific and Eng. Press,

[Online]. Available: <http://engineering.rowan.edu/%7epolikar/WAVELETS/WTutorial.ht>. Visited on Dec 1 2007.

[51] Misiti, M., Misiti, Y., Oppenheim, G.: "Wavelet Toolbox for use with Matlab," (The Mathworks Inc., March 1996), pp.6-43.

[52] Weon-Ki Yoon and Michael J. Devaney, "Power measurement using the wavelet transform," *IEEE Trans. Instrument & Measurement*, Vol. 47 No. 5, pp.1205-1210, Oct. 1998.

[53] Johan L. J. Driesen and Ronnie J. M. Belmans, "Wavelet-based power quantification approaches," *IEEE Trans. Instrument & Measurement*, Vol. 52 No.4, pp. 1232-1238, Aug. 2003.

[54] V. L. Pham and K. P. Wong, "Wavelet-transform-based algorithm for harmonic analysis of power system waveforms," *IEE Proc. - Gener. Transm. Distrib.*, Vol. 146, No. 3, May 1999.

[55] Lee C. H., J. S. Lee, J. O. Kim and S. W. Nam, "Feature vector extraction for the automatic classification of power quality disturbances," *The 1997 IEEE International Symposium on Circuits and Systems*, pp.2681-2684, Hong Kong, PRC, 1997.

[56] Galli A. W., "Analysis of electrical transients in power systems via a novel wavelet recursive method," Ph.D Dissertation, Purdue University, Purdue, IN, USA.

[57] Meliopoulos A. P. S. and C. H. Lee, "Power disturbance analysis via wavelet domain equivalents," The 1998 International Conference on Harmonics and Quality of Power, pp.388-394, Athens, Greece.

[58] Chaari O. M. Meunier and F. Brouaye, "Wavelets: a new tool for the resonant grounded power distribution systems relaying," IEEE Trans. Power Delivery, 11(3), pp.1301-1308, 1996.

[59] Islam Md. S., A. H. Samra and J. Andrian, "Wavelet transform analysis arrestor voltage in surge motor protection," The 1996 IEEE Southern Bringing together Education, Science and Technology, pp.305-308, Tampa, FL., USA.

[60] Gomes-Morgante M. and D. W. Nicollete, "A wavelet based differential transformer protection," The 1999 IEEE/PES Winter Meeting, New York, NY, USA, 1999.

[61] Surya S., W. Mack Grady, E. J. Powers, J. Lamoree, S. C. Siddharth, "Characterization of distribution power quality events with Fourier and wavelet transforms," IEEE Trans. Power Delivery, Vol. 15, No. 1, pp.247-254, Jan. 2000.

[62] Santoso S., E. J. Powers, and W. M. Grady and P. Hoffman, "Power quality assessment via wavelet transform analysis," IEEE Trans. Power Delivery, 11(2), pp.924-930, 1996.

[63] Angrisani L., P. Daponte, M. D' Apuzzo, and A. Testa, "A method based on wavelet networks for the detection and classification of transients," IEEE Instrumentation Measurement Technology Conference, pp. 903-908, St. Paul, MN, USA.

- [64] L. Angrisani, P. Daponte, M.D' Apuzzo and A. Testa, "A measurement method based on the wavelet transform for power quality analysis," *IEEE Trans. Power Delivery*, Vol. 13, No. 4, pp.990-998, Oct. 1998.
- [65] L L Lai, W L Chan, C T Tse and A T P So, "Real-time frequency and harmonic evaluation using artificial neural networks," *IEEE Trans. on Power Delivery*, Vol. 14, No. 1, January 1999, pp.52-59.
- [66] W L Chan, A T P So and L L Lai, "Harmonics load signature recognition by wavelets transforms", *Proceedings of the International Conference on Electric Utility Deregulation, Restructuring and Power Technologies DRPT2000*, IEEE Catalog Number 00EX382, April 2000, pp. 666-671.
- [67] Shyh-Jier Huang, Cheng-Tao Hsieh, "Application of continuous wavelet transform for study of voltage flicker-generated signals," *IEEE Trans. Aerospace and Electronic Systems*, Vol. 36, No. 3, pp. 925-932, July 2000.
- [68] Zhang C., Y. Huang, X. Ma, W. Lu and G. Wang, "A new approach to detect transformer inrush current by applying wavelet transform," *The 1998 International Conference on Power System Technology*, pp.1040-1044, Beijing, P.R.C.
- [69] Pandey S. K. and L. Satish, "Multiresolution signal decomposition: a new tool for fault detection in power transformers during impulse tests," *IEEE Trans. Power Delivery*, 13(4), pp.1194-1200, 1998.
- [70] Terwiesch P., S. Menth and S. Schmidt, "Analysis of transients in electrical railway networks using wavelets," *IEEE Trans. Industrial Electronics*, 45(6) pp. 955-959, 1998.
- [71] Chung J. and E. J. Powers, "Variable rate power disturbance signal compression

using embedded zerotree wavelet transform," The 1999 IEEE/PES Winter Meeting, New York, NY, USA, 1999.

[72] Paul S Addison, *The Illustrated Wavelet Transform Handbook*, Institute of Physics Publishing Ltd., Bristol and Philadelphia, 2002.

[73] Carbone R., Testa A., Menniti D., Morrison R. E. and, Delaney E. "Harmonic and inter-harmonic distortion in current source type inverter drives," *IEEE Trans. Power Delivery*, Vol. 10, No. 3, pp.1576-1583, July 1995.

[74] Steven W. Smith, *Digital signal processing: a practical guide for engineers and scientists*, Newnes, 2002.

[75] Robert W. Ramirez, *The FFT: fundamentals and concepts*, Englewood Cliffs, N.J., Prentice-Hall, 1985.

[76] Adly A. Girgis, "A Quantitative Study of Pitfalls in the FFT," *IEEE Trans. Aerospace & Electronic Systems*, Vol. AES-16, No. 4, pp.434-439, July 1980.

[77] V. L. Pham and K. P. Wong, "Wavelet-transform-based algorithm for harmonic analysis of power system waveforms," *IEE Proc. - Gener. Transm. Distrib.*, Vol. 146, No. 3, May 1999.

[78] Norman C F Tse, "Practical application of wavelet to power quality analysis", *Proceedings of the 2006 IEEE Power Engineering Society General Meeting*, IEEE Catalogue Number 06CH37818C, June 2006, CD ROM.

[79] Shyh-Jier Huang, Cheng-Tao Hsieh, "Application of continuous wavelet transform for study of voltage flicker-generated signals," *IEEE Trans. Aerospace and Electronic Systems*, Vol. 36, No. 3, pp. 925-932, July 2000.

- [80] Norman C. F. Tse and L. L. Lai, "Wavelet-based algorithm for signal analysis," *EURASIP Journal on Advances in Signal Processing*, Vol. 2007, Article ID 38916.
- [81] Robertson, D. C. and Camps O. I., "Wavelets and electromagnetic power system transients", *IEEE Trans.*, 1996, PWRD-11, (2), pp.1050-1058.
- [82] V. L. Pham and K. P. Wong, "Antidistortion method for wavelet transform filter banks and nonstationary power system waveform harmonic analysis," *IEE Proc. – Gener. Transm. Distrib.*, Vol. 148, No. 2, March 2001.
- [83] Karen L. Butler-Purry and Mustafa Bagriyanik, "Characterization of transients in transformers using discrete wavelet transforms," *IEEE Trans. Power System*, Vol. 18, No. 2, pp. 648-656, May 2003.
- [84] René A. Carmona, Wen L. Hwang and Brun Torrèsane, "Characterization of signals by the ridges of their wavelet transforms," *IEEE Trans. Signal Processing*, Vol. 45, No. 10, pp.2586-2590, Oct. 1997.
- [85] IEEE Recommended Practices and Requirements for Harmonic Control in Electrical Power Systems, IEEE Std.519-1992.
- [86] IEC 61000 series: "Electromagnetic Compatibility (EMC)."
- [87] ER G5/4-1: "Planning levels for harmonic voltage distortion and the connection of non-linear equipment to transmission and distribution systems in the United Kingdom," UK Energy Networks Association.
- [88] Draft BS EN 61000-3-14 ed.1:2008."Electromagnetic compatibility (EMC) - Part 3-14: Assessment of emission limits for the connection of disturbing installations to

LV power systems."IEEE recommended practice for monitoring electric power quality, IEEE Standards Board, June 1995.

[89] N. Tse, L. Zhou and L L Lai, "Wavelet-Based Algorithm for Nonstationary Power System Waveform Analysis," International Conference on Wavelet Analysis and Pattern Recognition (ICWAPR) 2008, August 30, 31, Hong Kong, PRC.

[90] P. J. Santos, A. G. Martins, A. J. Pries, J. F. Martins, R. V. Mendes, "Short-Term Load Forecast Using Trend Information and Process Reconstruction," International Journal of Energy Research, pp.811-822, 2006.

[91] D.K. Ranaweera, G.G. Karady, R.G. Farmer, "Effect of probabilistic inputs on neural network-based electric load forecasting," IEEE Trans. Neural Works, vol.7, No.6, pp.1528–1532. 1996.

[92] J. N. Bastian, J. Zhu, V. Banunarayana, R. Mukerji, Forecasting energy prices in a competitive market, IEEE Computer Appl. Power, vol.13, No.3, pp. 40–45. 1999.

[93] Amir B. Geva, "ScaleNet - Multiscale neural-network architecture for time series prediction," IEEE Trans. Neural Networks, Vol. 9, No. 5, pp. 1471-1482, 1998.

[94] A. Oonsivilai and El-Hawary, "Wavelet Neural Network Based Short Term Load Forecasting of Electric Power System Commercial Load," IEEE Proceedings, pp.1223-1228, 1999.

[95] O. Renaud, J. -L. Starck and F. Murtagh, "Wavelet-based Forecasting of Short and Long Memory Time Series," 2002.

[96] Cheng-Jian Lin, "Wavelet Neural Networks with a Hybrid Learning Approach," Journal of Information Science and Engineering 22, pp. 1367-1387, 2006.

[97] Chang-il Kim, In-keun Yu, Y.H. Song, “Kohonen neural network and wavelet transform based approach to short-term load forecasting,” *Electric Power Systems Research* 63, pp.169-176, 2002.

[98] N. Satio, G. Beylkin, “Multiresolution representations using the auto-correlation functions of compactly supported wavelets”, *IEEE Trans. Signal Processing*, 41, No. 12 (1993) pp. 3584–3590.

[99] Daubechies, I., *ten Lectures on Wavelets*, CBMS-NSF, SIAM, 1992.

[100] K. P. Soman, and K. I. Ramachandran, “Insight Into Wavelets From Theory to Practice,” Prentice-Hall of India, 2004.

[101] D. Benaouda, F. Muratagh, J.L. Starck, and O. Renaud. “Wavelet-Based Nonlinear Multiscale Decomposition Model for Electricity Load Forecasting,” *Neurocomputing* 70 Elsevier, pp 139-154, 2006.

[102] J. Park and I.W. Sandberg: “Universal approximation using radial basis function networks”, *Neural Computation*, Vol.3(2), 1991, pp.246-257.

[103] S. Chen, C. F. N. Cowan, and P. M. Grant, “Orthogonal least squares learning algorithm for radial basis function networks,” *IEEE Trans. Neural Networks*, vol. 2, pp. 302–309, 1991.

[104] Australian National Electricity Market Management Company Limited (NEMMCO).

[Online]. Available: <http://www.nemmco.com.au/>. Visited on Apr12 2008

[105] “IEEE 802.15.4-2006”, Wikipedia, the free encyclopedia,

[Online].Available: http://en.wikipedia.org/wiki/IEEE_802.15.4-2006. Visited on Sep19 2010

[106] “Power quality”, Wikipedia, the free encyclopaedia,

[Online].Available: http://en.wikipedia.org/wiki/Power_quality. Visited on Sep20 2010

[107] “Power quality terms and definitions”, PQ Network,

[Online].Available: <http://www.mtm.at/pqnet/PQDEF.htm>. Visited on Sep20 2010

[108] Remy Rigo-Mariani, Ramesh K. Rayudu, Mike S. Witherden and Edmund Lai, “Power Quality Indices of Compact Fluorescent Lamps for Residential Use – A New Zealand Study”, IEEE Power and Energy Society General Meeting 2010, paper ID:000024 , July 2010

[109] Rodrigo Hartstein Salim, Mario Oleskovicz, Rodrigo Andrade Ramos, “Assessment of Voltage Fluctuations Induced by Electromechanical Oscillations in Distributed Generation Systems”, IEEE Power and Energy Society General Meeting 2010, paper ID:000028 , July 2010

[110] Gao Lei, Li wenfeng, Zhang wenchao, Zhu fang, Chu.Q.Liu, Liu Zenghuang, Zhao hongguang, “Verification of System Dynamic Performance of the 1000kV Synchronized Grid”, IEEE Power and Energy Society General Meeting 2010, paper ID:000034 , July 2010

[111] Cuong D. Le, Irene Y.H. Gu, and Math H.J. Bollen, “Joint Causal and Anti-Causal Segmentation and Location of Transitions in Power Disturbances”, IEEE Power and Energy Society General Meeting 2010, paper ID:000040 , July 2010

[112] E. C. Guardia, A. R. Queiroz, J. W. Marangon Lima, “Estimation of Electricity Elasticity for Demand Rates and Load Curve in Brazil”, IEEE Power and Energy

Society General Meeting 2010, paper ID:000044 , July 2010

[113] A.Bracale, G.Carpinelli, P.Caramia, P.Verde, R.Chiumeo, F.Tarsia, “System Voltage Quality Regulation for Continuous Disturbances”, IEEE Power and Energy Society General Meeting 2010, paper ID:000059 , July 2010

[114] Dr.Ing.Tevfik Sezi, Siemens A.G, Nuremerberg, “Fast and Accurate Measurement of Power System Frequency”, IEEE Power and Energy Society General Meeting 2010, paper ID:000107 , July 2010

[115] S. Corsi, F. De Villiers and R. Vajeth, “Secondary Voltage Regulation Applied to the South Africa Transmission Grid”, IEEE Power and Energy Society General Meeting 2010, paper ID:000154 , July 2010

[116] Bhuvanewari Ramachandran, Sanjeev K.Srivastava, David A.Cartes, and Chris.S.Edrington, “Distributed Energy Resource Management in a Smart Grid by Risk Based Auction Strategy for Profit Maximization”, IEEE Power and Energy Society General Meeting 2010, paper ID:000192 , July 2010

[117] Amir Motamedi, Hamidreza Zareipour, William D. Rosehart , “Electricity Market Price Forecasting in a Price-responsive Smart Grid Environment”, IEEE Power and Energy Society General Meeting 2010, paper ID:000193 , July 2010

[118] M. F. Faisal, A. Mohamed, and H. Shareef, “A Novel Method for Upstream Asymmetrical Voltage Sag-Source Detection”, IEEE Power and Energy Society General Meeting 2010, paper ID:000240 , July 2010

[119] Andreas Tolk, “Architecture Constraints for Interoperability and Composability in a Smart Grid”, IEEE Power and Energy Society General Meeting 2010, paper ID:000247 , July 2010

[120] Ali Nourai, Ram Sastry and Thomas Walker, "A Vision & Strategy for Deployment of Energy Storage in Electric Utilities", IEEE Power and Energy Society General Meeting 2010, paper ID:000250 , July 2010

[121] A Nagarajan, W Shireen, "Grid Connected Residential Photovoltaic Energy Systems with Plug-In Hybrid Electric Vehicles(PHEV) as Energy Storage", IEEE Power and Energy Society General Meeting 2010, paper ID:000284 , July 2010

[122] Anupama Kowli, Matias Negrete-Pincetic and George Gross, "A Successful Implementation with the Smart Grid: Demand Response Resources", IEEE Power and Energy Society General Meeting 2010, paper ID:000312 , July 2010

[123] Hongrui Liu, Zelda B. Zabinsky, and Wolf Kohn, "Rule-based Control System Design for Smart Grids", IEEE Power and Energy Society General Meeting 2010, paper ID:000315 , July 2010

[124] MarkG.Lauby, "Reliability Considerations for Application of Smart Grid Technologies", IEEE Power and Energy Society General Meeting 2010, paper ID:000318 , July 2010

[125] Gary.W.Chang and Cheng-I Chen, "Performance Evaluation of Voltage Sag Detection Methods", IEEE Power and Energy Society General Meeting 2010, paper ID:000335 , July 2010

[126] Sioe.T.Mak, "Sensor Data Output Requirements for Smart Grid Applications", IEEE Power and Energy Society General Meeting 2010, paper ID:000371 , July 2010

[127] James A.Kavicky, "Impacts of Smart Grid Data on Parallel Path and Contingency Analysis Efforts", IEEE Power and Energy Society General Meeting 2010, paper ID:000391 , July 2010

[128] P.J.M.Heskes, J.M.A.Myrzik and W.L.Kling, "Harmonic Distortion and Oscillatory Voltages and the Role of Negative Impedance", IEEE Power and Energy Society General Meeting 2010, paper ID:000413, July 2010

[129] P. Wang, J. Y. Huang, Y. Ding, P. Loh and L. Goel, "Demand Side Load Management of Smart Grids Using Intelligent Trading/Metering/ Billing System", IEEE Power and Energy Society General Meeting 2010, paper ID:000500, July 2010

[130] Thomas J. Overbye, Jamie D. Weber, "The Smart Grid and PMUs: Operational Challenges and Opportunities", IEEE Power and Energy Society General Meeting 2010, paper ID:000580, July 2010

[131] S.E.Widergren and H.Kirkham, "Smart Grid - Transforming Power System Operations", IEEE Power and Energy Society General Meeting 2010, paper ID:000606, July 2010

[132] D.Haughton and G.T.Heydt, "Smart Distribution System Design: Automatic Reconfiguration for Improved Reliability", IEEE Power and Energy Society General Meeting 2010, paper ID:000662, July 2010

[133] Danny Pudjianto, Chin Kim Gan, Vladimir Stanojevic, Marko Aunedi, Predrag Djapic, Goran Strbac, "Value of Integrating Distributed Energy Resources in the UK Electricity System", IEEE Power and Energy Society General Meeting 2010, paper ID:001510, July 2010

[134] Chanan Singh and Alex Sprintson, "Reliability Assurance of Cyber-Physical Power Systems", IEEE Power and Energy Society General Meeting 2010, paper ID:001511, July 2010

[135] Siddharth Suryanarayanan , Paulo F. Ribeiro, and M. Godoy Simões, "Grid

Modernization Efforts in the USA and Brazil – Some Common Lessons Based on the Smart Grid Initiative”, IEEE Power and Energy Society General Meeting 2010, paper ID:001512, July 2010

[136] Siddharth Sridhar and G. Manimaran, “Data Integrity Attacks and their Impacts on SCADA Control System”, IEEE Power and Energy Society General Meeting 2010, paper ID:001522, July 2010

[137] R.Podmore, “Smart Grid Restoration Concepts”, IEEE Power and Energy Society General Meeting 2010, paper ID:001540, July 2010

[138] Benjamin Kroposki, and Gregory Martin, “Hybrid Renewable Energy and Microgrid Research Work at NREL”, IEEE Power and Energy Society General Meeting 2010, paper ID:001545, July 2010

[139] James McCalley, Eduardo Ibáñez, Yang Gu, Konstantina Gkritza, Dionysios Aliprantis, Lizhi Wang, Arun Somani, Robert Brown, “National Long-Term Investment Planning for Energy and Transportation Systems”, IEEE Power and Energy Society General Meeting 2010, paper ID:001550, July 2010

[140] Rodrigo Moreno, Danny Pudjianto, Goran Strbac, “Future Transmission Network Operation and Design Standards to Support a Low Carbon Electricity System”, IEEE Power and Energy Society General Meeting 2010, paper ID:001552, July 2010

[141] M. Saeedifard, M. Graovac, R.F. Dias, and R. Iravani, “DC Power Systems: Challenges and Opportunities”, IEEE Power and Energy Society General Meeting 2010, paper ID:001568, July 2010

[142] Z. A. Vale, H. Morais, H. Khodr, Bruno Canizes, and João Soares, “Technical

and economic resources management in Smart Grids using Heuristic Optimization methods”, IEEE Power and Energy Society General Meeting 2010, paper ID:001618, July 2010

[143] Anjan.Bose, “Models and Techniques for Reliability Analysis of the Smart Grid”, IEEE Power and Energy Society General Meeting 2010, paper ID:001646, July 2010

[144] M.R.Haghifam, A.Hadian, “Simultaneous Placement of Conventional and Renewable DGs in Electric Distribution System”, IEEE Power and Energy Society General Meeting 2010, paper ID:001662, July 2010

[145] Jason Taylor, Arindam Maitra, Mark Alexander, Daniel Brooks, Mark Duvall, “Evaluations of Plug-in Electric Vehicle Distribution System Impacts”, IEEE Power and Energy Society General Meeting 2010, paper ID:001665, July 2010

[146] Alexander J. Flueck, and Cuong P. Nguyen, “Integrating Renewable and Distributed Resources - IIT Perfect Power Smart Grid Prototype”, IEEE Power and Energy Society General Meeting 2010, paper ID:001679, July 2010

[147] Jiaxin Ning, and Wenzhong Gao, “Multi-feature Extraction for Power System Disturbances by Wavelet Transform and Fractal Analysis”, IEEE Power and Energy Society General Meeting 2010, paper ID:001685, July 2010

[148] Angelo Baggini, and Franco Bua, “Overview on PQ development in Europe”, IEEE Power and Energy Society General Meeting 2010, paper ID:001691, July 2010

[149] S.Massoud Amin, “Electricity Infrastructure Security: Toward Reliable, Resilient and Secure Cyber-Physical Power and Energy Systems”, IEEE Power and Energy Society General Meeting 2010, paper ID:001719, July 2010