



# City Research Online

## City, University of London Institutional Repository

---

**Citation:** Milojevic, M. (2015). Location aware data aggregation for efficient message dissemination in Vehicular Ad Hoc Networks. (Unpublished Doctoral thesis, City University London)

This is the accepted version of the paper.

This version of the publication may differ from the final published version.

---

**Permanent repository link:** <https://openaccess.city.ac.uk/id/eprint/14937/>

**Link to published version:**

**Copyright:** City Research Online aims to make research outputs of City, University of London available to a wider audience. Copyright and Moral Rights remain with the author(s) and/or copyright holders. URLs from City Research Online may be freely distributed and linked to.

**Reuse:** Copies of full items can be used for personal research or study, educational, or not-for-profit purposes without prior permission or charge. Provided that the authors, title and full bibliographic details are credited, a hyperlink and/or URL is given for the original metadata page and the content is not changed in any way.





School of Mathematics, Computer Science and Engineering  
City University London

LOCATION AWARE DATA AGGREGATION FOR  
EFFICIENT MESSAGE DISSEMINATION IN  
VEHICULAR AD HOC NETWORKS

Author:

Milos MILOJEVIC

Supervisor:

Dr Veselin RAKOCEVIC

A thesis submitted for the degree of Doctor of Philosophy

May, 2016



*To my family.*

# Abstract

The main contribution of this thesis is the *LA* mechanism - an intelligent, location-aware data aggregation mechanism for real-time observation, estimation and efficient dissemination of messages in VANETs. The proposed mechanism is based on a generic modelling approach which makes it applicable to any type of VANET applications. The data aggregation mechanism proposed in this thesis introduces location awareness technique which provides dynamic segmentation of the roads enabling efficient spatiotemporal database indexing. It further provides the location context to the messages without the use of advanced positioning systems like satellite navigation and digital maps. The mechanism ensures that the network load is significantly reduced by using the passive clustering and adaptive broadcasting to minimise the number of exchanged messages. The incoming messages are fused by Kalman filter providing the optimal estimation particularly useful in urban environment where incoming measurements are very frequent and can cause the vehicle to interpret them as noisy measurements. The scheme allows the comparison of aggregates and single observations which enables their merging and better overall accuracy. Old information in aggregates is removed by real-time database refreshing leaving only newer relevant information for a driver to make real-time decisions in traffic. The *LA* mechanism is evaluated by extensive simulations to show efficiency and accuracy.

# Acknowledgement

I would like to thank my supervisor Dr Veselin Rakocevic for his extensive support during my research. More specifically I welcomed his advice during all stages of the research, from initial problem definition, algorithm design and evaluation, to publishing the research in journals and conferences. Additionally, I am thankful for Dr Rakocevic's support in making the initial research proposal for application to PhD course and scholarship.

# Declaration

I grant powers of discretion to the University Librarian to allow the thesis to be copied in whole or in part without further reference to the author. This permission covers only single copies made for study purposes, subject to normal conditions of acknowledgement.



# Contents

Abstract . . . . .	iv
Acknowledgement . . . . .	v
Declaration . . . . .	vi
List of Symbols . . . . .	x
List of Figures . . . . .	xiii
List of Tables . . . . .	xvii
List of Algorithms . . . . .	.xviii
Abbreviations . . . . .	.xviii
<b>1 Introduction . . . . .</b>	<b>23</b>
1.1 Overview . . . . .	23
1.2 Research contribution . . . . .	26
1.3 Structure of the thesis . . . . .	28
<b>2 Vehicular Ad-Hoc Networks . . . . .</b>	<b>29</b>
2.1 Introduction . . . . .	29
2.2 Standardisation . . . . .	31
2.3 Challenges and initial research motivation . . . . .	42
<b>3 Data Aggregation . . . . .</b>	<b>50</b>

3.1	Introduction . . . . .	50
3.2	Data Aggregation in WSNs . . . . .	51
3.3	Data aggregation in VANETs . . . . .	55
3.3.1	SOTIS . . . . .	68
3.3.2	Traffic View . . . . .	69
3.3.3	Fuzzy Logic Based Structure Free Approach . . . . .	71
3.3.4	Probabilistic Aggregation . . . . .	73
3.3.5	DA2RF . . . . .	75
3.3.6	CASCADE . . . . .	76
3.3.7	Catch-Up . . . . .	78
3.4	Comparative analysis . . . . .	80
<b>4</b>	<b>Location Aware Data Aggregation for VANETs . . . . .</b>	<b>84</b>
4.1	Decision . . . . .	86
4.2	Localisation . . . . .	86
4.3	World Model . . . . .	93
4.4	Fusion . . . . .	96
4.4.1	Case study . . . . .	97
4.4.2	Kalman Filtering . . . . .	102
4.5	Data Dissemination . . . . .	109
<b>5</b>	<b>Performance Evaluation . . . . .</b>	<b>113</b>
5.1	Simulation Tools . . . . .	113
5.2	Simulation Setup . . . . .	117
5.3	Simulation Results . . . . .	120
5.3.1	Efficiency . . . . .	121
5.3.2	Accuracy . . . . .	129
<b>6</b>	<b>Conclusion . . . . .</b>	<b>143</b>

7 Publications and Future work . . . . .	147
Bibliography . . . . .	150

# List of Symbols

Symbol	Description
$\alpha_j$	the width of a single angular band into which $360^\circ$ is divided
$\eta$	the congestion level
$\nu_k$	process noise
$\theta_i$	direction of the street segment $i$ in which the vehicle is currently positioned
$\theta_r$	direction of the neighbouring vehicle
$\Delta\theta$	angular difference of the directions of the two consecutive street segments
$B_k$	control input-model for time $k$
$E_{AVG}$	average error value
$E_{H_j}$	average error for hop 0, 1 or 2
$E(i)$	error value
$F_k$	state transition model of the system
$g$	granularity parameter
$H_k$	measurement (observation) model at time $k$
$h_k$	measurement function at time instant $k$
$i$	counter of traversed street segments
$K$	knowledge depth parameter
$m$	mapping function
$M_k(t)$	a measurement taken by the vehicle at time $t$
$N$	additive white Gaussian noise

$P_{k k-1}$	predicted estimate error covariance for time $k$ based on the information from $k - 1$
$P_{k-1 k-1}$	the updated error covariance for time $k - 1$
$p(x_k x_{k-1})$	conditional distribution
$p(x_{k-1} z_{1:k-1})$	a previous posterior distribution for time $k - 1$
$p(x_k x_{k-1})$	the conditional distribution
$p(x_k z_{1:k-1})$	probability distribution of the state at time $k$ conditioned on all measurements gathered up to time $k - 1$
$p(x_k z_{1:k})$	probability distribution of the state at time $k$ conditioned on all measurements gathered up to time $k$
$p(x_k z_k, z_{1:k-1})$	a probability distribution of the state at time $k$ conditioned on all measurements gathered up to time $k - 1$ and for time $k$
$p(z_k z_{1:k-1})$	normalisation constant
$p(z_k x_k)$	the probability of obtaining the measurements given the state at time instant $k$
$p(z_k x_k, z_{1:k-1})$	measurement model
$Q_k$	process noise covariance for time $k$
$R_k$	measurement noise covariance at time $k$
$S$	total route of the vehicle contained of all street segments
$s_k(\theta_k)$	identification of the street segment whose direction is $\theta_k$
$SC$	spatial communication metric
$s_k$	the innovation (residual) for time step $k$
$t$	time indicator
$T$	time period used for incrementing the congestion levels in the congestion quantification mechanism
$u_k$	control input for time $k$
$V_C$	current speed of the vehicle
$V_t$	threshold speed for activating the congestion detection mechanism

$w_k$	measurement noise
$WM_{PB}$	<i>World Model</i> of the vehicle for <i>PB</i> mechanism
$WM_{LA}$	<i>World Model</i> of the vehicle for <i>LA</i> mechanism
$WM_{DA2RF}$	<i>World Model</i> of the vehicle for <i>DA2RF</i> mechanism
$x_k$	system state at time $k$
$x_{k-1}$	system state at time $k - 1$
$\hat{x}_{k k-1}$	predicted state estimate for time $k$ based on the information from $k - 1$
$\hat{x}_{k-1 k-1}$	the updated state estimate for time $k - 1$
$Z$	integer numbers
$z_k$	measurement at time instant $k$
$z_{1:k}$	measurements obtained up to time $k$

# List of Figures

2.1	Mobile ad-hoc network (MANET). . . . .	30
2.2	Vehicular Ad-hoc network (VANET). . . . .	31
2.3	DSRC protocol stack. . . . .	33
2.4	DSRC spectrum allocation. . . . .	36
2.5	WSM message structure. . . . .	39
2.6	WSA message structure. . . . .	41
3.1	Cluster-based aggregation. . . . .	53
3.2	Chain-based aggregation. . . . .	54
3.3	Tree-based aggregation. . . . .	54
3.4	Urban area with different aggregation structures [43]. . . . .	61
3.5	Data aggregation with short and long periods. . . . .	63
4.1	Generic data aggregation modelling for VANETs. . . . .	85
4.2	Modified generic modelling methodology for data aggregation. . . . .	85
4.3	Route approximation process by consecutive street sections. . . . .	89

4.4	The structure of the message. . . . .	91
4.5	Example scenario of location awareness. . . . .	94
4.6	Congestion quantification process. . . . .	99
4.7	The road network consisting of 80 street sections, and two street sections of the road network one in each direction. . . . .	99
4.8	Detected values of congestion on the vehicle's route. . . . .	100
4.9	The real number of vehicles in the streets on the vehicle's route. . . .	101
4.10	Average value of congestion levels on the route. . . . .	101
4.11	The average number of vehicles in the streets on the vehicle's route. . .	102
4.12	Markov process where the states of the system are not visible. . . . .	104
4.13	Noisy measurements and the Kalman filter estimations. . . . .	106
5.1	Relationship of OMNeT++, SUMO, MiXiM and Veins simulators [82].	115
5.2	SUMO screenshot. . . . .	116
5.3	OMNeT++ screenshot. . . . .	117
5.4	Erlangen city map taken from Veins simulator. . . . .	118
5.5	The number of vehicles in low, medium and high traffic densities. . . .	118
5.6	Overall simulation results in low density scenario (300 vehicles). . . . .	121
5.7	Overall simulation results in medium density scenario (600 vehicles). . .	122
5.8	Overall simulation results in high density scenario (1050 vehicles). . .	122



5.9	Broadcasting frequency distributions of all nodes for the <i>LA</i> (a) and <i>DA2RF</i> (b) mechanisms in low density scenario. . . . .	123
5.10	Broadcasting frequency distributions of all nodes for the <i>LA</i> (a) and <i>DA2RF</i> (b) mechanisms in medium density scenario. . . . .	124
5.11	Broadcasting frequency distributions of all nodes for the <i>LA</i> (a) and <i>DA2RF</i> (b) mechanisms in high density scenario. . . . .	124
5.12	<i>Spatial Communication</i> in low density scenario for the <i>LA</i> , <i>DA2RF</i> and <i>PB</i> mechanisms. . . . .	126
5.13	<i>Spatial Communication</i> in medium density scenario for the <i>LA</i> , <i>DA2RF</i> and <i>PB</i> mechanisms. . . . .	126
5.14	<i>Spatial Communication</i> in high density scenario for the <i>LA</i> , <i>DA2RF</i> and <i>PB</i> mechanisms. . . . .	127
5.15	Average number of detected street segments in low density scenario. . . . .	128
5.16	Average number of detected street segments in medium density scenario. . . . .	128
5.17	Average number of detected street segments in high density scenario. . . . .	128
5.18	Average error values of the <i>LA</i> and <i>DA2RF</i> mechanisms in low density scenario. . . . .	131
5.19	Average error values of the <i>LA</i> and <i>DA2RF</i> mechanisms in medium density scenario. . . . .	131
5.20	Average error values of the <i>LA</i> and <i>DA2RF</i> mechanisms in high density scenario. . . . .	132
5.21	Average error values of the <i>LA</i> mechanisms in low, medium and high density scenario. . . . .	132

5.22	Definition of Hop 0, Hop 1 and Hop 2. . . . .	133
5.23	Per hop error values for the <i>LA</i> (a) and the <i>DA2RF</i> (b) mechanisms in low density scenario. . . . .	134
5.24	Per hop error values for the <i>LA</i> (a) and the <i>DA2RF</i> (b) mechanisms in medium density scenario. . . . .	134
5.25	Per hop error values for the <i>LA</i> (a) and the <i>DA2RF</i> (b) mechanisms in high density scenario. . . . .	135
5.26	Mean values of all the errors recorded for the <i>LA</i> mechanism. . . . .	136
5.27	Mean values of all the errors recorded for the <i>DA2RF</i> mechanism. . . . .	136
5.28	Representation of database slots. . . . .	137
5.29	Average error values for the <i>LA</i> mechanism per database slot in low density scenario. . . . .	137
5.30	Average error values for the <i>LA</i> mechanism per database slot in medium density scenario. . . . .	138
5.31	Average error values for the <i>LA</i> mechanism per database slot in high density scenario. . . . .	138

# List of Tables

2.1	Overview of DSRC specifications. . . . .	34
2.2	802.11p Devices Classification. . . . .	35
2.3	Channel Distribution 802.11p. . . . .	36
3.1	Comparison of data aggregation mechanisms. . . . .	82
4.1	Database structure. . . . .	95
5.1	Simulation parameters. . . . .	119

# List of Algorithms

4.1	The <i>LA</i> technique road segmentation . . . . .	89
4.2	Data dissemination - The <i>LA</i> mechanism . . . . .	112
4.3	Data dissemination - Periodic broadcasting . . . . .	112

# Abbreviations

<b>16QAM</b>	16-Quadrature Amplitude Modulation
<b>64QAM</b>	64-Quadrature Amplitude Modulation
<b>2G</b>	Second Generation of Mobile Networks
<b>3G</b>	Third Generation of Mobile Networks
<b>4G</b>	Fourth Generation of Mobile Networks
<b>5G</b>	Fifth Generation of Mobile Networks
<b>AC</b>	Access Category
<b>AP</b>	Access Point
<b>AOA</b>	Angle of Arrival
<b>BPSK</b>	Binary Phase Shift Keying
<b>BSS</b>	Basic Service Set
<b>BSM</b>	Basic Safety Message
<b>CAM</b>	Cooperative Awareness Message
<b>CCH</b>	Control Channel
<b>CLUDDA</b>	Clustered Diffusion with Dynamic Data Aggregation
<b>CSMA/CA</b>	Carrier Sense Multiple Access with Collision Avoidance
<b>DA2RF</b>	Data Aggregation by Restricting Forwarders

<b>DCF</b>	Distributed Control Function
<b>DSRC</b>	Dedicated Short Range Communication
<b>EDCA</b>	Enhanced Distributed Channel Access
<b>EIRP</b>	Effective Isotropic Radiated Power
<b>ETSI</b>	European Telecommunications Standards Institute
<b>FCC</b>	Federal Communications Commission
<b>FM</b>	Flajolet Martin
<b>GPS</b>	Global Positioning System
<b>HEED</b>	Hybrid Energy-Efficient Distributed Clustering Approach
<b>ID</b>	Identification
<b>IEEE</b>	Institute of Electrical and Electronic Engineers
<b>IP</b>	Internet Protocol
<b>IPv6</b>	Internet Protocol Version 6
<b>ITS</b>	Intelligent Transportation System
<b>IVC</b>	Inter Vehicular Communication
<b>LEACH</b>	Low-Energy Adaptive Clustering Hierarchy
<b>LLC</b>	Logical Link Control
<b>LTE</b>	Long-Term Evolution
<b>MAC</b>	Medium Access Control
<b>MANET</b>	Mobile Ad-Hoc Network
<b>MCTRP</b>	Multi Channel Token Ring Protocol
<b>NS-2</b>	Network Simulator 2

<b>OBU</b>	On Board Unit
<b>OCB</b>	Outside The Context Of BSS
<b>OFDM</b>	Orthogonal Frequency Division Multiplexing
<b>OLSR</b>	Optimized Link-State Routing
<b>PDA</b>	Personal Digital Assistant
<b>PEDAP</b>	Power Efficient Data Gathering and Aggregation Protocol
<b>PEGASIS</b>	Power Efficient Gathering in Sensor Information Systems
<b>PLCP</b>	Physical Layer Convergence Procedure
<b>PSID</b>	Provide Service Identifier
<b>PER</b>	Probability Error Rate
<b>PMD</b>	Physical Medium Dependant
<b>PHY</b>	Physical Layer
<b>POS</b>	Position
<b>QAM</b>	Quadrature Amplitude Modulation
<b>QPSK</b>	Quadrature Phase Shift Keying
<b>QOS</b>	Quality of Service
<b>RSI</b>	Received Signal Strength Indicator
<b>RSU</b>	Road-Side Unit
<b>SCH</b>	Service Channel
<b>SLAM</b>	Simultaneous Localisation and Mapping
<b>SOTIS</b>	Self-Organizing Traffic Information System
<b>SPD</b>	Speed

<b>STDMA</b>	Self-organizing Time Division Multiple Access
<b>TCP</b>	Transmission Control Protocol
<b>TDOA</b>	Time Difference of Arrival
<b>TOA</b>	Time of Arrival
<b>UDP</b>	Universal Distribution Protocol
<b>V2I</b>	Vehicle-to-Infrastructure
<b>V2V</b>	Vehicle-to-Vehicle
<b>VANET</b>	Vehicular Ad-Hoc Network
<b>VEINS</b>	Vehicles in Network Simulation
<b>VESOMAC</b>	Vehicular Self-Organizing Medium Access Control
<b>WAVE</b>	Wireless Access in Vehicular Environments
<b>WIFI</b>	Wireless Fidelity
<b>WRA</b>	Wave Routing Advertisement
<b>WSA</b>	Wave Service Advertisement
<b>WSM</b>	Wave Short Message
<b>WSMP</b>	Wave Short Message Protocol
<b>WSN</b>	Wireless Sensor Network



# Chapter 1

## Introduction

### 1.1 Overview

One of the scientific areas with the fastest development and continuous innovation that has an enormous global impact on the economy, society and the environment is wireless communications. The research and development of wireless communication technologies have especially been intense in the last twenty years. During this time, different networking concepts have been designed, tested and implemented. Some of the well-known wireless technologies that are widely used include mobile cellular communications (2G, 3G, 4G, 5G), WiFi networks (802.11a/b/g/n/ac), Bluetooth, wireless sensor networks (WSN), etc. Nowadays, one of the latest topics in the wireless networking area is inter-vehicular communications, often referred to as IVC. IVC assumes communication between the vehicles which can be cars, busses, trucks or cycles. These vehicles can communicate in order to increase the safety and efficiency of everyday transport [1]. The concept of IVC is based on the vehicle-to-vehicle (V2V) and the vehicle-to-infrastructure (V2I) communications. In V2V communications the network is completely distributed and vehicles communicate only with other vehicles,

whereas in the V2I communications vehicles communicate with the network infrastructure, which can be base stations installed by local traffic authorities. Future applications will however most probably be based on a combination of these two communications types.

In the early days of IVC the research community proposed to use a couple of well-known communication standards for IVC. These were mobile communications standard 3G and the well-known WiFi standard 802.11a [2]. However, having in mind the importance of the potential IVC applications, the IEEE proposed and later adopted a standard dedicated to IVC. This is 802.11p [3], also known as the Dedicated Short-Range Communication Service (DSRC). The 802.11p standard is based on the traditional 802.11 standard, but it is modified in a way to better support the unique nature and scenarios of IVC. This standard enables formation of vehicular ad hoc networks, popularly referred to as VANETs, in which the nodes are vehicles. However, even with the amendment to better support real-time VANET applications, the use of this standard and its suitability is being questioned among researchers and some major concerns still exist [4]-[14].

Since VANETs are in general regarded as a subgroup of mobile ad hoc networks (MANETs) and have often been compared to wireless sensor networks (WSNs), there has been initial initiative to solve the research problems of VANETs by applying some of the solutions designed for MANETs and WSNs. Understandably, the reason for this is the existence of the number of already established research results obtained in the WSN and MANET areas and their similarities with VANETs. However, the research community agrees that the differences between these two types of networks are much more relevant than their similarities, which makes most of such proposals inappropriate for VANETs [15]. The most important difference is the application scenarios where these networks are deployed and the way of their use. In MANETs and WSNs, the nodes' mobility is fairly limited and they are usually power constrained, thus most of the protocols were designed

considering these factors as the most important priorities. On the other hand, in VANETs, the nodes are moving faster on predefined roads and without any power constraints. Additionally, in WSNs the nodes are supposed to collect the information and send it to the local sink, which is not the case with VANETs. In VANETs, all the nodes are sinks and the goal of the network is to provide the drivers/vehicles with some useful real-time information about conditions in the traffic. Thus VANETs require development of dedicated solutions which are able to support VANET-specific scenarios and applications.

The communications paradigm of VANETs is based on the exchange of messages between the vehicles, which usually contain some traffic related information such as the level of congestion, information about accidents, weather, etc. The type of information and the actual content of the messages depends on the specific application and it is obtained from the vehicle's on-board systems and different types of sensors. Even though the applications for VANETs are still not fully standardised, the research community agrees that they can roughly be divided into safety and non-safety categories [15]. The safety category includes the applications that are envisaged to increase the safety in traffic, and some example applications might include collision avoidance and collision detection. Non-safety applications are often referred to as comfort applications and some potential examples include: traffic congestion management, parking assistance, infotainment and advertising. Obviously, in order to develop such applications, it is necessary to enable the vehicles to exchange the messages in an efficient and scalable manner to reach as many vehicles as possible. Because of its very dynamic nature and high node mobility, VANETs represent a very challenging communications environment. Having in mind it is still a relatively young research area, the research community recognises a number of challenges and problems in different domains of VANETs, including routing protocols, security frameworks, quality of service, and broadcasting [16].

## 1.2 Research contribution

The aforementioned research domains in VANETs are significantly affected by the poor performance of the MAC layer of IEEE 802.11p which particularly stands out as a serious concern for the successful future application of VANET technology [4]-[14]. This problem is especially serious when the number of vehicles in the network (i.e. high load) and consequently the applications they use is high. Alleviating this problem can be achieved in a number of ways, including the development of a new medium access technology for VANETs. Another way is the optimisation of the existing MAC layer to better support critical scenarios in VANETs. Alternatively, some of the well-known mechanisms which reduce the load on the MAC layer can be applied to avoid compromising MAC performance. Since the standard is already adopted, the first two options are not viable solutions, and application of mechanisms which can reduce the network load presents a much more promising option. Such mechanisms include data aggregation, adaptive broadcasting and clustering. These are well-known for reducing the network load by decreasing the number or size of exchanged messages within the network. Having in mind the paradigm of VANETs communications, data aggregation stands out as a content-aware mechanism which is extremely important for VANETs.

The motivation of our work comes from the need for efficient and scalable distributed protocols for the distribution of neighbourhood information using VANETs. The main aim of our solution is to use data aggregation algorithms to increase scalability without compromising the accuracy of the communicated network information. This thesis presents an intelligent, location-aware (*LA*) data aggregation mechanism for real-time observation, estimation and efficient data dissemination of messages in VANETs based on a generic modelling approach which supports operation of any VANET application. The main contributions of

the proposed scheme are:

- Significant reduction of the communication load of a fully distributed VANET, whilst retaining the accuracy of disseminated information on acceptable level.
- The proposed mechanism does not require advanced localisation systems like GPS and digital maps, and is applicable to any vehicle with VANET capability. This makes it independent on advanced localisation systems which are still not widely available in the vehicles.
- The mechanism enables dynamic segmentation of roads based on their direction. The segments serve as a flexible aggregation structure which is used in data aggregation process. Such dynamic segmentation is further used for efficient spatio-temporal indexing for vehicle's database, whose size is fixed and does not increase in time. As a result the database maintenance is very cost effective without the need for storing information about all street segments of an urban area. This approach makes the comparison of aggregates and single observations possible, which contributes to higher accuracy. The database is being constantly refreshed which solves the problem of old information in aggregates, thus providing only fresh information.
- Generic design of the *LA* mechanism provides broad application support regardless of the type of data contained within the exchanged messages. Moreover, it is able to accommodate the requirements of both urgent and periodic applications.
- Optimal fusion mechanism using the Kalman filter which estimates the real and optimal state based only on latest received measurement. The filter removes the noise and smooths the observed values, making them convenient for monitoring purposes.

## 1.3 Structure of the thesis

The thesis is organised into seven chapters:

- Chapter one provides the overview of the research and states the contribution of this thesis.
- The second chapter introduces VANETs together with the standardisation work in the area and some existing research problems that served as the initial motivation for this research.
- Chapter three presents data aggregation as one of the techniques for addressing the aforementioned research challenges in VANETs. Data aggregation is introduced as a concept firstly used in WSNs and then relevant works in VANETs area are presented. Comparative analysis is performed together with outlining of the challenges in this specific area.
- Chapter four presents improved modelling approach to design of generic data aggregation mechanisms that can solve one or more challenges introduced in the previous chapter. This chapter also presents the main contribution of this thesis, the location aware data aggregation for efficient message dissemination in VANETs, referred to as the *LA* mechanism.
- Chapter five introduces a complex simulation environment and evaluation performed to analyse the performance of the mechanism.
- The sixth chapter concludes the thesis and summarises the main contributions.
- Chapter seven provides the list of publications that were published during this research and introduces potential future research that can be performed on top of the research presented in this thesis.

# Chapter 2

## Vehicular Ad-Hoc Networks

### 2.1 Introduction

Mobile Ad Hoc Networks (MANETs) are infrastructure-less wireless networks, consisted of autonomous mobile nodes. This type of networks is an alternative to classic infrastructure-based type of wireless networks, which require supporting infrastructure and wired connections to be fully operational. In MANETs the nodes are connected via wireless links and are thus independent of any type of fixed infrastructure. Therefore, they can be easily and flexibly deployed in almost any environment (e.g., conference rooms, forests, battlefields, etc.) without the need of centralised administration.

The nodes in MANETs are typically mobile and able to maintain connection on the move and act as routers autonomously. That means they are free to move randomly and organise themselves arbitrarily in an ad-hoc manner which is why network topology may change rapidly and is totally unpredictable. As shown in Figure 2.1, a mobile ad-hoc network might consist of several types of devices such as laptops, PDAs, smartphones. Each node can communicate directly with

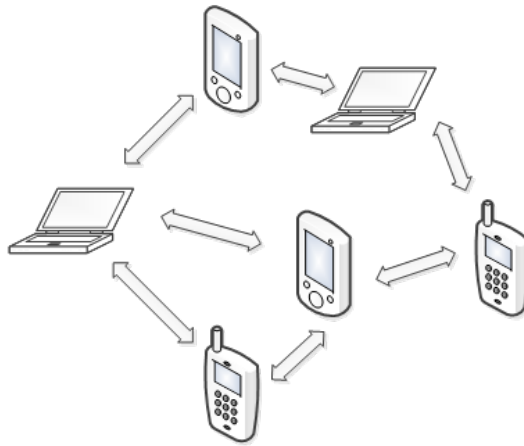

Figure 2.1: Mobile ad-hoc network (MANET).

other nodes within its communication range. For communication with nodes out of the communication range, the nodes use intermediate nodes to relay messages hop by hop. This type of networking eliminates the constraints of infrastructure and enables devices to create and join networks anytime and anywhere for any application.

One practical and popular concept of MANETs is wireless sensor networks (WSNs). In WSNs the nodes are additionally equipped with one or multiple sensors that measure some natural phenomenon, for example, temperature, pollution level, noise or radiation. In a particular application, the nodes are placed in a specific area where they collect the data about the phenomenon and communicate the data to the sink node, which collects it and processes it [17]. In such applications the time is usually not the limiting factor, thus the processed data is not required in real time by the users of the application. Even though the nodes in WSNs are strictly speaking mobile, their mobility is fairly limited. Additionally, the processing power and the power supply of the nodes are also very limited, thus most of the protocols for WSNs are designed with these limitations in mind [17].



Another sub-category of MANETs is vehicular ad-hoc networks (VANETs), where the nodes are placed on vehicles such as cars, bicycles or buses [16], as shown in Figure 2.2. Vehicles are then able to communicate with other vehicles via vehicle-to-vehicle communications (V2V) or with some fixed infrastructures such as roadside units (V2I). The general concept of communicating vehicles is often referred to as inter-vehicle communications. This communication paradigm enables the exchange of any type of information that might be used to support drivers on the road and make their travel safer and more efficient. Some common applications proposed for VANETs include safety applications, traffic management and infotainment.

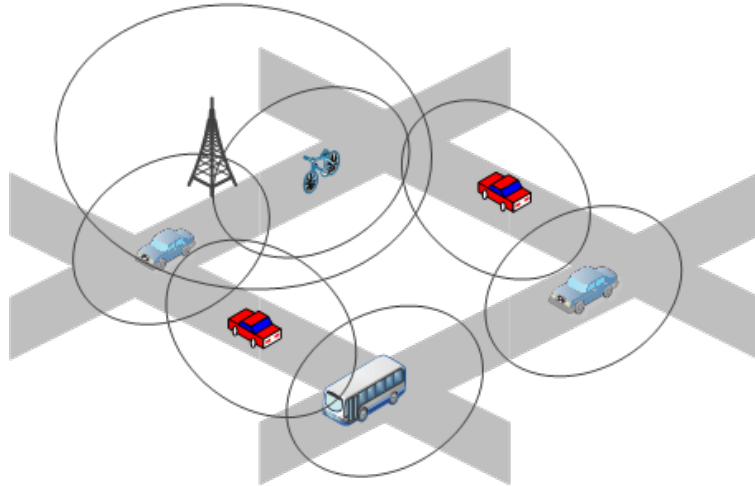

Figure 2.2: Vehicular Ad-hoc network (VANET).

## 2.2 Standardisation

To enable such applications, the first requirement is to select a suitable standard that can assure the operation of applications which are used by the highly mobile vehicles. The standard was required to cope with hostile propagation environments such as urban areas. In the early beginning of the research in this area, the use of traditional IEEE 802.11 and 3G standards were proposed and evaluated.

Both of these had some drawbacks that would represent the limiting factor in their use in VANET applications. IEEE 802.11 was not really tailored for use in networks with highly mobile nodes, thus its performance was not satisfactory. Since it is not an ad-hoc standard, the 3G was considered only for V2I communications. The main problem here would be high costs charged by mobile operators, making it unsuitable for VANETs.

In order to make inter-vehicular communication transparent and to enable interoperability between different manufacturers, the Dedicated Short Range Communications (DSRC) standard was created [3]. It is a set of standards and protocols adopted specifically for use in VANETs enabling short to medium-range communications in both V2V and V2I scenarios, for various applications including safety, traffic management and infotainment. An extensive survey of the standard can be found in [18] and we will outline here the major points from that paper. The primary motivation for the DSRC development was increasing the traffic safety by reducing the collision avoidance via inter-vehicle communications. In such applications vehicles periodically broadcast messages that contain their location and mobility information such as speed and direction. The vehicles then become aware of the presence of other vehicles in their vicinity. Therefore, every vehicle can calculate trajectories of surrounding vehicles and potential collisions, and can warn the driver accordingly.

The DSRC protocol stack is shown in Figure 2.3 [18]. The protocol stack includes physical layer (PHY), data link layer (including MAC), Network/Transport layer and application layer. DSRC uses IEEE 802.11p, often referred to as Wireless Access for Vehicular Environments (WAVE). IEEE 802.11p was chosen for DSRC based on the fact that traditional IEEE 802.11 (a, b, g, n) are the most widely used wireless local area network standards in the world. Because of that, the supporting equipment comes at a low price.

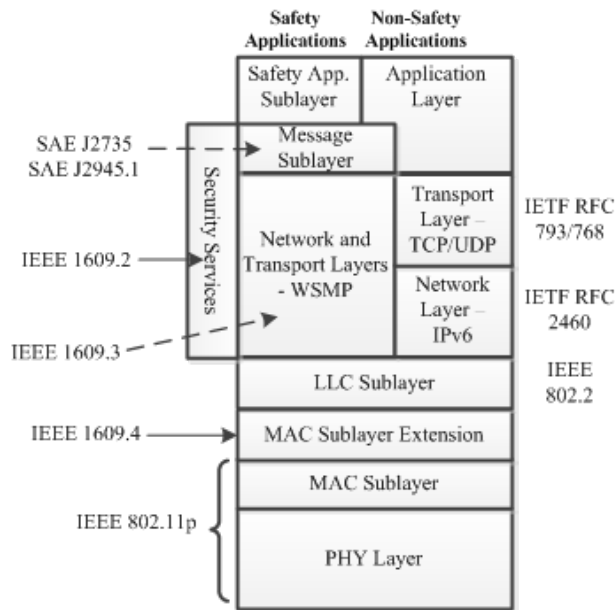

Figure 2.3: DSRC protocol stack.

Additionally, the majority of network simulators supports the 802.11 standard thus making the evaluation of the standard in VANETs scenarios easy and convenient. However, 802.11p differs from the previous set of 802.11 standards, with changes in its MAC and PHY layers in order to better suit the high mobility scenarios found in VANETs. IEEE 802.11p is divided into the physical medium dependant (PMD) layer and the physical layer convergence procedure sublayer (PLCP). The middle of the DSRC protocol stack is reserved for the standards developed by the IEEE 1609 Working Group. These include: 1609.4 for channel switching, 1609.3 for network services and 1609.2 for security services. It is worth mentioning that under the 1609.3 set of standards, there is a WAVE Short Message Protocol (WSMP) defined as well. Additionally, DSRC supports traditional Internet protocols in Network (IPv6) and Transport Layers (TCP/UDP). Usually, many VANETs applications use WSMP over traditional TCP/IP protocols because it is bandwidth friendly and is more suitable for VANETs case scenarios. This is because the communication in VANETs is in one-to-all manner, whilst the applications that require routing use traditional TCP/IP protocols [18]. Additionally the stack contains the SAE J2735 Message Set Dictionary standard that

specifies the format of the messages for various VANETs applications. One of the most important message types is the basic safety message (BSM). The SAE J2735 protocol defines the syntax only whilst the other norms will be specified in the upcoming SAE J2945.1. In the following text we will introduce the main characteristics of individual layers within DSRC protocol stack together with their main features.

IEEE 802.11p is based on OFDM, with channel width of 10MHz, unlike 802.11a which is based on channels of 20MHz. OFDM divides an input data stream into a set of parallel bit streams and then each bit stream is mapped onto a set of overlapping orthogonal subcarriers for data modulation and demodulation. The orthogonal subcarriers are transmitted simultaneously. Dividing a wider band into many narrow band subcarriers ensures that a frequency selective fading channel is converted into many flat fading channels over each subcarrier. Additionally equalisation may be used at the receiver to alleviate inter-symbol interference. Four modulation schemes are used, including BPSK, QPSK and QAM (16 and 24) and specifications of data rate options and basic OFDM characteristic are shown in Table 2.1.

Table 2.1: Overview of DSRC specifications.

Parameters	IEEE 802.11p
Bit rate (Mbit/s)	3, 4, 5, 6, 9, 12, 18, 24, 27
Modulation mode	BPSK, QPSK, 16QAM, 64QAM
Code rate	1/2, 2/3, 3/4
Number of subcarriers	52
Symbol duration	8 $\mu$ s
Guard time	1.6 $\mu$ s
FFT period	6.4 $\mu$ s
Preamble duration	32 $\mu$ s
Subcarrier spacing	0.15625 MHz

Apart from the physical layer configurations the standard also specifies the classification of devices according to the maximum radiated power, which also determines the coverage. This classification is shown in Table 2.2.

Table 2.2: 802.11p Devices Classification.

Device class	Max Out. Power (dBm)	Communication Zone (meters)
A	0	15
B	10	100
C	20	400
D	28.8	1000

The spectrum allocation is specified depending on the location and mainly there are three specifications: US, Europe and Japan. In 1999, the Federal Communications Commission (FCC) allocated 75 MHz of licensed spectrum, from 5.85 to 5.925 GHz, as part of the Intelligent Transportation System (ITS) to use for Dedicated Short Range Communications (DSRC) in the United States. This bandwidth is divided into seven 10 MHz channels and 5 MHz guard band at low end. Additionally, two 10 MHz channels can be used as one 20 MHz channel as well, but individual 10 MHz channels are more suitable in reference to the Doppler effect problem [18]. On the other hand, in Europe, the European Telecommunications Standards Institute (ETSI) allocated 30 MHz of spectrum between 5.875 to 5.905 GHz for safety applications use. For the non-safety applications ETSI allocated spectrum between 5.855 to 5.875 GHz, while the spectrum between 5.905 to 5.925 GHz is reserved for the future ITS applications. Worldwide DSRC spectrum allocation is shown in Figure 2.4.

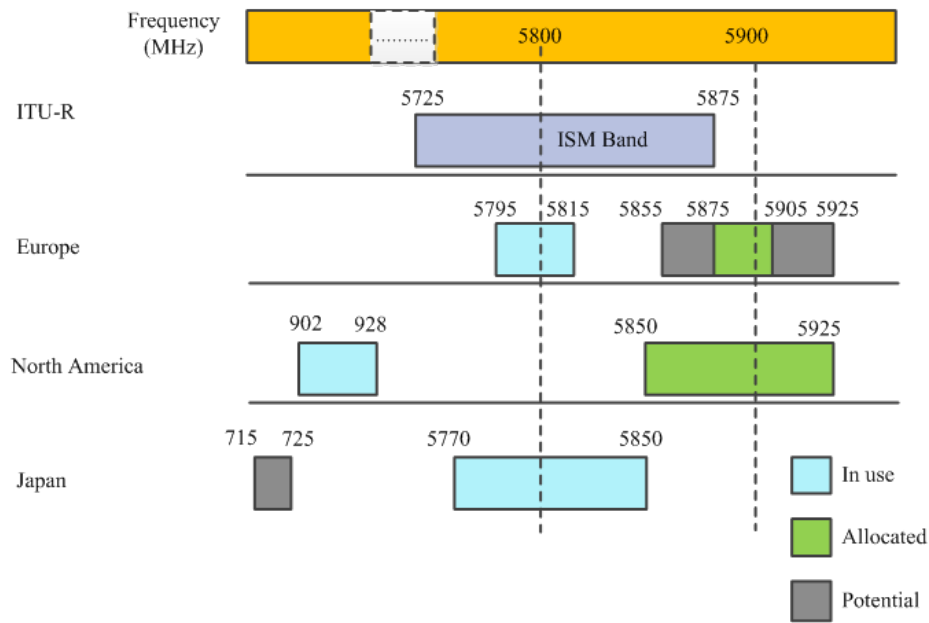

Figure 2.4: DSRC spectrum allocation.

According to channel distribution shown in Table 2.3 there are two types of channels: Service Channel (SCH) which is channel 178 and Control Channel (CCH) which are all remaining channels.

Table 2.3: Channel Distribution 802.11p.

Channel Number	Central Frequency (MHz)	Bandwidth (MHz)	RSU EIRP max. (dBm) Pub./Priv	OBU EIRP max. (dBm) Pub./Priv
172	5860	10	33/33	33/33
174	5870	10	33/33	33/33
175	5875	20	23/33	23/33
176	5880	10	33/33	33/33
178	5890	10	44.8/33	44.8/33
180	5900	10	23/23	23/23
181	5905	20	23/23	23/23
182	5910	10	23/33	23/23
184	5920	10	40/33	40/33

Data link layer of 802.11p is also divided into two sublayers: Medium Access Control (MAC) sublayer and Logical Link Control Sublayer (LLC). The MAC layer is responsible for enabling the nodes to access the wireless medium based on a certain set of rules, divided into two categories: session based rules and

frame by frame rules. The session based rules define steps that each node is taking to access the medium whilst frame by frame rules specify an individual transmission.

Out of these two categories of rules only the session based set of rules is amended in IEEE 802.11p compared to IEEE 802.11a. Within session based rules, there is a Basic Service Set (BSS) concept defined and it defines the set of nodes that belong to the same network. There are two types of BSS: infrastructure based and independent. In infrastructure-based BSS there is a so-called Access Point (AP) to which all the mobile nodes are connected and serves as a gateway to some other network and services, for example the Internet. Independent BSS has no AP and only mobile nodes form a network. The process of establishing a BSS both in infrastructure based and independent BSS assumes certain procedures between the mobile nodes and in infrastructure based BSS with AP as well, such as BSS announcement, joining, authentication and association. These processes do require a certain amount of time to be performed, and therefore they induce a certain level of delay which might be an issue for VANETs where nodes are moving with high relative velocities. Therefore the new concept of communication is introduced called “outside the context of BSS” (OCB). Since in traditional 802.11 all the data is communicated between the nodes within the same BSS, OCB is limited to communication between the nodes that do not belong to a BSS. IEEE 802.11p requires that the nodes in the network operate in OCB manner. Another difference in OCB is there is no MAC synchronisation. The synchronisation is used for power management in traditional MANETs, which is not the issue in VANETs. Additionally, there is no traditional authentication in MAC layer, but it is done in upper 1609 layers. Finally, in OCB there is no association like in infrastructure based BSS.

To access the medium, the MAC protocol specifies the set of rules that vehicles need to obey based on Carrier Sense Multiple Access/Collision Avoidance

(CSMA/CA). According to this set of rules, the node that wants to send a frame first senses the medium. In case the medium is idle, the node sends the frame, and in case it is busy, the node goes into a back-off procedure whereby it waits for a random number of time slots before transmission. The waiting process is done when the medium becomes idle. Below we continue presenting the DSRC set of protocols, moving to upper layers including 1609.4, 1609.3 and 1609.2.

The 1609 group of standards relates to three functions, including multi-channel operation (1609.4), networking services (1609.3) and security services (1609.2). As per Figure 2.3, above LLC sublayer, DSRC protocol stack is split in two parts, one using WAVE Short Message Protocol (WSMP) defined in 1609.3 and second using traditional internet protocols (TCP, IP and UDP). The first part is optimised for sending of non-routed messages as typically sent in VANETs [18]. The second part is optimised for routing messages, and which of the two parts of the stack is used depends on the application or service design.

IEEE 1609.4 allows multichannel operation by specifying the management extension to MAC that enables the operation among multiple channels. Seven adopted channels in DSRC spectrum are divided into six Service Channels (SCH) and one Control Channel (CCH). With time division paradigm the node operates in both SCH and CCH by periodically switching between them. The time switching is based on alternating service and control intervals, so called “sync periods” of 100 ms. The CCH is used for advertising services and specifies the SCH on which the service is available. Finally CCH is used for sending of safety WSMP messages and IP packets are not allowed on CCH. Additionally, there is a consensus that SCH 172 is to be used for collision avoidance messages, without time division [18].

Even though the DSRC protocol stack supports traditional IP, TCP and UDP protocols, which support routing capability, this capability is not so im-



portant for VANETs. This is mainly because all the vehicles in the network are interested in receiving the information from their neighbours, thus most of the messages are sent via WSMP protocol. The IEEE 1609 Working Group introduced new Layer 3 protocol suitable for 1-hop communications (the WSMP protocol) which associates less packet overhead than TCP/IP approach. Since the channel congestion is significant concern in DSRC, the use of WSMP protocol is preferred because the overhead is lower than in traditional TCP/IP protocols. The packets sent via WSMP protocol are called WSM messages and their structure is shown in Figure 2.5.

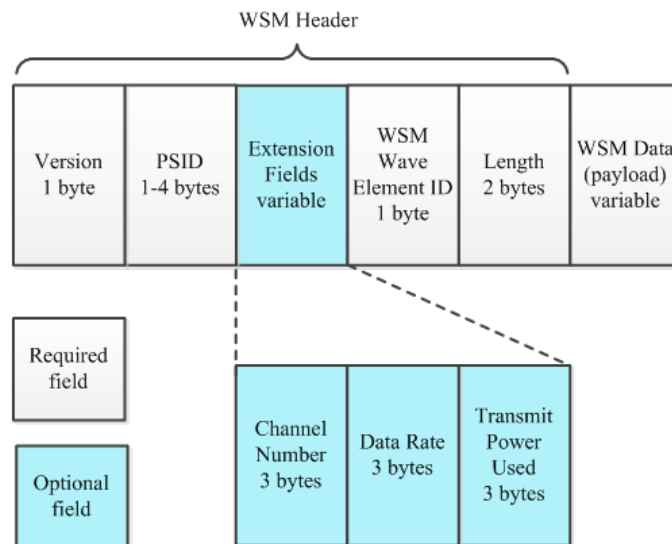

Figure 2.5: WSM message structure.

The structure of WSM message includes a variable header necessary for the operation of the WSMP protocol and variable payload which depends on the application type. We briefly introduce all the fields within WSM message:

- Version (1 byte) – Mandatory WSMP version number, currently set to 2.
- Provider Service Identifier (PSID) (1-4 bytes) – Mandatory identifier of the service that WSM data belongs to. Device maintains a list of all the active services at higher layers and processes the received message only if received PSID is on the list of active services.

- Extension Fields (variable) – These fields are optional and can include Channel Number (3 bytes), Data Rate (3 bytes) and Transmit Power Used (3 bytes).
- WSM Wave Element ID (1 byte) – Mandatory field which indicates the end of extension fields and format of WSM Data field.
- Length (2 bytes) – Mandatory byte marks the end of WSM header and its value is equal to the number of bytes within the WSM Data field and can have values between 0 and 4095 bytes.
- WSM Data (Payload) (variable) – This field includes the data used within the application and is determined by the higher layers.

The basic type of WSM messages is Basic Safety Message (BSM), or popularly called beacons. These messages are used to increase traffic safety and reduce accidents by enabling the drivers to be aware of other vehicles in their neighbourhood even if they do not see them. The content of these messages usually includes some basic parameters about vehicle's mobility and location, such as speed, direction, ID of the vehicle, location coordinates. With such parameters vehicles can participate in a collision avoidance application. Apart for these purposes, WSM messages can generally be used for sharing any other type of data between vehicles, for example for traffic management purposes, parking discovery or infotainment. These applications are called services for which the messages are exchanged on SCH and advertised on CCH via Wave Service Advertisement (WSA). It should be noted that beacons are not considered as services, thus they are not advertised as WSA since they are mandatory. One device can support up to 32 services and they can all be advertised in the WSA. Additionally, the services can be supported by both WSMP and TCP/IP protocols. The structure of the WSA message is shown in Figure 2.6 and the fields of WSA include:

- WAVE version/Change count (1 byte) – It contains the version number of WSA and a counter which is incremented when the content of WSA is updated to enable the nodes to remove duplicate WSAs.
- WSA header extension fields (variable) include: Repeat Rate, Transmit power used, 2D Location, 3D location and confidence, Advertiser identifier, Country String.
- Service info (variable): the fields where the services are advertised and each of the fields advertises one service.
- Channel info (variable): the service info fields are connected to channel info fields in a way that there is dedicated channel info field for every channel on which service info is advertised.
- WAVE Routing Advertisement (WRA) (variable): an optional field within WSA when the service uses IPv6 protocol stack instead of WSMP.

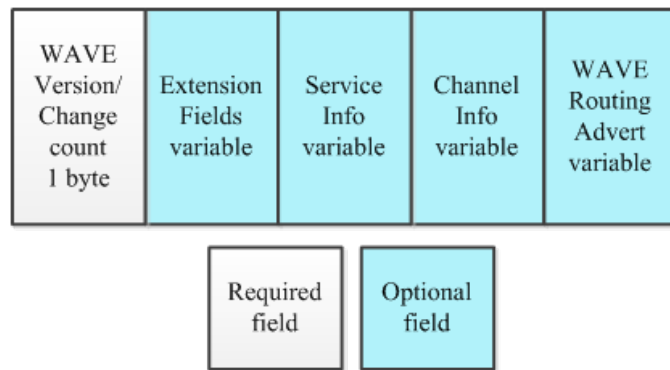

Figure 2.6: WSA message structure.

Finally, it is worth mentioning that in case the node is running multiple applications with different QoS requirements in a multi channel operation, different QoS classes are obtained by prioritising the data traffic within each node. Each channel has four different Access Categories (AC0-AC3) defined for four different priority levels, with AC3 having the highest priority. These data frames

are therefore first contenting internally for the access and only then are allowed to content with other nodes for the wireless medium.

This section introduced the concept of VANETs and the set of standards serving as grounds for development of future applications. The potential examples of applications and scenarios were outlined to understand the motivation and objective of the technology. Additionally, this section is mandatory to comprehend the major research challenges in this area, that are presented in the following Section 2.3.

## 2.3 Challenges and initial research motivation

This section discusses some of the challenges of the DSRC standard, and therefore VANETs as well, which serve as a primary motivation for this research. There are a number of quality survey papers about VANETs, the standards used, proposed solutions and protocols [16], [19]-[22]. All of them mostly agree about the direction that future research needs to take to enable the successful adoption and implementation of this technology in the near future. In this section, we introduce relevant works and explain their concerns which serve as a primary motivation of this research.

Some of the challenges in VANETs include routing protocols, security frameworks, quality of service, broadcasting [16], etc. One of the problems in VANETs that particularly stands out and significantly impacts the aforementioned challenges is the connectivity in VANETs. Its origins lay within the design of IEEE 802.11p and the VANET-specific application and network scenarios. As explained in Section 2.2, this standard was derived from the 802.11a standard, which was originally designed for MANETs, where nodes' mobility is relatively low. Even after its amendment for VANETs applications, the performance of the CSMA/CA-

based MAC layer has often been questioned throughout the literature [4]- [14]. In this section the works that evaluated the performance of 802.11p together with their conclusions about the existing issues with the standard are reviewed.

In [4] the authors evaluated the capabilities of the DSRC standard in order to find its limitations. They argue that with the increasing number of sending vehicles the collision probability significantly increases. This causes many “dead times” when the channel is blocked, but no useful information is exchanged. This is even worse in the case when the channel switching between SCH and CCH is used since they use different packet queues. Then the CCH messages queue up during the SCH intervals, which causes long queues and higher end-to-end delays. The authors conclude that in the dense scenarios the technology does not ensure dissemination of time critical messages and propose additional mechanisms to be used to reduce the number of high priority messages. Additionally, they suggest the tuning of EDCA parameters to relieve the high probability of collisions.

Authors of [5] evaluated the ability of the DSRC standard to enable the real time communication in VANETs and agreed that unbounded channel access delays and collisions on the wireless channel are well-known problems of the CSMA/CA-based MAC of DSRC. This is especially evident when the node density is increased and the scalability of CSMA/CA is compromised. When the node density increases, CSMA/CA has huge troubles with solving all channel access requests. In [6], in another evaluation, authors outline severe performance degradation in the case of a high-density network, both for the individual nodes and for the system as a whole. Authors of [6] claim that 802.11p is unsuitable to support applications that require periodic messages, especially in a highway scenario when the range, message size and its periodicity is high. According to their evaluation, some nodes drop over 80% of their data packets. To address this issue authors suggest using smaller messages with less frequent broadcasting. As a main drawback of CSMA the authors of [6] outline its unpredictable

behaviour, meaning that access delay is unconstrained since nodes could experience unbounded delays due to collisions. Similarly, the work in [7] examines the scalability issues in VANETs and concludes that due to CSMA/CA medium access, the limited available bandwidth is even further reduced because of the poor channel utilisation. Authors of [7] also state that controlling the network load is the most important challenge for the operation in dense networks. They outline that the main cause of the large amount of messages in the medium is the number of contenting vehicles and number of applications used in the vehicles. In [8], the authors evaluated the overall capacity and the delay performance of VANETs using 802.11p. Their results show the traffic prioritisation scheme of the standard works well even in the case of multichannel operation and that delay of control messages which have the highest priority is of the order of tens of milliseconds. However, they conclude that when the traffic load is reaching 1000 packets per second the delay is increasing extensively.

An analytical model for the performance evaluation of the IEEE 802.11p MAC sublayer was introduced and evaluated in [9]. It showed that 802.11p enables effective service differentiation mechanism based on enhanced amendment of 802.11p for VANETs. However, the authors agree that the support of bandwidth-consuming applications is still challenging problem from a resource allocation perspective. This results in a poor performance in high density networks. Authors of [10] argue that the main problem is that the channel estimation mechanisms built within 802.11p standard assumes channel estimation at the beginning of each packet. Since the packet length is not restricted by the standard, the authors point out that the initial channel estimate can expire prior to the transmission of the packet. This brings the need of updating the channel throughout the length of the packet and according to the authors, the standard does not have enough pilot structure to make this condition possible. Addressing this issue is shown by introducing the dynamic channel equalization scheme STA. Like most

of the previously cited authors, here as well they agree that packets should be shorter in order to minimise the PER. The authors conclude that to maximise the throughput there needs to be a trade-off between high overhead at short packet lengths and poor performance at longer packet lengths. In [11] the performance analysis of medium access in 802.11p was conducted while considering the specific conditions of the control channel of a WAVE environment. The authors focus on the evaluation of QoS metric parameters such as throughput, losses, buffer occupancy and delays. In some cases, the authors show that throughput is increased at the cost of increasing frame delays. Authors of [12] researched the MAC features of 802.11p and its throughput performance and showed the specified MAC parameters in this protocol might bring undesired throughput performance. This is due to the fact that back-off window sizes are not adapted to the dynamics of change in number of vehicles which are trying to communicate and content. To address this issue they even suggested centralised and distributed approach for the vehicles to adaptively adjust window size based on channel feedback to secure higher throughput.

The work in [13] deals with performance evaluation of both DSRC and LTE standards and their ability to support VANETs. The authors developed a number of experiments and analytical models with simulations. They conclude that in the case of 802.11p, increasing the size of contention window helps to improve the reliability of beaconing, although this also comes with a big limitation. For large values of contention windows, beacons are lost, both because of collisions and because the CCH interval has expired. Additionally, the authors are positive that LTE is hardly able to support beaconing in VANETs for safety applications because of its poor performance. In such a case, the network easily gets overloaded even when the scenario is ideal and simplified. Finally, the authors of [14] believe that the 802.11p standard is a viable candidate for use in VANETs based on the analysis they performed which also outlined the limitations of the technology as

well. They argue that the average delay, according to standards is acceptable for different applications. However, they also emphasise a serious problem in scenarios with higher data rates which cannot ensure the dissemination of time critical messages.

Addressing the aforementioned problems has been a hot research topic lately. Some of the more drastic approaches include proposals for either a completely new MAC layer to be used in VANETs or concepts for optimisation of the existing MAC scheme by tuning some of the parameters such as the EDCA parameters. An extensive survey of such proposals can be found in [23], and here we briefly introduce some of the proposals. One of the most well-known solutions proposed as an alternative to CSMA/CA in 802.11p is the Self-organising Time Division Multiple Access (STDMA) scheme proposed in [5] as a remedy to the CSMA scaling problems. This algorithm is already in commercial use in the maritime industry where it is called the Automatic Identification System (AIS). This system is used for collision avoidance between the ships. The authors of [5] firstly analysed the requirements of safety applications for real-time use. They argue that STDMA is predictable, a decentralised MAC method which has finite access delays and thus it is suitable for real-time VANETs applications. Further, it is stated that the ad hoc network with the real-time constraints requires decentralised and predictable medium access technique capable of meeting these real-time deadlines. CSMA and STDMA were compared in regards to the channel access delays and interference caused by collisions in a highway scenario. By using CSMA, some vehicles will become invisible to surrounding vehicles for periods up to 10 seconds whilst on the other hand STDMA always allows packets channel access. This is because the slots are reused if all slots are currently occupied. Moreover, a node chooses the slot that is used by a node located further away. Therefore, STDMA ensures that there are no dropped packets from the sending side and channel access delay is fairly small and bounded. Finally, the authors



conclude that the probability of having the small distances between the closest interfering nodes is higher in case of CSMA than STDMA, which indicates that CSMA has a worse packet collision problem than STDMA.

Another proposition for the MAC issues in VANETs is VeSOMAC, presented in [24]. Similarly to STDMA, VeSOMAC is based on TDMA and self-configuration. It features an in-band control mechanism, which exchanges information about the TDMA slots during distributed MAC scheduling. The authors claim that its in-band control mechanism is suitable for fast protocol convergence while vehicles move and topology changes. The performance evaluation shows that VeSOMAC enables better file transfer performance than 802.11p due to its enhanced TCP throughput and fewer dropped packets in MAC.

In [25] a multi-channel token ring MAC protocol (MCTRP) for inter-vehicle communications was presented. It uses adaptive ring coordination and channel scheduling, to autonomously organise vehicles into multiple rings operating on different service channels which enables the dissemination of emergency messages with low delays. Additionally, the network throughput for non-safety messages is further improved with the token based data exchange protocol. The authors developed and simulated analytical model for performance evaluation of MCTRP, and parameters observed include the average full ring delay, emergency message delay, and ring throughput. Results show that MCTRP quickly disseminates emergency messages to nearby vehicles, the throughput in dense networks is significantly improved by dynamic allocation of SCHs allocation and it reduces the channel access time of each node.

Finally, DMMAC [26] introduces an adaptive broadcasting mechanism, designed to enable transmissions without collisions and bounded delays for safety applications under various traffic scenarios. Its adaptation is based on a dynamic length of TDMA on CCH intervals. Results show that DMMAC shows better

results than the current WAVE MAC when delivery ratio of safety messages is observed.

Section 2.3 introduced one of the biggest concerns about the technology that is supposed to enable the implementation and operation of VANETs, the 802.11p standard and its CSMA/CA MAC layer. Consensus exists in the research community that the main problem with 802.11p is its inability to handle large communication requirements of the nodes when their number in network is high. This happens because the nodes in wireless networks communicate by physically broadcasting the messages. Depending on the fact who is the intended recipient of the message there are various types of communication such as uni-cast, multi-cast, geo-cast, etc. The vehicles will be equipped with omnidirectional antennas, meaning the broadcasted messages will propagate in all directions and the vehicles that are in range will receive them. The underlying networking problem is the broadcast storm problem, which arises when many nearby nodes try to transmit messages and use the same channel for broadcasting. Such situations are very common in VANETs, especially in the urban and highway scenarios, where the number of nodes can easily reach hundreds or even thousands. This is exactly the case in VANETs, because all the nodes use the same SCH for one application causing many packet collisions, dropped packets, and intense contention activity between the vehicles. Finally, as the direct consequence of the broadcast storm and the hostile communication environment, the network scalability is significantly compromised. Scalability is defined as the ability to handle the addition of nodes or objects without suffering a noticeable loss in performance or increase in administrative complexity [7].

Addressing the broadcast storm and scalability problems can be grouped in a single problem of communication efficiency. As an alternative solution to changing the MAC layer in VANETs to improve the communication efficiency, there are some well-known concepts and techniques such as data aggregation, adaptive

broadcasting and clustering. Communication efficiency is extremely important for other network types as well, the most prominent of them being WSNs. Most of the proposals for WSNs are designed with communication efficiency in mind because of the network lifetime, since the nodes are power constrained. On the other hand, the communication efficiency in VANETs is required because of the scalability problems and efficient message dissemination.

Chapter 2 introduced the concept of VANETs, the underlying technology and standards together with its major concerns and research challenges. One of the main recognised research challenges of VANETs is its inability to handle dense network scenarios, due to the limitations in the medium access approach. This serves as the main motivation of this thesis to develop the data aggregation mechanism that contributes towards alleviation of this problem. The data aggregation is a concept of data processing that addresses the presented issues and aims to provide better scalability and communication efficiency for VANETs. The concept is presented in the following Chapter 3, together with the outlook on data aggregation mechanisms designed for VANETs.

# Chapter 3

## Data Aggregation

### 3.1 Introduction

One of the well-known techniques used to achieve communication efficiency in wireless networks is data aggregation. It is often used in WSNs to increase the network lifetime by reducing the amount of data communicated between the nodes since the nodes are power-constrained. It is a concept of data processing usually associated with data gathering and data dissemination performed by the nodes in the network [27]. There are many definitions of data aggregation available in the literature, and no consensus about a single and universal definition exists. Moreover, sometimes there is confusion in differentiating between data aggregation, data compression and data fusion. As defined in [28] data aggregation is “*the process of aggregating the data from multiple sensors to eliminate the redundant transmission and provide fused information to the base station*”. Authors of [29] define it as “*the global process of gathering and routing information through a multi-hop network, processing data at intermediate nodes with the objective of reducing resource consumption (in particular energy), thereby increasing the network lifetime*”. In [27] it is defined as a subset of information fusion that aims at

reducing the handled data volume by establishing appropriate summaries. All of these definitions agree that data aggregation creates the so called “aggregates”, which represent a summary of multiple data pieces. Exchanging these aggregates is more efficient than communicating the data pieces individually. Here, more efficient means that either the number of transmissions is reduced or the size of messages is reduced, or ideally both. Therefore, communicating a fewer number of ideally smaller messages also means fewer received messages and shorter processing times, thus directly impacting the efficiency in terms of both power consumption and communication. Extensive surveys of data aggregation mechanisms designed for WSNs can be found in [27]-[29]. These are out of the scope of this research, but we will present some of the most cited schemes and taxonomies, useful for discussing the topic in the context of VANETs. The first difference is that the power limit in VANETs is not the constraining factor, but the spectrum bandwidth definitely is. Then, in VANETs there is no intermediate nodes or hierarchy in the network and so called sinks. Instead, all the vehicles are generally interested in as much information as they can get and in a way they all represents network ”sinks”. Also, the nature of applications of WSNs and VANETs are very different, since the applications in WSNs are not necessarily real-time, whilst in VANETs they definitely are. These facts are the main reasons why data aggregation mechanisms for WSNs are hardly applicable into VANETs, thus new solutions should be proposed.

## 3.2 Data Aggregation in WSNs

In WSNs the nodes can be fairly mobile or static and are placed within an area in order to collect and exchange some data (typically some measurements). Apart from these nodes there is typically a base station or ”sink” which is required to collect the data from the nodes and process it in a certain way. The wireless

nodes use data aggregation to send the most relevant collected observations in an efficient and timely way to the sink. Efficiency depends on several factors, including network architecture, data-aggregation mechanism and the underlying routing protocol [15].

From the network architecture point of view, the data aggregation mechanisms can be grouped into two types: flat and hierarchical. In flat networks the function of each sensor node is the same and they are usually equipped with approximately the same power supply. The sink usually sends a query to the sensors and sensors which have the data matching the query, send the information back to the sink which performs data aggregation. Some of the existing flat architecture concepts include Push Diffusion, Two-Phase Pull Diffusion and One-Phase Pull Diffusion, all of which are further explained in [28]. The flat network approach might result in increased communication and computation activities at the sink node which can result in faster battery consumption and possible outage of the sink node, meaning the outage of the entire network as well. As an alternative to this approach, there is a hierarchical data-aggregation approach which assumes data fusion at some of the special sensor nodes as well. Therefore, in such a network not all the nodes are the same; there is an established hierarchy among them, which improves the energy efficiency of the network. One of the classifications of the hierarchical data aggregation mechanisms divides these into cluster-based, chain-based and tree-based mechanisms.

Since WSNs are energy-constrained, in large scale networks it is inefficient that individual sensors send data to the sink directly because of their number and the time the data takes to reach the sink. In such scenarios sensors can be organised into clusters, as shown in Figure 3.1, where each cluster has a cluster-head or local aggregator which aggregates the data and then forwards the aggregated data to the sink. This can be achieved either through a direct link with the cluster head or through multi-hop transmission via intermediating nodes. This results

in saving significant amounts of energy. Some of the well-known proposals based on this concept include: Low-Energy Adaptive Clustering Hierarchy (LEACH) [30], the Hybrid Energy-Efficient Distributed clustering approach (HEED) [31] and Clustered Diffusion with Dynamic Data Aggregation (CLUDDA) [32].

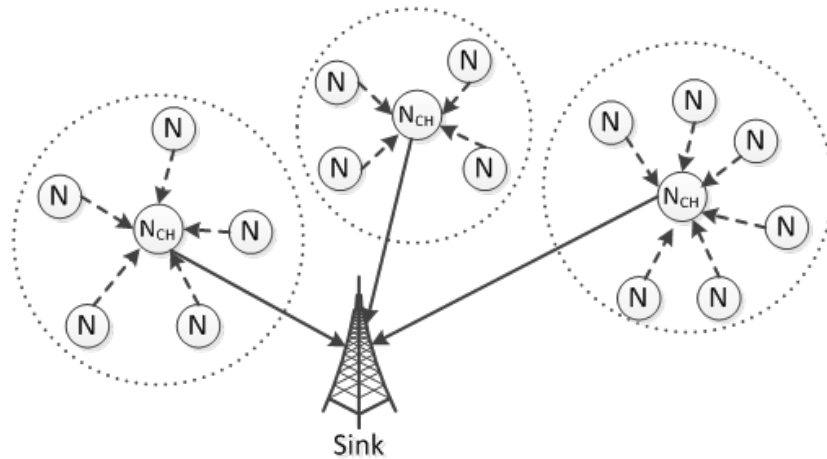

Figure 3.1: Cluster-based aggregation.

Another hierarchical solution is chain-based aggregation, Figure 3.2, which assumes that nodes transmit data only to the closest neighbours. A well-known example of this is Power-Efficient Data-Gathering Protocol for Sensor Information Systems (PEGASIS) [33], where the nodes are organised into a linear chain for data aggregation. The chains are formed using a greedy algorithm or they are determined by the sink in a centralised manner. However, forming a chain using a greedy algorithm assumes that the nodes have global knowledge of the network. The node farthest from the sink starts the chain formation and the closest neighbours of the nodes are the successors in the chain. When a node receives data from its neighbour, it fuses the data with its own. Finally, the leader node sends the data aggregated from all the nodes to the sink.

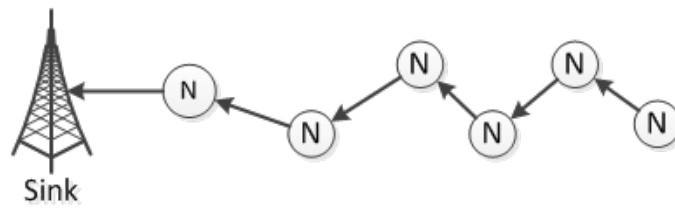

Figure 3.2: Chain-based aggregation.

Apart from the cluster-based and chain based approaches, there are also tree-based networks, Figure 3.3, where the sensors are organised in a tree and aggregation is performed along the tree, from the leaves to the root. One of the most prominent examples of such aggregation schemes is EADAT [34]. Finally, other than these structure based approaches, there are structure-free or hybrid approaches which might combine more of previously presented approaches. The structure free approach reduces the necessary communication needed to establish the structure such as cluster, tree or chain.

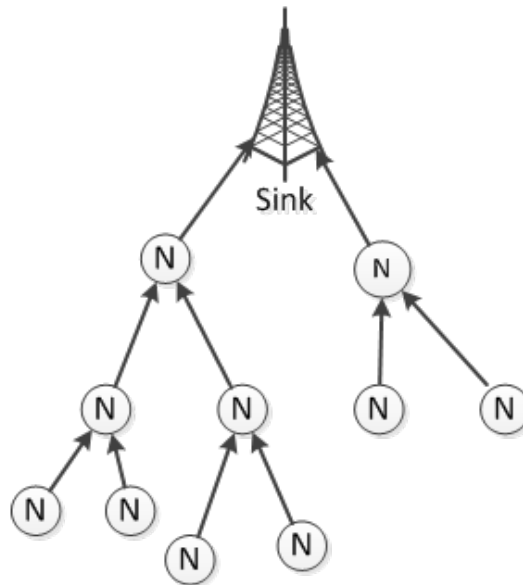

Figure 3.3: Tree-based aggregation.

Another important feature of the data aggregation process is the selection of suitable aggregation functions. The aggregation function is responsible for combining the data from different nodes and for creating the aggregates. There are several taxonomies of aggregation functions. The first one divides the aggregation



functions into lossy and lossless [28]. Lossy functions assume that the original values from the aggregates cannot be recovered, and they also impose a certain level of imprecision. On the other hand, the lossless aggregation functions keep the possibility of retrieving the original values from the aggregates. Another taxonomy splits the functions into duplicate sensitive and duplicate insensitive [27]. This refers to the situation when an intermediate node receives multiple copies of the same data. In the duplicate sensitive function the reception of multiple instances of the same data will affect the value of aggregate whilst in the duplicate insensitive it will not. As an example, an aggregation function like *minimum* is duplicate insensitive whilst aggregation function of *average* is duplicate sensitive. Finally, apart from network architecture and aggregation function, data representation is also important because it impacts the storage capabilities of the nodes. Thus, it needs to optimally specify how the data is stored in order to enable efficient operation of the nodes. All these parameters of data aggregation should be chosen according to the nature and use of the specific application and should all be considered.

### 3.3 Data aggregation in VANETs

The goal of data aggregation is to increase communication efficiency and provide the nodes with a certain level of awareness about the observation together with its spatial and temporal context, beyond the current location. Every data aggregation process is designed around the following three separate processes [29]:

- **Data gathering-** defines the way of obtaining the data in the network either by the nodes on its own, via sensors, or by receiving it from another node.
- **Data processing-** defines the process of storing the gathered data and

extracting the knowledge from it for some decision making process, for example in traffic.

- **Data dissemination-** defines the process of sharing the gathered information and the knowledge of the node with other nodes in the network.

The communication efficiency can be enhanced by improving one or more of the three processes. In the Section 3.3 important features of data aggregation design in VANETs are introduced, which directly influence the three aforementioned processes. These features are formally formulated as a set of eight “challenges”, later used in comparative analysis of existing works. The “challenges” are aspects that need to be considered in data aggregation design.

One of such features is localisation and the importance of location information to the nodes. Moreover, location awareness is one of mandatory features of VANETs in respect to possible applications. The location information is not critical in WSNs, mostly because of its applications. For example, in WSNs the sensors are typically spread into a set of locations known to the user of the application, for example earthquake monitoring station. Knowing the actual position by the nodes is not necessary both for the applications and the data aggregation in WSNs. As described above, most aggregation schemes for WSNs are based on a certain network structure like a cluster, a tree or chain, which might be difficult or even impossible to build and maintain in VANETs. This is due to the node’s mobility, especially in urban areas where it is very unpredictable. Unlike traditional MANETs or WSNs, the nodes in VANETs are vehicles like cars, buses or cycles, which are operated by people in real-time. Therefore, the technology of VANETs is used as a platform to provide some real-time information to the drivers in order to improve their experience in terms of either safety or efficiency of driving. That is the reason why the existence of location information in VANETs is mandatory. The level of accuracy or precision of the location

information, however, depends on the type of application and its requirements. Some safety applications like collision avoidance require very precise location of the vehicles in order to warn surrounding vehicles of their presence and to prevent collision. On the other hand, vehicles do not require precise information of traffic congestion, but rather approximate information in terms of absolute or relative location.

We first briefly introduce localisation methodologies and systems used in VANETs and discuss their features, outlining their drawbacks and some solutions used to overcome them. It is assumed that in the future, vehicle will use multiple systems for localisation purposes that when used together provide accurate location information.

The main source of location information available to the vehicles in VANETs comes from on-board receivers for global positioning systems like GPS, Glonass or Galileo [35]. These systems are comprised of multiple satellites. In the case of GPS there are 24 satellites positioned above the Earth at the height of 20,000 km. The vast majority of research in VANETs has been carried out with the assumption that every vehicle in VANETs has these systems on-board. Such systems provide coordinates of the vehicle's current location. The coordinates are later mapped into the real digital map in case the vehicle has it on-board, or into some navigation system. Therefore the vehicle is always aware of its location and has the map of the entire surroundings which can be used to map information it receives from other vehicles. However, GPS and other positioning systems do have their drawbacks. Their reliability is not always guaranteed, especially in urban environments. Their outdoor precision might be compromised in urban environments, varying from 5 to 30 meters [35]. Finally, these systems are often not available indoors or underground, thus making it difficult to determine the location when vehicles are underground, for example in tunnels or parking areas. However, even though that existence of GPS device within the car is widely

assumed, some authors are concerned about this assumption [36]. Even though the drivers smartphones have a GPS embedded, it is still not the part of VANET onboard unit and therefore cannot be used.

The technique often used with GPS localisation is Map Matching [37], which stores location information about an area, for example a city, within the vehicle. It is used to reduce the errors of GPS by limiting the possibilities of vehicle's current position which can be only in the street areas. Additionally, Map Matching is also used to create the vehicle's estimated trajectory by observing several positions of the observed vehicle over regular time periods. Dead Reckoning [38] is a localisation technique often used with GPS in order to compensate its outage. It uses the vehicle's last known location obtained, by the GPS together with other mobility parameters such as direction, speed, acceleration, time or traversed distance. Because it accumulates errors quickly it is not recommended for use in long time periods of GPS unavailability. Another type of localisation that can be used in VANETs is cellular localisation [39], which is based on infrastructure for mobile communications. Here, the base stations that the receiver is connected to are tracked and handovers between different cells are followed. There are several methodologies used in cellular localisation and some include Received Signal Strength Indicator (RSSI) analysis, Time of Arrival (ToA) analysis, Time Difference of Arrival (TDoA) and Angle of Arrival (AoA) analysis [40]. These techniques are less precise than the use of GPS but they can be used in addition to the GPS to improve its accuracy. Image or video processing is another technique used for localisation, especially in robot systems [41]. Deployed on vehicles, it shows the environment in front and behind, for example the position of traffic lanes or signs by the road. Finally, for the localisation purposes relative localisation can be used as in WSNs. This type of localisation constructs local relative position maps by estimating the distances between neighbouring nodes and exchanging them in multi-hop communication. Previously mentioned localisation

techniques can be combined to obtain reliable and accurate location information. This can be done by using some of the well-known data fusion techniques such as the Kalman Filter or the Particle Filter. This is out of the scope of this research, but some examples can be found in [42].

When the vehicle is able to obtain its coordinates or its position, it can assign location context to any observation from its on-board sensors and send it to other vehicles with location context attached. The vehicles that receive this information are aware of the value of some observation at the specified location, according to location context of the received message. This is the main paradigm of VANETs - the nodes communicate in order to become aware of an area and vehicles that are beyond their current location or line of sight. The type of data sent within the network depends on the application type, but generally speaking can be anything from a number of parking spaces available, to the level of traffic congestion or current weather information.

It is important to understand how the location information can be used in data aggregation in VANETs, and its impact on the communication efficiency. Let us assume that the vehicles in the high density network periodically send the value of some measurement from their on-board sensor, for example the traffic congestion level. In addition to the congestion level, every vehicle also sends its GPS coordinates. When neighbouring vehicles receive such messages they would know the GPS coordinates of certain levels of congestion. Communicating this way about the detected level of congestion is not efficient because all of the vehicles from the same region have probably measured approximately the same level of congestion and there is no need for every vehicle to report it. Another problem is that vehicles would have to keep track of all the unique pairs of GPS coordinates received, which can increase vehicle's memory consumption. Additionally, the well-known storm problem might appear because many vehicles contend for the medium, which may lead to collisions and packet drops. Thus, avoid this

situation, data aggregation is used.

The question for the data aggregation mechanism is how to aggregate this big volume of data and still enable the vehicles to be aware of the level of congestion in surrounding areas. The answer to this question comes down to the right choice of three critical parameters: aggregation structure, aggregation function and dissemination mechanism.

The first parameter is the choice of the aggregation structure. How to spatially group the vehicles to accurately approximate the level of congestion in a certain area? We define the *aggregation structure*  $s$  as a tuple consisted of size, identification and location:

$$s = (size, identification, location) \quad (3.1)$$

Figure 3.4 shows the section of London urban area showing three groups of vehicles, which we refer to as yellow, green and blue. We assume that vehicles broadcast the levels of congestion, and their observations are shown in the coloured circles, which are sent to other vehicles. The vehicles are grouped in three different aggregation structures. In the yellow group, the structure is a city block. The problem of choosing the aggregation structure this large is its imprecision. This is because the block might contain several streets or parts of the streets, which can have different congestion level as in Figure 3.4. In yellow case in one of the streets, six vehicles have congestion values in range between 12.6 and 14.3. In second street in the same city block, there is one vehicle with congestion value of 2.3. Therefore, aggregating the congestion values of all the streets into one value would be misleading. Additionally, choosing the large aggregation area reduces the knowledge and awareness of the situation that is provided to the driver. Another example might be grouping per long street segments, as in green group, or per street segment containing lanes of two directions, as in blue

group of vehicles in Figure 3.4. Again, the aggregation as in green group seems imprecise because of the large size of the area, since in its parts might be different traffic conditions. In blue example of aggregation per street segment the issue is the vehicles are in opposite directions, thus such aggregation would also be misleading. Other than providing accurate information about an area, the aggregation structure also impacts the storing of such information in vehicle's database. Having in mind the size of the cities, the size of the aggregation area should be optimally chosen to enable efficient and simple database maintenance. For example, let's assume the streets are segmented into areas of 100 m in length and every area has its own unique identification. The number of slots in the database with unique identification for each slot would be enormously high in the case of large cities.

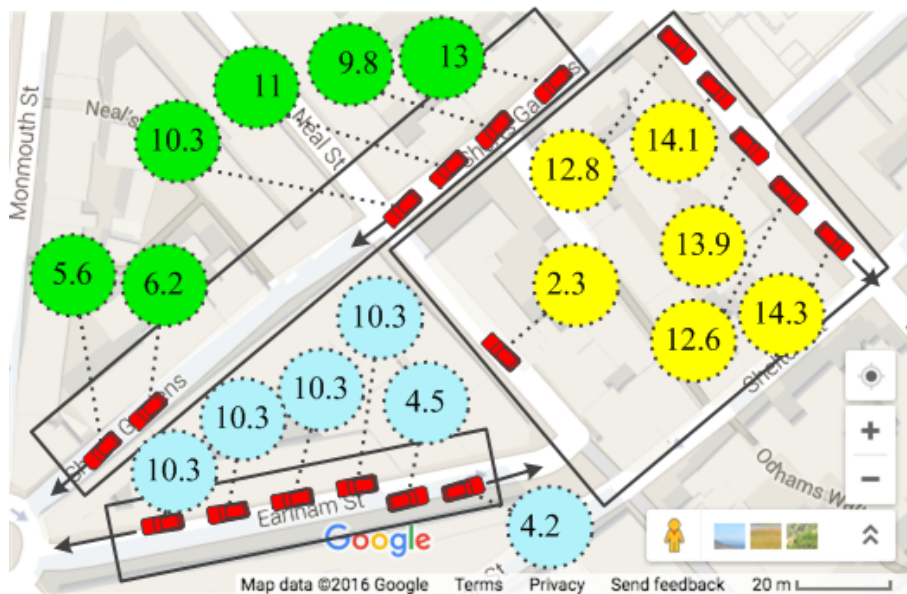

Figure 3.4: Urban area with different aggregation structures [43].

A good data aggregation mechanism should be able to adaptively determine the aggregation structure based on the values of observations measured and received. Additionally, this structure should be determined so it provides sufficient details to the driver about the level of observation in its neighbourhood. The structuring of the space should not impose a complex processing required

to maintain and store the data about a certain area. Finally, the data aggregation should ideally be done by the vehicle on the move without any predefined structure and with efficient database indexing [44], [45]. Formally, we summarise this into the Challenge 1 that data aggregation mechanism for VANETs needs to satisfy.

***Challenge 1: Optimal structuring of the spatial environment into aggregation structures that provide a satisfactory level of details about certain observation and at the same time provides efficient data storage and maintenance within the node. The segmentation of the road should be flexible.***

Another important parameter for the performance of the data aggregation mechanism that should be chosen carefully is the aggregation function that is being used, which specifies how the data is being aggregated [15]. We define the *aggregation function*  $a$  that takes generic observations as input and provides aggregate as output:

$$o_1(location_1), o_2(location_2), \dots, o_n(location_n), \xrightarrow{a} A_g(agg.structure) \quad (3.2)$$

Choosing the appropriate aggregation function is critical in order to determine the observed value. There are numerous aggregation functions from the very basic, e.g. *minimum* or *maximum* to the more complex aggregation functions like various estimation techniques. The aggregation function summarises all the values from the same aggregation area and provides the overall picture about the level of observation such as congestion for example. This choice depends on the purpose and the type of the application and should be chosen to be as realistic as possible. As mentioned earlier, the aggregation function can be lossy or lossless. In the lossy case, for example average, aggregate might include multiple information from same node which is double counted. On the other hand, the lossless



case might choose the minimum value. Additionally, it is extremely important to optimally select aggregation period as well. In case this period is too wide/long (for example one minute), then the aggregate might consist of older and younger observations. Some observations might have been received at the start of the aggregation period whilst the other might be received at the end, meaning that aggregation scheme should consider this as well. Figure 3.5 shows an example of two aggregation periods, short and long. In the short period three very similar congestion values are combined, whilst the long time period combines the values with large deviations. Here we formally define Challenge 2 to be used in the evaluation of existing works.

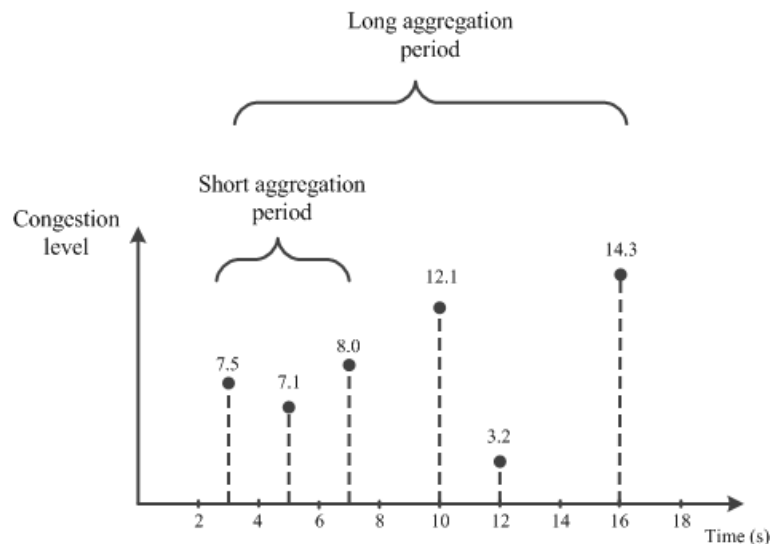

Figure 3.5: Data aggregation with short and long periods.

**Challenge 2:** The choice of the aggregation function, which combines generic observations both self-obtained and received from the other nodes in the network, needs to provide realistic representation of the current state of the observed value within the aggregation area.

The dissemination of the messages within the data aggregation is another important feature that directly impacts network load and scalability. The messages enable the vehicles to be aware of the observed values in their neighbour-

hood. Additionally, it is important to specify if and how the aggregates are disseminated, for example, if they are disseminated the same way as the generic observations, or differently. To do this, understanding of specifics of applications is necessary. Challenge 3 specifies the structure of the message in the dissemination concept. Finally, the aggregate structure should allow their merging and comparison with generic observations to enable better decision-making process within the network.

***Challenge 3:*** This schedule defines the structure of all types of messages used in the data aggregation mechanism and specifies which one of those is disseminated in the network. The message should be structured to propagate sufficient amount of data and create satisfactory level of awareness at the receiving nodes. Finally, aggregates comparing and fusing with generic observations should be possible.

Once the message structure is defined, the next challenge is to determine their dissemination process. The VANET applications can generally be categorised into two groups: safety and non-safety applications. However, this categorisation does not entirely show the nature of applications from the communications point of view. More appropriate categorisation to use in this case divides the VANET applications in event-driven and periodic. The event-driven applications are based on the dissemination of messages when some event occurs, for example an accident on the road. Then the vehicle that detects the accident sends urgent messages about it to other vehicles and the message dissemination in this type of applications is urgent in order to spread the information about the accident as quickly as possible. The way of dissemination in event-driven applications is flooding because all the vehicles that receive the urgent message will rebroadcast the same message. Unlike event-driven applications, the periodic applications do not require urgent message dissemination. However, they do require regular updates about some traffic phenomenon which are most commonly

delivered through single-hop periodic broadcasting. In this type of broadcasting the nodes process the received messages and send updates. The periodicity of both single-hop and multi-hop broadcasting in VANET applications is not standardised, but some research papers suggest that it could be as frequent as 100ms [15]. Also, we emphasize that both single hop and multi hop broadcasting are based on the same communication paradigm, but multi hop broadcasting messages have higher frequency and limited lifetime period. After that period, the messages become outdated and should be discarded. The main problem regarding the dissemination in VANETs is the potential broadcast storm which might cause delay, dropped packets and reduce scalability [46]. From the data aggregation perspective, the number of sent messages should be kept at the minimum in order to achieve communication efficiency, but not at the cost of accuracy of the disseminated data nor the delay. Challenge 4 defines the concept of data dissemination.

***Challenge 4: Dissemination algorithm needs to spread the data within the network with minimal broadcast activity without compromising the accuracy of the disseminated data.***

Aside from the challenges in achieving the communication efficiency, there are also some feasibility-related practical challenges, which also need to be taken into account when designing VANET data aggregation schemes. These are often not considered or are neglected in the design process of aggregation schemes. One such feature is consideration of the penetration rate. The penetration rate describes the portion of the total number of vehicles on the street that is capable of participating in VANETs. The penetration rate shows how many vehicles are equipped with on-board units (OBU) which enables the vehicles to communicate and use the VANETs applications. Most of the existing schemes [44], [45] and [47]-[55], as will be later shown, assume that all vehicles in the network are participating in VANET communication. As this will not happen instantly in

reality, the data aggregation mechanism should be able to operate even when the penetration rate is lower than 100%. Alternatively, this problem might be defined from network density perspective. The data aggregation mechanism needs to work both in very dense and sparse networks, without compromising the accuracy. Challenge 5 describes this:

***Challenge 5: Data aggregation should not be dependent on 100% adoption of VANET technology, thus should be able to operate even when not all the nodes in the network are VANET-enabled. Moreover, it needs to operate well both in dense and sparse networks.***

The design of the data aggregation mechanism should also enable that as many vehicles as possible are capable of using the scheme without any significant adjustments in terms of the available on-board systems. This concern comes from the pre-assumption that all vehicles have advanced on-board systems like satellite navigation and digital maps tailored to the aggregation scheme requirements. For example, if aggregation is performed on fixed size road segments with unique identification, then every vehicle should have all the possible identifiers of road segments within its database. Even the most common assumption that every vehicle possess GPS is regarded too optimistic by some authors [36]. The protocols for VANETs should therefore use some kind of basic and easily obtainable information to provide the drivers with local and real-time information about the traffic in their neighbourhood. Challenge 6 summarises aforementioned concerns.

***Challenge 6: Data aggregation should be able to operate within VANET that consists of as many vehicles as possible. To achieve this, data aggregation should not be based on advanced technology, which might not be available in the majority of the vehicles.***

Another challenge that data aggregation should be able to overcome is related to the specific VANETs application scenario. Applications in VANETs

research are mostly divided into urban and highway scenario. However, a single aggregation mechanism should be able to cope with both of these scenarios and other intermediate such as suburban or rural. This is formally stated in Challenge 7:

***Challenge 7: Data aggregation’s design should not be scenario-specific and should be able to operate in multiple scenarios.***

A well-recognised problem of existing aggregation schemes is the application-specific design [15]. Frequently, it is not possible to deploy the data aggregation scheme in more than one type of application at the same time. Very common approach in the literature is that data aggregation is developed for a specific application purposes, like for example traffic congestion management [47]-[49]. Therefore, there is a need for more generic data aggregation solution which can be used for more applications. This is stated as a Challenge 8.

***Challenge 8: Data aggregation mechanism for VANETs should not be dependent upon the type of application used, but should be generic to support different applications. Ideally, aggregation scheme should support the use of simultaneous and multiple applications with different priorities.***

There are many data aggregation mechanisms designed for WSNs and this has been widely researched area [27]-[29]. On the other hand, data aggregation in VANETs did not receive that much research attention, and the number of schemes designed specifically for VANETs is fairly limited [44], [45] and [47]-[55]. These works are presented below in separate sub-sections. Chapter 3 is concluded with their comparative analysis and statement of the problems of existing data aggregation schemes for VANETs. Additionally, each work will be analysed from the perspective of the eight presented challenges.

### 3.3.1 SOTIS

SOTIS [47] is one of the very first contributions towards distributed information dissemination in VANETs. It was designed to enable the vehicles to be aware of the traffic situation on the road. It supports both event driven and periodic applications, traffic congestion management and emergency messages.

The analysis of this scheme based on set of challenges is as follows:

- **Challenge 1 (aggregation structure):** The road segment size depends on the distance from the transmitting vehicle. In the simulation setup the street segment size is 500m and the amount of information stored in the database refers to the radius of 50 km around the vehicle. Maintaining such a database is complex, considering how many 500m street segments can fit into the 50km radius.
- **Challenge 2 (aggregation function):** The aggregation function used for the calculation of the traffic state of the vehicle's current road segment is averaging, whilst for the other road segment only most recent information is used.
- **Challenge 3 (message structure):** The vehicles in SOTIS periodically send *Periodic Reports* which contain information about the vehicle, including header and traffic information. The header has the fixed length fields with packet type identification, time of transmission, road identification and the speed. The traffic analysis is performed on per road basis and then transmitted. A regular SOTIS packet consists of a header and a payload identifying the road, start and end segment, and TTI values with time stamp for each segment. In addition to the periodic reports, the vehicles in SOTIS can send urgent *Emergency Reports* which have higher priority in MAC layer than *Periodic Reports*. These reports have the same header as

the periodic reports, but they do not contain traffic analysis. Instead, they have detailed information about the emergency.

- **Challenge 4 (*dissemination algorithm*)**: The dissemination process is based on three separate processes: Receive, Analyse and Send. The Send process is responsible for scheduling the time for the sending of SOTIS packets which is done periodically.
- **Challenge 5 (*penetration rate and density*)**: The system is designed to work in the case of extremely low penetration rates and according to the authors it should be able to operate even under 2% penetration rate. This is a good feature of SOTIS.
- **Challenge 6 (*advanced technology*)**: The vehicles in SOTIS are equipped with GPS receiver and digital map for the localisation purposes, meaning it relies on advanced localisation services built-in within the car.
- **Challenge 7 (*scenario type*)**: SOTIS is evaluated only in the highway scenario.
- **Challenge 8 (*generic design*)**: SOTIS is application-specific and does not support the operation of different applications, however it does support both periodic and event driven applications.

### 3.3.2 Traffic View

TrafficView [48], [49] is another well-known information dissemination framework for VANETs that was developed as a part of the e-Road project. TrafficView represents one of the early works in the VANETs area. It has not been designed solely as a data aggregation mechanism, but rather as the entire framework for communications with some hardware specifications included. One of its most important parts is the data aggregation mechanism, which is often being referenced. Unlike

most aggregation schemes which are space-centric, the TrafficView is a vehicle-centric scheme. In space-centric mechanisms the aggregated data refers to certain space, area or location, whilst in node-centric case like TrafficView the aggregated data refers to the neighbouring nodes in the network.

Vehicles send records that include their identification (ID), the current estimated position (POS) and speed (SPD). The scheme lacks aggregation of the reports per location segment and makes the vehicles aware about other vehicles in the network. Such approach is not conventional for VANETs, in a way that drivers are usually interested about location and not other traffic participants. The aggregation module performs data aggregation mechanisms in order to choose the data that will be put in the outgoing messages.

The analysis of this scheme based on a set of challenges is as follows:

- **Challenge 1 (aggregation structure):** The aggregation structure used in TrafficView is the set of vehicles. Each vehicle stores the records about other vehicles. However, the location context is considered within aggregation function below.
- **Challenge 2 (aggregation function):** The authors proposed two aggregation mechanisms for TrafficView: the ratio-based and the cost-based. In the ratio-based algorithm the road in front of the vehicle is divided into  $r_i$  regions, and for each of them the aggregation ratio  $a_i$  is assigned. This ratio is defined as the inverse of the number of vehicles that are aggregated in one record and each region gets the portion  $p_i$  of the free space in the message where  $0 < p_i \leq 1$ . The main factor when assigning the aggregation ratios and region portions is the importance of the regions and the accuracy requirements for the regional information. The second aggregation algorithm is cost-based and it assigns a cost for aggregation of each pair of records and always selects the pair with the minimum cost.



- **Challenge 3 (message structure):** The aggregates have similar format as single records with the exception of the IDs, and the aggregates look like:  $(\{ID_1, \dots, ID_n\}, POS_a, SPD_a, BT_a)$  where  $BT_a = \min\{BT_1, \dots, BT_n\}$ ,  $POS_a = \sum_{i=1}^n \frac{POS_i}{d_i}$  and  $SPD_a = \sum_{i=1}^n \frac{SPD_i}{d_i}$ ,  $d_i$  is the estimated distance between the current vehicle and the vehicle with  $ID_i$ .
- **Challenge 4 (dissemination algorithm):** Dissemination algorithm used is periodic broadcasting.
- **Challenge 5 (penetration rate and density):** The penetration rate of the technology is not discussed thus we assume that the mechanism works only under 100% penetration rate.
- **Challenge 6 (advanced technology):** Traffic View uses advanced localisation techniques including GPS and digital maps.
- **Challenge 7 (scenario type):** Traffic view is only tested in highway scenario.
- **Challenge 8 (generic design):** The design of the scheme is not generic since it is designed only for traffic congestion management applications.

### 3.3.3 Fuzzy Logic Based Structure Free Approach

Authors in [44], [45] proposed a structure-free aggregation concept to data aggregation based on fuzzy logic, that allows the vehicle to decide whether or not to aggregate the incoming messages based on a flexible and extensible set of application specific criteria. These criteria enable a dynamic fragmentation of the road, thus this approach does not require any predefined structures for the aggregation and since it is generic, it can be used for any type of application. The messages are being aggregated based solely on their content, rather on the predefined structures like street segments.

The analysis of this scheme based on a set of challenges is as follows:

- **Challenge 1 (aggregation structure):** The concept of this scheme is to perform the aggregation based on the content correlation of two messages rather than considering their spatial context. In the application independent part of two aggregates, the time and space domain, are defined as a smallest 2D rectangle that covers both  $A_1$ 's and  $A_2$ 's time-space area. This might result in a higher level of inaccuracy if location overlap of two generic observations is minimal. Additionally, processing aggregates based on this concept might be complex and the level of awareness about spatial distribution of some traffic phenomenon is not structured. Vehicle becomes aware about random set of locations, which can lead to inefficient decision making in traffic situations.
- **Challenge 2 (aggregation function):** The authors considered example of the vehicles' speed and their difference in order to reach decision whether two aggregates should be merged. The two aggregates which are being aggregated are  $A_1 = ((a_1, s_1), (b_1, e_1), c_1, D_1)$  and  $A_2 = ((a_2, s_2), (b_2, e_2), c_2, D_2)$ . The resulting aggregate  $A_r = ((a_r, s_r), (b_r, e_r), c_r, D_r)$  defined according to the following aggregation function:

$$\mu_r = \frac{\mu_1 c_1 + \mu_2 c_2}{c_1 + c_2}$$

$$\sigma_r = \sqrt{\frac{1}{c_1 + c_2} ((\sigma_1^2 + \mu_1^2) c_1 + ((\sigma_2^2 + \mu_2^2) c_2) - \mu_r^2)}$$

- **Challenge 3 (message structure):** The structure of the aggregate within the scheme is:  $A = (\vec{a}, \vec{b}, c, D)$ , where  $(\vec{a}, \vec{b}) = ((a, s), (b, e))$  refers to time and location. The minimum in space dimension is  $a$  and the maximum is  $b$ , whilst  $s$  is the minimum in time and  $e$  is the maximum in time. The number of information items that contributed to the aggregate is  $c$ .

- **Challenge 4 (dissemination algorithm):** The scheme uses relevance functions to choose which aggregates are most relevant for dissemination, however they are disseminated periodically.
- **Challenge 5 (penetration rate and density):** The penetration rate and network density are not considered within the scheme thus we'll assume the scheme is designed to work only in 100% VANET penetrated network.
- **Challenge 6 (advanced technology):** The scheme does not need pre-defined location segments to operate however, the aggregates do contain location information obtained most probably by the GPS, since its not clearly stated.
- **Challenge 7 (scenario type):** The scheme is evaluated only in highway scenario.
- **Challenge 8 (generic design):** The design of the scheme is generic and can be used for various VANET applications.

### 3.3.4 Probabilistic Aggregation

The Probabilistic Aggregation [50], [51] algorithm is a hierarchical approach for aggregating the observations in VANETs. The main characteristic of this scheme is that its aggregates do not contain any specific values about a location (for example number of parking spaces in some area), but contain a probabilistic approximation instead. This approximation is based on modified Flajolet-Martin sketches used for data representations. The main advantage of this scheme is its insensitivity to duplicates, which is very important in cases when multiple aggregates about same area are available it is possible to combine them into one aggregate containing all the original information from both aggregates.

Since the scheme is duplicate insensitive, it allows creation of various sizes of sketches where one can be inside of another. The example would be one road segment represented by a small sketch and one bigger sketch for the whole neighbourhood containing the same road segment. The FM sketches are modified to soft-state sketches for the aggregation scheme in order to allow the removal of the old information. Larger aggregates are typically distributed at longer distances while smaller ones are distributed in the vicinity.

The analysis of this scheme based on a set of challenges is as follows:

- **Challenge 1 (aggregation structure):** The city area is divided into 256 segments which represent single locations and in each of them the stochastic process was simulated, which was measured by the vehicles and used as an observation. To achieve hierarchical aggregation 256 segments are also grouped into 64 groups of 4 areas, and these 64 areas are again grouped into 16 groups of 4 areas. Thus the hierarchy consists of single, medium and large-scale areas. However, there is no specified strategy for choosing which information will be sent in the messages but the authors used the example of sending the totally 27 aggregates, on all three levels for the segment/area the vehicle is currently in and eight neighbouring areas. The structures used here are city blocks which might be imprecise as discussed in the definition of this challenge.
- **Challenge 2 (aggregation function):** Upon the reception the sketch is merged with the local sketch using the bit-wise OR operation.
- **Challenge 3 (message structure):** In the first step of the scheme the vehicle assigns each road segment a sketch and when it passes through that segment  $r$  it adds the tuples  $(r, 1), \dots, (r, n)$  to the sketch by hashing them and adding the respective bits. These sketches are used both for generic observations and aggregates, but they do not allow comparing of

two aggregates directly. It does however allow incorporating of lower-level aggregates into higher-level aggregates.

- **Challenge 4 (dissemination algorithm):** The scheme uses periodic broadcasting for dissemination of the sketches.
- **Challenge 5 (penetration rate and density):** The scheme was tested with 20% VANET penetration rate.
- **Challenge 6 (advanced technology):** The use of the GPS within the scheme is not explicitly defined, however it is referred that vehicle can obtain the location information. Therefore we assume its done via GPS.
- **Challenge 7 (scenario type):** The scheme was evaluated in real city scenario.
- **Challenge 8 (generic design):** As stated by the authors, the sketches can be used to approximate sums of positive integers and with some generalisation the floating numbers as well, and thus it is applicable whenever the aggregated value can be expressed through sums (counts, sums, averages, variance and standard deviations, products). This means the mechanism is limited only for values that can be expressed through sums.

### 3.3.5 DA2RF

DA2RF [52] is an infrastructure free data aggregation mechanism that focuses on restricting the forwarders and thus reducing the network load. The mechanism is described on a very high level focusing only on the dissemination process. Since it is also improving communication efficiency by limiting the number of broadcasting nodes, we will later use it as a reference point in the evaluation of our mechanism. The vehicle within the scheme will be non-forwarder in case that the first neighbouring vehicle in front and behind it are forwarders. This

is determined via neighbour list which is filled in by the incoming messages and GPS coordinates within them.

The analysis of this scheme based on a set of challenges is as follows:

- **Challenge 1 (aggregation structure)**: There is no aggregation structure considered in this scheme since it only focuses on the restriction of forwarders.
- **Challenge 2 (aggregation function)**: There is no aggregation function used in this scheme.
- **Challenge 3 (message structure)**: Vehicles send beacons that only contain identification of the vehicle and its GPS.
- **Challenge 4 (dissemination algorithm)**: Dissemination in DA2RF is adaptive based on the position of the vehicle and its neighbours.
- **Challenge 5 (penetration rate and density)**: This was not considered in this scheme thus we assume it operates in 100% penetration rate.
- **Challenge 6 (advanced technology)**: The scheme uses GPS system and every vehicle sends its coordinates in the message.
- **Challenge 7 (scenario type)**: The mechanism was tested in real city scenario.
- **Challenge 8 (generic design)**: Even though it is not specified, we think that the scheme can be applied to any type of application.

### 3.3.6 CASCADE

CASCADE [53] is the aggregation scheme designed for highway applications based on cluster-based compression. The vehicles are equipped with GPS and the

scheme is designed for one-way highway scenarios, in which vehicles send Primary records containing their individual information. When Primary records are received, they are grouped into their corresponding clusters, based on their distance from the receiving vehicle and present Local View. The single vehicles within the clusters are presented by their Compact Data Record. This record is created using the compression based on differential coding, which means that CASCADE represents only the differences between the vehicle data and overall cluster data. The compact data record consists of the median speed of the vehicles in the cluster and the positions of the vehicles are described with XY coordinates representing the distance from the centre of the cluster. Then, upon completion of the compression vehicles periodically aggregate Local View into an Aggregated Record which is then broadcast to other vehicles.

The analysis of this scheme based on a set of challenges is as follows:

- **Challenge 1 (aggregation structure):** The received Primary Records of the vehicles ahead of the vehicle form the Local View. It is divided into clusters 126 m long and 16 m wide and it's consisted of 12 rows of clusters. In the clusters, the vehicles are grouped based on their difference from the centre of the cluster and the speed as a difference from the median speed of all the vehicles in the cluster.
- **Challenge 2 (aggregation function):** The aggregation function used is cluster based compression.
- **Challenge 3 (message structure):** *Primary Record* contains information about the vehicle and contains (*Timestamp, Location – latitude and longitude, speed, acceleration, heading, altitude*). The *Primary Record* is contained within the *Primary Frame* that according to our understanding represents one message and consists of the following fields: (*Type, sender's location, primary record, digital signature, certificate*). *Aggregated Records*

are made by aggregating the clusters from *Local View* and it contains the following information: *Cluster flag, cluster median speed, number of vehicles, compact data records*. Messages containing *Aggregated Records* consists of the following fields: *Type – primary or aggregated, Timestamp, Aggregating vehicle's X – coordinate, Aggregating vehicle's location, Aggregated cluster records, Digital signature, Certificate, Sender's location*.

- **Challenge 4 (dissemination algorithm):** There are two dissemination methods used in this scheme. Periodic broadcasting is used for dissemination of primary records and aggregated records. In both cases the receiving vehicles will use probabilistic-Inter-Vehicle Geocast (p-IVG) to rebroadcast the message further. Thus, such broadcast activity is high, and does not contribute towards communication efficiency and reduction of the network load.
- **Challenge 5 (penetration rate and density):** Density and penetration rate of the network were not discussed, thus we assume it is 100%.
- **Challenge 6 (advanced technology):** The authors assumed the vehicles are equipped with both GPS receiver and digital maps.
- **Challenge 7 (scenario type):** CASCADE is defined and evaluated for highway scenario only.
- **Challenge 8 (generic design):** As per authors the scheme is designed to support both safety (collision warning) and information (congestion notification) applications.

### 3.3.7 Catch-Up

Catch-Up [54], [55] is an aggregation scheme designed for VANETs highway scenario. It enables multiple aggregates to meet at the same node which is enabled



via adaptive broadcasting. Adaptation of broadcasting is achieved by inserting the delay before sending the messages in order to increase the probability that reports can be merged with reports ahead or behind. The delay adaptation is based on the local observations by the vehicle and the future reward model is designed to define the benefits of different delay control policies. Vehicles choose the optimal policy based on the decision trees. The road is divided into road sections and the time axis is divided into time frames. If two reports are originating from the same road section and from the same time frame, then they are called aggregatable reports.

Therefore, since the two aggregatable reports originate from the same event frame, the goal of this scheme is to generate a single overview report from Event Frame  $(p_1, p_2, t_1, t_2)$ . Once this is created it is disseminated to other vehicles. The focus of this scheme is on the routing-related aspect. The paper explains the decision making process of the vehicles in order to determine when to forward the message so it can reach the other report and can be merged.

The analysis of this scheme based on a set of challenges is as follows:

- **Challenge 1 (aggregation structure):** The road is divided into road sections and the length of the section in the evaluation of the scheme was set to 1km.
- **Challenge 2 (aggregation function):** The authors look at the aggregation process from two aspects, data-related and routing-related. For the data-related aspects, the authors suggest using one of the following merging functions: maximum, minimum, average or probabilistic aggregation.
- **Challenge 3 (message structure):** Each event is defined by an Event Frame tuple containing starting position  $p_1$  and ending position  $p_2$  of a road section together with starting and ending time of a time frame  $t_1$  and  $t_2$ :

$(p_1, p_2, t_1, t_2)$ .

- **Challenge 4 (dissemination algorithm):** The scheme uses adaptive broadcasting by inserting the delay before sending the messages. This is done to increase the probability that reports can be merged with reports ahead or behind. The amount of delay depends on the vehicle's observations and the future reward model is designed to define the benefits of different delay control policies. Vehicles choose the optimal policy based on the decision trees. It needs to be pointed out that this dissemination is designed for event-driven applications.
- **Challenge 5 (penetration rate and density):** Penetration rate and density of the network are not considered in this scheme, thus we assume it is 100%.
- **Challenge 6 (advanced technology):** Vehicles are equipped with GPS receiver and digital maps.
- **Challenge 7 (scenario type):** The Catch-Up scheme assumes only highway scenario.
- **Challenge 8 (generic design):** The design of the scheme is not totally generic, because it is not designed for periodic applications. It is generic for event driven applications.

## 3.4 Comparative analysis

So far we have introduced some of the typical issues and challenges of VANET's operation paradigm, the potential data aggregation solutions and outlined some of the challenges related to the design of such schemes. Additionally, the most relevant data aggregation schemes designed for use in VANETs were presented and

include: Fuzzy Logic approach, TrafficView, SOTIS, Probabilistic aggregation, CATCH-UP, CASCADE and DA2RF. Brief comparative overview of their main characteristics is presented in Table 3.1.

There are number of drawbacks of having fixed pre-defined structure-based data aggregation in VANETs. One of them is lack of flexibility, when the segments are too large it can lead to inaccurate aggregation, or when they are too small the aggregation is inefficient. Additionally, maintenance of database containing unique identifications of all street segments in an urban area is computationally expensive and complex. The scheme that is flexible in terms of aggregation structure is Fuzzy logic approach. It does, on the other hand, make spatial understanding complex, since all the aggregates are stored independently without any structuring of the database. The presented aggregation schemes use various aggregation functions. The choice of aggregation function directly impacts the existence of the old information in aggregates and its inability to be removed. For example if averaging is used, aggregate might contain old information depending on the aggregation window size. From presented schemes, the Probabilistic scheme addressed this issue. Thus data aggregation in VANETs should be providing real-time and new data. To make decision-making process within the scheme better, aggregates should also be able compare with generic observations. Moreover, the merging of aggregates and generic observations is important also. In terms of message size, understandably it is better to keep them as low as possible. Some of the schemes like Cascade and TrafficView send rather detailed reports which can result in large message size. Additionally, the maximum payload of WSMP data needs to be kept in mind, which is 4096 bytes. Other than message size, the major concern among existing schemes is the use of periodic broadcasting, due to its negative effects on network load. CASCADE and Catch-up use adaptive broadcasting, but only for event-driven applications. In extreme cases like CASCADE, apart from sending their own messages, vehicles also rebroadcast

Table 3.1: Comparison of data aggregation mechanisms.

	SOTIS	TrafficView	Fuzzy Logic	Probability	DA2RF	CASCADE	CATCH-UP
<b>Challenge 1: Aggregation structure</b>	500 m	None	Varying size	256 city blocks	No structure	126 m x 16 m	1 km
<b>Challenge 2: Aggregation function</b>	Average	Cost-based, Ratio-based	Specific	Bit-wise OR	No function	Cluster-based compression	Max, min, average, probabilistic
<b>Challenge 3: Message structure</b>	Road id, start segment	Ids of neighbours, average distance	Min/max intervals of time and space	Sketch for each road segment	Vehicle identification and coordinates	Time, location, mobility parameters	Start-end pairs of time and position
<b>Challenge 4: Dissemination algorithm</b>	Periodic broadcast	Periodic broadcast	Periodic broadcast	Periodic broadcast	Adaptive broadcast	Periodic, adaptive broadcast	Adaptive broadcast
<b>Challenge 5: Penetration rate and density</b>	2%-100%	100%	100%	20%	100%	100%	100%
<b>Challenge 6: Advanced technology</b>	GPS, digital maps	GPS, digital maps	GPS, digital maps	GPS, digital maps	GPS, digital maps	GPS, digital maps	GPS, digital maps
<b>Challenge 7: Scenario type</b>	Highway	Highway	Highway	Urban	Urban	Highway	Highway
<b>Challenge 8: Generic design</b>	App-specific, periodic and event driven	App-specific	Generic	Only for values expressed through sums	Generic	App-specific, periodic and event driven	Generic for event-driven applications

the messages received from other vehicles, which can lead to further congesting the medium. DA2RF does provide forwarder restriction capability, but most of the other challenges within the scheme were not addressed. Thus we believe that data aggregation needs to enable the vehicle to adapt broadcasting activities. This can be done by leveraging the knowledge the vehicle possesses about the traffic state, and concepts like adaptive broadcasting [56]-[58] and passive clustering [59]-[61] integrated within the mechanism together.

Most of the schemes, except SOTIS and Probabilistic approach did not consider varying the penetration rate or node density. This is serious concern, because the data aggregation scheme needs to be able to operate in various traffic scenarios which corresponds to the traffic in reality. Analysis showed that all the schemes rely on precise location information obtained from GPS to provide the drivers with location awareness, thus the scheme which will overcome this limiting assumption is needed. Additionally, most of the applications are scenario-specific and have been tested in highway scenario.

It can be noted that the most schemes are not designed generically to be used for more than one application, nor to support both periodic and event driven applications. Some of them like SOTIS do support both periodic and event-driven applications, but it is not generic approach since it is application-specific. Some of them are generic for certain type of applications, like Catch Up for event driven applications. In ideal case, the data aggregation for VANETs should enable simultaneous use of multiple applications. Such example might include traffic congestion management, the number of free parking spaces and collision avoidance as a periodic applications. At the same time the event-driven applications could be collision detection and road hazard detection.

The previous analysis of the related work shows that a clear need for a more universal data aggregation solution exists. Operational challenges are related to flexibility and efficiency of the structuring the roads and storing the information about them in the database. Additionally, the need for data aggregation mechanism able to work regardless of vehicle on-board systems, type or number of applications used and in various network densities still exists. Finally, all these challenges should be accompanied with the reduction of network load.

# Chapter 4

## Location Aware Data

### Aggregation for VANETs

In line with the aforementioned current research challenges of data aggregation mechanism design in VANETs, the development of this research follows a generic modelling approach presented in [62], [63]. Here, the authors proposed the *Architecture Model* which structures data aggregation into separate interconnected submodules each performing a specific function, as shown in Figure 4.1. These modules are: *Decision*, the *World Model*, *Dissemination* and *Fusion*.

The *Decision* module decides if and how the data obtained and received is being aggregated. The *World Model* presents vehicle's knowledge about the network and the environment, while the *Dissemination* module specifies if and how the dissemination is being done. The *Fusion* module specifies the way the information is being fused with other information.

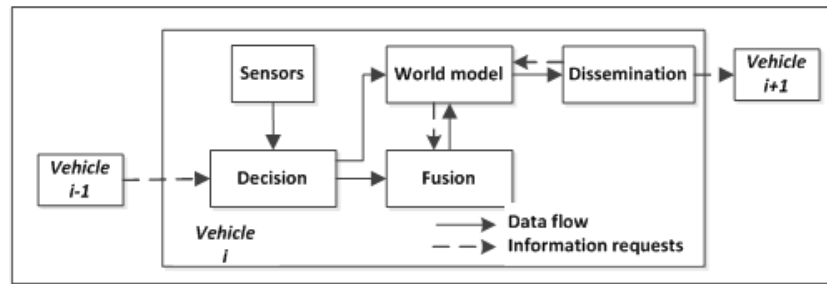

Figure 4.1: Generic data aggregation modelling for VANETs.

Due to the importance of location context in VANETs, as discussed in Chapter 3, we modified the generic modelling approach by introducing an additional *Localisation* module to more precisely specify the location context used within data aggregation schemes. The modified generic data aggregation approach is shown in Figure 4.2.

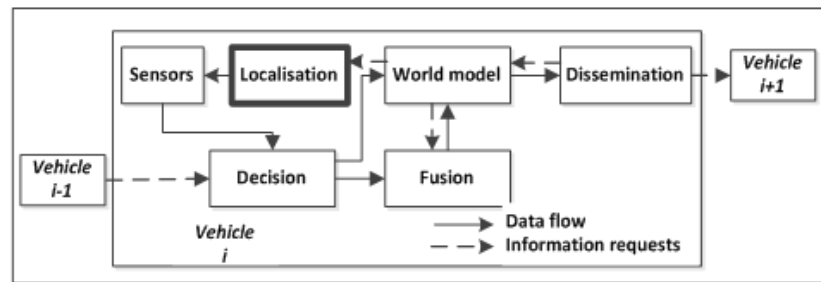

Figure 4.2: Modified generic modelling methodology for data aggregation.

The *Localisation* module is responsible for providing the location context that is used within the messages sent between the vehicles, and in database of the vehicle. Moreover, the *Localisation* is directly responsible for the architecture of vehicle's database and its maintenance.

The *Location Aware Data Aggregation* proposed in this thesis is presented in the upcoming sections following the structure from Figure 4.2. The proposed mechanism is referred to as the *LA* mechanism.

## 4.1 Decision

There are two ways the vehicle can obtain data in VANETs; one of the ways is to obtain the data on its own by taking measurements of a phenomenon while the other way is to receive it from other vehicles in the network. Both the measurement and received messages are collected through sensors as shown in Figure 4.2. The sensors can be various on-board equipment, from antennas to odometer, and can measure any type of information according to the application requirements, such as congestion level, average speed, parking space or weather information.

The *Decision* module of the aggregation scheme is responsible for reaching the decision if and when observations should be aggregated or stored in the database. Usually in aggregation schemes the decision will be yes, if two aggregates originate from the same area. Similarly, the *LA* mechanism merges the aggregates according to the location of origin. Upon reception of the message, the vehicle extracts the measurements and fuses them into the *World Model* according to other parameters contained within the message. This process is explained in Section 4.2, Section 4.3 and Section 4.4.

## 4.2 Localisation

The *Localisation* module of *LA* mechanism is based on *Location Awareness* technique, which provides flexible and dynamic segmentation of the road traversed by the vehicle, and a structure for data aggregation in the *LA* mechanism. Furthermore, it enables efficient spatiotemporal indexing of the vehicle's database.

The initial assumption is that the vehicle has access to basic information such as speed, traversed distance and direction, and does not have access to



any external positioning systems or third party information. The basic information can be obtained from the existing on-board systems like odometer or digital compass. The problem of GPS absence has been previously researched in other scientific areas and applications like underwater localisation for submarines or indoor localisation for robots and their mapping [64]. It is known as *Simultaneous Localisation and Mapping* (SLAM) [65], [66] and is often solved using graph theory. The nodes in the graph correspond to the poses of the robot at different points in time, and edges represent constraints between the poses. The concept of SLAM serves as a motivation ground to deliver feasible and accurate localisation service for data aggregation purposes in VANETs.

*LA* technique uses the direction parameter of the vehicle to characterise the vehicle's movement on the route and to enable the segmentation of the traversed roads. The direction of the vehicle corresponds to the direction of the street lane the vehicle is in, and their values are the same. Let  $\theta$  be the angle representing the current movement direction of the vehicle and let the driver or vehicle be able to recognise the direction of the surrounding streets. We assume that direction can be always obtained and let it have values in the following range:

$$-\pi \leq \theta \leq \pi \tag{4.1}$$

Vehicles periodically measure the value of  $\theta$  in order to divide their route into street sections, using the change in  $\theta$  as an indicator of the street section change. According to the *LA* localisation technique, every time angle  $\theta$  changes, the new street section on the route will be detected by the vehicle, and thus the route  $S$  of the vehicle is defined as a sequence of consecutive street sections  $s_i$  and each of them characterized with direction  $\theta_i$ :

$$S = \sum_k s_k(\theta_k) \tag{4.2}$$

Theoretically, angle  $\theta$  should be constant per detected street section, but this would result in an infinite number of unique angles  $\theta$  and thus an infinite number of street sections on the route of the vehicle. To overcome this problem, we define a finite offset value  $\Delta\theta$  which defines the street section as unique as long as the following equation for two successive angle values  $\theta_1$  and  $\theta_2$  is fulfilled:

$$|\theta_2 - \theta_1| \leq \Delta\theta \text{ and } timer > T_C \quad (4.3)$$

Strictly speaking, vehicle would detect new street segments even when overpassing other vehicles or when steering into the streets. To avoid this problem, we introduce a *timer* which needs to be larger than  $T_C$  time period so the new street segment can be detected. The value of  $T_C$  needs to be chosen to be greater than the time needed for the vehicle's steering in the overpassing process, for example 5s or 10s. Based on (4.3), vehicle will detect a new street segment when the difference of angles is greater than  $\Delta\theta$  for the time period longer than  $T_C$ . Each time the street section is changed the counter of street sections,  $i$ , on the route is incremented. This way the algorithm enables the vehicles to approximate their routes with the finite number of street sections, as shown in Figure 4.3 and with pseudocode in Algorithm 4.1. In the line 2 of Algorithm 4.1 the variables *time*, *timer*, *location*, *buffer* and  $i$  are initialised. The variable *time* represents a real time in discrete time intervals. The function *get(CurrentDirection)* from line 3 retrieves the angle (direction) parameter of the vehicle and stores it into variable *location*. The vehicle checking the condition (4.3) is expressed in a pseudocode via two *if* conditions, starting from line 4. The variable *buffer* stores the direction of the vehicle from the previous timestamp. Once the difference between *location* and *buffer* becomes greater than  $\Delta\theta$ , the vehicle increments the *timer*. When the *timer* becomes larger than  $T_C$ , the new street segment is detected. Then the function *addSegment* adds the current street segment whose direction value is stored in a variable *location* to the route.

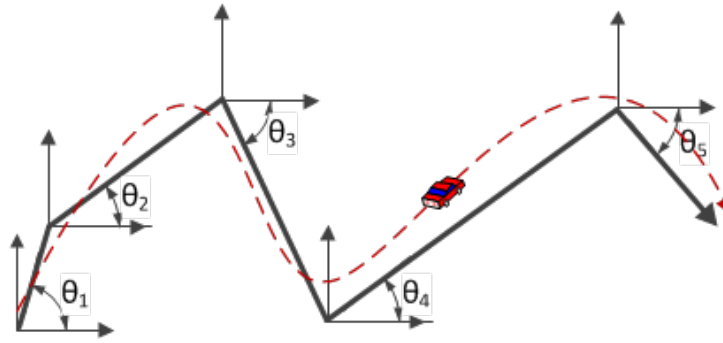

Figure 4.3: Route approximation process by consecutive street sections.

---

**Algorithm 4.1** The *LA* technique road segmentation

---

```

1: procedure LA ROAD SEGMENTATION
2:   initialise (time=0, timer=0, location=0, buffer=0, i=0)
3:   location=get(currentDirection)
4:   if (|location-buffer| > delta) then
5:     timer=timer+1
6:     if (timer >  $T_C$ ) then
7:       i=i+1
8:       route=addSegment(location)
9:       buffer=location
10:      timer=0
11:    end if
12:  else
13:    time=time+1
14:  end if
15: end procedure
    
```

---

Based on this method, the vehicles count the number of street sections they traversed as they move, and store the values of  $\theta$  and  $i$  for those segments. These parameters enable the vehicles to map the values of observation  $M$  to street sections they traversed, characterised by  $\theta$  and  $i$ . Direction based segmentation of the routes provides structure free aggregation, which does not require any pre-defined knowledge about the aggregation structures, such as unique IDs of all the fixed segments usually used in other data aggregation schemes.

Dynamic direction based segmentation of the vehicle route presents solid grounds for providing the location awareness and understanding of the surround-

ing environment to the vehicles. The vehicle can now use the values of  $\theta$  as an aggregation structure to aggregate the incoming observations originating from the same street segment. Since each segment is characterised by the angle  $\theta$  and the segment number  $i$ , it is easy to assign the measurement to the segment as well. Vehicles do the segmentation whilst moving on their route, periodically obtain measurements and assign them to the street segments. Therefore, an observation activity of the vehicle is structured per traversed street segment on which time variable measurements were obtained. For the vehicle with  $k$  street segments on its route, the route can be expressed as a set of tuples:

$$(\theta_1 i_1 M_1(t_1)), (\theta_2 i_2 M_2(t_2)), \dots, (\theta_k i_k M_k(t_T)) \quad (4.4)$$

However, the most important feature of VANETS is that the vehicles share their knowledge with others. *LA* technique enables this as well, by introducing two additional parameters: the knowledge depth  $K$  and the granularity  $g$ . They define the “knowledge size” that vehicles will have by using the *LA* data aggregation mechanism, which is later introduced. The knowledge size depends on the applications requirements and can be adjusted accordingly.  $K$  determines the size of the message that vehicle sends, which is shown in Figure 4.4. The message contains generic observations from last  $K$  street sections that vehicle traversed, in the following format:

$$|M(k), \theta(k), i(k)|, \text{ where } k = 1, \dots, K \quad (4.5)$$

$K$  provides the historical “depth” of the observed measurement  $M$  the receiving vehicle will obtain. When vehicle receives the message from another vehicle, it knows the values of observations of the sending vehicle from the previous  $K$  street sections. For example, in the case of  $K=3$ , vehicles in the network send the values of observation  $M$  for the last three street sections on their route.

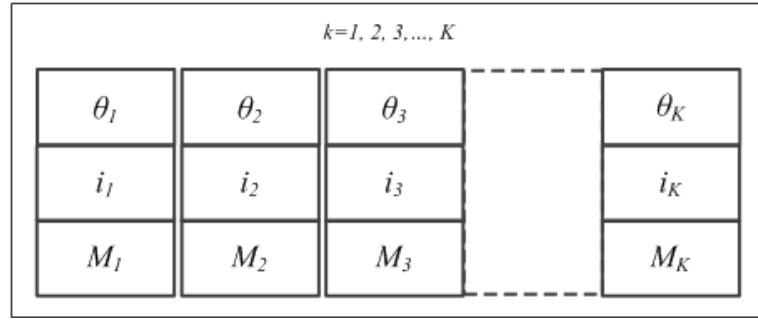

Figure 4.4: The structure of the message.

Clearly, storing information based on the real value of  $\theta_r$  would be inefficient because theoretically it can have infinite number of values. Because of that, the mapping function  $m$  is introduced which stores received information based on  $\theta_r$  and  $i$ , but in one of the finite number of predefined memory slots:

$$m : \theta_r \rightarrow \alpha_j \text{ where } \alpha_j = \frac{360^\circ}{g} \quad (4.6)$$

$$g \in Z \text{ and } \sum_j \alpha_j = 360^\circ \quad (4.7)$$

The memory slots  $\alpha_j$  represent bands of angles  $\theta_r$  is mapped into, and their number is determined by the granularity parameter  $g$  which shows the precision of the location awareness. In case  $g$  is large then the location information provided is more precise but at the cost of efficiency both in terms of the memory space, the processing power and time. We illustrate one practical example of mapping process for which we assume that  $g=20$ . According to 4.6 the size of the memory slots is  $18^\circ$ , and the vehicles divide  $360^\circ$  into 20 angle bands that are  $18^\circ$  degrees wide. The distribution of the angle bands is as follows:

$$\begin{aligned} \alpha &= 18^\circ \\ \alpha_i &= \{\alpha_1, \alpha_2, \alpha_3, \dots, \alpha_{18}, \alpha_{19}, \alpha_{20}\} = \\ &= \{0^\circ - 17^\circ, 18^\circ - 35^\circ, 36^\circ - 53^\circ, \dots, 342^\circ - 360^\circ\} \end{aligned} \quad (4.8)$$

If we assume that angle of incoming message is  $\theta_r=32^\circ$ , the result of the mapping function would be:

$$m(\theta = 32^\circ) \rightarrow \alpha_2 = 18^\circ - 35^\circ \quad (4.9)$$

As described in the example above, the result of mapping the incoming data based on the angle  $\theta_r$  would be in the second range of angles between  $18^\circ$  and  $36^\circ$ . By using the *mapping function*  $m$  the vehicle calculates the approximate value of direction of the street that incoming measurement originates from. In this case the approximate direction angle of the incoming measurements is somewhere between  $18^\circ$  and  $36^\circ$ . Now the driver or vehicle can recognise the street from the nearest vicinity whose direction lies in  $18^\circ$ -  $36^\circ$  range, and be aware of the level of observation on that street section.

On the other hand, parameter  $i$  describes the "historical" distance of the observation and measurement where the largest  $i$  refers to the current street section of the sending vehicle. By combining the distance and the direction obtained from incoming messages, the *LA* localisation technique creates spatiotemporal database indexing and provides the drivers with measurements in the streets sorted by their direction angle and by distance  $i$ . This way, the drivers know about the approximate traffic states in the streets in their nearest surroundings. When  $i=3$  the received measurement refers to the closest surrounding in the communication range, more specifically the street with  $\theta_r$  in the vehicle's vicinity. The measurements with  $i=2$  and  $i=1$  are one and two street sections further away, respectively, than the streets with  $i=3$ .

Therefore, street sections characterized with angle  $\theta$  are used as the structure for aggregation of observations in the memory. The algorithm does not need fixed predefined structure or any location information like coordinates or street names in order to aggregate the observations – it performs the aggrega-

tion independently while vehicle is on the move. The detailed architecture of the database in the vehicles is presented in the Section 4.3. By communicating the measurements attached with localisation parameters previously introduced and by receiving the aggregates from the local vehicles in their range, all the vehicles can create spatiotemporal awareness of the environment and the observed phenomenon.

### 4.3 World Model

The *World Model* represents the database in the vehicle and provides the spatiotemporal context to the stored information, thus enabling the driver or the application to use this information to adjust their traffic routes in real-time. It enables the driver or the vehicle to be aware of the intensity of the phenomenon in their surroundings. Not enough attention was dedicated to this topic in any of the existing works about data aggregation. Moreover, we could not find any recommendations about optimal or necessary size of the database that could enable some real traffic application. So far, the authors usually provide some general definition that specifies that vehicles have a database where they store observations obtained and received. Additionally, when the fixed segmentation with unique identification is used, the vehicles store information about entire city area. Apart from obvious processing complexity, there is a question of relevance of storing the data about the street that vehicle traversed long time ago.

The previously introduced granularity and knowledge depth parameters determine the database size for vehicles in the *LA* data aggregation scheme, defined as  $K \cdot g$ . The database architecture is explained on the example of two vehicles communicating, as shown in Figure 4.5. The two vehicles are shown, the red sending vehicle and the blue receiving vehicle together with their movement directions

measured as shown in Figure 4.5.

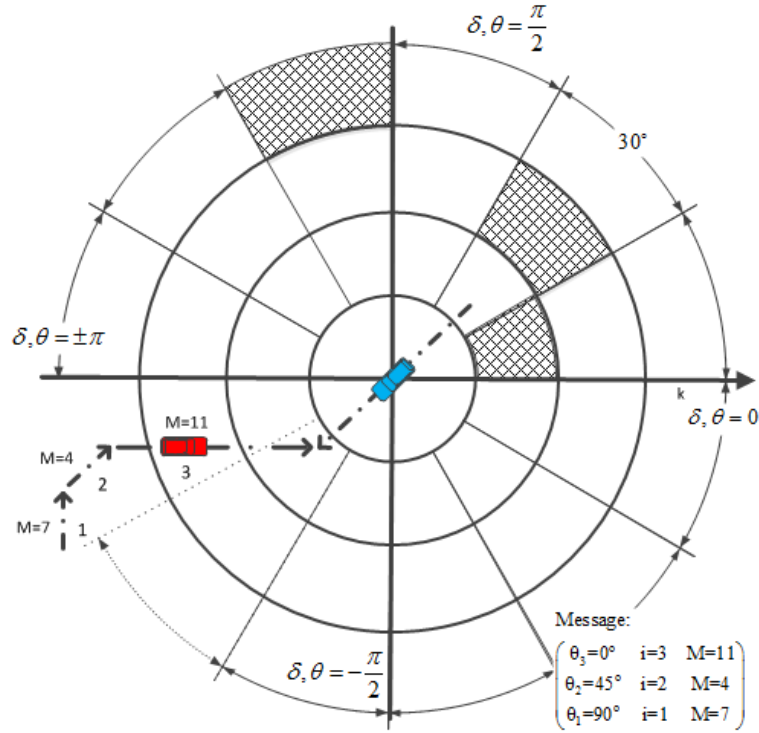

Figure 4.5: Example scenario of location awareness.

The red vehicle traversed street sections 1, 2 and 3, and it observed measurement values of 7, 4 and 11, on those street sections respectively. Using an assumption that knowledge depth  $K=3$ , the red vehicle sends the observations for the last three street sections traversed, which in this case are sections 1, 2 and 3. Therefore, the content of the message sent by the red vehicle will be as shown in Figure 4.5. Additionally, for this example, the granularity of the aggregation is set to  $g=12$ , meaning that the blue vehicle's spatial awareness is divided into 12 equal ranges of angles of  $30^\circ$ , as shown in Figure 4.5. Table 4.1 represents the part of an empty database that is being filled with the content of the received message from the example. Rows in the database refer to the street direction while columns refer to the distance of the received observation. According to those angular ranges, the memory slots are created in the database.

Based on the knowledge depth  $K$  and the granularity parameter  $g$  the vehicle will have the database dimensioned  $K \times g$ . Now vehicle stores the incoming



observations based on the combination of  $\theta_r$  and  $i$  and by using the mapping function  $m$ .

Table 4.1: Database structure.

Direction	Distance		
	$i=1$	$i=2$	$i=3$
$\theta_r=0^\circ: 29^\circ$			M=11
$\theta_r=30^\circ: 59^\circ$		M=4	
$\theta_r=90^\circ: 119^\circ$	M=7		

The example in Figure 4.5 shows the message containing observations from three street sections with angles  $\theta_r$  having values of  $\theta_{r3}=0^\circ$ ,  $\theta_{r2}=45^\circ$  and  $\theta_{r1}=90^\circ$ . These angles are mapped with  $m$  function and  $\theta_{r3}$ ,  $\theta_{r2}$ , and  $\theta_{r1}$  are mapped in the following angle bands from  $0^\circ$  to  $29^\circ$ ,  $30^\circ$  to  $59^\circ$  and  $90^\circ$  to  $119^\circ$  as shown in Figure 4.5 and Table 4.1. Therefore, by following the described procedure, the blue vehicle becomes aware that observation valued 11 will be in the first street section in the vicinity whose direction  $\theta_{r3}$  is between  $0^\circ$  and  $30^\circ$ . The observation valued 4 will be in next street section further away whose direction  $\theta_{r2}$  is between  $30^\circ$  and  $59^\circ$ . Finally, the observed value 7 is two street sections away with direction  $\theta_{r1}$  being between  $90^\circ$  and  $119^\circ$ . This way the blue vehicle becomes aware about the street sections that are in its immediate vicinity, but out of its communication range.

Finally, in order to work properly, the mechanism refreshes the *World Model* each time vehicle changes the street section. Vehicles will erase all the content of the database each time they enter a new street section on the road. The refreshing of the *World Model* keeps its content up to date because the old information about the observations is removed and provides the vehicle with the real-time and short-term knowledge about observations. Additionally, it should be pointed out that our approach enables direct comparison between measurements and aggregates, because they both refer to same street section at approximately the same time period.

## 4.4 Fusion

*Fusion* module specifies the aggregation function used for storing the incoming measurements by merging them with existing values in the database. One of the biggest challenges is to estimate the real value of the phenomenon when the number of incoming measurements is high. This is especially the case in VANETs where vehicles obtain the measurements both on their own and receive them from other vehicles. The issue here is that all these measurements arrive with relatively small inter-arrival times and the fusion technique is responsible for the creation of the estimates of the phenomenon. There are plenty of data fusion mechanisms and many of them have been widely used in wireless sensor networks. Extensive survey of such works can be found in [67]. One of the basic approaches is to overwrite the existing value in the database with the latest value. Drawback of such approach is that the values will look noisy and any application that is monitoring the incoming values would be challenged to follow the trend of the values. The other option might be to average several incoming measurement values which would require the vehicle to wait certain amount of time in order to receive enough measurements. Additionally, by averaging the values the precision and granularity of *LA* mechanism would be reduced, thus *LA* mechanism requires more advanced fusion mechanism.

Since *LA* mechanism is generic and can be used for dissemination of any type of VANET data, in the following Section 4.5.1 we first introduce the case study that presents an application used throughout this thesis. The case study specifies the data that vehicles communicate in the network on which the aggregation by the *LA* mechanism is performed. Upon introduction of the example application used in this thesis, the following Section 4.5.2 presents the data fusion mechanism used by the *LA* mechanism.

### 4.4.1 Case study

Prior to presenting the *Fusion* module of *LA* mechanism, it is necessary to understand what type of data vehicles exchange. As mentioned in Section 4.1, the proposed mechanism can be used for any VANET application. Still, one specific application on which the operation of *LA* mechanism will be introduced needs to be selected. Therefore, for the purpose of this thesis, we choose the traffic congestion management as an example application. In this application vehicles exchange measurements of traffic congestion which vehicles measure based on a protocol described in our previous works [68], [69]. There we presented the concept of quantification of traffic congestion based on the current values of a vehicle's speed and its trend over time. In this section we introduce the congestion quantification protocol and show its performance in order to make sure the protocol accurately differentiates different levels of traffic congestion which are later used in the communication between the vehicles.

Each vehicle derives the value of the congestion level independently by monitoring the trend of its current speed on its route over time. Every street segment on the route has congestion level value attached to it. In [68], [69] the street segments were of fixed size, determined by the GPS and the digital map. On the other hand, in this thesis we retain only the congestion quantification method whilst the localisation and road segmentation is performed according to the *LA* technique, as described in Section 4.1.

The vehicle derives the value of traffic congestion in the current street segment as follows:

$$\text{if } V_c > V_t \text{ and } T > 20s \text{ then } M = 1 + N, \quad (4.10)$$

$$\text{else } V_c \leq V_t \text{ and } T = \eta \cdot 5s, \eta = \{2, 3, \dots, 10\} \text{ then } M = \eta + N \quad (4.11)$$

Here  $V_c$  is the current speed of the vehicle, while  $V_t$  is the threshold for activating the congestion detection process.  $M$  is the level of traffic congestion and can have values between 1 and 10, while  $T$  is the time period which refers to time trend of  $M$  and  $N$  is additive white Gaussian noise (AWGN).

Thus, each vehicle takes measurements of its speed in real time, and as soon as the speed becomes lower than the  $V_t$  threshold, the congestion level starts incrementing. The level of congestion remains increasing as long as the current speed is lower than the threshold. Once the speed gets above the threshold, the congestion value is returned to 1. The number of congestion levels and the length of time intervals necessary for increasing the level of congestion were set to 10 and 20 seconds, respectively, as an example in [68], [69]. These can be calibrated to the real world traffic dynamics of some urban area. For example, a more realistic quantification can be achieved by setting the time interval for congestion levels 2 and 3 to the real time that vehicle normally stands on a traffic light. Another example might be assigning the value of congestion 10 to the cases that vehicle stands for more than 10 minutes. However, the optimisation of congestion quantification mechanism is out of the scope of this research. Thus, here we will use an example from [68], [69]. The detected values are then communicated to the other vehicles and the received values are merged into the database. In this thesis the database is the *World Model* and data fusion technique used by the *LA* mechanism is presented in the Section 4.4.2. An example case of vehicle's speed and its level of congestion is shown in Figure 4.6 where the threshold value was set to  $V_t = 6$  m/s. Similarly as with the number of congestion values and time intervals, the value  $V_t$  is an example taken from [68] and [69], since optimisation to the real urban traffic is not considered in this thesis. As can be seen in the Figure 4.6, as long as speed was under 6m/s, the congestion level kept increasing until the point when the speed exceeded 6m/s threshold. The scenario that the congestion quantification mechanism was evaluated in was urban. The area is

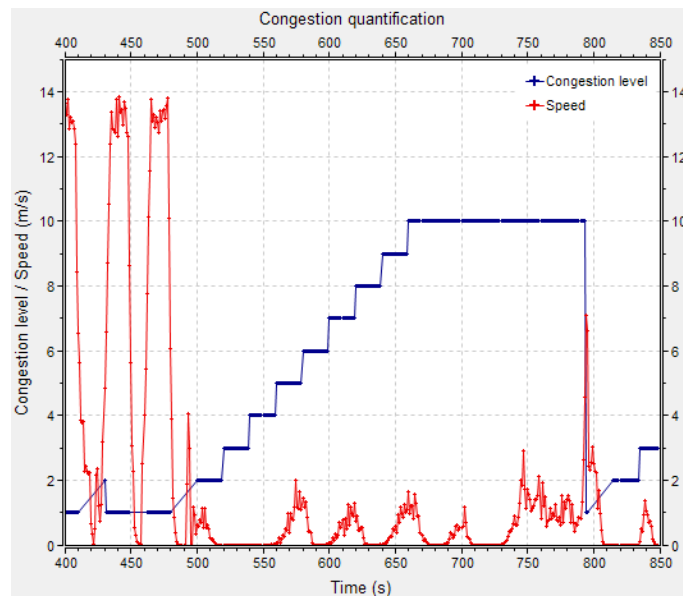

Figure 4.6: Congestion quantification process.

based on the Manhattan topology, sized of 1 km x 1 km, consisting of 250 m long street segments as shown in Figure 4.7. The figure shows both road network as well as the individual street segment.

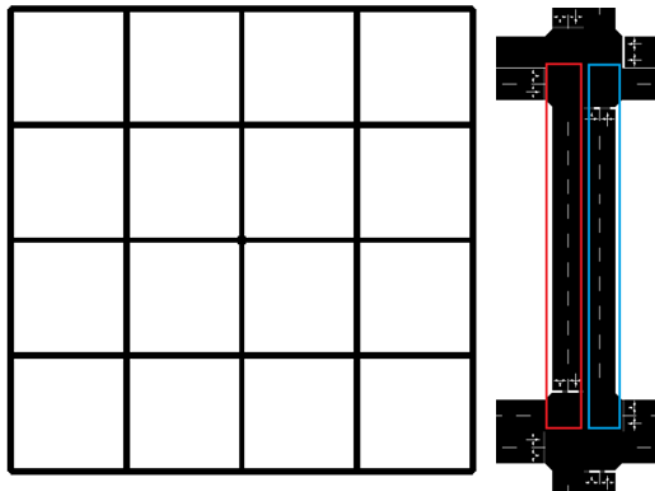

Figure 4.7: The road network consisting of 80 street sections, and two street sections of the road network one in each direction.

Showing the performance of congestion detection mechanism is important because vehicles using *LA* mechanism in this thesis are communicating the congestion information, thus the congestion detection mechanism needs to recognise various levels of congestion. Figure 4.8 shows the congestion values of a single ve-

hicle. These include the congestion level that vehicle detected on its own and the congestion value that vehicle received from other vehicles. Both of these values refer to the same street segments, the ones which vehicle traversed on its route. Figure 4.8 shows that vehicle received the congestion values related to the street segments prior to deriving them on its own. To show that the congestion level quantification results are in line with the real number of vehicles on the street we present Figure 4.9. This figure shows the real number of vehicles on six street segments that the example vehicle traversed. By comparing Figure 4.8 and Figure 4.9, we can see that the congestion level from Figure 4.8 follows the trend of real number of vehicles shown in Figure 4.9. This can be seen especially for Street 5 and Street 6, thus we conclude that the congestion quantification mechanism is capable of differentiating the congestion levels on streets. The results from Figure 4.6, Figure 4.8 and Figure 4.9 refer to one individual vehicle. Further, to show the global performance of congestion quantification mechanism, we present overall simulation results which correspond to the average values for all vehicles. Three street sections with different traffic densities are selected and presented in Figure 4.10 and Figure 4.11.

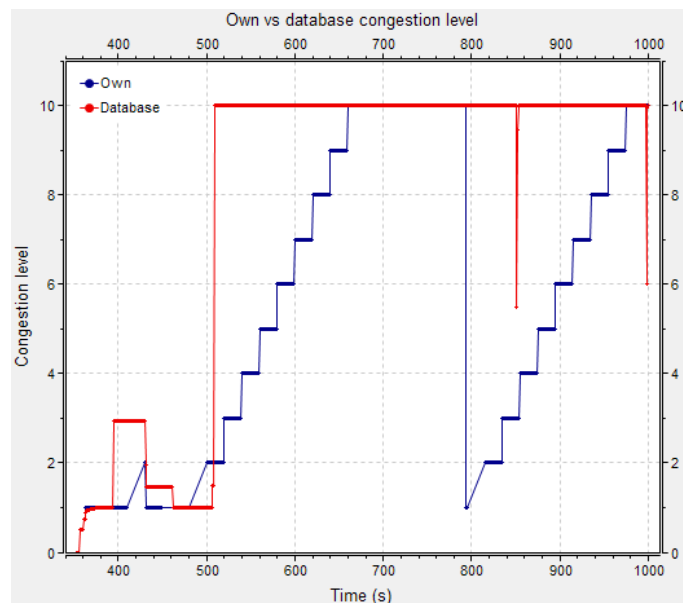

Figure 4.8: Detected values of congestion on the vehicle's route.

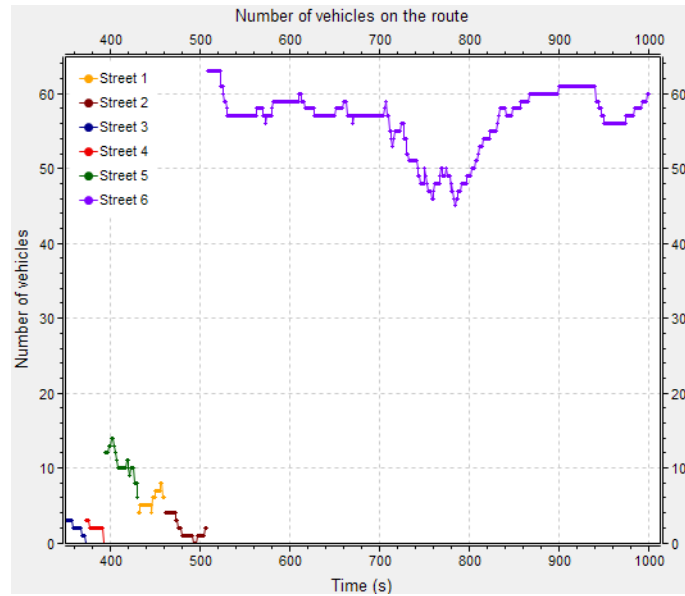

Figure 4.9: The real number of vehicles in the streets on the vehicle’s route.

In Figure 4.10 the average congestion values for streets with low, medium and high traffic densities are shown. Figure 4.11 presents the real number of vehicles on the same three street sections. Comparison of the two figures shows that results of the congestion level quantification follow the trend of real number of vehicles on the street.

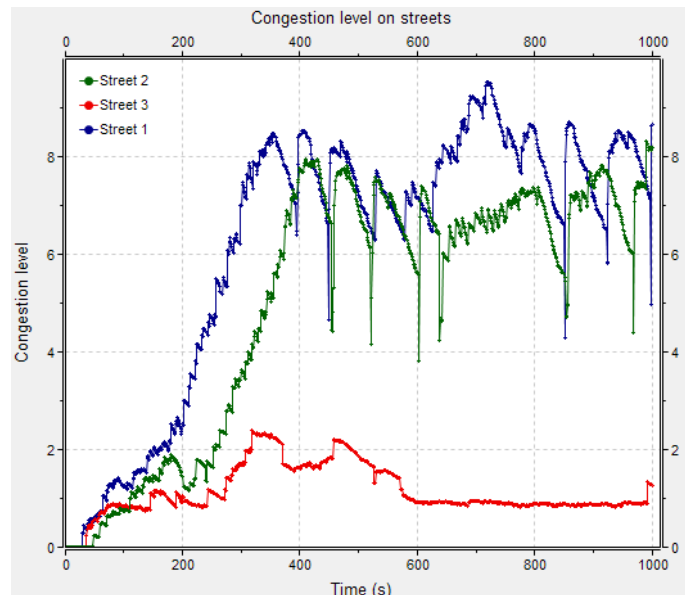

Figure 4.10: Average value of congestion levels on the route.

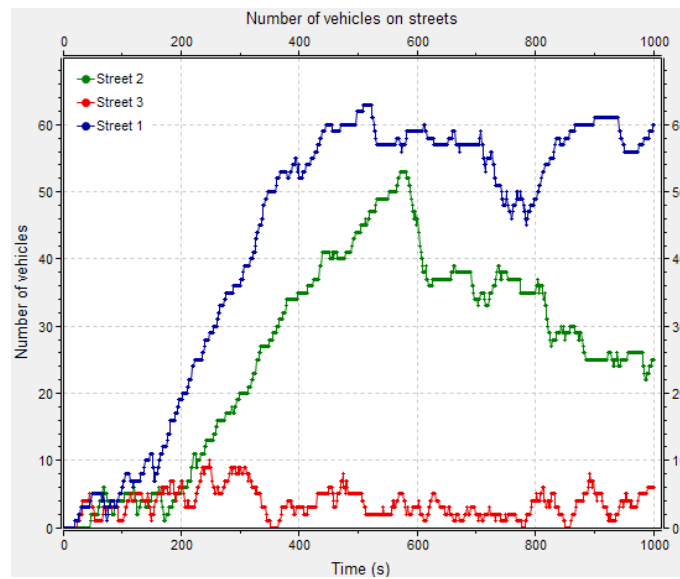

Figure 4.11: The average number of vehicles in the streets on the vehicle’s route.

This section introduced the congestion level quantification mechanism, which we use in presentation of *LA* mechanism as an example application in this thesis. *LA* mechanism is not limited to its use and can be used for dissemination of any other information. Still, since we used it as a case study, in this section we also presented its congestion detection and quantification performance. The presented results are from [68], [69] and show that vehicles are able to detect various levels of congestion, which are later communicated in the network and aggregated by the *LA* mechanism.

#### 4.4.2 Kalman Filtering

VANETs are generally characterised with large number of nodes in the network, since they are usually used in urban areas where the number of vehicles can reach hundreds or even thousands. Because of that, vehicles in the network often receive many messages, and estimating the real picture of the observed phenomenon is a challenging task due to data imperfection, diversity of the sensing technologies and volatile levels of incoming measurements. These factors bring the uncertainty



into the data [70], and we propose the use of estimation technique to enable the vehicles to validate the state of interest, in this case the level of traffic congestion. This section presents theoretical background of the estimation problem and introduces the use of estimation techniques in the *LA* mechanism.

Estimation or data fusion techniques are commonly used in WSNs for tracking and monitoring purposes, or in navigation and statistical inference as well. There are many data fusion techniques [67] and can be classified according to several criteria including data abstraction level, purpose, parameters, data type and mathematical foundation. Based on method's purpose in [67], fusion can be performed with various objectives including inference, estimation, classification, compression, etc. The most commonly used are the probabilistic techniques which present data uncertainties via probabilistic density functions. Estimation techniques include Maximum Likelihood method, Maximum A Posteriori, Least Squares, Moving Average filter, the Kalman filter.

The recursive Bayes estimator or Bayes filter is powerful for dealing with estimation problem and is the most widely used [70]. Based on the gathered data, by calculating the posterior probability density function of the observing state, the filter is able to compute the estimate of the system's state, such as its mean or covariance. When the new measurement arrives, for example when vehicle receives the message, the estimation of the state of the congestion is calculated. The calculation of the state is a recursive process consisting of two phases: prediction and update. To compute the state estimate, the state vector of the system can be represented as a Markovian process, as shown in Figure 4.12 and according to:

$$x_k = f_k(x_{k-1}, v_k) \iff p(x_k | x_{k-1}) \quad (4.12)$$

$x_k$ : State vector at time instant  $k$

$x_{k-1}$ : State vector at time instant  $k-1$

$f_k$ : State transition function at time instant  $k$

$v_k$ : A process noise represented as uncorrelated white Gaussian noise

$p(x_k|x_{k-1})$ : Conditional distribution

Additionally, the incoming measurements should be conditionally independent given the state and can be described as follows:

$$z_k = h_k(x_k, w_k) \iff p(z_k | x_k) \quad (4.13)$$

$z_k$ : Measurement at time instant  $k$

$h_k$ : Measurement function at time instant  $k$

$w_k$ : A measurement noise represented as uncorrelated white Gaussian noise

$p(z_k|x_k)$ : The probability of obtaining the measurements given the state (likelihood function) at time instant  $k$

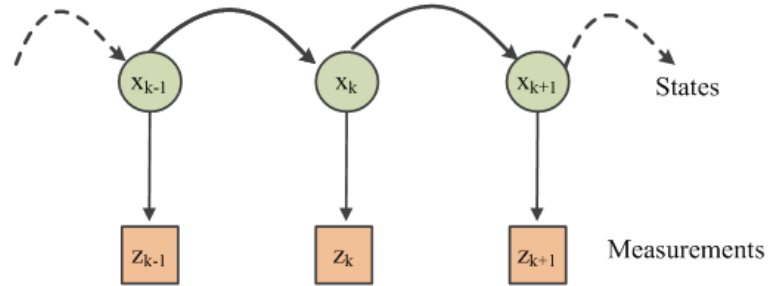

Figure 4.12: Markov process where the states of the system are not visible.

The prediction of the next time step  $k$  is calculated as follows:

$$p(x_k|z_{1:k-1}) = \int p(x_k|x_{k-1}, z_{1:k-1})p(x_{k-1}|z_{1:k-1})dx_{k-1} \quad (4.14)$$

$p(x_k|x_{k-1}, z_{1:k-1}) = p(x_k|x_{k-1})$ : The conditional distribution

$p(x_k|z_{1:k-1})$ : A probability distribution of the state at time  $k$  conditioned on all measurements gathered up to time  $k-1$

$p(x_{k-1}|z_{1:k-1})$ : A previous posterior distribution for time  $k-1$

When the measurements for the time  $k$  arrive, the uncertainty is narrowed and the update can be calculated via Bayes rule where the output is the knowledge for the time instance  $k$  presented by the probability distribution (belief state) as follows:

$$bel(x_k) = p(x_k|z_{1:k}) = p(x_k|z_k, z_{1:k-1}) = \frac{p(z_k|x_k, z_{1:k-1})p(x_k|z_{1:k-1})}{p(z_k|z_{1:k-1})} \quad (4.15)$$

$z_{1:k}$ : Measurements obtained up to time  $k$

$p(x_k|z_{1:k})$ : A probability distribution of the state at time  $k$  conditioned on all measurements gathered up to time  $k$

$p(x_k|z_k, z_{1:k-1})$ : A probability distribution of the state at time  $k$  conditioned on all measurements gathered up to time  $k-1$  and measurement for time  $k$

$p(z_k|z_{1:k-1})$ : Normalisation constant

$p(z_k|x_k, z_{1:k-1})$ : Measurement model

Measurement model and normalisation constant can be calculated as follows:

$$p(z_k|x_k, z_{1:k-1}) = p(z_k|x_k) \quad (4.16)$$

$$p(z_k|z_{1:k-1}) = \int p(z_k|x_k)p(x_k|z_{1:k-1})dx_k \Rightarrow \frac{1}{\eta} \quad (4.17)$$

If (4.16) is rearranged then:

$$bel(x_k) = p(x_k|z_{1:k}) = \eta p(z_k|x_k) \int p(x_k|x_{k-1})p(x_{k-1}|z_{1:k-1})dx_{k-1} \quad (4.18)$$

Similarly, the belief of the state for the time period up to  $k$  is:

$$p(x_{1:k}|z_{1:k}) = \eta p(z_k|x_k)p(x_k|x_{k-1})p(x_{1:k-1}|z_{1:k-1}) \quad (4.19)$$

When the new incoming measurements arrive, the Bayes estimator is ap-

plied and measurements are fused, but the prior distribution and the normalising term contains integrals that generally cannot be analytically evaluated [70]. An analytical solution of the Bayes estimator is available under the assumption that the system dynamics is linear function and that posterior density has a Gaussian distribution. Such solution is the Kalman Filter [71] which is the best linear recursive estimator that calculates an estimate of the state while minimising the mean square error.

Therefore, in the *LA* mechanism we use the Kalman Filter to fuse the incoming measurements and enable the vehicles to estimate the real value of traffic congestion. The Kalman filter allows a detailed description of measurements as a system, depending on the requirements of the application. The system can be described with as many variables as needed, for example intensity, position, location, or something else. This enables to value the latest received measurement the most but to still obtain realistic and optimal estimate, which compared to only saving the latest measurement looks “smoother” and less noisy, as shown in Figure 4.13.

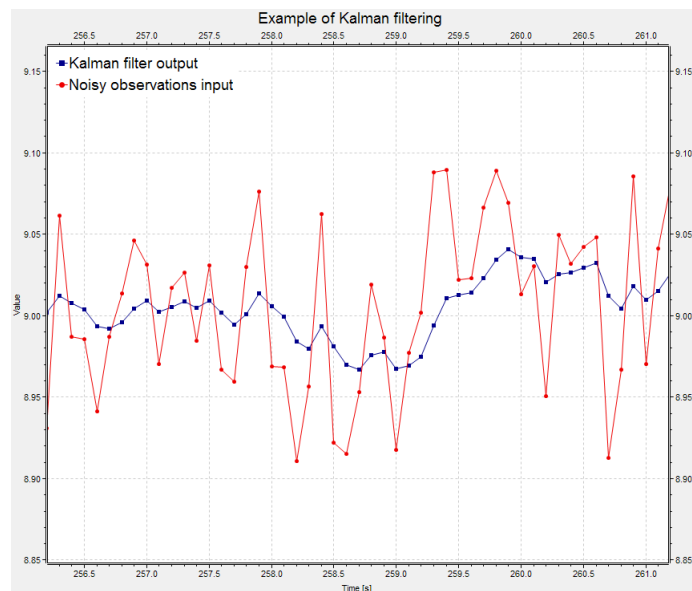

Figure 4.13: Noisy measurements and the Kalman filter estimations.

Each vehicle feeds the Kalman filter with obtained and received measurements in order to fuse them into the *World Model*, without the need for the aggregation period and valuing the latest measurements the most. In our case the observed system state is the congestion level  $M$ , further denoted as  $x$ , which evolves from the state  $x_{k-1}$  to  $x_k$  according to the following equation:

$$x_k = F_k x_{k-1} + B_k u_k + \nu_k \quad (4.20)$$

$x_k$ : System state at time  $k$ , composed of the parameters describing the system (level of congestion)

$x_{k-1}$ : System state at time  $k-1$

$F_k$ : State transition model of the system

$B_k$ : Control input-model for time  $k$

$u_k$ : Control input for time  $k$

$Q_k$ : Process noise covariance for time  $k$

$\nu_k$ : Process noise, where  $\nu_k \sim N(0, Q_k)$

The incoming measurement  $z$  for time step  $k$  vehicle can obtain from other vehicles or on its own and it is defined as follows:

$$z_k = H_k x_k + w_k \quad (4.21)$$

$z_k$ : Measurement (observation) at time  $k$

$H_k$ : Measurement (observation) model at time  $k$

$R_k$ : Measurement noise covariance at time  $k$

$w_k$ : Measurement noise, where  $w_k \sim N(0, R_k)$

It is assumed that process and measurement noises are independent, white and Gaussian in nature, with zero mean and aforementioned covariance defined. Depending on the application, the state transition model, control input and mea-

surement model can be represented in matrix or scalar form. We use the scalar form of the Kalman Filter, where the system state is described with congestion level  $M$ , with no control input signal. It is a recursive process consisted of two stages, the prediction and update (estimation) stage. In the prediction stage, the filter predicts the state and its variance at time  $k$  from the state at  $k-1$  as follows:

$$\begin{aligned}\hat{x}_{k|k-1} &= F_k \hat{x}_{k-1|k-1} + B_k u_k \\ P_{k|k-1} &= F_k P_{k-1|k-1} F_k^T + Q_k\end{aligned}\tag{4.22}$$

$\hat{x}_{k|k-1}$ : Predicted state estimate for time  $k$  based on the information from  $k-1$

$P_{k|k-1}$ : Predicted (*a priori*) estimate error covariance for time  $k$  based on the information from  $k-1$

$\hat{x}_{k-1|k-1}$ : The updated state estimate for time  $k-1$

$P_{k-1|k-1}$ : The updated error covariance for time  $k-1$

Upon the prediction, the update stage is performed when the new measurement arrives. The received measurement narrows down the uncertainty from the prediction step, where the innovation vector and innovation matrix are calculated. The innovation (residual) presents the difference between the true measurement value and its predicted value using the information from the time  $k-1$ . The innovation  $s_k$  for time step  $k$  is calculated with:

$$s_k = z_k - H_k \hat{x}_{k|k-1}\tag{4.23}$$

$s_k$ : The innovation (residual) for time step  $k$

$z_k$ : Measurements for time step  $k$

The innovation for time step  $k$  is characterized with zero mean and the innovation covariance, which is defined as follows:

$$S_k = H_k P_{k|k-1} H_k^T + R_k\tag{4.24}$$

An optimal Kalman Gain for time step  $k$  is calculated with:

$$K_k = P_{k|k-1} H_k^T S_k^{-1} \quad (4.25)$$

Finally, the updated (a posteriori) state estimate or the estimated value of traffic congestion level and error covariance can be calculated as:

$$\begin{aligned} \hat{x}_{k|k} &= \hat{x}_{k|k-1} + K_k [z_k - H_k \hat{x}_{k|k-1}] \\ P_{k|k} &= (I - K_k H_k) P_{k|k-1} \end{aligned} \quad (4.26)$$

Therefore, the nodes fuse received and self-obtained measurements into the *World Model* based on equation (4.26).

## 4.5 Data Dissemination

*Data Dissemination* module is responsible for deciding when the vehicles will broadcast the message. The traditional approach towards message dissemination in VANETs is periodic broadcasting. To avoid periodic broadcasting, some techniques have been proposed previously, and most relevant are clustering and adaptive broadcasting. Clustering [72] is a technique mostly used in WSN to reduce the number of broadcasting nodes, and usually assumes some hierarchy between the nodes which is usually based on nodes location. Some clustering mechanisms were proposed for VANETs [59] featuring the cluster-head selection process. This selection process also induces additional transmissions and communication overhead. Alternatively, there is a concept of the passive clustering, which seems more appropriate, in which the nodes can determine if and when to broadcast based on their own observations and received observations. This approach aligns with the challenges outlined before. In addition, another con-

cept that contributes towards the reduction or adjustment of broadcast activity is adaptive broadcasting. There, the nodes change their broadcast frequency based on local measurements and some threshold. The main goal of *LA* mechanism is to reduce both broadcast frequency and the number of broadcasting nodes in the network, thus both passive clustering and adaptive broadcasting concepts are used as a base for the *LA* mechanism. The nodes will determine if and when they should broadcast the information based on their observations and the received observations. Ideally, only a small percentage of nodes should decide to broadcast while majority should refrain.

Therefore the *Data Dissemination* module uses knowledge from the *World Model* and *LA* technique to retrieve self-detected measurements and received measurements for the current street segment. Then the differential comparison is performed so that *Data Dissemination* module decides whether to broadcast the message or not. The module is called periodically like in periodic broadcasting, however, if the vehicle will actually broadcast or not is entirely based on the decision making process:

$$if (M_o * M_r) = True \text{ and } \theta_o = \theta_r \rightarrow Broadcast \text{ decision} = YES \quad (4.27)$$

The *Broadcast Decision* within the *Data Dissemination* module can have the values of *YES* and *NO* and is reached by the broadcasting algorithm shown in Algorithm 4.2. The symbol  $*$  represents any relationship between the vehicle's own and received measurements referring to the same street section. In our case we want to disseminate the information about the highest level of traffic congestion and therefore we use the greater than relation ( $\geq$ ). Thus the broadcast decision becomes:

$$if (M_o \geq M_r) = True \text{ and } \theta_o = \theta_r \rightarrow Broadcast \text{ decision} = YES \quad (4.28)$$



This condition ensures that every vehicle will only broadcast the message if its own detected congested value is greater than the value it received from other vehicles about the same street section. It provides location-centric periodic updates, achieved by using the combination of passive clustering and adaptive broadcasting of the vehicles. The clustering is achieved by using the current direction angle  $\theta$  of the vehicle obtained by the *LA* technique, where all the vehicles with the same  $\theta$  belong to the same cluster. The passiveness of clustering, and eventual adaptation of broadcast interval is achieved by refraining the vehicles of broadcasting according to the *Broadcast Decision*. With this approach, each broadcast decision of every vehicle has location context attached, resulting in reduced number of broadcasts per street section. Contrary to the *LA* mechanism, in periodic broadcasting, as used by most of the schemes, broadcast decision is always *YES*- Algorithm 4.3.

In Algorithm 4.2 the vehicle's check whether its own detected level of congestion is greater than level of congestion it received from other vehicles for the same street segment is performed every *broadcastInterval*. The vehicle retrieves the *currentDirection* of its current street segment, and stores it in the variable *location*. Then own measurements referring to the *location* are retrieved and stored in  $M_o$ . The vehicle also retrieves the received measurements for *location* and stores it in  $M_r$ . The broadcast decision from (4.27) is implemented with *if* condition, where  $M_o$  and  $M_r$  are compared. In case  $M_o$  is greater than  $M_r$ , the vehicle sets the *broadcatDecision* to *yes* and broadcasts the message, and *time* is set to zero. If not, the *broadcastDecision* is set to *no* and *time* is incremented. On the other hand, in Algorithm 4.3 the *broadcastDecision* will be set to *yes* every *broadcastInterval*.

Chapter 4 introduced the contribution of the thesis, the *Location Aware Data Aggregation Mechanism* that enables efficient dissemination of messages in VANETS. The mechanism is based on modified *Generic Modelling Approach*,

**Algorithm 4.2** Data dissemination - The *LA* mechanism

---

```
1: procedure LA MECHANISM
2:   initialise(timer=0)
3:   if timer > broadcastInterval then
4:     location=get(currentDirection)
5:      $M_o$ =get(ownMeasurement(location))
6:      $M_r$ =get(receivedMeasurement(location))
7:     if (( $M_o > M_r$ )==True) then
8:       broadcastDecision=yes
9:       timer=0
10:    else
11:      broadcastDecision=no
12:      timer=timer+1
13:    end if
14:  else timer=timer+1
15:  end if
16: end procedure
```

---

**Algorithm 4.3** Data dissemination - Periodic broadcasting

---

```
1: procedure LA MECHANISM
2:   initialise(timer=0)
3:   if (timer > broadcastInterval) then
4:     broadcastDecision=yes
5:     timer=0
6:   else
7:     broadcastDecision=no
8:     timer=timer+1
9:   end if
10: end procedure
```

---

consisted of five modules which were separately presented: *Localisation*, *World Model*, *Fusion*, *Dissemination* and *Decision*. Additionally, in the *Fusion* module, the case study application of traffic congestion detection and quantification used in this thesis was introduced together with some of its performance analysis from [68], [69]. In Chapter 5, an extensive evaluation of the *LA* mechanism is performed and conclusions about *LA*'s performance are made.

# Chapter 5

## Performance Evaluation

### 5.1 Simulation Tools

Realistic simulation of VANETs is one of the major challenges in this research domain [73]-[75]. This is due to the fact that VANET is a relatively young research area and the number of simulators supporting existing DSRC standard is limited. The additional obstacle is in the actual VANETs scenarios where simulator needs to be able to simulate realistic mobility of the nodes according to some traffic pattern in real environment, for example urban. Traditional network simulators are not able to perform such tasks and their offer of available mobility models is limited. They usually include some basic models which are commonly used in other more widely analysed networks such as WSNs or MANETs. One popular example of a mobility model is the Random Waypoint Model [76], which does not represent a realistic approximation of car's mobility. Apart from the built-in mobility models, network simulators often offer the option of importing the mobility traces files into network simulation. This makes the nodes in the network simulator move as defined in this file. Mobility traces are obtained as an output from traffic mobility simulators which are used in transportation sci-

ence and industry, to evaluate traffic load in certain environment. Simulating VANETs with mobility traces is a better option than using basic mobility models developed for other network types. One of the early examples of such simulators combined mobility traces obtained from VISSIM simulator with well-known network simulator NS-2 [77]. However, such simulation does not allow real time integration of traffic movement on the vehicles and exchanged information that is communicated in the network. Therefore it is unable to simulate how the content of the communicated messages impacts driver's mobility. For example if vehicle receives an emergency message indicating that road on its route is blocked, the vehicle cannot change its route because mobility traces are imported and fixed. Alternatively, traces might be obtained from real measurements, however the same problem still stands. This brought the need of developing a simulator for VANETs which can make real time connection between the simulating the communication and simulating the mobility of the vehicles. The main reason is that offline simulation can only evaluate the impact of mobility of road traffic on the network traffic, but not vice versa [78].

To achieve simulation that enables a two way influence between the road and the network traffic, bidirectional coupling between network and traffic simulator is needed [73]. One such example is Vehicles in Network Simulation (VEINS) [75] simulator, which couples well-known network simulator OMNeT++ [78] and well-known road traffic simulator SUMO [79]. OMNeT++, SUMO and Veins are open source and free for academic use under the GPL license. Veins is based on OMNeT++ simulator and MIXIM [80] framework extension for simulation of wireless standards, protocols and networks. OMNeT++ simulation framework is consisted of a hierarchy of C++ reusable modules whose relationships and communication links are written in the Network Description (NED) language and stored in the NED files. The communication links and relationships can be modelled graphically as well. The MIXIM framework is designed specifically

for wireless mobile ad hoc networks and supports standards such as traditional 802.11 and 802.15. The authors of [75] extended MIXIM to support complete DSRC 802.11p standard together with all underlying protocols, such as WSMP protocol. Apart from developing the support for the standard they also developed real time integration with SUMO simulator via TraCI module [81], from SUMO which is achieved through TCP/IP connection. The relationship between all the simulators involved is shown in Figure 5.1.

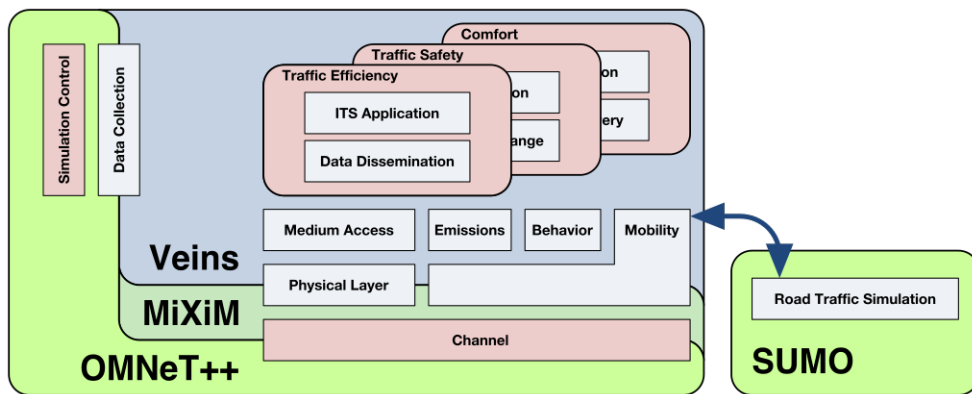

Figure 5.1: Relationship of OMNeT++, SUMO, MiXiM and Veins simulators [82].

Such integration of simulators provides the option to stop the vehicles within the simulation and simulate traffic accident and jams which can be detected by other vehicles and then re-routed around that place. Generally speaking, road traffic mobility simulators can support Macroscopic, Mesoscopic, and Microscopic mobility models, depending on the granularity of the simulated traffic flows. The focus of VANETs is on the behaviour of individual vehicles, both in the context of mobility and in the context of communication. Thus, it is necessary to have detailed information about vehicle's mobility. This can only be achieved with microscopic mobility model which specifies mobility of every vehicle individually. There are a number of such microsimulation models developed in transportation area including the well-known Cellular Automaton (CA) model [83] and the car-following model by Stefan Krauß (SK) [84]. As stated in [75] these models were evaluated in [85], where it has been found that as far as network simulation is concerned, both are of equal value as a mobility model. Traffic simulations in

SUMO are performed using the SK model. These simulations allow simulating both in command line and GUI. SUMO also allows manual building of road networks or their import from maps such as Open Street Map [86]. Additionally, the network can include various traffic rules and objects such as traffic lights, signs, induction loops, pedestrians, etc. Most importantly it allows modelling or importing of buildings which are then in OMNeT++ interpreted as obstacles thus making the radio propagation more realistic. Finally, the user has total freedom in specifying the vehicles mobility from the routes, street sections on the route to speed, acceleration, etc. Additionally, the simulator even calculates the vehicles' emission level, which can be obtained in real-time in OMNeT++. There are also predefined vehicle types which specify aforementioned parameters.

Figure 5.2 and Figure 5.3 present screenshots of user interface of OMNeT++ and SUMO, respectively. To summarise, SUMO is responsible for the movement of the nodes initially and OMNeT++ can change the vehicles mobility parameters depending on the simulated application scenario. Finally, in addition to Veins we used Vacamobil [87] framework which is built on top of Veins and provides some additional features such as keeping the number of nodes in the simulation constant.

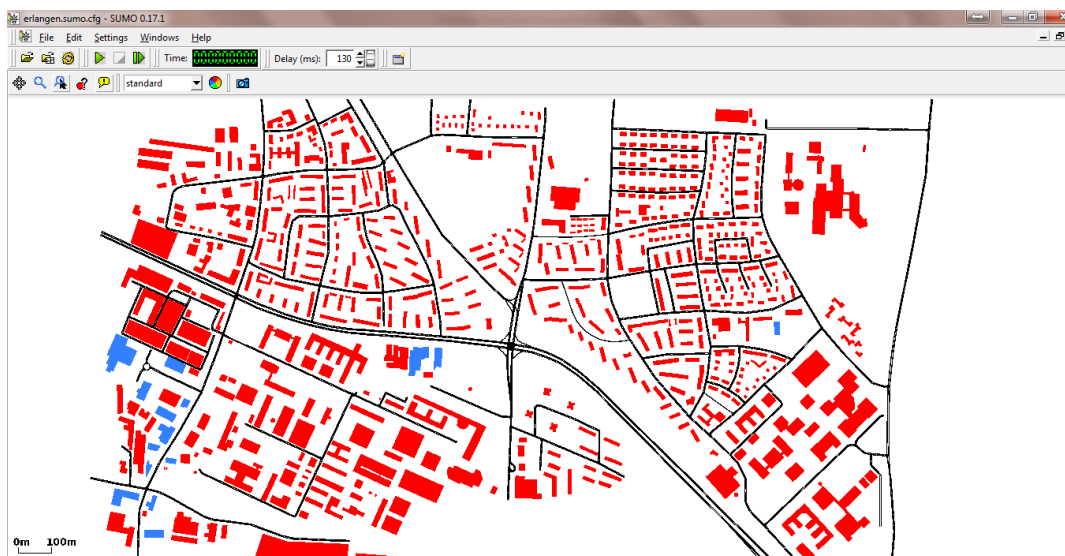

Figure 5.2: SUMO screenshot.

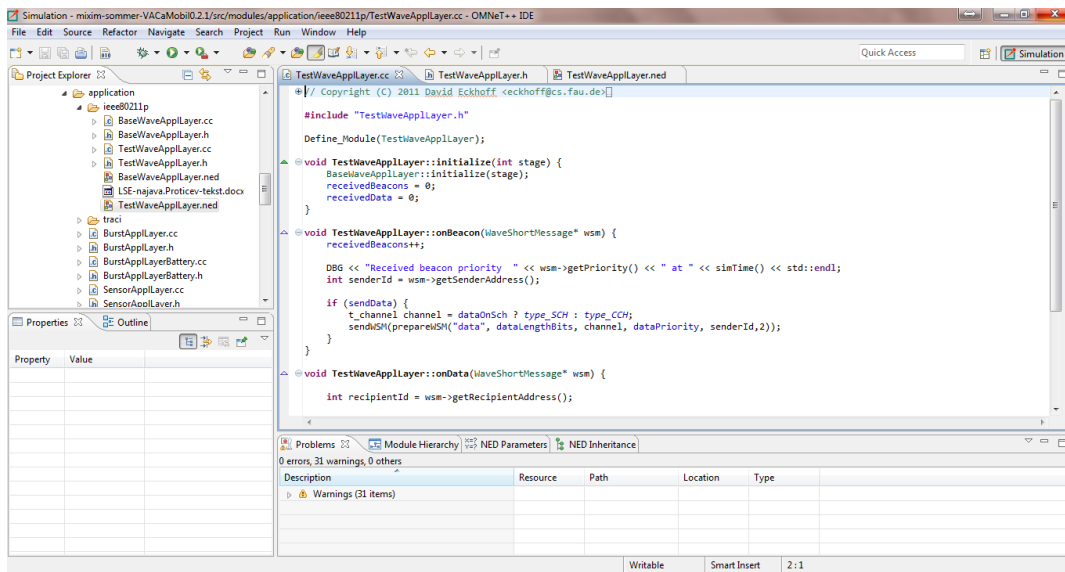

Figure 5.3: OMNeT++ screenshot.

## 5.2 Simulation Setup

The performance evaluation of the proposed data aggregation mechanism is based on a comprehensive simulation of a real city scenario and VANET based on 802.11p standard. For this purpose previously introduced Veins simulation framework [75] was used because it is designed specifically for VANETs, supports full 802.11p standard and enables real-time integration with the traffic mobility simulator. The scenario used for the simulation is based on real map of the city of Erlangen in Germany, which is included in the Veins simulator. The map realistically represents urban environment and includes buildings which make radio propagation similar to a real scenario, and thus directly influences the dissemination of messages. The map of Erlangen is showed in Figure 5.4.

There are three simulation scenarios with different traffic densities used for evaluation of our mechanism: low with 300 vehicles, medium with 600 and high with 1050 vehicles. Figure 5.5 shows the number of vehicles during the simulation time which we set to 600s. Choosing a longer simulation time would make more vehicles end their journey and exit the simulation before the simulation time

expires.



Figure 5.4: Erlangen city map taken from Veins simulator.

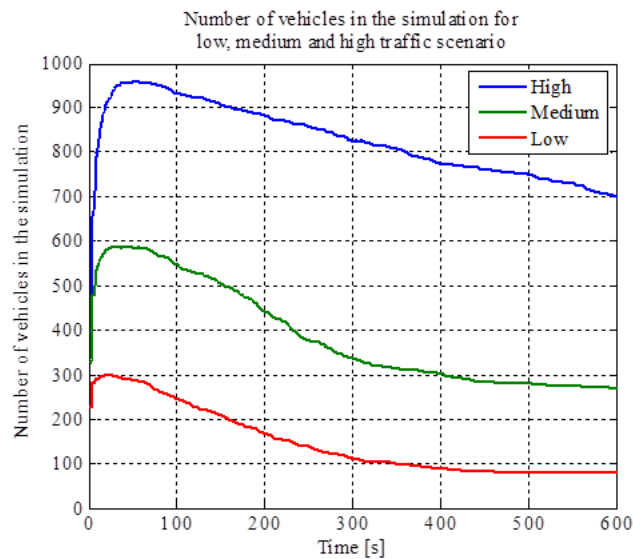

Figure 5.5: The number of vehicles in low, medium and high traffic densities.

Therefore, the total number of vehicles in the simulation would significantly decrease and compromise the dissemination process in all the evaluated schemes. Further, we deliberately chose not to keep the number of vehicles in the simulation constant in order to evaluate algorithms in varying traffic densities. Every vehicle has its own route, chosen from the randomly generated set of routes representing



the realistic situation in which vehicles have independent routes. The vehicles are not inserted simultaneously into the simulation. Some of them enter the simulation sooner and exit the simulation sooner than the others and vice versa, which causes the graphs on Figure 5.5 to descend.

The simulation setup parameters are shown in Table 5.1. The vehicles in the simulation used the proposed data aggregation mechanism with the knowledge depth parameter set to  $K=3$  and granularity parameter set to  $g=12$ . The vehicles in the simulation measured the traffic congestion level as described in Chapter 4.

Table 5.1: Simulation parameters.

Road Traffic Density	Low/medium/high
Number of vehicles	300/600/1050
Total city area	2.25 km x 2.25 km ( $\sim 5\text{km}^2$ )
Communication standard	IEEE 802.11p
Tx power	10 mW
Rx sensitivity	-89 dBm
MAC Bit rate	18 Mb/s
Granularity parameter	12
Knowledge depth	3
Broadcast interval for PB	15s

The proposed *LA* mechanism was evaluated via simulation together with the simulation of two additional reference mechanisms. One of them is a standard periodic broadcasting mechanism (*PB*) which is used in most of the aggregation schemes. The second reference mechanism is *DA2RF*, which reduces the network load by restricting forwarders based on the position of the vehicle's neighbours. Here the vehicle flags itself as non-forwarder if there is a forwarder in front and behind. *DA2RF* was chosen as a reference mechanism because its main contribution to communication efficiency is via reduction of the nodes' broadcasting activity, same as *LA*'s. The analysis of their performance is presented in Section 5.3.

### 5.3 Simulation Results

The performance analysis of the *PB*, *DA2RF* [12] and *LA* mechanisms consists of nine simulations – three simulations per mechanism, each of them performed for low, medium and high density of the network. In all three mechanisms the vehicles use location awareness technique, send the same types of messages and move on the same routes. The only difference between the simulations is in the nodes' broadcasting activity. In the *PB* scenario all nodes use periodic broadcasting with a 15s period, whilst in the *LA* and *DA2RF* the broadcasting is adaptive based on the mechanisms. Further, the results are presented in a way that the *PB* scheme is taken as a reference point because it will provide the best propagation of the messages due to constant broadcasting activity of the nodes. On the other hand, the performance of the *LA* and *DA2RF* is compared to the *PB* individually, as will be explained later. Two aspects of the mechanisms have been evaluated:

- **Efficiency** – the impact of the data aggregation mechanism on network performance is evaluated by recording the number of sent and received messages, broadcast frequency distribution per nodes, lost packets and times that nodes went into back-off procedure. We also test the clustering communication efficiency to understand the spatial distribution of the communication benefits.
- **Accuracy** – the impact of the data aggregation mechanism on accuracy of disseminated information is evaluated by observing the difference of vehicle's knowledge about the network in two scenarios.

### 5.3.1 Efficiency

In order to evaluate how the proposed mechanism reflects on the network load, the overall network parameters of the *LA* and *DA2RF* mechanisms are compared for three network densities. Figure 5.6, Figure 5.7 and Figure 5.8, show the results for low, medium and high network density respectively. The results present average number of sent messages, received messages, the number of times vehicle went into back-off procedure and the number of lost packets per node. To better understand how the results of the *LA* and *DA2RF* stand against periodical broadcasting, every value in both the *LA* and *DA2RF* is normalised to the results of the *PB* mechanism, and they refer to the percentage of values obtained by using the *PB* mechanism.

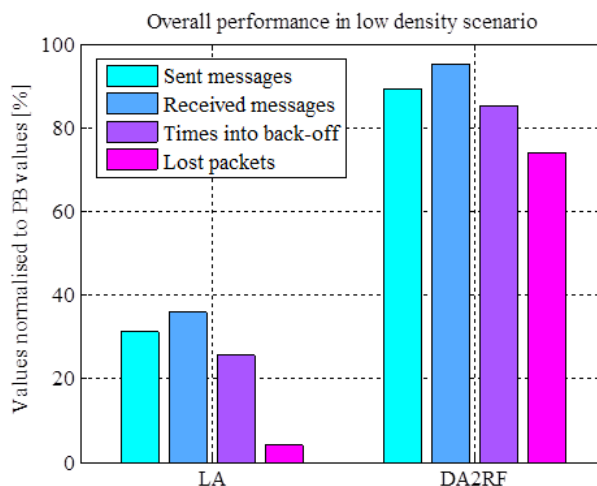

Figure 5.6: Overall simulation results in low density scenario (300 vehicles).

Comparison of the results of the *LA* and *DA2RF* shows significantly better performance of the *LA* mechanism for all evaluated parameters. The *LA* mechanism, depending on the density, performs three to four times better than the *DA2RF* mechanism in terms of the number of the sent messages. A reason for better performance of the *LA* mechanism is that it considers the content of the exchanged messages and accordingly adjusts the broadcasting activity of every node individually based on individual observations and traffic congestion in their

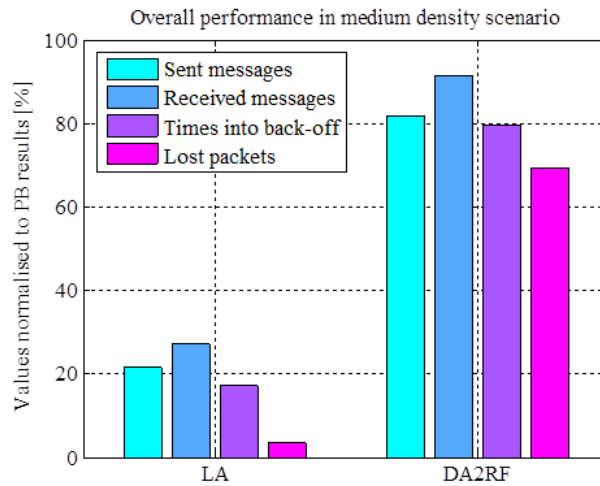

Figure 5.7: Overall simulation results in medium density scenario (600 vehicles).

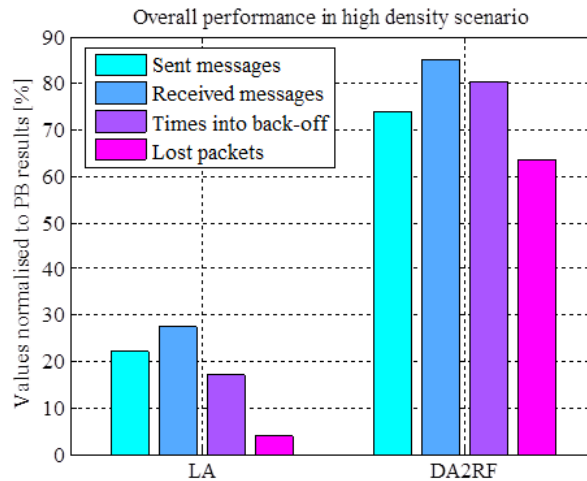

Figure 5.8: Overall simulation results in high density scenario (1050 vehicles).

current street segment. As per the *LA* mechanism, the node will only broadcast the message if it detects higher level of congestion than its neighbours detected. Reduced number of sent messages further results in a smaller number of received messages. As a consequence, there is less contention activity among the nodes for the wireless medium. Eventually this results in smaller number of nodes initiating a back-off procedure and a smaller number of lost packets in the communication. According to the figures, the performance of both mechanisms is better when the density is higher. This means that the schemes reduce the broadcast activity more in such denser scenarios.

To further examine the broadcast activity of individual vehicles in the network, we calculate the broadcast frequency of every vehicle. Broadcast frequency is calculated as a ratio of the number of sent messages and the time interval the vehicle spent in the simulation. Since the broadcast interval in the *PB* mechanism was set to 15 seconds, the majority of the vehicles have broadcast frequency 0.067 ( $=1/15$ ) messages/s. We focus on evaluating the broadcast frequency of all nodes in simulations of the three traffic densities, where we calculate and record the broadcast frequencies of every node. The frequencies of the nodes are then plotted as a histogram where we see the overall performance by observing the distribution of the broadcast frequencies. Figure 5.9, Figure 5.10 and Figure 5.11 show these distributions results for low, medium and high density network respectively.

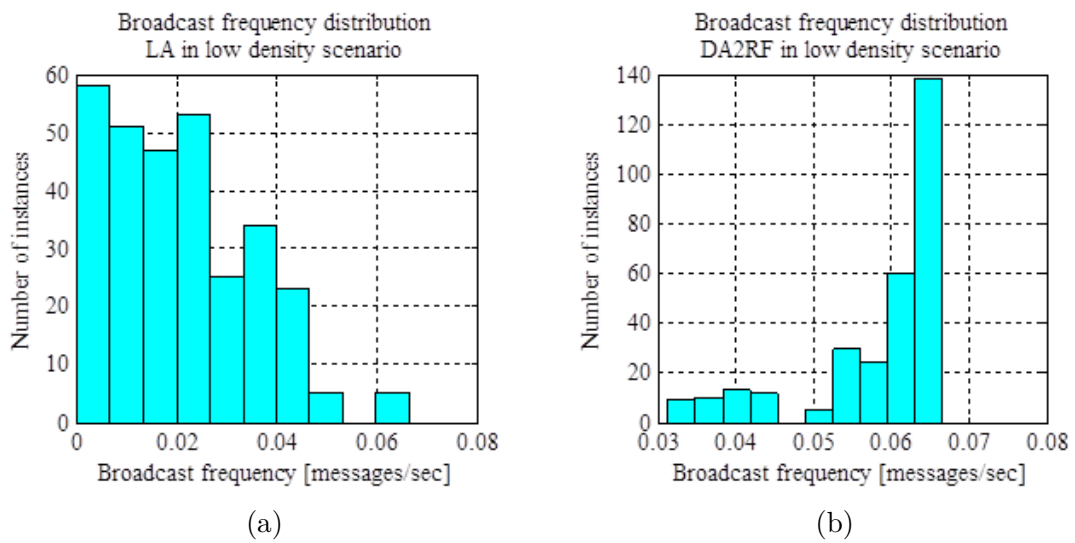

Figure 5.9: Broadcasting frequency distributions of all nodes for the *LA* (a) and *DA2RF* (b) mechanisms in low density scenario.

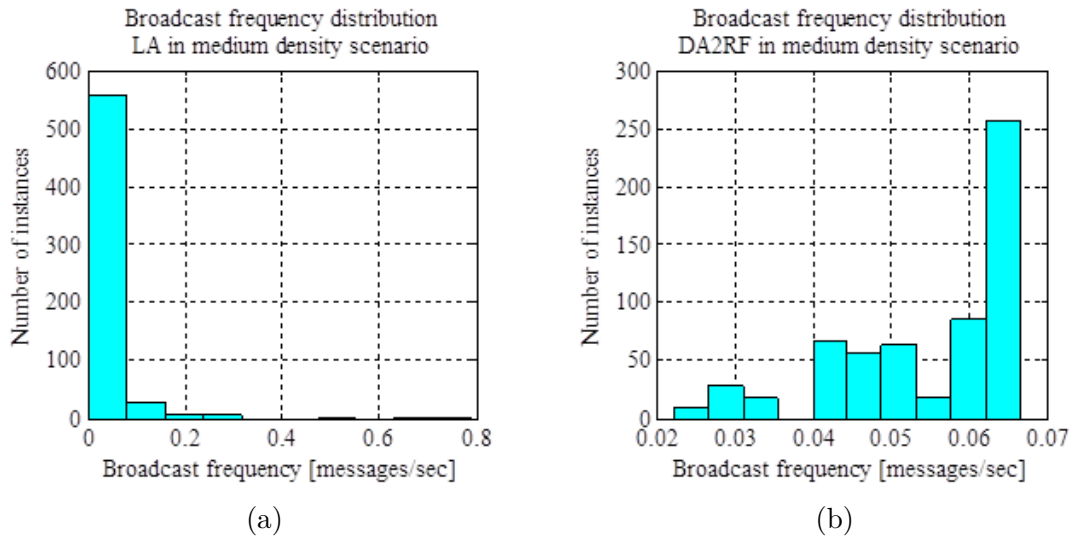

Figure 5.10: Broadcasting frequency distributions of all nodes for the *LA* (a) and *DA2RF* (b) mechanisms in medium density scenario.

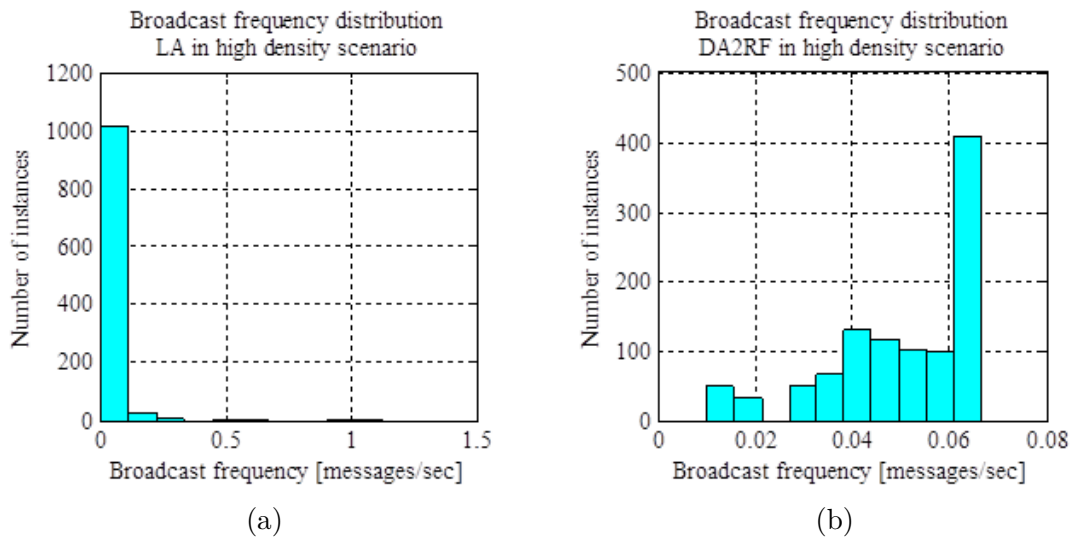

Figure 5.11: Broadcasting frequency distributions of all nodes for the *LA* (a) and *DA2RF* (b) mechanisms in high density scenario.

The first thing to notice when observing the figures is that the *LA* mechanism results are mainly concentrated in the left half of the  $x$  axis, towards the lower broadcasting frequencies. Contrary to the *LA* mechanism, the *DA2RF* mechanism has most of its values distributed in the right part of the  $x$  axis in the last slot on the scale. This means that majority of the vehicles in the *LA* mechanism have low broadcast frequency whilst the majority of the vehicles in the *DA2RF* mechanism have high broadcasting frequency. For example, in Figure 5.9a the number of vehicles with the maximal broadcast frequency is only five. The other vehicles are distributed in the lower part of the  $x$  axis with almost sixty vehicles in the lowest band. By observing the performance of *LA* mechanism it can be noticed that similar trend of having the small number of frequent broadcasters who behave as cluster-heads is getting more obvious as the network density increases. This shows the clustering effect of *LA* mechanism where only limited number of vehicles have high broadcast frequency, whilst the most of them broadcast significantly less. In the high density scenario 1000 vehicles are in the lowest frequency range whilst the other 50 have higher frequencies, meaning that 5% of the vehicles took the largest part in disseminating the messages in the network, while the others were pretty inactive. Overall, these results show that the *LA* mechanism induces significantly lower network load than the *DA2RF* mechanism.

Apart from the overall analysis of the broadcast activity of the vehicles, it is important to understand how the broadcast activity in both simulations is spatially distributed in terms of the aggregation structures such as street segments and city blocks. To spatially examine the broadcast activity we introduce the measure of *Spatial Communication (SC)* and define it as:

$$SC = \frac{\text{Number of sent messages}}{\text{Number of traversed street segments}} \quad (5.1)$$

*SC* represents the average number of sent messages per segment per node and

shows the average communication activity per street segment. We calculate the average  $SC$  value per node and record it over time. Ideally,  $SC$  should be as low as possible because it means that the majority of the nodes have a smaller communication activity. We recorded the  $SC$  values for the  $LA$ ,  $PB$  and  $DA2RF$  mechanisms. In all simulations, nodes use the  $LA$  technique for location awareness and segmentation of the roads. Figure 5.12, Figure 5.13 and Figure 5.14 show that the  $LA$  mechanism achieves the smallest number of broadcasts per segment, which is always less than one, for all three traffic densities.

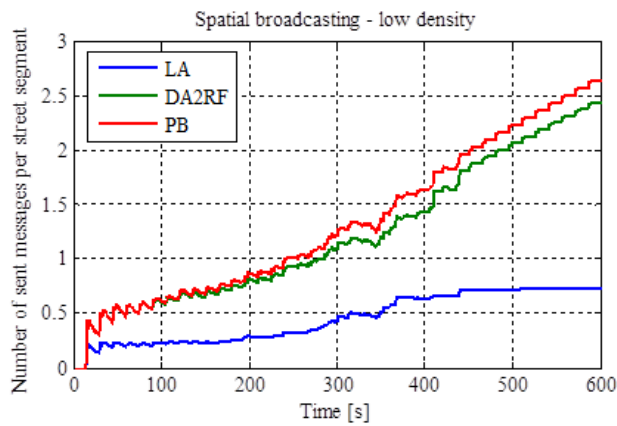

Figure 5.12: *Spatial Communication* in low density scenario for the  $LA$ ,  $DA2RF$  and  $PB$  mechanisms.

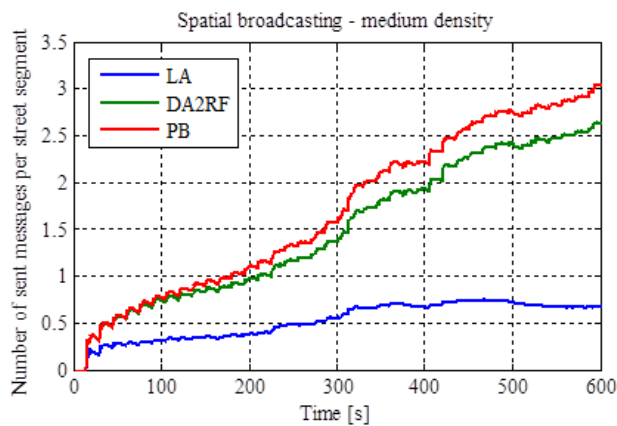

Figure 5.13: *Spatial Communication* in medium density scenario for the  $LA$ ,  $DA2RF$  and  $PB$  mechanisms.



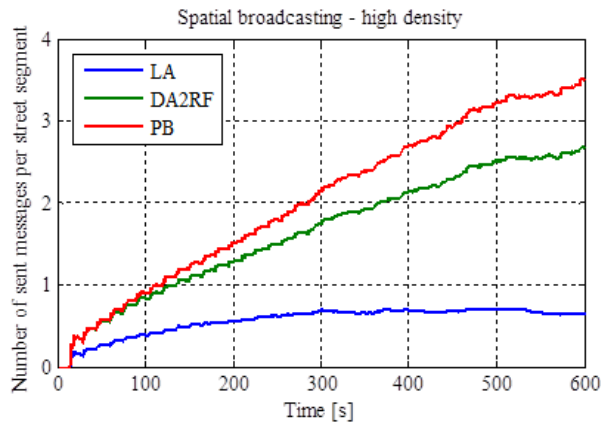

Figure 5.14: *Spatial Communication* in high density scenario for the *LA*, *DA2RF* and *PB* mechanisms.

This means that an average vehicle will refrain from broadcasting if using the *LA* mechanism while in case of the *PB* this number is at least three times higher. More importantly *LA* mechanism keeps the *SC* constant over time, whilst in other two cases the *SC* value increases. The reason for this increase is that the nodes in the *PB* broadcast periodically and the number of sent messages increases steadily. The *DA2RF* mechanism performs almost similarly, though slightly better than the *PB*. Again, it can be noticed that both the *LA* and *DA2RF* mechanisms perform better in denser scenarios.

Now that the good spatial performance of the *LA* mechanism has been shown, we want to compare its performance of location awareness and road segmentation to traditional approach with GPS and digital map. The goal of *LA* mechanism is not to provide precise location awareness like for example exact coordinates, but only awareness about the number of traversed street segments. Thus, the simulations were performed when the vehicles use GPS and the digital map of Erlangen which has pre-defined fixed road segments with unique identifiers. We calculate the average number of street segments per vehicle in both GPS and the *LA* case for the three traffic densities, Figure 5.15, Figure 5.16, Figure 5.17.

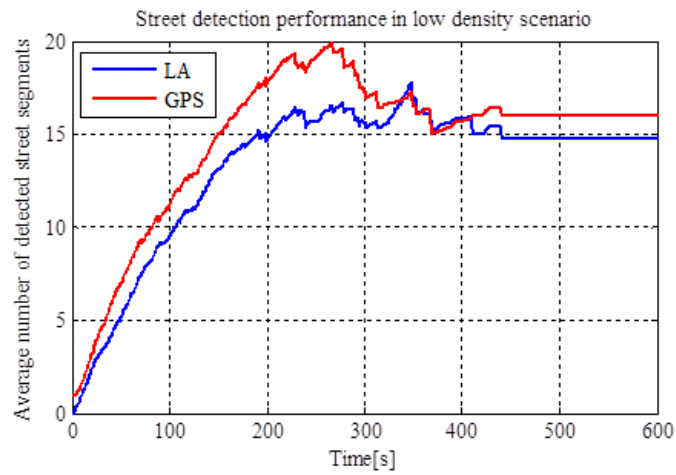

Figure 5.15: Average number of detected street segments in low density scenario.



Figure 5.16: Average number of detected street segments in medium density scenario.

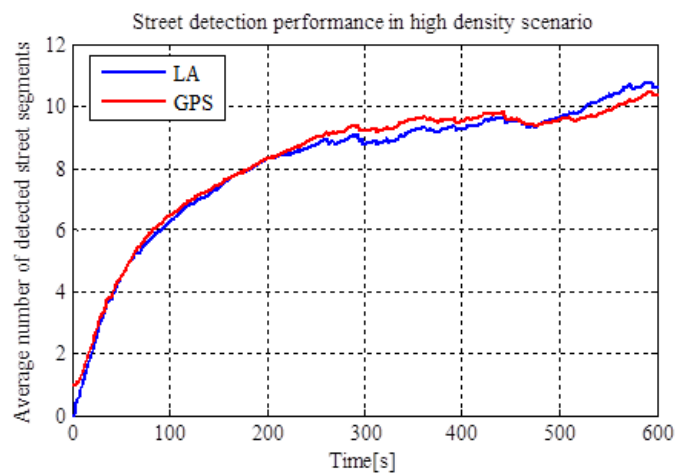

Figure 5.17: Average number of detected street segments in high density scenario.

The results show that average number of detected street sections per vehicle using the *LA* technique is almost the same as detected by the GPS system with digital maps. The meaning of this result is that with *LA* technique without GPS is possible to achieve approximately the same level of spatial understanding in terms of traversed street segments as with GPS. Moreover, *LA* technique does not require any apriori knowledge about the road network such as IDs of the street segments. The advantage of the *LA* mechanism is that the vehicles require database with only a limited number of slots (variables in the memory), in this case 36, which are enough to get the understanding of the immediate vehicle's surrounding. Note that *LA* mechanism is evaluated with granularity parameter  $g=12$  and knowledge depth parameter  $K=3$ , and by increasing these parameters a higher precision can be achieved. On the other hand, the digital map requires separate database slot for every street segment. Therefore, the processing of the data and maintenance of the database is less complex with the *LA* mechanism, which directly impacts the nodes operation in terms of battery and processing power. Finally, these results show that data aggregation can be done without on-board GPS systems, which also reflects on the cost efficiency of such system.

### 5.3.2 Accuracy

While it reduces the network load, the data aggregation mechanism should not compromise the accuracy of the disseminated information. To test the accuracy, the values of vehicles' *World Model* (*WM*) in the case of the *LA* and the *DA2RF* mechanisms are compared to the case when the *PB* mechanism is used. Since the *PB* mechanism is chosen as a reference for the "best" way to disseminate the messages, we introduce the error  $E$  as a metric of accuracy as:

$$E(i) = WM_{PB}(i) - WM_{LA/DA2RF}(i) \quad (5.2)$$

$$i \in \mathbb{Z}, i=1\dots(g \cdot K)$$

Since the *World Model* provides the knowledge about the congestion in the vehicle's neighbourhood we want to measure the accuracy of this knowledge provided by both the *LA* and *DA2RF* mechanisms. Therefore we define error  $E(i)$  for the value in each *World Model* slot individually as a difference between the values of the same slots of the same vehicle recorded during two scenarios, the *PB* and *LA* when considering the *LA* mechanism, and the *PB* and *DA2RF* when considering the *DA2RF* mechanism. This measure provides an insight into the variation of the node's neighbourhood congestion knowledge once data aggregation is used. All vehicles use the same routes in both simulations, thus their movement will be the same and only their broadcasting activity will differ, which will affect the neighbourhood knowledge. Thus, we basically, examine the neighbourhood knowledge difference that is caused by the use of the *LA* and *DA2RF* mechanisms compared to the knowledge when the *PB* is used. In our example  $g=12$  and  $K=3$ . This means that there are 36 slots per vehicle and  $N=300/600/1050$  vehicles, to reflect low, medium and high vehicle density, respectively. To analyse the overall performance we define the average error per vehicle as:

$$E_{AVG} = \frac{\sum_{i=1}^N \sum_{i=1}^{g \cdot K} E(i)}{g \cdot K \cdot N} \quad (5.3)$$

$E_{AVG}$  is calculated and normalised to the maximum value of the traffic congestion level 10, thus the results shown in the figures in this section relate to the percentages. Figure 5.18, Figure 5.19 and Figure 5.20 show the results of average errors for the *LA* and *DA2RF* mechanisms in low, medium and high density networks, respectively. In the accuracy evaluation we focus on evaluating the errors values over time. In all three figures it can be seen that error values are always under 5% for both the *LA* and *DA2RF* in all traffic densities. The comparison shows that in terms of error induced, the *DA2RF* mechanism performs better than the *LA*. This is due to the fact that the number of sent messages by the *DA2RF* is around four times higher than the *LA*, and only 20% less than in the

*PB* mechanism. As discussed in Chapter 3, the cost of achieving communication efficiency is loss of accuracy. This trade-off between communication accuracy and efficiency needs to be controlled without severely impacting the communicated information.

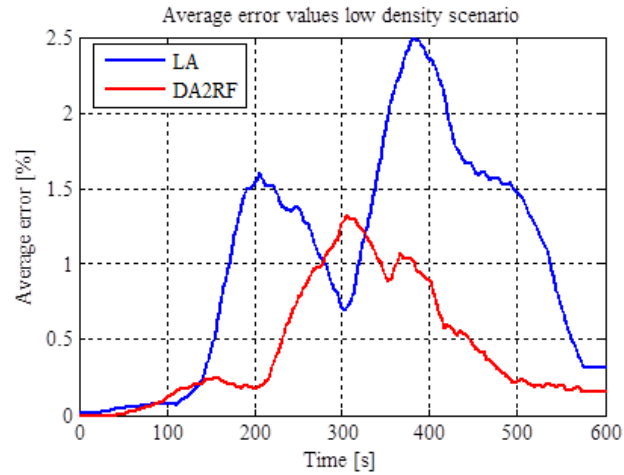

Figure 5.18: Average error values of the *LA* and *DA2RF* mechanisms in low density scenario.

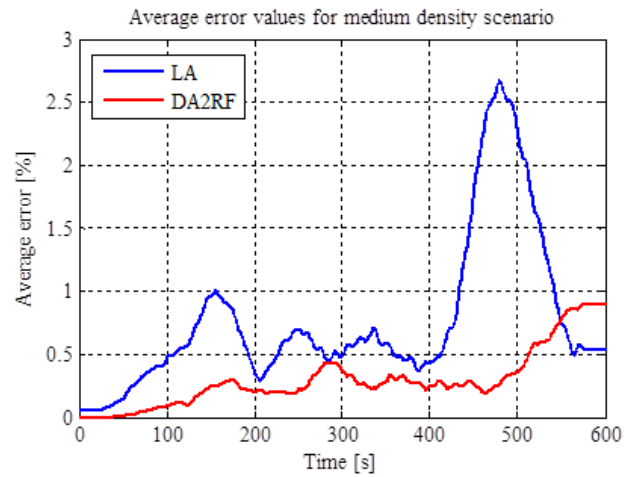

Figure 5.19: Average error values of the *LA* and *DA2RF* mechanisms in medium density scenario.

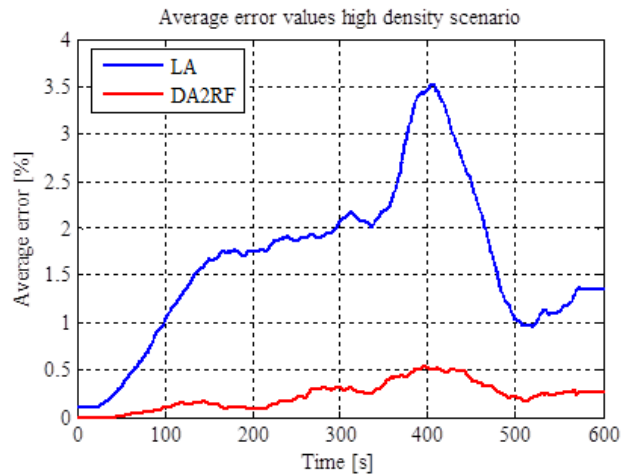

Figure 5.20: Average error values of the *LA* and *DA2RF* mechanisms in high density scenario.

As can be seen in the figures, the *LA* mechanism is capable of achieving such a compromise. The results show that it is possible to design a communication system to significantly reduce the communication overhead while keeping the accuracy of the information at a very high level. Since the figures show the average values for 300, 600 and 1050 vehicles and 36 database slots in each of the vehicles, it is difficult to identify a clear trend in these graphs. Figure 5.21

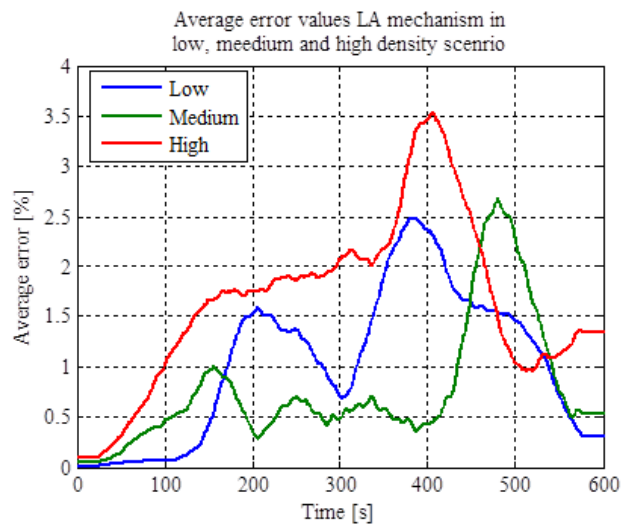

Figure 5.21: Average error values of the *LA* mechanisms in low, medium and high density scenario.

summarises the performance of the *LA* mechanism from the three previous figures in order to see if there is any trend related to the change of the network density. As seen on Figure 5.21, the error value is highest when the network density is high. The reason for such behaviour is that the aggregation mechanism reduces the communication overhead more when the network density is higher. Therefore, the error value is higher as well.

To further examine the spatial distribution of errors, we performed additional analysis which shows the error breakdown per hop for the three hops in the scenario, Figure 5.22.

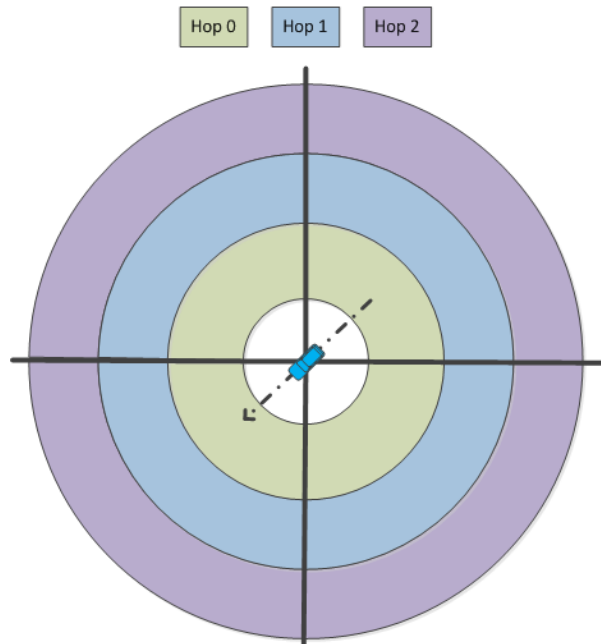

Figure 5.22: Definition of Hop 0, Hop 1 and Hop 2.

Each hop refers to 12 database slots where Hop 0 refers to the messages that come from vehicles that are within the communication range of the observed vehicle. This reflects the streets closest to the vehicle. Hop 1 refers to the previous streets of vehicles within the communication range of a vehicle, while Hop 2 refers

to the streets before the previous one. Errors per hop are defined as:

$$E_{H_j} = \frac{\sum_{i=1}^N \sum_{g=1}^g E(i)}{g \cdot N}, \quad j = 1, \dots, K \quad (5.4)$$

First, we examined the *LA* and *DA2RF* mechanism in all scenarios, as shown in Figure 5.23 and 5.24 and 5.25.

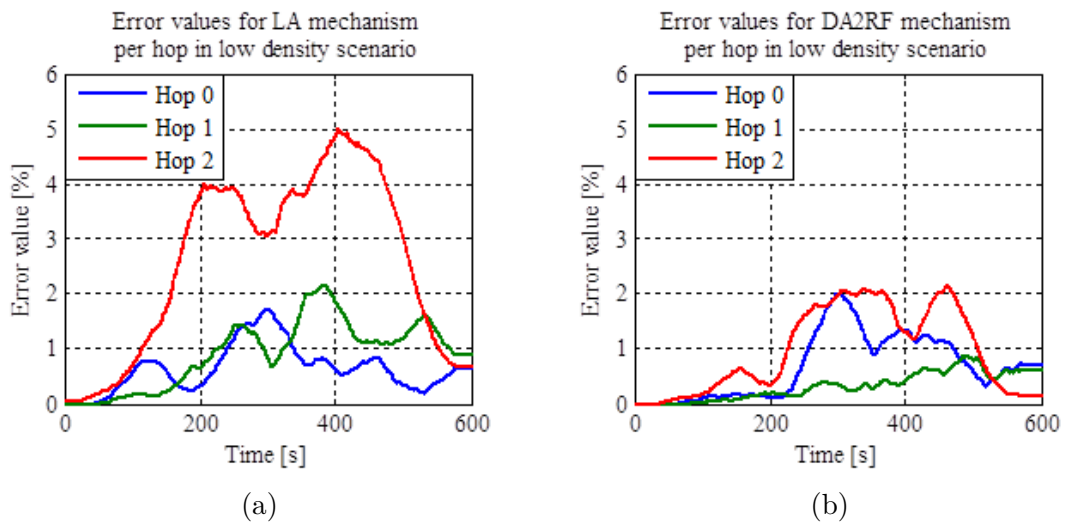

Figure 5.23: Per hop error values for the *LA* (a) and the *DA2RF* (b) mechanisms in low density scenario.

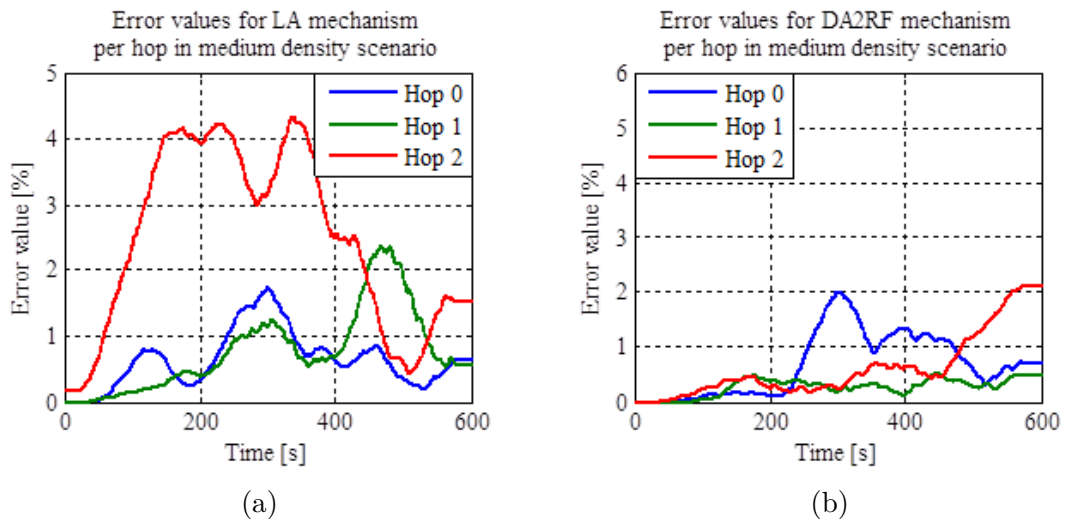

Figure 5.24: Per hop error values for the *LA* (a) and the *DA2RF* (b) mechanisms in medium density scenario.



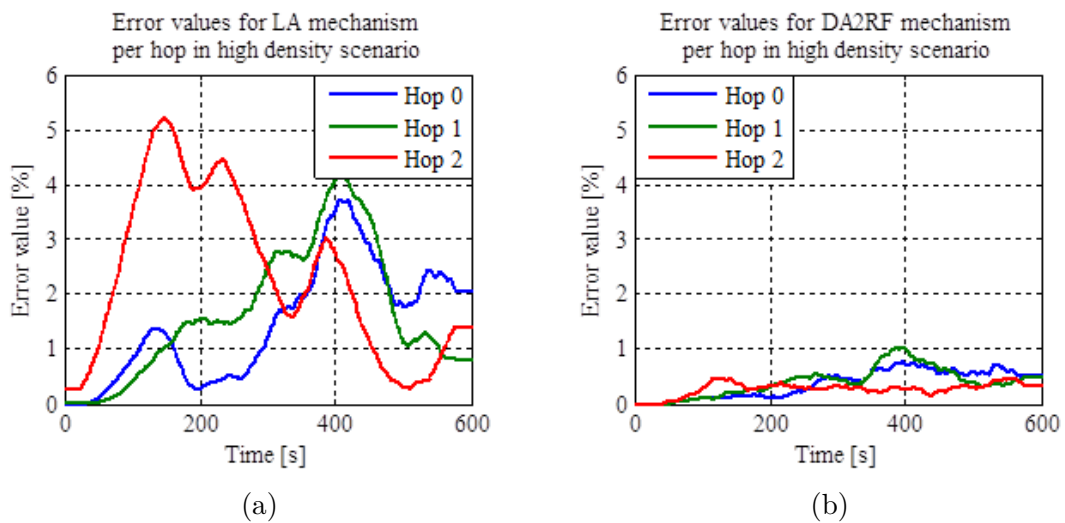

Figure 5.25: Per hop error values for the *LA* (a) and the *DA2RF* (b) mechanisms in high density scenario.

When the average error values are shown per hop, there is a slight trend that can be observed. The errors increase at the beginning of the simulation and then fluctuate until the end of simulation when they mostly decrease. Generally, Hop 2 has the largest average error whilst Hop 0 has the smallest. The error values of the *DA2RF* mechanism are smaller than the *LA* mechanism again due to significant broadcasting activity of the nodes in this scheme. On the other hand, the distribution of error values per hop in the *LA* mechanism is a direct consequence of the mobility of the vehicles and the levels of congestion on their routes. Based on the levels of congestion, the vehicles in the *LA* mechanism mostly refrained from broadcasting, which caused a slight increase of the errors. A slightly smaller value of error for Hop 0 than for Hop 1 and Hop 2 is due to the fact that vehicle's current street for which it was able to collect measurements on its own lies within Hop 0. Thus, the number of incoming measurements for the current street sections was always the same but the rest 11 slots (out of 12) in Hop 0 were filled differently, according to the received messages, hence the fluctuations in error values of Hop 0.

The previous results of error analysis showed the average error values dur-

ing the simulation through time. To get a better understanding of the overall performance of the error analysis, Figure 5.26 shows the mean values of the errors for the *LA* mechanism from previous figures, whilst the Figure 5.27 shows the mean values of the errors for the *DA2RF* mechanism. The figures show that the *LA* mechanism has the largest error in high density scenario. The reason for such a behaviour is the largest communication efficiency which is achieved in high density scenario where the reduction of broadcasting activity is the most significant. Still, overall results show that the *LA* mechanism keeps the average error below 3% whilst the *DA2RF* mechanism keeps it under 1% at the cost of approximately four times higher network load.

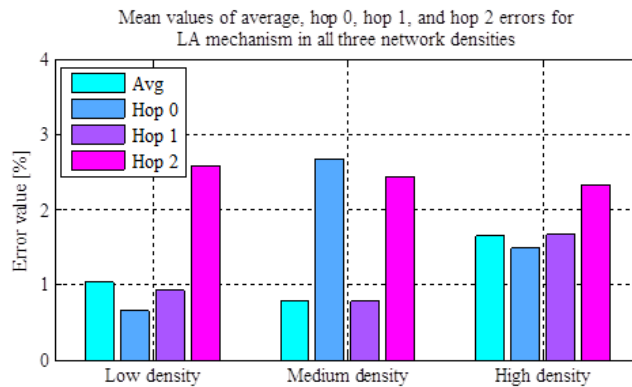

Figure 5.26: Mean values of all the errors recorded for the *LA* mechanism.

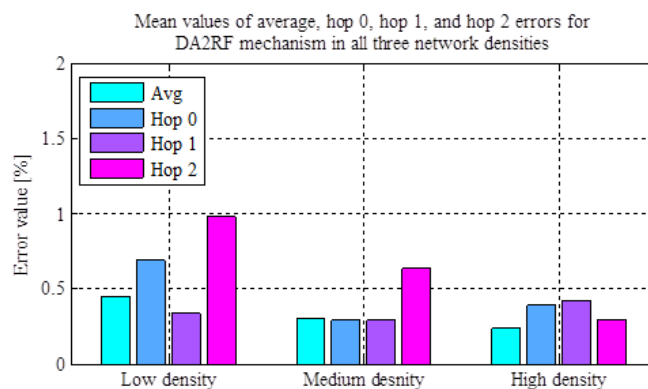

Figure 5.27: Mean values of all the errors recorded for the *DA2RF* mechanism.

The error analysis so far included average values for the entire database and average values per hop. Here we further break down the analysis into individual database slots, as shown in Figure 5.28. Figure 5.29, Figure 5.30 and Figure 5.31 show heat map of average errors per database slot, from Figure 5.28, in low, medium and high density of the *LA* mechanism, respectively. The purpose of following results is to show the average error value for each slot in the *World Model* of an average vehicle throughout the simulation.

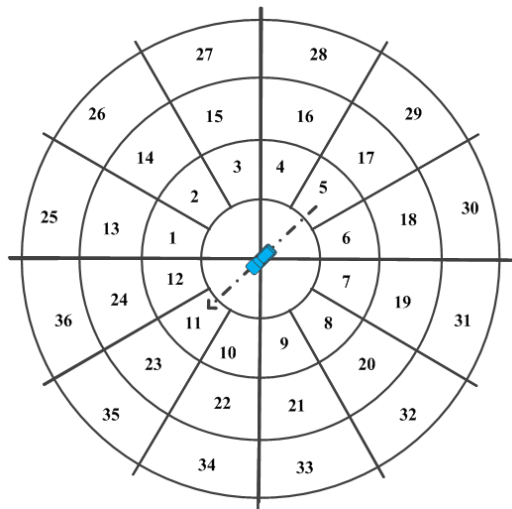

Figure 5.28: Representation of database slots.

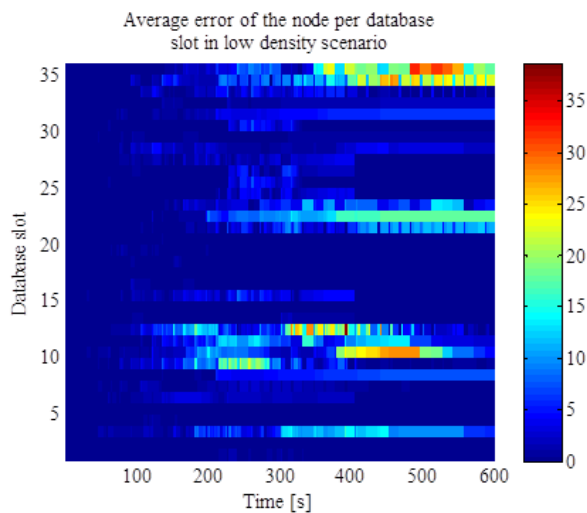

Figure 5.29: Average error values for the *LA* mechanism per database slot in low density scenario.

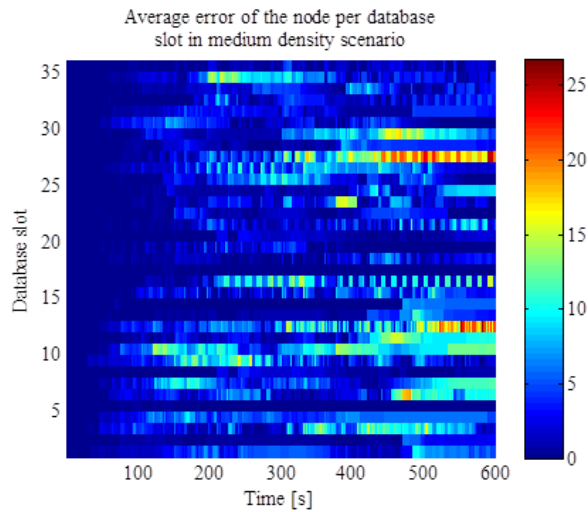

Figure 5.30: Average error values for the *LA* mechanism per database slot in medium density scenario.

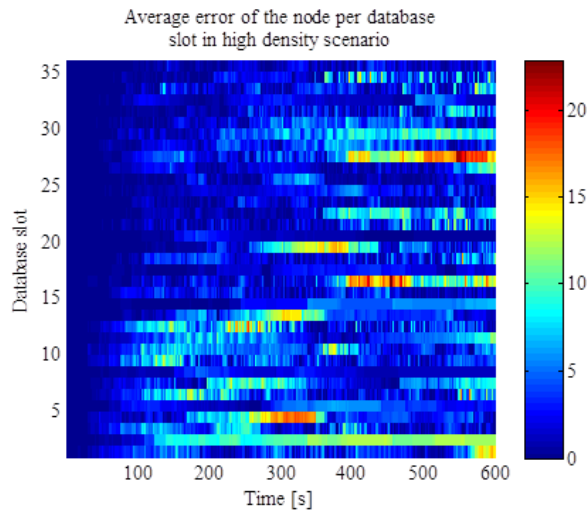

Figure 5.31: Average error values for the *LA* mechanism per database slot in high density scenario.

This analysis shows the average error in the vehicle's awareness about traffic congestion. Since the simulations are consisted of high number of nodes, we want to make sure that average vehicle does not have significantly compromised information during entire simulation. From the figures we can see that when using the *LA* mechanism vehicles are able to see the surrounding (represented by the 36 database slots) traffic congestion levels approximately the same way as when the *PB* mechanism is used. The average difference of the views achieved by the *LA* and *PB* mechanism from Figures 5.25, Figure 5.26 and Figure 5.27 is

controlled and mostly under 10% since most of all three heat maps are coloured in blue. There are also certain moments when error values suddenly rise and reach values of around 20% but these errors are occurring occasionally and are short-term. Furthermore, it can be seen that the errors, for example red, yellow and orange colours on figures, are constrained on a limited number of specific slots and are not scattered throughout the database. Again, the specific slots with the error depend on the mobility of the vehicles in the network.

To summarise the performance analysis, we conclude that the *LA* mechanism showed its excellent performance in reducing the network load and increasing the communication efficiency. The number of sent messages is reduced to approximately 25% on average of the sent messages in *PB* broadcasting. This further results in less contention activity of the nodes which is favourable for VANET scenarios in which nodes can use multiple applications simultaneously. The *LA* mechanism also ensures that message dissemination is achieved with low number of broadcasting nodes who are also able to achieve spatial efficiency as well. This means that the broadcasting activity per street segment is constrained and that average vehicle broadcasts less than one message per street segment which presents the clustering effect of the *LA* mechanism. The reduction in communication activity of the nodes results in slightly higher average error values than the *DA2RF* mechanism induces. The *DA2RF* had on average approximately more than three times higher number of sent messages than *LA* mechanism, which resulted in lower error values. The *LA* mechanism keeps the communication efficiency constrained and keeps the value of error controlled, on average lower than 10%. The error values were first observed from total average point of view where we evaluated average error in the entire *World Model*. The values of the errors in this case were limited to 3%. Then we separated the errors into hops to show the spatial distribution of the errors and found out that they are limited to 5%. Finally, we wanted to show the distribution of the errors inside the *World Model*

per individual slots. Such analysis showed the values during entire simulation are most of the time constrained with 10% and showed that there are some short-term occurrences when they reach 20%.

The aforementioned results show that achieving communication efficiency with controlled level of accuracy is achievable without using of GPS systems and digital maps. Performing the aggregation on flexible segmentation of the vehicle routes enables the vehicles to perform the aggregation while moving. The *LA* mechanism provides both clustering and adaptive broadcasting effect and ensures that vehicles are able to adjust their broadcasting activity according to the current level of some phenomenon from their current street segment. Operation of the *LA* mechanism is computationally simple and allows all incoming measurements to be fused and compared with existing information in the database. For these reasons and because of its generic nature, the *LA* mechanism can be used for efficient dissemination of any type of VANET information.

We conclude this chapter by analysing the *LA* mechanism according to the set of challenges introduced in Chapter 3 that represent important features of every data aggregation mechanism designed for VANETs. The analysis of the *LA* mechanism based on set of challenges is as follows:

- ***Challenge 1 (aggregation structure)***: The aggregation structure used by the *LA* mechanism is a flexible road segment determined by its direction  $\theta$ . Every segment that vehicle traversed is additionally characterised by its number  $i$ . Therefore, the vehicle using the *LA* mechanism does not require any pre-loaded maps and identification of road segments within a city area. The level of awareness provided by the *LA* mechanism depends on the requirements of the application. In this thesis the vehicle's awareness (*World Model*) was divided into 36 slots.
- ***Challenge 2 (aggregation function)***: The *LA* mechanism uses the

Kalman filter as an aggregation function. The Kalman filter fuses the incoming measurements as they arrive and provides an optimal estimations of the state, in this case the traffic congestion level, and values the latest information the most. By removing the uncertainty from the data the values in the *World Model* become less noisy and more suitable for trend monitoring.

- **Challenge 3 (message structure):** The size of the message in the *LA* mechanism is determined by the knowledge depth  $K$ . The message is consisted from  $K$  tuples of measurement value  $M$ , street direction  $\theta$ , and counter  $i$  of a street segment.
- **Challenge 4 (dissemination algorithm):** The dissemination process of the *LA* mechanism is based on decision making procedure described in Chapter 4. The broadcasting activity depends on the relationship of the level of congestion the vehicle observed on its own and a level of congestion the vehicle received from other vehicles about the same street section. The decision making process achieves a passive clustering and adaptive broadcasting effect which reduces the number of sent messages to 20% of the number sent by the *PB* mechanism.
- **Challenge 5 (penetration rate and density):** The *LA* mechanism does not require 100% penetration rate to be able to operate. Contrary to that, it is able to operate under various penetration rates or network densities. The evaluation and analysis of the *LA* mechanism showed that it is capable of working in low, medium and high density networks.
- **Challenge 6 (advanced technology):** One of the biggest advantages of the *LA* mechanism is that it does not require any advanced technology to be able to operate. Since it uses the direction of street segment as an aggregation structure there is no need for any additional navigation systems. Additionally, the simulation evaluation showed that the vehicle by using

the *LA* technique is capable of detecting approximately the same number of street segments as a vehicle using the GPS and digital maps.

- **Challenge 7 (*scenario type*):** The flexible segmentation provided by the *LA* technique can work well in both urban and highway environment and differentiates the observations coming from opposite directions.
- **Challenge 8 (*generic design*):** The *LA* mechanism is designed based on *Generic Modelling* approach and therefore it is not limited on use by a single application. Moreover, its design makes it applicable on simultaneous operation of multiple applications. This however, was not the focus of this research, thus we presented its operation on a case study application of traffic congestion detection and quantification.



# Chapter 6

## Conclusion

This thesis presented an intelligent, location-aware and generic data aggregation mechanism (*LA* mechanism) for real-time observation, estimation and efficient data dissemination in VANETs. The main contribution of the mechanism is the significant reduction of the communication overhead for a fully distributed VANET while providing accurate location awareness, even though the mechanism is based on the input from very basic and limited on-board vehicle systems. Unlike the existing data aggregation mechanisms, the proposed mechanism can be deployed in any type of vehicle with VANET communication capability, even without systems like navigation, digital maps or additional information from the roadside units or the local traffic authorities. The motivation for our work came from the need for efficient and scalable distributed protocols for the distribution of neighbourhood information using VANETs. The main aim of our solution is to use the data aggregation algorithms to increase scalability without compromising the accuracy of the communicated network information.

In the presented mechanism, location awareness is achieved using a simple direction parameter to create spatiotemporal database indexing for storing and sending messages in the network. Additionally, this enables the comparison of

aggregates and single observations which contributes to better accuracy. The database is being constantly refreshed, which solves the problem of old information in aggregates, thus providing only fresh information to the vehicle. The presented *Location Awareness* technique ensures that the database size is fixed and that it shows information about vehicle's nearest vicinity. Such approach enables the vehicles to become aware about their environment while moving and on the go. Since direction parameter is used as an aggregation structure, there is no need for unique identification of street segments. This is a major advantage, since the database is always of constant size and its maintenance is extremely efficient.

The mechanism is generic and messages can contain anything from traffic congestion information to accident location or free parking space information. This makes it applicable in any kind of application or even in multiple applications at the same time.

The use of the Kalman Filter is proposed as a fusion method for storing the incoming measurements. Such approach enables optimal estimation of the state of the observed phenomenon, in this case the traffic congestion level. Estimation based concept is perfectly tailored to the nature of VANETs, where nodes receive a large amount of messages about the variable congestion levels, which brings significant uncertainty into the process of calculating the real congestion level. Compared to the traditional data fusion approaches such as averaging, an estimation technique can handle the incoming measurements as they arrive. There is no need to wait for a certain number of measurements in order to calculate the average. The Kalman filter removes uncertainty from the received data and gives the possibility of describing the traffic related information as a system characterised by as many variables as needed, depending on the application design. Communication efficiency is achieved by intelligent passive clustering and an adaptive broadcasting based approach where individual vehicles intelligently

decide if and when the message should be broadcast to other vehicles in the network. The decision making process is based on vehicle's individual observation and their comparison with observations received from other vehicles. The scheme ensures the clustering effect by comparing the observations only with observations originating from the vehicle's current street segment. This way, the vehicles that detect the highest level of traffic congestion are responsible for broadcasting whilst the others will refrain and adaptation of broadcast interval is achieved. Such operation of the *LA* mechanism makes its broadcasting activity spatially efficient because it limits the number of broadcasting nodes per street segment.

The proposed mechanism was evaluated in complex simulations of urban environment and in different traffic densities, low, medium and high. The results showed the following:

- The *LA* mechanism showed that it can reduce the number of sent messages in the network to approximately 25% of the number of messages sent when periodic broadcasting is used. This results in overall reduction of network load and contributes towards alleviating the challenges of MAC layer of 802.11p, which have been questioned throughout the literature.
- The reduced communication activity in the network results in slight degradation in accuracy. However, the error values caused by the *LA* mechanism are limited and controlled and *LA* mechanism achieves good trade-off between communication efficiency and accuracy. The observed error values are shown for entire *World Model*, for *World Model* separated in hops and later separated in memory slots. All the observed errors are constrained within the 10% boundary, except in some short term episodes when they exceeded 20%.
- The spatial communication efficiency is achieved by limiting the broadcast activity per street segment showing the clustering effect without any

additional communication overhead as required with traditional clustering mechanisms with the cluster-head selection process.

- The *LA* mechanism provides the vehicles to communicate and perform data aggregation in real time without any major a priori assumptions, such as existence of GPS system and digital maps. The use of the Kalman filter provides optimal estimation of the congestion level by fusing the observations as they arrive without the need for an aggregation period.
- The *LA* mechanism is generic and applicable to any VANET application, whilst the results were obtained when traffic congestion quantification application is used.

# Chapter 7

## Publications and Future work

The research presented in this thesis together with its main contributions has been published in the following journal and conferences:

1. M. Milojevic, V. Rakocevic, "Location Aware Data Aggregation for Efficient Message Dissemination in Vehicular Ad Hoc Networks," IEEE Transactions on Vehicular Technology - Special Issue on Connected Vehicles, Vol.64, Issue 12, 2015.
2. M. Milojevic, V. Rakocevic, "Distributed Road Traffic Congestion Quantification Using Cooperative VANETs," 13th Annual Mediterranean Ad Hoc Networking Workshop, (IEEE MedHocNet '14).
3. M. Milojevic, V. Rakocevic, "Distributed Vehicular Traffic Congestion Detection Algorithm for Urban Environments," IEEE Vehicular Networking Conference (IEEE VNC '13).

In addition, the following papers that are not directly related to the research presented in this thesis but are based on VANETs and Veins simulation environment were published in cooperation with our colleagues:

1. K. Zaidi, M. Milojevic, V. Rakocevic, A. Nallanathan, M. Rajarajan, "Host Based Intrusion Detection for VANETs: A Statistical Approach to Rogue Node Detection," Accepted for publication on 12th August 2015 in IEEE Transactions on Vehicular Technology.
2. K. Zaidi, M. Milojevic, V. Rakocevic, M. Rajarajan, "Data Centric Rogue Node Detection in VANETs," 13th IEEE International Conference on Trust, Security and Privacy in Computing and Communications (IEEE Trust-Com'14).

The presented research makes a good foundation for the future research. Having in mind the generic design of the *LA* mechanism there are a number of ways to extend the research in data aggregation for VANETs:

- Leveraging the generic design of the *LA* mechanism further research can be performed to extend *LA* mechanism to support simultaneous operation of multiple applications. There is a need for the universal data aggregation mechanism design that can enable simultaneous operation of both periodic and event-driven applications. Apart for the dissemination of the traffic congestion level in the network, an extension of the *LA* mechanism could potentially be used for additional dissemination of emergency messages as well. Such solution can be designed by introducing the different levels of priority to distinguish various applications that are used by the vehicles at the same time. Unlike single-hop applications, event-driven applications are urgent and require new approach to broadcasting that is based on multi-hop communications and routing. In such communications the main challenge is to disseminate the messages with minimal latency (delay). The future research needs to focus on designing a sophisticated selection of forwarders based on locally available information and awareness of the environment. Further, the simultaneous co-existence of periodic and event-driven appli-

cations has rarely been considered by the authors in literature and there is a place for future research.

- Another direction for the future work based on this research is integration of security in VANETs using the *LA* mechanism. Security and privacy is another well-known challenge in VANETs, and design of universal data aggregation mechanism which is capable of preserving the node privacy is critical for future applications. Other than privacy in VANETs, the often discussed topic is detection of rogue nodes, thus the future research in this area could consider this aspect of security as well. Additional, direction can be the introduction of further cooperation among nodes and to extend *LA* mechanism by introducing the incentive for stimulating the cooperation. Having in mind that additional communication required for security mechanisms will induce more overhead, the future work needs to consider the impact of privacy preserving and security mechanisms on the communication efficiency and aforementioned operation with multiple simultaneous applications.
- This research presented *LA* mechanism and provided extensive evaluation via simulation. The next step in further evaluation that could lead to the potential improvements of the scheme would be experimental evaluation using testbeds. Such analysis could provide useful insight into operations of *LA* mechanism and could lead to potential optimisations.
- As a final direction for the future research based on this scheme we see further extension of the *LA* mechanism by incorporating precise SLAM techniques to enable the vehicles not only to have approximate awareness of their environment, but to enable them to build highly precise maps without existence of GPS. Such research would require thorough analysis of such models used in other scientific areas such as robotics.

# Bibliography

- [1] M. L. Sichitiu, M. Kihl, *"Inter-vehicle communication systems: a survey,"* IEEE Communications Surveys and Tutorials, Vol. 10, Issue 2, 2008.
- [2] *"IEEE Standard for Telecommunications and Information Exchange Between Systems – LAN/MAN Specific Requirements – Part 11: Wireless Medium Access Control (MAC) and physical layer (PHY) specifications: High Speed Physical Layer in the 5 GHz band,"* INSPEC Accession number 6596066, 1999.
- [3] *"802. 11p-2010-IEEE Standard for Information technology-Local and metropolitan area networks-Part 11: Wireless LAN Medium Access Control (MAC) and Physical Layer (PHY) Specifications Amendment 6: Wireless Access in Vehicular Environments,"* INSPEC Accession number 11908851, 2010.
- [4] S. Eichler, *"Performance evaluation of the 802.11p WAVE communication standard,"* 66th IEEE Vehicular Technology Conference, Fall 2007.
- [5] K. Bilstrup, E. Uhlemann, E. G. Strom, U. Bilstrup, *"On the ability of the 802.11p MAC method and STDMA to support real-time vehicle-to-vehicle communication,"* EURASIP Journal on Wireless Communications and Networking – Special Issue on wireless access in vehicular environments, 2009:902414, January 2009.



- [6] K. Bilstrup, E. Uhlemann, E. G. Strom, U. Bilstrup, "*Evaluation of the 802.11p MAC method for vehicle-to-vehicle communication*," 68th IEEE Vehicular Technology Conference, Fall 2008.
- [7] T. Kosch, C. J. Adler, S. Eichler, C. Schroth, "*The scalability problem of vehicular ad hoc networks and how to solve it*," IEEE Wireless Communications, October 2006, Issue 5, Vol 13.
- [8] S. Grafling, P. Mahonen, J. Riihijarvi, "*Performance evaluation of IEEE 1609 WAVE and IEEE 802.11p for vehicular communications*," Second International Conference on Ubiquitous and Future Networks (ICUFN), 2010.
- [9] H. Chong, M. Dianati, R. Tafazolli, R. Kernchen, "*Analytical study of the IEEE 802.11p MAC sublayer in vehicular networks*," IEEE Transactions on Intelligent Transportation Systems, Volume 13, Issue 2, 2013.
- [10] J. A. Fernandez, K. Borries, L. Cheng, B. V. K. V. Kumar, "*Performance of the 802.11p physical layer in vehicle-to-vehicle environments*," IEEE Transactions on Vehicular Technology, Volume 61, Issue 1, 2011.
- [11] J. R. Gallardo, D. Makrakis, H. T. Mouftah, "*Performance analysis of the EDCA medium access mechanism over the control channel of an IEEE 802.11p WAVE vehicular network*," IEEE International Conference on Communications (ICC), 2009.
- [12] Y. Wang, A. Ahmed, B. Krishnamachari, K. Psounis, "*IEEE 802.11p performance evaluation and protocol enhancement*," IEEE International Conference on Vehicular Electronics and Safety (ICVES), 2008.
- [13] A. Vinel, "*3GPP LTE versus IEEE 802.11p/WAVE: which technology is able to support cooperative vehicular safety applications?*," IEEE Wireless Communications Letters, Vol. 1, No. 2, 2012.

- [14] A. G. Ibanez, C. Flores, P. D. Reyes, A. Barba, "*A performance study of the 802.11p standard for vehicular applications*," 7th International Conference on Intelligent Environments (IE), 2011.
- [15] S. Dietzel, J. Petit, F. Kargl, B. Scheuermann, "*In-network aggregation for vehicular ad hoc networks*," IEEE Communication Surveys and Tutorials, Vol. 16, No. 4, 2014.
- [16] S. Zeadally, R. Hunt, Y. S. Chen, A. Irwin, A. Hassan, "*Vehicular ad hoc networks (VANETS): status, results, and challenges*," Telecommunication Systems, Vol. 50, Issue 4, 2012.
- [17] A. Willig, H. Karl, "*Protocols and architectures for wireless sensor networks*," Wiley 2005.
- [18] J. B. Kenney, "*Dedicated short-range communications (DSRC) standards in the United States*," Proceedings of the IEEE, Vol. 99, No. 7, July 2011.
- [19] M. L. Sichtiu, M. Kihl, "*Inter-vehicle communications systems: a survey*," IEEE Communications Surveys and Tutorials, Volume 10, No. 2, 2008.
- [20] S. Yousefi, M. S. Mousavi, M. Fathy, "*Vehicular ad hoc networks (VANETs): challenges and perspectives*," 6th International Conference on ITS Telecommunications, 2006.
- [21] H. Hartenstein, K. P. Labertaux, "*A tutorial survey on vehicular ad hoc networks*," IEEE Communications Magazine, Vol. 6, Issue 46, 2008.
- [22] G. Karagiannis, G. Altintas, O. Ekici, G. Heijenk, B. Jarupan, K. Lin, T. Weil, "*Vehicular networking: a survey and tutorial on requirements, architectures, challenges, standards and solutions*," IEEE Communications Surveys and Tutorials, Vol. 13, Issue 4, 2011.

- [23] M. J. Booyesen, S. Zeadally, G. J. van Rooyen, "*Survey of media access control protocols for vehicular ad hoc networks*," IET Communications, Vol. 5, Issue 11, 2011.
- [24] Y. Fan, S. Biswas, "*A self reorganizing MAC protocol for inter-vehicle data transfer applications in vehicular ad hoc networks*," 10th International Conference on Information Technology (ICIT), 2007.
- [25] B. Yuanguo, K. H. Liu, L. X. Cai, X. Shen, "*A multi-channel token ring protocol for QoS provisioning in inter-vehicle communications*," IEEE Transactions on Wireless Communications, Volume 8, Issue 11, 2009.
- [26] L. Ning, J. Yusheng, L. Fuqiang, W. Xinhong, "*A dedicated multi-channel MAC protocol design for VANET with adaptive broadcasting*," IEEE Wireless Communications and Networking Conference, 2010.
- [27] P. Jesus, C. Baquero, P. S. Almeida, "*A survey of distributed data aggregation algorithms*," IEEE Communications Surveys and Tutorials, Issue 1, Volume 17, 2015.
- [28] R. Rajagopalan, P. K. Varshney, "*Data-aggregation techniques in sensor networks: a survey*," IEEE Communications Surveys and Tutorials, Volume 8, Issue 4, 2006.
- [29] E. Fasolo, M. Rossi, J. Widmer, M. Zorzi, "*In-network aggregation techniques for wireless sensor networks: a survey*," IEEE Wireless Communications, Volume 14, Issue 2, 2007.
- [30] M. J. Handy, M. Haase, D. Timmermann, "*Low energy adaptive clustering hierarchy with deterministic cluster-head selection*," IEEE Conference on Mobile and wireless Communications Networks, 2002.

- [31] O. Younis, S. Fahmy, "*HEED: a hybrid, energy-efficient, distributed clustering approach for ad hoc sensor networks*," IEEE Transactions on Mobile Computing, Vol. 3, No. 4, 2004.
- [32] S. Chatterjea, P. Havinga, "*CLUDDA – clustered diffusion with dynamic data aggregation*," Cabernet Radicals Workshop, 2003.
- [33] S. Lindsey, C. S. Raghavendra, "*PEGASIS: power-efficient gathering in sensor information systems*," IEEE Aerospace Conference Proceedings, 2002.
- [34] M. Ding, X. Cheng, G. Xue, "*Aggregation tree construction in sensor networks*," 58th IEEE Vehicular Technology Conference, Fall 2003.
- [35] A. Boukerche, H. A. B. F. Oliveira, E. F. Nakamura, A. A. F. Loureiro, "*Vehicular ad hoc networks: a new challenge for localisation based systems*," Computer Communications, Volume 31, Issue 12, 2008.
- [36] W. Chen, W. L. Jin, A. Regan, "*Broadcasting safety information in vehicular networks: issues and approaches*," IEEE Network, Volume 24, Issue 1, January 2010.
- [37] G. R. Jagadeesh, T. Srikanthan, X. D. Zhang, "*A map matching method for GPS based real-time vehicle location*," The Journal of Navigation, Vol. 57, Issue 3, 2004.
- [38] T. King, H. Fußler, M. Transier, W. Effelsberg, "*Dead-reckoning for position-based forwarding on highways*," 3rd International Workshop on Intelligent Transportation (WIT), 2006.
- [39] H. L. Song, "*Automatic vehicle location in cellular communications systems*," IEEE Transactions on Vehicular Technology, Vol. 43, Issue 4, 1994.
- [40] A. Boukerche, H.A.B.F. Oliveira, E.F. Nakamura, A.A. Loureiro, "*Localization systems for wireless sensor networks*," IEEE Wireless Communications – Special Issue on Wireless Sensor Networks, Vol. 14, Issue 6, 2007.

- [41] T. Schmitt, R. Hanek, M. Beetz, S. Buck, B. Radig, "*Cooperative probabilistic state estimation for vision-based autonomous mobile robots*," IEEE Transactions on Robotics and Automation, Vol. 18, Issue 5, 2002.
- [42] E.F. Nakamura, A.A. Loureiro, A.C. Frery, "*Information fusion for wireless sensor networks: Methods, models, and classifications*," ACM Computing Surveys, Vol. 39, Issue 3, 2007.
- [43] *Tele Atlas (2016) 'Covent Garden, London'. Available at: <http://maps.google.co.uk>, Accessed: 03 January 2016.*
- [44] S. Dietzel, E. Schoch, B. Bako, F. Kargl, "*A fuzzy logic approach for structure-free aggregation in vehicular ad-hoc networks*," Proceedings of the sixth ACM international workshop on VehiculAr InterNETworking, VANET '09, 2009.
- [45] S. Dietzel, "*A structure-free aggregation framework for vehicular ad hoc networks*," 6th International Workshop on Intelligent Transportation, 2009.
- [46] A. N. Wisitpongphan, O. K. Tonguz, J. S. Parikh, P. Mudalige, F. Bai, V. Sadekar, "*Broadcast storm mitigation techniques in vehicular ad hoc networks*," IEEE Wireless Communications, Vol. 14 , Issue 6, 2007.
- [47] L. Wischhof, A. Ebner, H. Rohling, M. Lott R. Halfmann, "*SOTIS-a self-organizing traffic information system*," IEEE Vehicular Technology Conference 2003,VTC 2003-Spring.
- [48] T. Nadeem, S. Dashtinezhad, C. Liao, L. Iftode, "*TrafficView: a scalable traffic monitoring system*," IEEE International Conference on Mobile Data Management, 2004.
- [49] T. Nadeem, S. Dashtinezhad, C. Liao, L. Iftode, "*TrafficView: traffic data dissemination using car-to-car communication*," ACM Sigmobile Mobile Computing and Communications Review, Vol. 8, 2004.

- [50] C. Lochert, B. Scheuermann, M. Mauve, "*Probabilistic aggregation for data dissemination in VANETs*," Proceedings of the fourth ACM international workshop on Vehicular ad hoc networks VANET '07, USA 2007.
- [51] C. Lochert, B. Scheuermann, M. Mauve, "*A probabilistic method for cooperative hierarchical aggregation of data in VANETs*," Ad Hoc Networks, Vol. 8, Issue 5, 2010.
- [52] Y. Yuan, J. Luo, W. Yan, T. Zhao, "*DA2RF: A data aggregation algorithm by restricting forwarders for VANETs*," International Conference on Computing, Networking and Communications (ICNC), 2014.
- [53] K. Ibrahim, M. C. Weigle, "*CASCADE: cluster-based accurate syntactic compression of aggregated data in VANETs*," IEEE GLOBECOM Workshops, 2008.
- [54] B. Yu, C. Xu, M. Guo, "*Adapting forwarding delay control for VANET data aggregation*," IEEE Transactions on Parallel and Distributed Systems, Vol. 23, Issue 1, 2012.
- [55] B. Yu, J. Gong, C. Xu, "*Catch-up: a data aggregation scheme for vanets*," Proceedings of the fifth ACM international workshop on Vehicular Internetworking VANET '08, New York, NY, USA 2008.
- [56] C. L. Huang, Y. P. Fallah, R. Sengupta, H. Krishnan, "*Adaptive intervehicle communication control for cooperative safety systems*," IEEE Network, vol. 24, no. 1, pp. 6-13, 2010.
- [57] G. Bansal, J. B. Kenney, C. E. Rohrs, "*LIMERIC: A linear adaptive message rate algorithm for dsrc congestion control*," IEEE Transactions on Vehicular Technology, vol. 62, no. 9, pp. 4182–4197, Nov 2013.

- [58] C. Sommer, O. K. Tonguz, F. Dressler, "*Traffic information systems: efficient message dissemination via adaptive beaconing*," IEEE Communications Magazine, Vol. 49, Issue 5, 2011.
- [59] C. Shea, B. Hassanabadi, S. Valaee, "*Mobility-based clustering in VANETs using affinity propagation*," IEEE Global Telecommunications Conference (GLOBECOM), 2009.
- [60] S. S. Wang, Y. S. Lin, "*Performance evaluation of passive clustering based techniques for inter-vehicle communications*," 19th International IEEE Wireless and Optical Communications Conference (WOCC), 2010.
- [61] S. S. Wang, Y. S. Lin, "*PassCAR: a passive clustering aided routing protocol for vehicular ad hoc networks*," Computer Communications, Vol. 36, Number 2, 2013.
- [62] S. Dietzel, F. Kargl, G. Heijenk, F. Schaub, "*On the potential of generic modeling for VANET data aggregation protocols*," IEEE Vehicular Networking Conference, 2010.
- [63] S. Dietzel, F. Kargl, G. Heijenk, F. Schaub, "*Modeling in-network aggregation in VANETs*," IEEE Communications Magazine, Vol. 49, Issue 11, 2011.
- [64] R. Vincent, B. Limketkai, M. Eriksen, "*Comparison of indoor robot localization techniques in the absence of GPS*," Proceedings Detection and Sensing of Mines, Explosive Objects, and Obscured Targets, Vol. 7664, 2010.
- [65] H. Durrant-Whyte, T. Bailey, "*Simultaneous localization and mapping: part I*," IEEE Robotics & Automation Magazine, Vol. 13, Issue 2, 2006.
- [66] T. Bailey, Tim, H. Durrant-Whyte, "*Simultaneous localization and mapping (SLAM): Part II*," IEEE Robotics & Automation Magazine, Vol.13, Issue 3, 2006.

- [67] E. F. Nakamura, "*Information fusion for wireless sensor networks: methods, models and classifications*," ACM Computing Surveys, Vol. 39, No. 3, 2007.
- [68] M. Milojevic, V. Rakocevic, "*Distributed road traffic congestion quantification using cooperative VANETs*," IEEE Mediterranean Ad Hoc Networking Workshop, 2014.
- [69] M. Milojevic, V. Rakocevic, "*Short paper: distributed vehicular traffic congestion detection algorithm for urban environments*," IEEE Vehicular Networking Conference, 2013.
- [70] B. Khaleghi, A. Khamis, F. O. Karray, S. N. Razavi, "*Multisensor data fusion: a review of state of the art*," Information Fusion, 14(1), 28-44, 2013.
- [71] R. E. Kalman, "*A new approach to linear filtering and prediction problems*," J. Basic Eng., Vol.82, No.1, March 1960.
- [72] S. Vodopivec, J. Bešter, A. Kos, "*A survey on clustering algorithms for vehicular ad-hoc networks*," 35th IEEE International Conference on Telecommunications and Signal Processing (TSP), 2012.
- [73] C. Sommer, Z. Yao, R. German, F. Dressler, "*On the need for bidirectional coupling of road traffic microsimulation and network simulation*," 1st ACM SIGMOBILE workshop on Mobility models, 2008.
- [74] C. Sommer, Z. Yao, R. German, F. Dressler, "*Simulating the influence of IVC on road traffic using bidirectionally coupled simulators*," INFOCOM Workshops, 2008.
- [75] C. Sommer, R. German, F. Dressler, "*Bidirectionally coupled network and road traffic simulation for improved IVC analysis*," IEEE Transactions on Mobile Computing, Vol. 10, Issue 1, 2011.



- [76] C. Bettstetter, "*Topology properties of ad hoc networks with random waypoint mobility*," ACM International Symposium Mobile Ad Hoc on Networking and Computing (MobiHoc), Poster session, 2003.
- [77] C. Lochert, A. Barthels, A. Cervantes, M. Mauve, M. Caliskan, "*Multiple simulator interlinking environment for IVC*," 2nd ACM International Workshop Vehicular Ad hoc Networks (VANET), 2005.
- [78] A. Varga, "*The OMNeT++ Discrete Event Simulation System*," Proc. European Simulation Multiconf. (ESM '01), 2001.
- [79] D. Krajzewicz, J. Erdmann, M. Behrisch, L. Bieker, "*Recent Development and Applications of SUMO - Simulation of Urban Mobility*," International Journal On Advances in Systems and Measurements, Vol. 5, Issue 3 & 4, 2012.
- [80] *Mixim.sourceforge.net: MiXiM simulator for wireless and mobile networks using OMNeT++.*
- [81] A. Wegener, M. Piorkowski, M. Raya, H. Hellbruck, S. Fischer, J.P. Hubaux, "*TraCI: An Interface for Coupling Road Traffic and Network Simulators*," 11th Communications and Networking Simulation Symposium (CNS), 2008.
- [82] *Veins simulator architecture. Available at: <http://veins.car2x.org/>, Accessed: 10 January 2016.*
- [83] K. Nagel, M. Schreckenberg, "*A Cellular Automaton Model for Freeway Traffic*," J. Physique I France, 1992.
- [84] S. Krauß, "*Microscopic Modeling of Traffic Flow: Investigation of Collision Free Vehicle Dynamics*," PhD thesis, University of Cologne, 1998.
- [85] E. Brockfeld, P. Wagner, "*Testing and Benchmarking of Microscopic Traffic Flow Simulation Models*," 10th World Conference Transport Research (WCTR), 2004.

- [86] *"Openstreetmp.org: OpenStreetMap is built by a community of mappers that contribute and maintain data about roads, trails, cafés, railway stations, and much more, all over the world."*
- [87] M. Baguena, S. M. Tornell, A. Torres, C. T. Calafate, *"VACaMobil: VANET car mobility manager for OMNeT++,"* IEEE International Conference on Communications Workshops (ICC), 2013.