



City Research Online

City, University of London Institutional Repository

Citation: Ucur, M., Divall, S., Stallebrass, S. E., Taylor, N., Davies, M. C. R. & McNamara, A. M. (2024). Development of apparatus of modelling a "shaft break-out" in clay. Paper presented at the 5th European Conference on Physical Modelling in Geotechnics (ECPMG 2024), 2-4 Oct 2024, Delft, Netherlands.

This is the published version of the paper.

This version of the publication may differ from the final published version.

Permanent repository link: <https://openaccess.city.ac.uk/id/eprint/33199/>

Link to published version:

Copyright: City Research Online aims to make research outputs of City, University of London available to a wider audience. Copyright and Moral Rights remain with the author(s) and/or copyright holders. URLs from City Research Online may be freely distributed and linked to.

Reuse: Copies of full items can be used for personal research or study, educational, or not-for-profit purposes without prior permission or charge. Provided that the authors, title and full bibliographic details are credited, a hyperlink and/or URL is given for the original metadata page and the content is not changed in any way.

City Research Online:

<http://openaccess.city.ac.uk/>

publications@city.ac.uk

Development of apparatus for modelling a “shaft break-out” in clay

M. Ucur

Department of Engineering, City, University of London, London, UK, mayda.ucur@city.ac.uk

S. Divall, S.E. Stallebrass, R.N. Taylor, M.C.R. Davies, A.M. McNamara

Department of Engineering, City, University of London, London, UK

sam.divall@city.ac.uk, s.e.stallebrass@city.ac.uk, r.n.taylor@city.ac.uk, michael.davies@city.ac.uk, a.mcnamara@city.ac.uk

ABSTRACT: Shafts can have multiple uses including providing the access to underground-level tunnels or forming new sections of permanent works. The construction process often used to create the connection between a shaft and a tunnel is known as “shaft breakout”. This construction process involves the formation of an opening, disturbing the loading and supporting equilibrium of the shaft. Currently, there is limited published knowledge about the behaviour of the shaft lining and the ground adjacent to the opening during the breakout. This results in conservative design approaches and substantial temporary works. Insight into this complex underground construction process can be obtained by using geotechnical centrifuge modelling techniques. This paper details the design of a novel shaft breakout model that will be used to provide data on the short-term structural behaviour of a shaft during the formation of an opening in a parametric study. The model will consist of a preformed instrumented circular liner with a removable opening that will be situated within a Speswhite kaolin clay sample.

1 INTRODUCTION

There is an increasing demand for underground infrastructure owing to the ongoing growth of the urban population and the limited surface space available. The development of underground infrastructure aims to eliminate the burden on urban transportation and systems (such as water management) in major cities.

Shafts are incorporated in numerous underground infrastructure projects for level access, ventilation and material transportation. Shafts in clay were typically constructed using cast iron rings, however recently a range of methods are used including precast concrete segments, sprayed concrete and caissons (Faustin et al, 2018). Lateral openings (“shaft break-outs”) can be introduced in vertical shafts for the construction of shaft-to-tunnel connections and these openings vary in size depending on the purpose of the shaft or tunnel. A conservative opening size of one-third of the shaft diameter would normally be considered standard though there is currently no published guidance providing an agreed standard on the design or relative opening size. Recent research (Challinor, 2022) identifies the most detailed guidance published by the British Tunnelling Society Tunnel Design (The British Tunnel Society 2004), which highlights the lack of understanding during the design stage. However, there

is general agreement that the connection of a tunnel and a shaft or other underground structure can be considered as a critical operation due to the stability of the structure and ground.

2 PREVIOUS WORK

Over recent years there has been a number of analytical experimental and field of lateral openings in tunnels analysing the distribution of the stresses around the opening and determining adequate support systems (Lee et al, 2017). Both finite element analyses and geotechnical centrifuge modelling have been used to analyse openings in tunnels. Spyridis et al. (2015) investigate the response of the tunnel opening using 2D and 3D finite element analyses. The paper concludes that the opening size and the soil stiffness have a strong influence on the redistribution of the stresses after the completion of the opening.

Field measurements have been compared with finite analysis models to investigate the stresses acting around segmental tunnels with an opening constructed with a tunnel boring machine (Lee et al., 2017). The authors concluded that the opening segments, in the 3D model, were subjected to a higher range of deformation than the field data indicated, however, still within an acceptable range.

A model tunnel with three openings was modelled using geotechnical centrifuge testing techniques by Lu et al. (2022). The study investigated the mechanical characteristics of shield tunnels with a range of opening shapes and sizes. It concluded that the size of the opening influenced the behaviour of the tunnel, specifically the larger the opening, the larger the concentration of the stresses close to the opening.

Therefore, significant insight could be gained from similar investigations into the behaviour of a shaft liner using the process of “shaft break-out“.

3 TEST DESIGN

3.1 Soil sample

The soil sample to be used in this project will be created by initially producing a slurry, which would be placed in a circular container, with diameter of 420mm (known hereafter as a tub), and subjected to a vertical stress that will result in a desirable undrained shear strength. The first tests will make use of a soft clay sample having been subjected vertical stress of 180kPa, and prior to the model making. This desired stress history will allow for the soil failure during the construction phase but also sufficiently strong to allow adequate model making procedures to take place.

3.2 Model lining

The model lining, Figure 1, is formed from an aluminium tube with the Young’s modulus of the material of 69GPa. The dimensions of the model lining consist of 101.6mm outer diameter with a thickness of 1.6mm and a depth of 254mm. An opening with a 34mm diameter, limited to one-third of the shaft outer diameter, is cut into the aluminium tube 218mm from the top of the shaft to the centre of the opening.

The model test will be conducted at 118 times Earth’s gravity ($n = 118$), using the scaling law for bending stiffness (EI) the prototype thickness is equivalent to 300mm. The equations presented in previous works (Taylor, 1994) indicate the represented prototype thickness can be obtained using:

$$t_p = \frac{n}{\left(\frac{E_p}{E_m}\right)^{1/3}} t_m \quad (1)$$

Where n is the scaling variable, $t_m(t_p)$ is the model (prototype) shaft lining thickness and $E_m(E_p)$ is the elastic modulus of the model (prototype) material. Therefore, the model lining has been

represents a continuous concrete lining, the Young’s modulus of material of the lining is 30GPa. The envisaged prototype shaft has a 12m outer diameter cylinder, and a constructed depth of 30m.

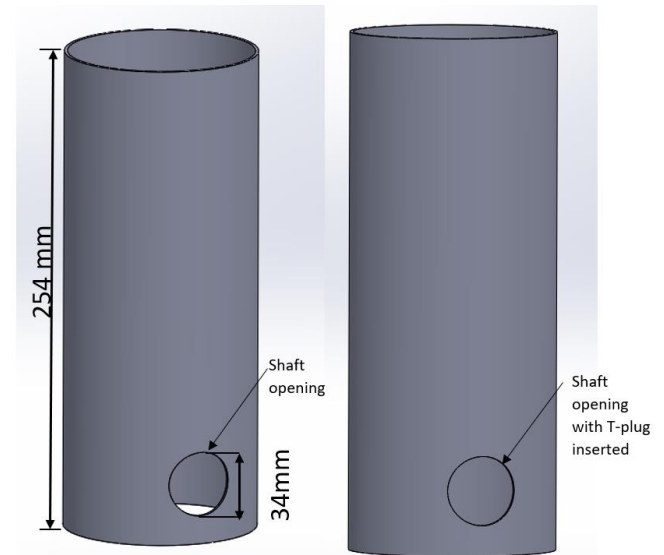

Figure 1 Shaft lining with opening

3.3 Breakout mechanism

A curved plug, see Figure 2, has been designed to seal the opening and represent a uniform lining as the model is brought to hydrostatic equilibrium at 118 times Earth’s gravity. The design of the plug has been driven by the stress acting on the plug from the surrounding soil, the thickness of the plug being determined by calculating the bending moment acting on the plug to ensure the plug does not deflect or buckle. Since the stress acting at the top and the bottom of the opening varies with depth, the plug has been designed using the stress acting at a depth equivalent to the mid-point of the opening. The plug was 3D printed using a micro carbon fibre-filled nylon material known as onyx plastic with a groove offset from the top of the flange to inset an O-ring. The O-ring will be compressed between the plug and the aluminium tube to ensure a watertight seal.

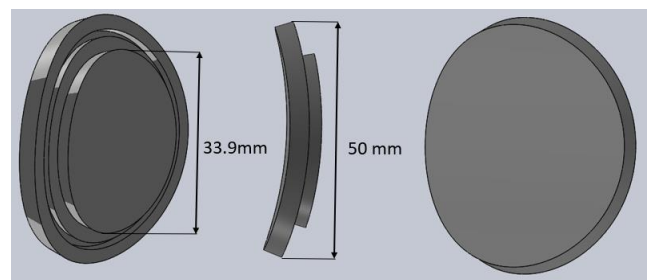

Figure 2: render of the curved plug

A toroid shaped latex bag (Figure 3) has also been designed to function as an internal support

mechanism to resist the stress acting on the plug from the soil (and hold the plug in place in the wall of the cylinder). A self-stressing reaction frame has been designed to contain the latex bag to ensure pressure is only applied in the radial direction. The latex bag has been designed to be supplied with pressurised air to achieve this action.

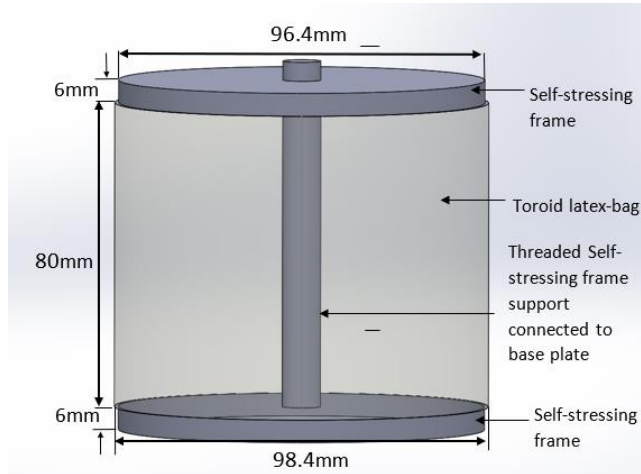

Figure 3: Self-stressing frame and toroid latex bag.

4 MODEL TESTING

The model shaft will be placed in a tub that has a diameter of 420mm with a depth of 295mm. Once a soil sample has been fully consolidated it will be removed from the hydraulic press and the model shaft assembled by installing the cylinder in a pre-bored cavity, as shown in Figure 4. The model will be instrumented with displacement transducers - monitoring settlement of the soil and vertical movement of the cylinder - and pore-pressure transducers located at different radii from the cylinder at the depth of the centre of the opening.

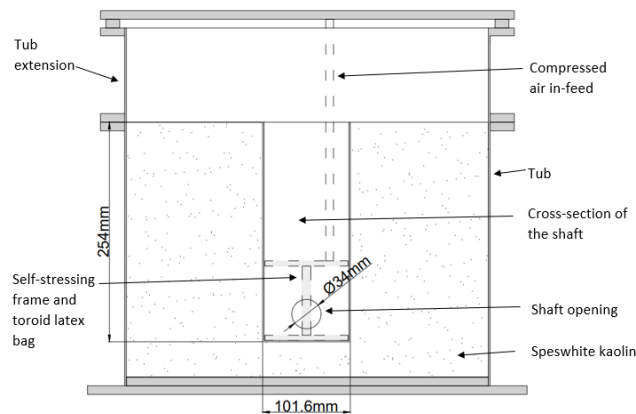

Figure 4: schematic cross-section of model.

The shaft will be instrumented with strain gauges that will allow axial and radial strains in the cylinder to be monitored during and following the removal of the plug. From these measurements it will be possible to calculate changes in radial stress, axial stress, and the development of bending moments in the wall of the shaft. In particular, the instrumentation will be concentrated around the opening.

Before installing the shaft, the curved plug will be inserted into the opening to ensure it is both watertight and acting as a continuous shaft. To ensure the soil does not fail during the acceleration of the centrifuge the latex bag will be supplied with compressed air at a pressure corresponding to the overburden stress at the axis level of the opening.

Once the model reaches its hydrostatic equilibrium the compressed air will be released at 1kPa per second to simulate the shaft breakout construction process.

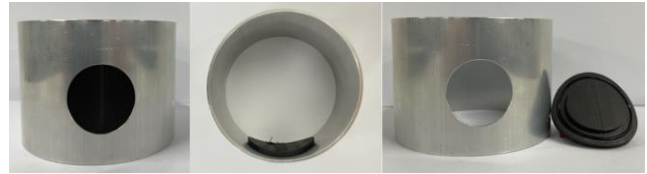

Figure 5: Trial of the lower part of the shaft showing the curved plug arrangement.

5 CONCLUSION/FURTHER RECOMMENDATIONS

To investigate the break-out from a shaft in clay a series of geotechnical centrifuge model tests are to be conducted. This paper describes the design of the apparatus to be used for this investigation.

The parametric study conducted using this apparatus will consist of investigating the shaft behaviour with three sizes of opening. This study will be further expanded by investigating the structural behaviour in centrifuge model tests with the openings located at various depths.

ACKNOWLEDGEMENTS

The authors are grateful for the support provided by COWI, Joseph Gallagher Ltd and the School of Science & Technology at City, University of London.

REFERENCES

- Challinor, P. (2022). Openings in shafts (in London Clay). MSc Dissertation, City, University of London, London, UK.

- Faustin, N.E., Elshafie, M.Z. and Mair, R.J., (2018). Case studies of circular shaft construction in London. *Proceedings of the Institution of Civil Engineers-Geotechnical Engineering*, 171(5), pp.391-404.
- Lee, T.H. and Choi, T.C., (2017). Numerical analysis of cross passage opening for TBM tunnels. In *Proceedings of the 19th international conference on soil mechanics and geotechnical engineering, Seoul* (pp. 1713-1719).
- Lu, P., Yuan, D., Luo, W., Jin, D. and Liu, M., (2022). Centrifugal Model Test Study on the Mechanical Characteristics of Shield Tunnels Influenced by Different Types of Openings for Cross Passages. *Applied Sciences*, 12(13), p.6421.
- Spyridis, P. and Bergmeister, K., (2015). Analysis of lateral openings in tunnel linings. *Tunnelling and Underground Space Technology*, 50, pp.376-395.
- Taylor, RN ed, ed. *Geotechnical centrifuge technology*. CRC Press, 2018.
- The British Tunnelling Society (2004) *Tunnel Lining Design Guide*