



# City Research Online

## City, University of London Institutional Repository

---

**Citation:** Trozzi, V., Gentile, G., Kaparias, I. and Bell, M. G. H. (2015). Effects of countdown displays in public transport route choice under severe overcrowding. *Networks and Spatial Economics*, 15(3), pp. 823-842. doi: 10.1007/s11067-013-9207-5

This is the accepted version of the paper.

This version of the publication may differ from the final published version.

---

**Permanent repository link:** <http://openaccess.city.ac.uk/13051/>

**Link to published version:** <http://dx.doi.org/10.1007/s11067-013-9207-5>

**Copyright and reuse:** City Research Online aims to make research outputs of City, University of London available to a wider audience. Copyright and Moral Rights remain with the author(s) and/or copyright holders. URLs from City Research Online may be freely distributed and linked to.

---

City Research Online:

<http://openaccess.city.ac.uk/>

[publications@city.ac.uk](mailto:publications@city.ac.uk)

---

Submission to the DTA2012 Special Issue:

1  
2  
3  
4  
5  
6  
7  
8  
9  
10  
11  
12  
13  
14  
15  
16  
17  
18  
19  
20  
21  
22  
23  
24  
25  
26  
27  
28  
29  
30  
31  
32  
33  
34  
35  
36  
37  
38  
39  
40  
41  
42  
43  
44  
45  
46  
47  
48  
49  
50  
51  
52  
53  
54  
55  
56  
57  
58  
59  
60  
61  
62  
63  
64  
65

# Effects of countdown displays in public transport route choice under severe overcrowding.

Corresponding Author: Ms Valentina Trozzi,  
[ValentinaTrozzi@tfl.gov.uk](mailto:ValentinaTrozzi@tfl.gov.uk)  
044(0)20  
*Transport Planning – London Underground.*  
55 Broadway, London SW1H 0BD (UK)

Prof Guido Gentile,  
*Università di Roma “La Sapienza”*  
Via Eudossiana 18, 00184 Roma (Italy)

Dr Ioannis Kaparias,  
*City University London*  
Northampton Square, London EC1V 0HB (UK)

Prof Michael G. H. Bell  
*Sydney University*  
Newtown Campus, The University of Sydney, NSW 2006 (Australia)

## ABSTRACT

The paper presents a route choice model for dynamic assignment in congested, i.e. overcrowded, transit networks where it is assumed that passengers are supported with real-time information on carrier arrivals at stops. If the stop layout is such that passenger congestion results in First-In-First-Out (FIFO) queues, a new formulation is devised for calculating waiting times, total travel times and route splits. Numerical results for a simple example network show the effect of information on route choice when heavy congestion is observed. While the provision of information does not lead to a remarkable decrease in total travel time, with the exception of some particular instances, it changes the travel behaviour of passengers that seem to be more averse to queuing at later stages of their journey and, thus, prefer to interchange at less congested stations.

## KEYWORDS

Public Transport; Dynamic Assignment; Online Information; Passengers' queues.

# Effects of countdown displays in public transport route choice under severe overcrowding.

## 1 INTRODUCTION

It has been largely acknowledged in the last decades that urban sustainable development needs to overcome the dependence on the private car (Newman and Kenworthy, 1999, European Commission, 2009) and requires a modal shift towards public transport, as it performs better than private transport with regard to the six sub-objectives for sustainability developed by May in 2001 (unpublished, cited by Black *et al.*, 2002). In this context, much hope is invested in Advanced Traveller Information Systems (ATIS). Indeed, although information provision cannot directly decrease private car use, it can produce time savings – either when tracking and comparing travel options or when planning and deciding – and thus can enhance the quality of service, which in turn contributes to persuading people to switch modes.

In order to evaluate the potential benefit brought about by ATIS in terms of total travel time savings and congestion relief on the public transport network, new route choice models for transit assignment are needed, which are capable of representing the travel choices of passengers assisted by information systems and highlight any change in the distribution of flows across the network with respect to the case where no ATIS is in place, especially if the system is subject to recurring overcrowding.

Consequently, this paper proposes a dynamic route choice model for transit assignment to densely connected networks where congestion results in passengers First-In-First-Out (FIFO) queues at the stops and where travellers are supported with real-time information on vehicle arrivals, for example through countdown displays.

In densely connected urban networks, following Nguyen and Pallottino (1988) and Spiess and Florian (1989), it is assumed that passengers would not select the shortest single itinerary to destination, but would rather choose a bundle of potentially optimal paths, formally known as *hyperpaths* or *travel strategies*, and then would follow one specific path of their hyperpath depending on events occurring while they are waiting at the stop, namely what is the first *attractive line* (Nguyen and Pallottino, 1988) that they can board.

Moreover, as in (Hickman and Wilson, 1995, Gentile *et al.*, 2005), it is assumed that real-time information changes the travel behaviour in such a way that travellers would not get on a carrier only because it is the first of their choice set that becomes available at the stop, but would board it

1 only if its remaining travel time to destination is shorter than the sum of waiting time plus travel  
2 time upon boarding for subsequent services. An important innovation with respect to (Hickman  
3 and Wilson, 1995, Gentile *et al.*, 2005) is that the proposed model acknowledges that recurrent  
4 overcrowding can result in passengers' queues at transit stops and, in the context of commuting  
5 trips, it is assumed that travellers do not make their travel choices only considering the average  
6 values of frequencies and in-vehicle travel times, but also considering congestion levels for the  
7 different lines of their choices. In other words the proposed model assumes that the users know by  
8 previous travel experience how many vehicles of the same line they have to wait, on average,  
9 because of insufficient capacity on-board.

10 First applications to a small example network seem to suggest that, if real time information is  
11 provided, route choices tend to be more conscious in the sense that passengers would be more  
12 prone to wait for a subsequent service or select slower lines in order to avoid transfers at crowded  
13 stations.

14 The rest of the paper is organised as follows. The next section presents the background of the  
15 study, while the methodology is explained in Section 3. The solution algorithm is detailed in  
16 Section 4. Finally, in Section 5 a numerical example is presented and conclusions are drawn in  
17 Section 6.

## 27 **2 BACKGROUND**

28 Transit assignment aims at describing and predicting the choices of public transport users,  
29 depending on the assumptions made about travellers' behaviour, congestion effects, and the level  
30 of service supplied by the transport system.

31 For example, in networks with highly frequent services it is assumed that travellers do not time  
32 their arrival at stops with the lines' schedule and, when making their travel choices, they only  
33 consider average frequencies and in-vehicle travel times (this is the main assumption of frequency-  
34 based models). In such a setting, transit assignment models can be developed considering a  
35 *strategy-based* (or *hyperpath-based*) route choice model, as in (Spiess and Florian, 1989). Starting  
36 from the origin, the travel strategy involves the iterative sequence of walking to a public transport  
37 stop or to the destination, selecting the set of *attractive lines* (Nguyen and Pallottino, 1988) to  
38 board and, for each of them, the stop where to alight. If two or more attractive lines are available at  
39 the origin/transfer stop, then the best option is to board the first one approaching (Spiess, 1983,  
40 Spiess, 1984).

41 The result of such a choice is a set of simple itineraries that can diverge, only at stops, along the  
42 routes of the attractive lines (Bouzaiene-Ayari *et al.*, 2001), and the realisation of the same travel  
43 strategy may change, from day to day, due to 'micro-level' events such as what attractive line  
44 becomes available first at the stop, or what is the actual realisation of the waiting and in-vehicle  
45 time. Notwithstanding these uncertainties on the supply and the stochasticity of the waiting time,  
46 the classical application of the hyperpath paradigm allows for developing a *deterministic* route  
47 choice model for transit assignment, where it is assumed that travel choices ultimately depend on  
48

1 the expected value of the total travel time and not on its actual realisation on a particular day.  
2 Despite some authors (Miller-Hooks and Mahmassani, 2000, Pretolani 2000, Yang and Miller-  
3 Hooks, 2004) have also applied hyperpaths to model explicitly the effect of day-to-day variations  
4 of travel times on route choice and on its en-trip adaptations, such extensions are not considered  
5 here, while the original formulation of travel strategies for deterministic route choice in networks  
6 with uncertainties is.  
7

8 Furthermore, when the usual assumptions that no congestion occurs, and that the only information  
9 available to passengers is what line arrives first, do not hold true, the traditional strategy-based  
10 assignment models are not suitable to represent the behaviour of passengers that travel in densely  
11 connected transit networks. Consequently in the last two decades many works have been proposed  
12 to investigate either the effect of passenger queues at the stop or the effect of countdown displays,  
13 while the combination of the two problems has't been largely investigated yet.  
14  
15  
16  
17  
18

## 19 **2.1 Congestion and capacity constraints**

20 While recurring passenger congestion is one of the main problems faced by large-city transit  
21 networks, in the literature there does not seem to be any broad agreement on how this phenomenon  
22 should be modelled.  
23

24 The vast majority of research works carried out in this context focuses on static transit assignment  
25 and the effects of overcrowding are modelled by means of the *effective frequency*, with or without  
26 capacity constraints (De Cea and Fernandez, 1993, Cominetti and Correa, 2001, Cepeda *et al.*,  
27 2006), *fail-to-board probability* (Kurauchi *et al.*, 2003), *attractivity threshold* (Leurent and  
28 Benezech, 2011), or by micro-simulation (Teklu, 2008).  
29

30 However, even when capacity constraints are considered, static models can only yield average  
31 results (in terms of flows and travel time estimation) for the entire analysis period, and cannot  
32 reproduce the formation and dispersion of passenger queues at stops nor their dynamic effects on  
33 route choice. This drawback is partially overcome by Schmöcker *et al.* (2008), who develop a  
34 *quasi-dynamic* strategy based assignment that reproduces dynamic variations in the Level of  
35 Service (LoS) caused by passenger congestion. On the other hand, while in their route choice  
36 model it is assumed that the anticipated value of delays increases the expected total travel time to  
37 destination, the effect of congestion on passengers' distribution among attractive lines is  
38 disregarded.  
39

40 Additionally, the majority of strategy-based assignment models assume that, if travel demand  
41 exceeds the supplied capacity, queuing passengers do not respect any boarding priority. The  
42 assumption is usually accepted when modelling passenger flows in rail and/or underground  
43 networks because large platforms allow travellers to mingle and, thus, it is thought that who arrives  
44 last might be 'lucky' and board the first approaching carrier despite congestion, while other  
45 passengers can be 'unlucky' and keep waiting even if they arrived before. However, when  
46 overcrowding is very severe the priority of those who are closer to the edge of the platform is  
47 usually respected and, thus, a model based on a First-In-First-Out (FIFO) queuing mechanism  
48 would seem more appropriate. Additionally, for bus systems (where boarding is generally allowed  
49  
50  
51  
52  
53  
54  
55  
56  
57  
58  
59  
60  
61  
62  
63  
64  
65

only from front doors) the stop layout is usually designed to allow passengers queuing in a FIFO fashion.

Unfortunately, models based on the FIFO queuing assumption have proved to be very complex to develop and, to the best of the authors' knowledge, all existing attempts (Gendreau, 1984, Bouzaïene-Ayari, 1988, Bouzaïene-Ayari *et al.*, 2001, Leurent and Benezech, 2011) share the *stability condition* (passengers waiting at a stop would consider an attractive set that is never completely saturated, in the sense that, at least for one of the attractive lines, passengers can board the first vehicle coming, Bouzaïene-Ayari *et al.*, 2001) which implies the following two shortcomings:

- as congestion increases, more (and hence 'worse') lines are included in the attractive set; and
- if all lines are congested, passengers would rather walk than keep waiting (even if frequencies are high, so that the extra waiting time due to congestion is, anyhow, short).

A schedule-based approach has also been applied by some authors (Hamdouch and Lawphongpanich, 2008, Hamdouch *et al.*, 2011), who have extended an existing dynamic strategy-based model for traffic assignment with time-expanded network (Hamdouch *et al.*, 2004) to public transport systems. This approach has the advantage that the dynamic assignment reduces to a static assignment on the time-expanded network and, in this setting, it is possible to accurately represent the build-up and dissipation of passenger queues at stops. On the other hand, the very concept of travel strategy is changed because passengers know and trust the service time-table (this is one of the basic assumptions of schedule-based models) and can precisely select their best travel option; however, it is uncertain if they will be able to board/sit when congestion occurs.

## 2.2 Effects of countdown displays in networks with uncertainties

The effects of *way-side* (Grotenhuis *et al.*, 2007) travel information systems, such as Variable Message Signs (VMS), has been widely investigated in *traffic* networks, and the hyperpath paradigm has also been used to model drivers re/routing as consequence of real-time travel information received by means of VMS (Ukkusuri and Patil, 2007, Gao *et al.*, 2010, Gao 2012) in stochastic road networks.

Also for public transport users the support of way-side information systems, for example countdown displays, can reduce uncertainties and, thus, affect their route choice. Nevertheless, for transit networks the topic has been studied less extensively than for private traffic networks. The few existing exceptions include Hickman and Wilson (1995) and Gentile *et al.* (2005).

The authors recognize that when count-down displays are installed at transit stops the route choice behaviour described in the seminal works on hyperpaths/travel strategies ceases to be rational. Instead, it is reasonable to assume that travellers use countdown displays in order to minimise their expected total travel time to the destination and when a vehicle approaches the stop, a waiting passenger does not board it simply because it is the first attractive line arriving, but instead

1 compares its expected travel time to the destination upon boarding with the expected total travel  
2 times of later arrivals.

3 The authors only consider uncongested scenarios and acknowledge the fact that the travel time  
4 savings produced by countdown displays do not seem to be remarkable (Gentile *et al.*, 2005). On  
5 the other hand, as it will be clarified in the following sections, it is plausible to assume that in case  
6 of severe overcrowding, the provision of information may change the behaviour of public transport  
7 users and, thus, help in relieving congestion phenomena.

8  
9  
10 Consequently, in this paper the combined effect of queues and real-time travel information is  
11 investigated and a model is proposed, which may be exploited to assess if count down displays can  
12 help in relieving congestion.  
13  
14

### 15 **3 METHODOLOGY**

#### 16 **3.1 Problem definition**

17  
18  
19  
20  
21  
22 The provision of real-time information through countdown displays brings about some important  
23 demand-side effects in transit networks that are affected by recurrent congestion, as discussed  
24 here.

25  
26  
27 Depending on the design of the stop, two important sub-cases of FIFO queues may appear: either  
28 the stop is designed to have physically separate queues for each line; or passengers arriving at the  
29 stop join a single, mixed queue regardless of their attractive line set.

30  
31  
32 The first instance is very common in coach terminals. In this case, should congestion occur and no  
33 real-time information be available, passengers cannot behave strategically because they must join  
34 one specific queue as soon as they reach the stop. It may then be difficult to change queue in order  
35 to take advantage of events occurring while they are waiting (e.g. if another line arrives first).  
36 Consequently, the stop has to be modelled as a *group of separate stops*, each of which is served by  
37 one line only. However, if countdown displays are available and passengers have sufficient  
38 experience to predict how many vehicles will pass before being able to board each line, travel  
39 behaviour in the case of separate queues can also be modelled as strategic. Indeed, the information  
40 ‘anticipates’ the event of a vehicle arrival to the moment when the user reaches the stop; hence, the  
41 optimal travel strategy comes true in the moment when the traveller actually chooses which line to  
42 board, taking into account the length of the different queues. In other words, if information is  
43 provided, this case can be treated as if there were a single ‘mixed’ queue.  
44  
45  
46

47  
48  
49 The second type of stop layout (single, ‘mixed’ FIFO queue) is more common in urban public  
50 transport networks. If congestion occurs, users arriving at the stop join the queue and board the  
51 first line of their attractive set that becomes available. However, if no real-time information is  
52 provided and regular services are available, it is possible that passengers would change their  
53 attractive set while they wait, as described by Billi *et al.* (2004) and Noekel and Wekeck (2007).  
54  
55  
56 On the other hand, if information is provided, an attractive-set structuring can be modelled more  
57  
58  
59  
60

easily also in the presence of regular services because it can be assumed that passengers know the line they will board as soon as they reach the stop.

Consequently, in such a setting, the route choice can always be modelled by extending the results of Hickman and Wilson (1995) and Gentile *et al.* (2005) to a dynamic scenario where congestion phenomena are considered.

### 3.2 Network formalisation and basic notation

The transit network, which comprises a set of lines  $\mathfrak{L} \subseteq \mathfrak{N}$  ( $\mathfrak{N}$  is the set of natural integers), together with the pedestrian network is represented by a directed *hypergraph* (Gallo *et al.*, 1993)  $HG = \{N, A\}$ , where  $N = \{i \mid i = 1, 2, \dots, n\}$  is the node set and  $A = \{a \mid a = 1, 2, \dots, m\}$  is the hyperarc set. The generic hyperarc  $a$  is univocally identified by its initial, or *tail*, node  $TL_a \in N$  and its final, or *head*, node(s)  $HD_a \subset N$ , that is  $a = (TL_a, HD_a)$ . The number of nodes included in the head of the hyperarc is called *cardinality* ( $|HD_a|$ ), and hyperarcs with cardinality equal to one are also called *proper arcs* (Nguyen *et al.*, 1998) or, simply, “arcs”.

The sets of nodes and arcs, as illustrated in Figure 1, are constructed as follows:

- $N^P$ : pedestrian nodes;
- $N^C$ : centroid nodes, including all passenger origins and destination ( $N^C \subseteq N^P$ );
- $N^S$ : stop nodes;
- $N^B$ : boarding nodes;
- $N^A$ : alighting nodes;

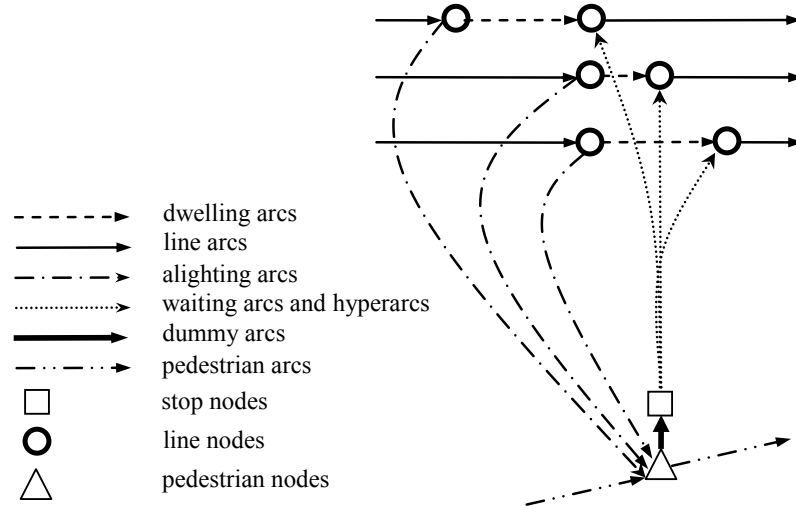

FIGURE 1: Representation of a stop in the hypergraph

- $A^P$ : pedestrian arcs, represent walking time. For each  $a \in A^P$  its tail and head belong to the pedestrian node set:  $TL_a, HD_a \in N^P, \forall a \in A^P$ ;



- 1  
2  
3  
4  
5  
6  
7  
8  
9  
10  
11  
12  
13  
14  
15  
16  
17  
18  
19  
20  
21  
22  
23  
24  
25  
26  
27  
28  
29  
30  
31  
32  
33  
34  
35  
36  
37  
38  
39  
40  
41  
42  
43
- $A^L$ : line arcs, represent in-vehicle travel time.  
 $\forall a \in A^L: TL_a \in N^B, HD_a \in N^A$ ;
- $A^D$ : dwelling arcs, representing the time a bus spends at a stop while passengers alight/board.  
 $\forall a \in A^D: TL_a \in N^A, HD_a \in A^B$ ;
- $A^Z$ : dummy arcs, are introduced for algorithmic purposes. They do not have a physical meaning, but represent a graphic connection between the transit network and the pedestrian network.  
 $\forall a \in A^Z: TL_a \in N^P, HD_a \in N^S$ ;
- $A^A$ : alighting arcs, represent the time that passengers need to disembark.  
 $\forall a \in A^A: TL_a \in N^A, HD_a \in N^P$ ;
- $A^H$ : waiting hyperarcs (Billi *et al.*, 2004), These represent the total expected waiting time for a specific set of *attractive lines* serving a stop:  $A^H \subseteq \{(i, j): i \in N^S, J \subseteq N^B, j \in J\}$ . Each waiting hyperarc  $h \in A^H$  is univocally identified by a singleton *tail* ( $TL_h$ ), which is a stop node, and by a set *head* ( $HD_h$ ) of boarding nodes. Therefore, the waiting hyperarc can be indicated as  $h = \{(TL_h, j): j \in HD_h\}$  and it can also be regarded as a set of ‘branches’, or simple *waiting arcs*  $a$ , each of which has the same tail node of  $h$  ( $TL_a = TL_h$ ) and a head node belonging to the head set of  $h$  ( $HD_a \in HD_h$ ). Moreover, the head node of a branch of a hyperarc  $h$  ( $a \in h$ ) is associated with one particular line ( $L_{HD_a}$ ) among those who share the stop represented by  $TL_a = TL_h$ .
- $FS_i$ : forward star of node  $i$ , i.e. the set of arcs sharing the same head node  $i$ .  
 $FS_i = \{a \in A \mid HD_a = i\}$ ;
- $BS_i$ : backward star of node  $i$ , i.e. the set of arcs sharing the same tail node  $i$ .  
 $BS_i = \{a \in A \mid TL_a = i\}$
- $HFS_i$ : *hyper-forward star* of node  $i \in N^S$ , i.e. the set of hyperarcs sharing the same stop tail  $i$ :  $HFS_i = \{h \in A^H: TL_h = i\}$

44 In order to represent time-dependent travel times, waiting times, etc., the following dynamic  
45 variables are also introduced with reference to the generic  $a \in h$  and  $h \in A^H$ :

- 46  
47  $\varphi_a(\tau)$ : *instantaneous frequency* (instantaneous flow of carriers) of the line  $L_{HD_a}$  evaluated  
48 at the stop node corresponding to  $TL_a$  at time  $\tau$ ,  
49  
50  $\kappa_a(\tau)$ : *congestion parameter*, expressed as the total number of vehicle arrivals that  
51 passengers are unable to board at time  $\tau$  (because of capacity constraints) before  
52 they board the line  $L_{HD_a}$ ;  
53  
54  $w_{h,d}(\tau)$ : *expected waiting time* for passengers directed towards destination  $d$ , who reach the  
55 stop  $TL_h$  at time  $\tau$  and considering the set of attractive lines represented by  $h \in A^H$ ;  
56  
57  
58  
59  
60  
61  
62  
63  
64  
65

1  $w_{a|h,d}(\tau)$ : *conditional expected waiting time*. This is the expected time before boarding the  
 2 line  $L_{HDa}$  associated with  $a \in h$  for passengers, directed towards destination  $d$ , who  
 3 reach the stop  $TL_a$  at time  $\tau$ ; its value depends on the set of attractive lines  
 4 considered, which is represented by  $h \in A^H$ ;

5  
 6  $t_{a|h,d}(\tau)$ : *conditional boarding time* on the line  $L_{HDa}$  for passengers, directed towards  
 7 destination  $d$ , who reach the stop  $TL_a$  at time  $\tau$  – namely  $t_{a|h}(\tau) = \tau + w_{a|h}(\tau)$ , and  
 8 its value depends on the set of attractive lines considered, which is represented by  
 9  $h \in A^H$ ;

10  
 11  
 12  $p_{a|h,d}(\tau)$ : *diversion probability* (Cantarella, 1997) at time  $\tau$  for passengers directed towards  
 13 destination  $d$ : ratio of passengers that board line  $L_{HDa}$  to those whose set of  
 14 attractive lines is represented by  $h \in A^H$ ;

15  
 16  
 17 PDF $_a(w_a, \tau)$ : probability distribution function (PDF) of the waiting time before boarding line  
 18  $L_{HDa}$  at time  $\tau$ ,

19  
 20  
 21  $\overline{\text{CDF}}_a(w_a, \tau)$ : survival function of the waiting time before boarding line  $L_{HDa}$  at time  $\tau$ . The  
 22 survival function indicates the probability that the variable is greater than a certain  
 23 value and it can be regarded as the opposite of the cumulative distribution function  
 24 (CDF) for the same stochastic variable, namely  $\overline{\text{CDF}}_a(w_a, \tau) = 1 - \text{CDF}_a(w_a, \tau)$ .

25  
 26  
 27  
 28 It should be noticed here that, although diversion probabilities, conditional waiting and conditional  
 29 boarding time depend on the specific destination considered, the subscript  $d$  is neglected in the  
 30 following in order to improve readability.

31  
 32 Moreover, with reference to the generic proper arc  $a \in HG \setminus \{A^H\}$  and  $i \in N$ , the following variables  
 33 are also defined:

34  
 35  $c_a(\tau)$ : *travel time* of arc  $a$  for users entering it at time  $\tau$ ;

36  
 37  $t_a(\tau)$ : *exit time* from arc  $a$  for users entering it at time  $\tau$  – namely,  $t_a(\tau) = \tau + c_a(\tau)$ ;

38  
 39  $t_a^{-1}(\tau)$ : *entry time* to the arc  $a$  for users exiting it at time  $\tau$ ;

40  
 41  $g_{i,d}(\tau)$ : *total travel time* from node  $i$  to destination  $d \in N^C$  at time  $\tau$ ;

42  
 43  $g_{i,d}^*(\tau)$ : *minimum total travel time* from node  $i$  to destination  $d \in N^C$  at time  $\tau$ .

### 44 45 **3.3 Formulation**

46  
 47  
 48 In a dynamic setting, the results of Hickman and Wilson (1995) and Gentile *et al.* (2005) are  
 49 extended to obtain a time-dependent expression for the travel cost of the minimal hyperpath from  
 50 every node to the destination:  
 51  
 52  
 53  
 54  
 55  
 56  
 57  
 58  
 59  
 60  
 61  
 62  
 63  
 64  
 65

$$g_{i,d}(\tau) = \begin{cases} 0, & \text{if } i = d \\ \min_{a \in F_{Si}} \left( c_a(\tau) + g_{HDa,d}(t_a(\tau)) \right), & \text{if } i \notin N^S \\ \min_{h \in HFS_i} \left( w_h(\tau) + \sum_{a \in h} p_{a|h}(\tau) \cdot g_{HDa,d}(t_{a|h}(\tau)) \right), & \text{if } i \in N^S \end{cases} \quad (1)$$

where:

$$p_{a|h}(\tau) = \int_0^{+\infty} \text{PDF}_a(w, \tau) \prod_{\substack{a' \in h, \\ a' \neq a}} \overline{\text{CDF}}_{a'}(w, \tau) dw \quad (2)$$

$$w_{a|h}(\tau) = \frac{1}{p_{a|h}(\tau)} \int_0^{+\infty} w \cdot \text{PDF}_a(w, \tau) \prod_{\substack{a' \in h, \\ a' \neq a}} \overline{\text{CDF}}_{a'}(w, \tau) dw \quad (3)$$

$$w_h(\tau) = \sum_{a \in h} p_{a|h}(\tau) \cdot w_{a|h}(\tau) \quad (4)$$

For each possible intermediate stop node  $i$ ,  $g_{i,d}(\tau)$  is fully defined when  $\text{PDF}_a$  and  $\overline{\text{CDF}}_{a'}$  are known; on the other hand the optimality of a travel strategy depends on the correct selection of the attractive set. Thus, the definition  $\text{PDF}_a$  and  $\overline{\text{CDF}}_{a'}$ , and the method of selection of the attractive set are core problems in the development of the new route choice model, and will be considered in detail next.

### PDFs and CDFs of the waiting times

The major assumption of the model is that in the context of commuting trips, if congestion leads to the formation of FIFO queues, passengers have a good estimate of the average number of vehicles of the same line that they must let go before being able to board (Trozzi *et al.*, 2013).

In this setting, the waiting time before boarding is a stochastic variable, whose value depends on the assumption made about service regularity. For example, if the basic hypotheses about carrier and passenger arrivals (Nguyen and Pallottino, 1988, Spiess and Florian, 1989) are not changed, the total waiting time before boarding may be modelled as an Erlang-distributed stochastic variable with parameters  $\kappa_a(\tau)$  and  $\varphi_a(\tau)$ , such that:

$$\text{PDF}_a(w, \tau) = \begin{cases} \frac{\varphi_a(\tau)^{\kappa_a(\tau)} \cdot \exp(-\varphi_a(\tau) \cdot w) \cdot w^{[\kappa_a(\tau)-1]}}{[\kappa_a(\tau)-1]!}, & \text{if } w \geq 0 \\ 0, & \text{otherwise} \end{cases} \quad (5)$$

Alternatively, when regular services with constant headways are considered, the waiting time before the first arrival is uniformly distributed and, therefore, the PDF of the total waiting time can be expressed as in equation (6).

$$PDF_a(w, \tau) = \begin{cases} \varphi_a(\tau), & \text{if } \frac{[\kappa_a(\tau)-1]}{\varphi_a(\tau)} \leq w < \frac{\kappa_a(\tau)}{\varphi_a(\tau)} \\ 0, & \text{otherwise} \end{cases} \quad (6)$$

The definition of survival functions is not as straightforward as the definition of PDF<sub>a</sub>. This is because some stops can be shared by regular and irregular services. For example, this can be the case for large bus terminals, where there are some lines whose routes run in segregated lanes (where the absence of interaction with private car traffic and/or road works enhances the service regularity) and there are also some other lines that are subject to service irregularity because their routes do not run in segregated lanes.

For this reason, the definition of equations (2) and (3) is articulated into two different subcases, depending on whether the line considered for the evaluation of its diversion probability and conditional expected waiting time has constant or exponentially distributed headways.

For example, if  $L_{HDa}$  is a service with constant headways, PDF<sub>a</sub>( $w, \tau$ ) is expressed by means of equation (5). Moreover, if:

$$\beta_{a'} = w + \frac{\kappa_a(\tau) - 1}{\varphi_a(\tau)} + g_{HDa,d} - g_{HDa',d} \quad (7)$$

then  $\overline{CDF}_a'(w + g_{HDa,d} - g_{HDa',d}, \tau)$  is expressed as in equation (8) if  $L_{HDa'}$  is a service with exponentially distributed headways; while if  $L_{HDa'}$  is a service with constant headways,  $\overline{CDF}_a'(w + g_{HDa,d} - g_{HDa',d}, \tau)$  is expressed as in equation (9).

$$\overline{CDF}_a'(w + g_{HDa,d} - g_{HDa',d}, \tau) = \sum_{j=0}^{\kappa_a(\tau)} \frac{\varphi_a(\tau)^{\kappa_a(\tau)-j} \cdot e^{-\varphi_a \cdot \beta_{a'}} \cdot \beta_{a'}^{[\kappa_a(\tau)-j]}}{(\kappa_a(\tau) - j)!} \quad (8)$$

$$\overline{CDF}_a'(w + g_{HDa,d} - g_{HDa',d}, \tau) = \begin{cases} 1, & \beta_{a'} < \frac{\kappa_a(\tau) - 1}{\varphi_a(\tau)} \\ \int_{\beta_{a'}}^{\frac{\kappa_a(\tau)}{\varphi_a(\tau)}} \varphi_a(\tau), & \frac{\kappa_a(\tau) - 1}{\varphi_a(\tau)} < \beta_{a'} < \frac{\kappa_a(\tau)}{\varphi_a(\tau)} \\ 0, & \beta_{a'} < \frac{\kappa_a(\tau)}{\varphi_a(\tau)} \end{cases} \quad (9)$$

On the other hand, in the case where  $L_{HDa}$  is a service with exponentially distributed headways, then PDF<sub>a</sub>( $w, \tau$ ) is expressed by means of equation (6), while  $\overline{CDF}_a'(w + g_{HDa,d} - g_{HDa',d}, \tau)$  is expressed by equations (8) and (9) for irregular and regular services respectively, where  $\beta_{a'}$  is defined as:

$$\beta_{a'} = w + g_{HDa,d} - g_{HDa',d} \quad (10)$$

## Attractive set

In general, the above expressions of the diversion probabilities and expected waiting times can be applied to any hyperarc  $h \in HFS_i$ . However, only a specific *waiting hyperarc* is associated with the set of lines that are mostly convenient to board, at time  $\tau$ , in order to reach the destination in the minimum time.

The lines to be included in the waiting hyperarc (or, equivalently, in the attractive set) generally depend on the time  $\tau$  when the set is evaluated and can be determined by solving a combinatorial problem. At least for the static case, the problem of determining the attractive set can be simplified because it is counter-intuitive to exclude a line from the choice set if it has a shorter remaining travel time than any other line already included in the set. Therefore, a greedy approach may be applied (Spiess and Florian, 1989, Nguyen and Pallottino, 1988, Chriqui and Robillard, 1975) by processing the lines in ascending order of their travel time upon boarding and the progressive calculation of the values of  $p_{a|h}$ ,  $w_h$ , and  $g_{i,d}$  is stopped as soon as the addition of the next line increases the value of  $g_{i,d}$ . At this point, the cost is minimal and the set of lines corresponds to the *attractive set*.

The correctness of the greedy method, in the static case, depends on the shape of the waiting time PDF (exponential). While this does not hold in the dynamic scenario, a greedy procedure is suggested anyhow for the application of the proposed model to real-scale networks, where the solution of the full combinatorial problem may become computationally intractable.

## 4 THE ALGORITHM

As mentioned in the introduction, the proposed route choice model should be embedded in a full dynamic transit assignment procedure. Consequently, a solution algorithm is needed to perform the shortest time-dependent many-to-one (hyper)path search for *every* possible arrival/departure time.

To this end, the Decreasing Order of Time (DOT) method, presented by Chabini (1998) and having been analytically proven to be the most efficient solution method for the all-to-one search for every possible arrival time, is extended to the time-dependent shortest hyperpath problem. It should be noted here that although the proposed model has a continuous time representation, a discrete-time representation is adopted for its numerical solution.

The main idea is to divide the analysis period  $P = [0, T]$  into  $\Theta$  time intervals, such that  $AP = \{\tau^0, \tau^1, \dots, \tau^\theta, \dots, \tau^{\Theta-1}\}$ , with  $\tau^0 = 0$  and  $\tau^{\Theta-1} = T$ , and to replicate the network along the time dimension, forming a time-expanded hypergraph  $HG_T$ , where nodes and (hyper)arcs have an explicit time dimension and are, respectively, called *vertices* and (hyper)*edges*. If time intervals are short enough to ensure that the exit time of a generic edge  $t_d(\tau^\theta)$  is not earlier than the next interval  $\tau^{\theta+1}$ , for  $\tau \leq \Theta-2$ , it is ensured that the network is cycle-free and the *vertex* chronological ordering is equivalent to the topological one. Thus,  $HG_T$  is scanned starting from the last temporal layer to the value assumed for  $\tau = \tau^0$  and, within the generic layer, no topological order is

1  
2  
3  
4  
5  
6  
7  
8  
9  
10  
11  
12  
13  
14  
15  
16  
17  
18  
19  
20  
21  
22  
23  
24  
25  
26  
27  
28  
29  
30  
31  
32  
33  
34  
35  
36  
37  
38  
39  
40  
41  
42  
43  
44  
45  
46  
47  
48  
49  
50  
51  
52  
53  
54  
55  
56  
57  
58  
59  
60  
61  
62  
63  
64  
65

respected. When a generic vertex  $(i, \tau^\theta)$  is visited, its forward star is scanned in order to set the minimal travel cost to destination and the successive edge by means of equation (1). In fact, at this point of the algorithm, not only the costs of the edges  $a = \left( (TL_a, \tau^\theta), (HD_a, t_a(\tau^\theta)) \right)$  of the forward star, but also the minimal costs from every vertex  $(HD_a, t_a(\tau^\theta))$  to destination are known. If the examined vertex represents a stop node in the time-expanded hypergraph, then the successive edge corresponds to a hyperarc of the hypergraph  $HG$  and it is determined by means of the greedy procedure detailed in Section 4.1.

By assumption the network behaves as static outside the analysis period, therefore for departure time intervals greater than or equal to  $\Theta-1$  the computation of the shortest hyperpath is equivalent to a static procedure and is calculated according the algorithm by Spiess and Florian (1989).

#### 4.1 Time-dependent shortest hypertree algorithm for every possible arrival time

Beyond variables already specified, the algorithm also includes:

- $\theta$  time interval index;
- $\theta \text{Int}$ : time interval length;
- $d$ : destination node;
- $i$ : generic node;
- $FS_i$ : set of arcs belonging to the forward star of node  $i$ ;
- $HFS_i$ : set of hyperarcs belonging to the hyper-forward star of node  $i$ ;
- $a = (i, j)$ : generic arc and/or branch of hyperarc  $a \in h$ ;
- $h$ : generic hyperarc;
- $suc(i, \tau^\theta)$ : successor arc and/or hyperparc of the generic node  $i$  at time interval  $\tau^\theta$ ;
- $c_a(\tau^\theta)$ : generalised travel time on arc  $a$  at time interval  $\tau^\theta$ ,  $a \in A \setminus \{A^H\}$ ;
- $\varphi_a(\tau^\theta)$ : instantaneous frequency corresponding to the line associated with arc  $a$  at time interval  $\tau$ ,  $a \in FS_i$ ,  $i \in N^S$ ;
- $t_a(\tau^\theta)$ : exit time from arc  $a$  for users entering it at time interval  $\tau^\theta$ ;
- $t_a^{-1}(\tau^\theta)$ : entry time to the arc  $a$  for users exiting it at time  $\tau^\theta$ ;
- $\kappa_a(\tau^\theta)$ : congestion parameter at time interval  $\tau^\theta$  for the line  $L_{HDa}$  associated with the arc  $a \in FS_i$ ,  $i \in N^S$ ;
- $p_{a|h}(\tau^\theta)$ : diversion probability at time interval  $\tau^\theta$
- $w_{a|h}(\tau^\theta)$ : conditional expected waiting time at time interval  $\tau^\theta$ ;
- $w_h(\tau^\theta)$ : waiting time at node  $i = TL_h$  at time interval  $\tau^\theta$ ;
- $g_{i,d}(\tau^\theta)$ : current travel cost from generic node  $i$  to destination  $d$  at time interval  $\tau^\theta$ ;
- $g_{i,d,h}(\tau^\theta)$ : current travel cost from stop node  $i$  to destination  $d$  at time interval  $\tau^\theta$  if considering the attractive line represented by hyperarc  $h$ ;

- $g^*_{i,d}(\tau^\theta)$ : minimum travel cost from generic node  $i$  to destination  $d$  at time interval  $\tau^\theta$ ;
- $g^*_{i,d}{}^{\text{stat}}$ : minimum travel cost from generic node  $i$  to destination  $d$  at time interval  $\tau^\theta \geq \tau^{\theta-1}$ ;

The pseudo-code of the solution algorithm for the time-dependent all-to-one shortest hyperpath problem for every possible arrival time is, hence, detailed:

Step 0 (SSHP – Initialisation):  $\forall i \in N \setminus \{d\}$

Calculate  $g^*_{is}(\tau^{\theta-1}) = g^*_{is}{}^{\text{stat}}$

$\theta \in [0, \Theta-2]$

Set  $g^*_{d,d}(\tau^\theta) = 0, \text{suc}(d, \tau^\theta) = \emptyset$

$i \in N \setminus \{d\}$

Set  $g^*_{i,d}(\tau^\theta) = \infty$

Step 1 (Calculate hyperpath travel time):  $\theta \in [0, \Theta-2]$

$i \in N \setminus \{d\}$

If  $i \in N^S$ ,

Apply the greedy procedure to define the set of attractive lines and calculate the travel cost

$g^*_{i,d}(\tau^\theta) = g_{i,d,h}(\tau^\theta)$  and  $\text{suc}(i, \tau^\theta) = h$

Else if  $i \notin N^S, a \in FS_i$

If  $\lfloor c_a(\tau^\theta) / \Theta \text{nt} \rfloor \geq 1$

$t_a(\tau^\theta) = \lfloor c_a(\tau^\theta) / \Theta \text{nt} \rfloor + \tau^\theta$

Else

$t_a(\tau^\theta) = \tau^\theta + 1$

$g_{i,d}(\tau^\theta) = c_a(\tau^\theta) + g_{HD_a,d}(t_a(\tau^\theta))$

If  $g^*_{i,d}(\tau^\theta) > g_{i,d}(\tau^\theta)$

$g^*_{i,d}(\tau^\theta) = g_{i,d}(\tau^\theta)$  and  $\text{suc}(i, \tau^\theta) = a$

The greedy-like procedure invoked in Step 1 of the solution algorithm requires that once a stop node  $i$  is reached, all lines  $L_{HD_a}, a \in FS_i$ , are sorted in increasing order of travel time upon boarding ( $g_{HD_a,d}$ ). In general,  $g_{HD_a,d}$  should be evaluated for each line  $L_{HD_a}$ , at the conditional boarding time  $t_{a|h}(\tau^\theta)$  and this value, in turns, does not only depend on the particular line  $L_{HD_a}$  considered, but also on what other lines are included in the choice set (hyperarc  $h$ ).

Because at this stage the attractive hyperarc has not been determined yet, the following hyperarcs are defined:

$$h_l = a_l, \quad l = \{1, 2, \dots, n\} \quad (11)$$

and lines are sorted according to the following criterion:

$$g_{HDa_1,d}(t_{a_1|h_1}(\tau)) \leq g_{HDa_2,d}(t_{a_2|h_2}(\tau)) \leq \dots \leq g_{HDa_n,d}(t_{a_n|h_n}(\tau)), \quad n = |FS_i| \quad (12)$$

The rest of the greedy-type procedure adopted follows as normal: one line at a time is added to the attractive set and the calculation is stopped as soon as the addition of the next line increases the value of  $g_{i,d,h}$ .

Step 1.0 (Initialisation):  $\forall a \in FS_i, a \in A^W$

Set  $h_l = a_l$ , according to equation (11)

Sort  $a_l \in FS_i$ , according to equation (12)

Set  $h := a_l$

Calculate  $w_{a_l|h}(\tau^\theta)$  with equation (3)

If  $\llbracket w_{a_l|h}(\tau^\theta) / \theta \text{Int} \rrbracket \geq 1$

$$t_{a_l|h}(\tau^\theta) = \llbracket w_{a_l|h}(\tau^\theta) / \theta \text{Int} \rrbracket + \tau^\theta$$

Else

$$t_{a_l|h}(\tau^\theta) = \tau^\theta + 1$$

Calculate  $w_h(\tau^\theta)$  with equation (4)

$$g_{i,d,h}(\tau^\theta) := w_h(\tau^\theta) + g_{HDa_l,d}(t_{a_l|h_l}(\tau^\theta))$$

$l := 2$

Step 1.1 (Updating  $h$ ): While  $(l \leq n)$  and  $g_{HDa_l,d}(t_{a_l|h_l}(\tau^\theta)) < g_{i,d,h}(\tau^\theta)$  do:

$h := h \cup \{a_l\}$

$\forall a \in h$

Calculate  $p_{a|h}(\tau^\theta)$  with equation (2)

Calculate  $w_{a|h}(\tau^\theta)$  with equation (3)

Calculate  $w_h(\tau^\theta)$  with equation (4)

If  $\llbracket w_{a|h}(\tau^\theta) / \theta \text{Int} \rrbracket \geq 1$

$$t_{a|h}(\tau^\theta) = \llbracket w_{a|h}(\tau^\theta) / \theta \text{Int} \rrbracket + \tau^\theta$$

Else

$$t_{a|h}(\tau^\theta) = \tau^\theta + 1$$

$$g_{i,d,h}(\tau^\theta) = w_h(\tau^\theta) + \sum_{a \subseteq h} p_{a|h}(\tau^\theta) \cdot g_{HD_a|h}(\tau^\theta)$$

$l := l + 1$



## 5 NUMERICAL EXAMPLE

A numerical example is presented in order to show the effects of queues on passenger route choice, when information about actual waiting times is provided at transit stops. The example network is the same used by Spiess and Florian (1989) in their seminal work on optimal travel strategies in static networks, and is depicted in Figure 2a.

For the scope of this example, the analysis morning peak period [07:30–09:30] is divided in one-minute intervals. In order to fully consider the effect of queues and information, frequencies and in-vehicle travel times are assumed to stay equal to the values depicted in Figure 2a, and all lines are irregular, with exponentially distributed headways.

By contrast, it is assumed that since 08:00 a queue arises at stop node 3, such that passengers wishing to board line arc 17 have to wait for the second arrival of the corresponding transit Line 004. Also, from 08:30 onwards, a queue arises at stop node 1 and passengers wanting to board Line 001 or Line 002 have to wait for the second carrier. Before 08:00 and from 09:30 onwards there is no passenger congestion, so the problem can be considered static and the optimal travel strategy from each node to destination (node 16) is depicted in Figure 2b, where in bold are represented values calculated without considering the effect of countdown displays.

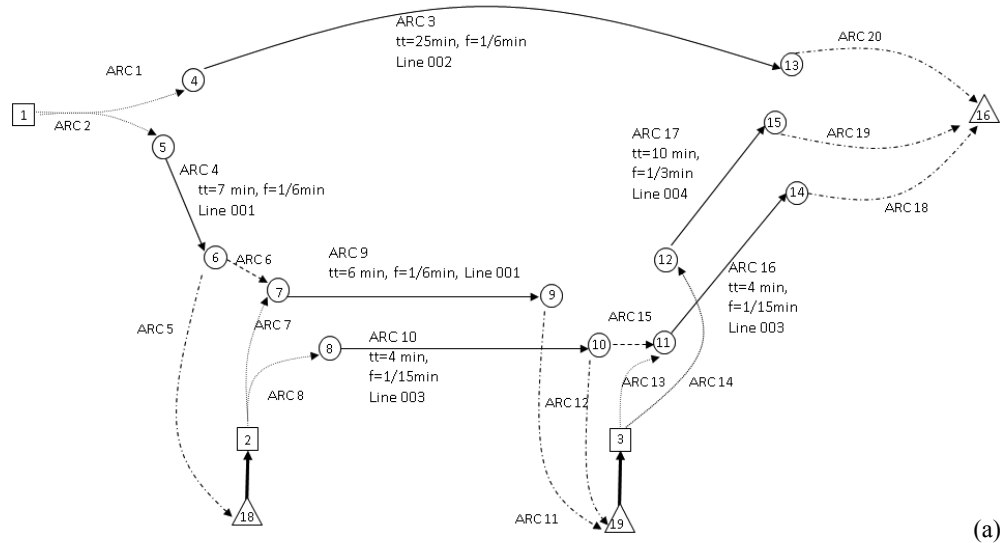

1  
2  
3  
4  
5  
6  
7  
8  
9  
10  
11  
12  
13  
14  
15  
16  
17  
18  
19  
20  
21  
22  
23  
24  
25  
26  
27  
28  
29  
30  
31  
32  
33  
34  
35  
36  
37  
38  
39  
40  
41  
42  
43  
44  
45  
46  
47  
48  
49  
50  
51  
52  
53  
54  
55  
56  
57  
58  
59  
60  
61  
62  
63  
64  
65

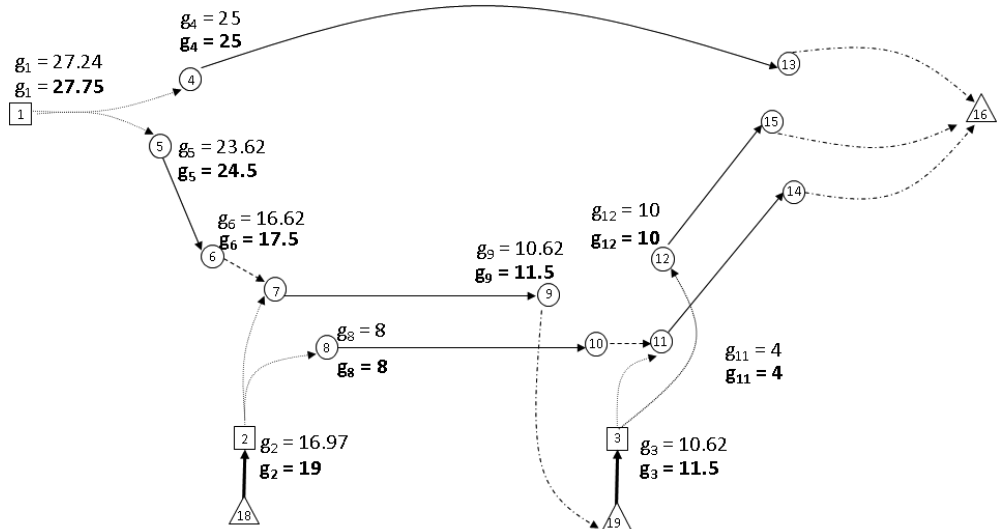

FIGURE 2  
 (a): hypergraph representation of the example network with in-vehicle travel times (tt) and average frequencies (f) of each line  
 (b): travel times to destination (node 16) outside the analysis period, expressed in minutes. In bold are the values calculated without considering the effect of countdown displays

The effects of congestion at a stop with a *mixed* FIFO queue are shown in Figure 3 for the case where information is provided (a) and not provided (b). If information is provided and a *mixed* queue arises at stop 3, passengers that have boarded Line 001 at stop 1 prefer to alight at stop 2 rather than staying on board. The behaviour is perfectly rational because, should they stay on board (i.e. the dwelling arc 6 of Figure 2a is included in the optimal strategy), they would necessarily alight at stop 3 and experience, there, the queuing delay due to oversaturation. Interestingly, if no real-time bus departure information is provided the optimal travel strategy is to stay on-board, as depicted in Figure 3b. Therefore it could be inferred that when information mitigates the uncertainty, due to service irregularity, the expectation of congestion, further down along the trip, seems to influence local choices more than the waiting time at the current location. On the other hand, in case of full uncertainty (irregular services and no additional information) the decision tends to be more myopic and to consider mainly the local delay.

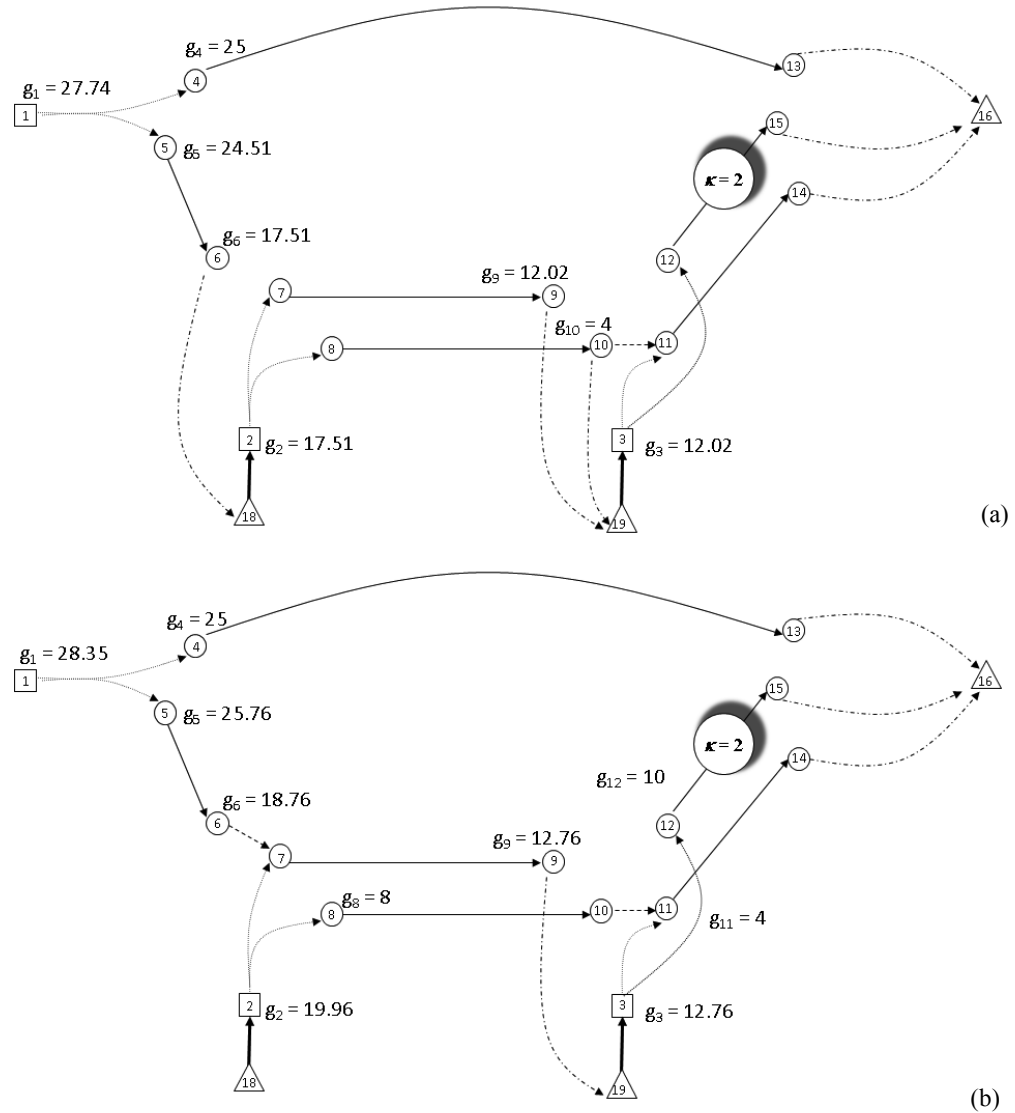

FIGURE 3

(a): travel times in minutes from each node to destination (node 16) when countdown displays are available at each stop and passenger queues are 'mixed'

(b): travel times in minutes from each node to destination (node 16) when countdown displays are not available at each stop and passenger queues are 'mixed'

The effects of congestion at a stop with a *separate* FIFO queues (e.g. bus terminals), are shown in Figure 4, where it is assumed that stop 1 has such a layout. If *no* countdown displays are available and congestion occurs, as soon as passengers arrive at the stop, they have to join either the queue for boarding Line 001 or the queue for boarding Line 002. Consequently, they cannot take advantage of events taking place while they are waiting at the stop and no travel strategy is possible. In this scenario, a rational passenger will compare the total travel time of boarding Line 001 (12' expected waiting time + 25' travel time upon boarding = 37'), the total travel time of

boarding Line 002 (12' expected waiting time + 24.5' travel time upon boarding = 36.5') and will choose the second option, as in Figure 4a.

By contrast, if information is provided at stop 1, the route choice can be *strategic* also in case of passenger congestion, as explained in Section 2, and will result in the hypertree depicted in Figure 4b. Because in this case the provision of real-time information allows for a travel strategy, the decrease in total travel time is quite substantial and, with reference to the *o-d* pair 1-16, it accounts for 11.35% of the total travel time, while in the first instance (no congestion) the reduction is only of 0.5 minutes (1.8%), and in the second instance (08:30-09:00) it is only of 0.51 minutes (1.9%).

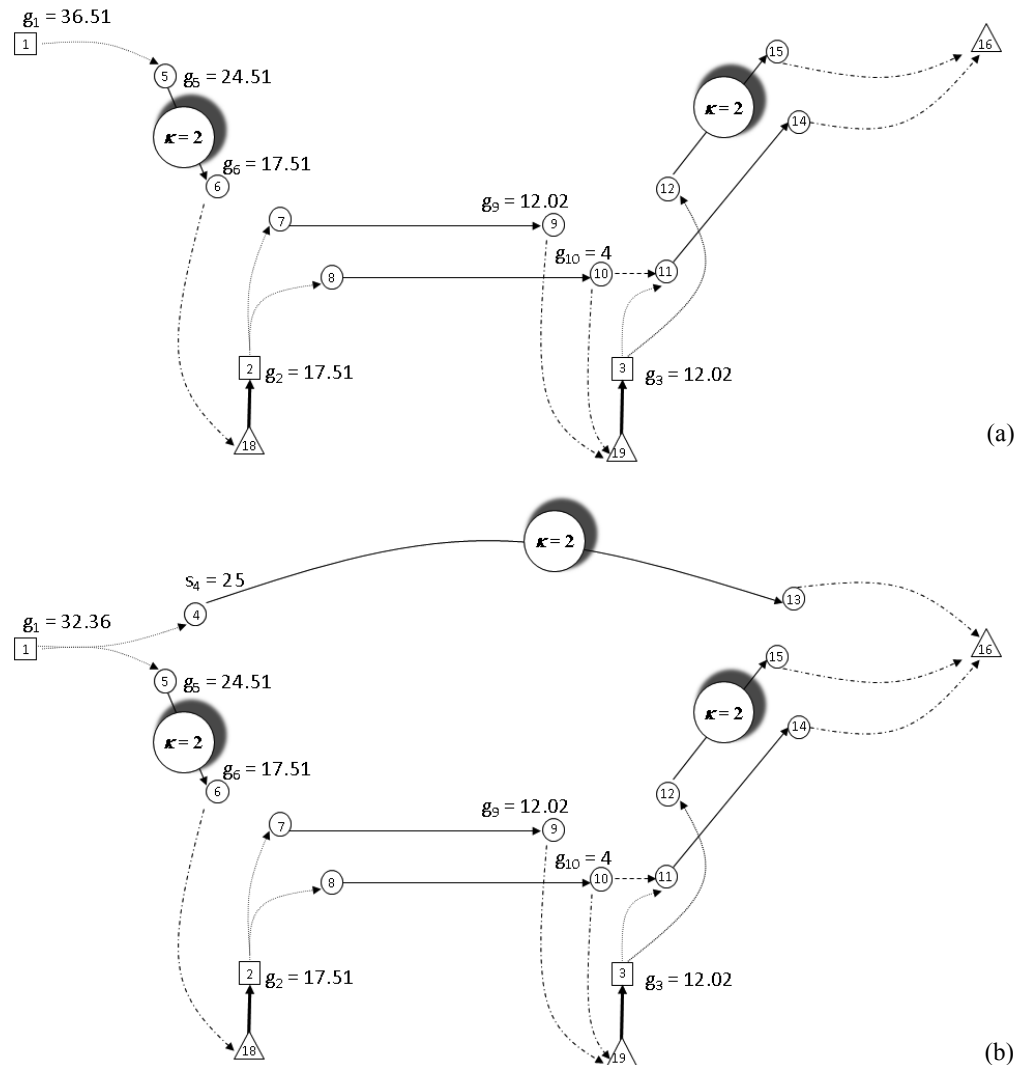

FIGURE 4

(a): travel times in minutes from each node to destination (node 16) when countdown displays are not available at each stop. The passenger queues at stop 1 are *separate* and ‘*mixed*’ at stop 3

(b): travel times in minutes from each node to destination (node 16) when countdown displays are available at each stop. The passenger queues at stop 1 are *separate* and ‘*mixed*’ at stop 3 and passenger queues are ‘*mixed*’.

## 6 CONCLUSIONS

In this paper a time-dependent route choice model and algorithm have been presented to assess the effects of cont down displays under sever overcrowding.

Assuming that congestion can be represented by a First-In-First-Out (FIFO) queue of passengers at transit stops, it has been shown that the route choice model independently developed by Hickman and Wilson (1995) Gentile *et al.* (2005) can also be applied to time-dependent, congested scenarios, provided that the selection method for the attractive set and the waiting times' probability distribution function (PDF) and survival function ( $\overline{\text{CDF}}$ ) are changed in accordance with the new hypotheses. The presence of real-time information at stops ensures that the model can describe route choice both in case of *separate* or *'mixed'* queues. Moreover, the different adaptive behaviours considered by Billi *et al.* (2004) and Noekel and Weckeck (2007) in case of regular services can be disregarded.

The proposed model cannot devise an exact solution for services with an intermediate degree of regularity because in this case it is usually assumed that the PDF of the waiting time before the first carrier arrives follows an Erlang distribution, which cannot be convoluted. On the other hand, the model represents a step forward with respect of those usually applied for representing route choice in congested scenarios because it can handle easily both the case of perfectly irregular services (i.e. lines with exponentially distributed headways, this is the case usually considered in models with capacity constraints) and perfectly regular services (i.e. lines with constant headways), for which an exact solution is devised.

Finally, it should be highlighted here that the application envisaged for the proposed route choice model is dynamic transit assignment and not passenger routing. This is for two main reasons. First, the congestion parameter  $\kappa_a(\tau)$  can only be evaluated by means of a queuing model embedded in a full assignment procedure, for example like the one presented in (Trozzi *et al.*, 2013).

Second, notwithstanding the inherent uncertainty and stochasticity on the supply-side, the proposed deterministic model only considers *average* values of the waiting and in-vehicle travel time, independently from their actual realization on a particular day. In dynamic routing applications, this would lead to a distortion in the computation of travel times, as the following examples clarify. Consider a stop  $i$ , a set of attractive lines represented by hyperarc  $h$  and the attractive line  $L_{HDa}$  ( $a \subseteq h$ ): on a specific day the actual realization of the waiting time before boarding  $L_{HDa}$  may be different than the conditional expected value  $w_{ah}(\tau)$  and thus those who have reached stop  $i$  at time  $\tau$  will be subject to a different travel time upon boarding than  $\mathcal{G}_{HD_a,h}(t_{ah}(\tau))$ . Similarly, if on a specific day the in-vehicle travel time on the first lag of the journey is different than the expected value, the passenger will experience at the transferring stop a queuing delay that is generally different than what expected.

1 While these (small) distortions would not allow an application of the proposed model for dynamic  
2 routing purposes, it can always be embedded into a dynamic deterministic transit assignment  
3 procedure where, in general, average traffic conditions and travel times are considered.

4 Hence, future work will concentrate on dynamic transit assignment applications to real-scale  
5 networks in order to fully evaluate the potential congestion relief brought about by countdown  
6 displays. Moreover, applications to medium-size networks will also be implemented to evaluate  
7 the impact of the proposed greedy heuristic for the selection of the line choice set.  
8  
9

## 10 REFERENCES

- 11  
12  
13  
14  
15 BILLI, C., GENTILE, G., NGUYEN, S., PALLOTTINO, S. & BARRETT, K.  
16 Rethinking the wait model at transit stops. Proceedings of TRISTAN V -  
17 Triennial Symposium on Transportation Analysis, 2004 2004.  
18  
19 BOUZAÏENE-AYARI, B. 1988. *Modélisation des arrêts multiples d'autobus*  
20 *pour les réseaux de transport en commun.*, École Polytechnique de  
21 Montréal.  
22  
23 BOUZAÏENE-AYARI, B., GENDREAU, M. & NGUYEN, S. 2001. Modeling  
24 Bus Stops in Transit Networks: A Survey and New Formulations.  
25 *Transportation Science*, 35, 304-321.  
26  
27 CEPEDA, M., COMINETTI, R. & FLORIAN, M. 2006. A frequency-based  
28 assignment model for congested transit networks with strict capacity  
29 constraints: characterization and computation of equilibria. *Transportation*  
30 *research Part Part B: Methodological*, 40, 437-459.  
31  
32 CHABINI, I. 1998. Discrete dynamic shortest path problems in transportation  
33 applications: complexity and algorithms with optimal running time.  
34 *Transportation Research Record: Journal of the Transportation Research*  
35 *Board*, 1645, 170-175.  
36  
37 CHRIQUI, C. & ROBILLARD, P. 1975. Common bus lines. *Transportation*  
38 *Science*, 9, 115-121.  
39  
40 COMINETTI, R. & CORREA, J. 2001. Common-Lines and Passenger  
41 Assignment in Congested Transit Networks. *Transportation Science*, 35,  
42 250 - 267.  
43  
44 DE CEA, J. & FERNANDEZ, E. 1993. Transit Assignment for Congested Public  
45 Transport Systems: An Equilibrium Model. *Transportation Science*, 27,  
46 133-147.  
47  
48 GALLO, G., LONGO, G., PALLOTTINO, S. & NGUYEN, S. 1993. Directed  
49 Hypergraphs and Applications. *Discrete Applied Mathematics*, 42, 177-  
50 201.  
51  
52 GAO, S., FREJINGER, E., BEN-AKIVA, M. 2010. Adaptive Route Choices in  
53 Risky Traffic Networks: A Prospect Theory Approach. *Transportation*  
54 *Research Part C: Emerging Technologies*, 18(5), 727-740.  
55  
56 GAO, S. 2012. Modeling Strategic Route Choice and Real-Time Information  
57 Impacts in Stochastic and Time-Dependent Networks. *Intelligent*  
58 *Transportation Systems, IEEE Transactions on*, 13(3), 1298-1311.  
59  
60 GENDREAU, M. 1984. *Étude approfondie d'un modèle d'équilibre pour*  
61 *l'affectation des passagers dans les réseaux de transport en commun.*  
62  
63  
64  
65

- 1 GENTILE, G., NGUYEN, S. & PALLOTTINO, S. 2005. Route Choice on  
2 Transit Networks with Online Information at Stops. *Transportation*  
3 *Science*, 39, 289-297
- 4 GROTENHUIS, J.-W., WIEGMANS, B., W., RIETVEL, P. 2007. The desired  
5 quality of integrated multimodal travel information in public transport:  
6 Customer needs for time and effort savings. *Transport Policy*, 14, 27-38.
- 7 HAMDOUCH, Y., HO, H. W., SUMALEE, A. & WANG, G. 2011. Schedule-  
8 based transit assignment model with vehicle capacity and seat availability.  
9 *Transportation Research Part B: Methodological*, 45, 1805-1830.
- 10 HAMDOUCH, Y. & LAWPHONGPANICH, S. 2008. Schedule-based transit  
11 assignment model with travel strategies and capacity constraints.  
12 *Transportation Research Part B: Methodological*, 42, 663-684.
- 13 HAMDOUCH, Y., MARCOTTE, P. & NGUYEN, S. 2004. A Strategic Model for  
14 Dynamic Traffic Assignment. *Networks and Spatial Economics*, 4, 291-  
15 315.
- 16 HICKMAN, M. D. & WILSON, N. H. M. 1995. Passenger travel time and path  
17 choice implications of real-time transit information. *Transportation*  
18 *Research Part C: Emerging Technologies*, 3, 211-226.
- 19 KURAUCHI, F., BELL, M. G. H. & SCHMÖCKER, J. D. 2003. Capacity  
20 Constrained Transit Assignment with Common Lines. *Journal of*  
21 *Mathematical Modelling and Algorithms*, 2, 309-327.
- 22 LEURENT, F. & BENEZECH, V. 2011. The Passenger Stock and Attractivity  
23 Threshold model for traffic assignment on a transit network with capacity  
24 constraint. *Transportation Research Board, 90th Annual Meeting*.  
25 Washington, D.C.
- 26 MILLER-HOOKS, E., D. & MAHMASSANI, H., S. 2000. Least Expected Time  
27 Paths in Stochastic, Time-Varying Transportation Networks.  
28 *Transportation Science*, 3(2), 198-215.
- 29 NGUYEN, S. & PALLOTTINO, S. 1988. Equilibrium traffic assignment for large  
30 scale transit networks. *European Journal of Operational Research*, 37,  
31 176-186.
- 32 NGUYEN, S. & PALLOTTINO, S. 1989. Hyperpaths and shortest hyperpaths.  
33 *Combinatorial Optimization*. Berlin / Heidelberg: Springer
- 34 NGUYEN, S., PALLOTTINO, S. & GENDREAU, M. 1998. Implicit  
35 enumeration of hyperpaths in a logit model for transit networks.  
36 *Transportation Science*, 32, 54.
- 37 NOEKEL, K. & WEKECK, S. Choice models in frequency-based transit  
38 assignment. European Transport Conference 2007 2007.
- 39 PRETOLANI, D. 2000. A directed hypergraph model for random time dependent  
40 shortest paths. *European Journal of Operational Research*, 123 (2), 315-  
41 324.
- 42 SCHMÖCKER, J.-D., BELL, M. G. H. & KURAUCHI, F. 2008. A quasi-  
43 dynamic capacity constrained frequency-based transit assignment model.  
44 *Transportation Research Part B: Methodological*, 42, 925-945.
- 45 SPIESS, H. 1983. On optimal route choice strategies in transit networks. In:  
46 CENTRE DE RECHERCHE SUR LES TRANSPORTS, U. D. M. (ed.).
- 47 SPIESS, H. 1984. *Contributions à la théorie et aux outils de planification des*  
48 *réseaux de transport urbain*. Ph.D. Thesis Ph.D. Thesis, Université de  
49 Montréal.

- 1  
2  
3  
4  
5  
6  
7  
8  
9  
10  
11  
12  
13  
14  
15  
16  
17  
18  
19  
20  
21  
22  
23  
24  
25  
26  
27  
28  
29  
30  
31  
32  
33  
34  
35  
36  
37  
38  
39  
40  
41  
42  
43  
44  
45  
46  
47  
48  
49  
50  
51  
52  
53  
54  
55  
56  
57  
58  
59  
60  
61  
62  
63  
64  
65
- SPIESS, H. & FLORIAN, M. 1989. Optimal strategies: A new assignment model for transit networks. *Transportation Research Part B: Methodological*, 23, 83-102.
- TEKLU, F. 2008. A Stochastic Process Approach for Frequency-based Transit Assignment with Strict Capacity Constraints. *Networks and Spatial Economics*, 8, 225-240.
- TROZZI, V., GENTILE, G., BELL, M. G. H. & KAPARIAS, I. 2013. Dynamic User Equilibrium in Public Transport Networks with Passenger Congestion and Hyperpaths. *Transportation Research Part B: Methodological*, in press doi: 10.1016/j.trb.2013.06.011.
- UKKUSURI, S.V. & PATIL, G. 2007. Exploring user behavior in online network equilibrium problems. *Transportation Research Record: Journal of the Transportation Research Board*, 2029, 31-38.
- YANG, B. & MILLER-HOOKS ,E.,D. 2004. Adaptive routing considering delays due to signal operations. *Transportation Research Part B: Methodological*, 38(5), 385–413.