



## City Research Online

### City, University of London Institutional Repository

---

**Citation:** Phillips, J. P., Langford, R. M., Chang, S. H., Maney, K., Kyriacou, P. A. & Jones, D. P. (2009). Evaluation of a Fiber-optic Esophageal Pulse Oximeter. Paper presented at the EMBC 2009. Annual International Conference of the IEEE, 3-6 Sept. 2009, Minneapolis, MN.

This is the accepted version of the paper.

This version of the publication may differ from the final published version.

---

**Permanent repository link:** <https://openaccess.city.ac.uk/id/eprint/13353/>

**Link to published version:**

**Copyright:** City Research Online aims to make research outputs of City, University of London available to a wider audience. Copyright and Moral Rights remain with the author(s) and/or copyright holders. URLs from City Research Online may be freely distributed and linked to.

**Reuse:** Copies of full items can be used for personal research or study, educational, or not-for-profit purposes without prior permission or charge. Provided that the authors, title and full bibliographic details are credited, a hyperlink and/or URL is given for the original metadata page and the content is not changed in any way.

---

City Research Online:

<http://openaccess.city.ac.uk/>

[publications@city.ac.uk](mailto:publications@city.ac.uk)

---

# Evaluation of a Fiber-optic Esophageal Pulse Oximeter

Justin P. Phillips, *Member, IEEE*, Richard M. Langford, Serene H. Chang, Kishore Maney, Panayiotis A. Kyriacou, *Senior Member, IEEE*, Deric P. Jones, *Senior Member, IEEE*.

**Abstract**—A dual-wavelength fiber-optic pulse oximetry system was developed for the purposes of estimating oxygen saturation from the esophagus. A probe containing miniature right-angled glass prisms was used to record photoplethysmographic (PPG) signals from the esophageal wall. Signals were recorded successfully in 19 of 20 patients, demonstrating that PPG signals could be reliably obtained from an internal vascularized tissue site such as the esophageal epithelium. The value of the mean oxygen saturation recorded from the esophagus was  $94.0 \pm 4.0\%$ . These results demonstrate that  $\text{SpO}_2$  may be estimated in the esophagus using a fiber-optic probe and this may be the first report of such measurements.

## I. INTRODUCTION

An optical fiber-based oximetry system was designed for estimating the oxygen saturation ( $\text{SpO}_2$ ) in internal tissue from photoplethysmographic signals obtained using red and infrared light sources. The esophagus was chosen as a suitable internal measurement site since it is easily accessible in anesthetized patients. To overcome the problems associated with the measurement of  $\text{SpO}_2$  in states of poor peripheral perfusion, Kyriacou et al. described a reflectance esophageal pulse oximetry system [1]. The esophageal probe comprised two infrared and two red LEDs arranged adjacent to a photodetector and was designed to fit into a size 20 French gauge plastic transparent disposable naso-gastric tube [2]. In a clinical trial of the system by Kyriacou et al. [3, 4], the esophageal and finger PPGs and  $\text{SpO}_2$  in 49 patients undergoing hypothermic cardi thoracic bypass surgery were compared. Photoplethysmographic signals were observed at various depths in the esophagus and esophageal  $\text{SpO}_2$  values were compared with those measured using a commercial finger pulse oximeter. Measurable PPG traces at red and infrared wavelengths were obtained in the esophagus in all 49 patients [3].

It was found that five of the 49 patients in this study had one or more periods of at least ten consecutive minutes, during which the commercial finger pulse oximeter failed to display PPG signals and  $\text{SpO}_2$  values, despite being correctly positioned on the finger.

J. P. Phillips, P.A. Kyriacou and D.P. Jones are with the School of Engineering and Mathematical Sciences, City University, London, EC1V 0HB, UK (e-mail: justin.phillips.1@city.ac.uk)

S. H. Chang, K. Maney and R. M. Langford are with the Anaesthetic Laboratory, St Bartholomew's Hospital, London, EC1A 7BE, UK (e-mail: r.m.langford@btconnect.com).

Conversely, the esophageal pulse oximeter operated successfully throughout these periods. Use of the esophageal pulse oximeter has also been successfully demonstrated in patients suffering from major burns [5]. Another study using a smaller version of the esophageal pulse oximetry probe showed that reliable signals could be obtained from neonatal and pediatric patients [6].

The motivation for an esophageal probe is to provide a means of measuring oxygen saturation relatively non-invasively in anesthetised patients in whom peripheral finger or ear probes are unsuitable, for example in patients with hypothermia, major burns or compromised peripheral perfusion due to diseases such as Raynaud's syndrome. The line of investigation outlined above was extended by using optical fibers to transmit light to and from the tissue. In the present study, a fiber-optic probe for use in the esophagus was designed and evaluated in 20 patients undergoing surgery requiring tracheal intubation and mechanical ventilation. Optical fibers are of interest since their use confers the benefit of electrical isolation of the patient from the optoelectronic components. The use of optical fibers to transmit photoplethysmographic signals from tissue has been demonstrated in other applications [7, 8]. The esophageal probe utilises a pair of prisms to change the path of the light through an angle of  $90^\circ$ , so the light is transmitted perpendicular to the axis of the transmitting fiber (unlike a bare fiber which transmits light in a cone, whose axis is aligned with the cylindrical axis of the fiber) and similarly, the probe is sensitive to light back-scattered from the esophageal wall.

## II. MATERIALS AND METHODS

### A. Fiber-optic esophageal reflectance probe

The esophageal probe was constructed from a pair of glass optical fibers with a core diameter of  $600 \mu\text{m}$  terminated at the proximal end with SMA connectors. The distal end was polished flat using Grade 5 followed by Grade 3 sandpaper. A right-angled glass prism (Edmund Optics, York, UK) of dimensions  $2 \text{ mm} \times 2 \text{ mm} \times 2 \text{ mm}$  was affixed to the ends of each optical fiber using 144-M glass adhesive (Dymax Inc., Torrington, CT, USA). The fiber ends and prisms were then encased in a cylindrical epoxy resin (ER1100/CT1100, Dymax Inc.) molding. The reflecting surfaces of the prism were maintained free of epoxy to ensure full total internal reflection. Figure 1 shows a diagram of the fiber-optic esophageal probe.

The probe was connected at the proximal end to a processing system consisting of a box containing LED light

sources and a photodiode. The LEDs, of peak emission wavelength 660 nm (red) and 850 nm (infrared), were coupled to one fiber using a bifurcated optical fiber assembly, while the other fiber was coupled to the photodiode. The LED wavelengths were chosen to be similar to those used in conventional pulse oximeters. The LEDs were driven at a duty cycle of 25% with forward current in the ‘on’ condition of 25 mA and 14 mA for red and infrared respectively, yielding an estimated total radiant flux of 1.5 mW and 2.5 mW respectively. The photodiode had a sensitivity rating of 70  $\mu\text{A}/\text{mW}/\text{cm}^2$ . The box also contained current sources for the LEDs, and a signal processing system. This was interfaced to a 16-bit data acquisition card (National Instruments Inc. Austin, TX, USA) installed into a notebook computer, which recorded the signals acquired from the tissue.

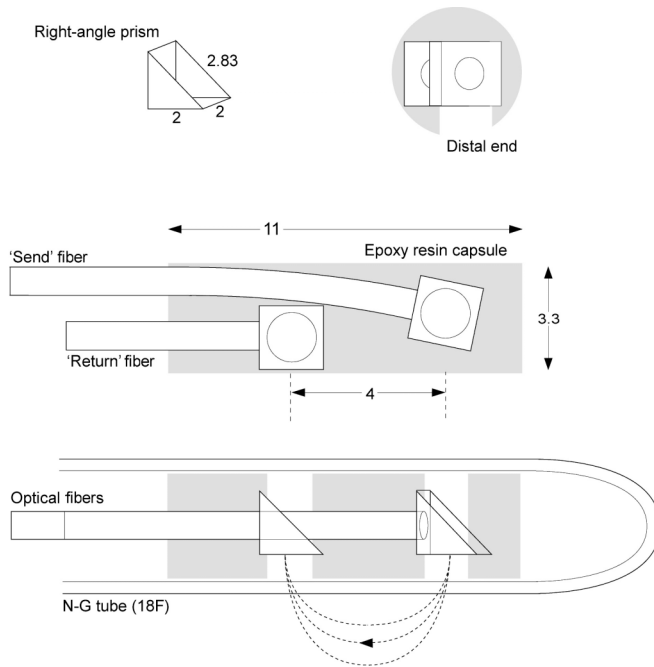

Fig. 1. Diagram of the fiber-optic esophageal oximetry probe. The nasogastric tube (N-G tube) is also shown in the lower image. All dimensions are in millimetres.

The probe was designed to be inserted into an 18 French gauge nasogastric tube (N-G tube). The N-G tube keeps the probe isolated from body fluids, so the probe may be re-used with a new N-G tube without the risk of cross-contamination between patients. The N-G tube has two perforations close to the distal end, which were blocked using a silicone bung prior to use. As a further precaution, the probe itself was decontaminated in a 70% propan-2-ol solution between patients. The tube was also marked using a non-toxic sterile permanent marker at 5 cm intervals to enable accurate positioning in the esophagus.

## B. Patients

The study was approved by the local Research Ethics Committee, and permission was given to conduct the study in 20 patients. The instrumentation was also approved for safety by the Medical and Healthcare Products Regulatory Agency (MHRA). Patients undergoing minor general surgical procedures requiring tracheal intubation and ventilation were deemed suitable for this study. Adult patients aged (18-70) and deemed ‘low risk’ by the American Society of Anesthesiologists (score of 1-3) were identified from the elective operating lists at Barts and The London NHS trust. Any patients in whom difficulty or increased risk of probe placement was anticipated, were excluded.

## C. Measurements

After induction of anesthesia and immediately after tracheal intubation, the probe contained within a sterile N-G tube was inserted into the esophagus by the anesthesiologist, via the patient’s mouth, under direct vision with a laryngoscope. The tip of the probe was placed at a depth of 35 cm in the esophagus as measured from the front incisors. Once the probe was in position, the light sources were switched on and signals recorded for 100 seconds. The probe was then withdrawn 5 cm at a time and signals recorded for a further 100 seconds at each position until the probe was at a depth of 15 cm. The arterial oxygen saturation was measured using a commercial finger pulse oximeter (Datex-Ohmeda, Helsinki, Finland). The probe was removed at the end of the measurement period, before the patient was moved from the anesthetic room to the operating theatre, and surgery commenced. Each patient was reviewed post-operatively, to check for any adverse events.

## D. Signal processing

The PPG (AC signal) was separated from the total intensity (AC+DC) signal using filters incorporated into the measurement circuitry. The PPG signal was normalized by dividing the signal by the simultaneously recorded AC+DC signal. The peak-to-peak amplitudes of the normalized PPG signals were calculated for each heart-beat using a peak and valley detection algorithm incorporated into a LabVIEW virtual instrument. The mean value of  $R_R$  for each data stream was calculated mean peak to peak amplitudes of the two PPG signals thus:

$$R_R = \frac{\sum_{i=1}^n A_{i,R}}{n} \bigg/ \frac{\sum_{i=1}^n A_{i,IR}}{n} \quad (1)$$

where the  $A_{i,R}$  and  $A_{i,IR}$  are the peak-to-peak amplitudes of the  $i$ th red and infrared PPG cycle in the data stream respectively and  $n$  is the total number of PPG cycles (heartbeats) in the data stream. The ratio-of-ratios  $R_R$  was thus averaged over a finite time period. The mean value of

$R_R$  was used to estimate the arterial oxygen saturation ( $SpO_2$ ) by substituting in the equation

$$SpO_2 = 110 - 25R_R \quad (2)$$

which is a linear approximation to an empirically determined calibration curve, obtained from measurements in healthy volunteers [9]. It should be noted that this equation was derived using a measurement system utilising a 940 nm infrared light source. As the present system uses an 850 nm LED, some error in estimation should be expected. However as no other equation is available, Equation (2) may be used to produce an approximate estimation of oxygen saturation.

### III. RESULTS

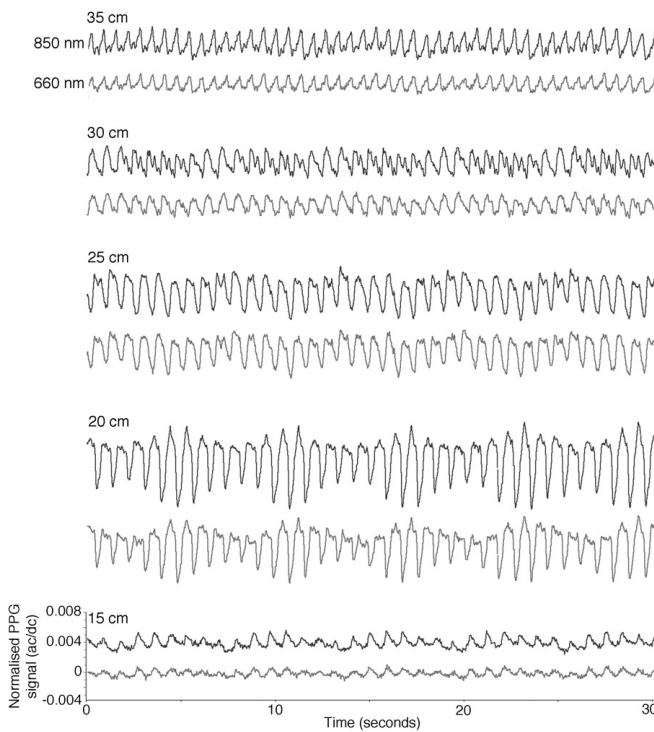

Fig. 2. 30-second samples of the normalized PPG waveforms obtained at each measurement depth. All traces are plotted on the same vertical scale.

Signals were successfully obtained from 19 patients, with one failure attributable to a technical fault. Figure 2 shows 30-second samples of the waveforms obtained at each depth for one patient. The dominant periodic feature occurs at a frequency consistent with the cardiac frequency, but the waveform also contains a low frequency modulation at about 0.18 Hz, equal to the frequency of artificial ventilation. The modulation affects the position of the peaks and ‘valleys’ i.e. the waveform’s peak-to-peak amplitude and the position of the ‘baseline’ is modulated. It can be seen that the morphology of the PPG waveform varies with varying depth of measurement. As well as the change in amplitude with depth, the ventilator modulation varies in amplitude relative to the periodic cardiac variation. Between 35 and 25 cm

there is significant baseline modulation but at depths of 20 cm or less there also appears to be modulation of the peak-to-peak amplitude.

Figure 3 shows a bar graph of the mean ( $\pm$ SD) of the normalized AC PPG amplitudes at red and infrared wavelengths at the five monitoring depths for all patients. The AC signals in the mid to lower esophagus (depths of 20 cm or greater) have significantly larger mean amplitudes at both wavelengths than those in the upper esophagus (15 cm). The maximum mean esophageal amplitude for each wavelength occurs at the depth of 20 cm.

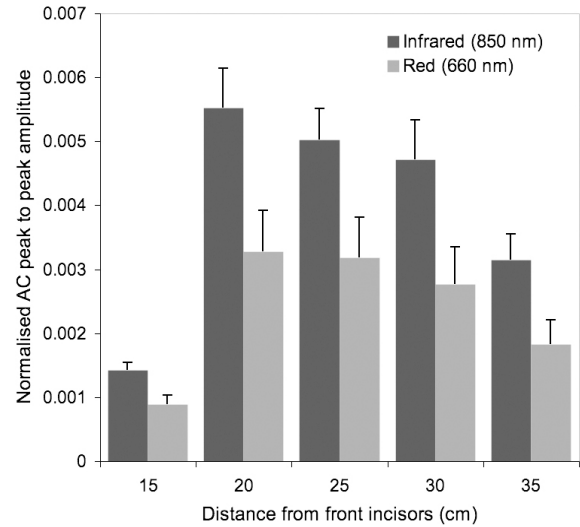

Fig. 3. Bar chart showing normalized mean ( $\pm$ SEM) peak-to-peak amplitude of normalized AC red and infrared signals measured from the esophagus in 19 patients.

The amplitudes of the red and infrared normalized PPG signals obtained at 15 cm were significantly smaller ( $P < 0.001$ ) than those obtained at all other depths, as evaluated by a paired Student’s t-test. There was no significant difference between amplitudes at other adjacent depths (i.e. 20–25 cm, 25–30 cm and 30–35 cm). To compare the signals between patients, a ‘best’ depth was chosen for each patient, i.e. the depth at which the infrared PPG amplitude was greatest, found by manual measurement of the amplitudes from printouts of the PPG waveforms. Table 1 summarises several variables derived from the signals for each patient obtained at the ‘best’ depth. It can be seen that even if the largest PPG amplitudes obtained for each patient are compared, there is considerable variability in the values of the amplitudes. The mean ratio-of-ratios for each patient (at the best depth) was also calculated from the PPG amplitudes, using Equation (1) and the estimated oxygen saturation calculated using Equation (2). The mean value ( $\pm$ SD) of oxygen saturation is 94.0% ( $\pm$  4.0%) for all patients ( $n = 19$ ). The arterial oxygen saturation recorded from the finger with the commercial pulse oximeter was in the range 98-100% for all 19 patients.

TABLE II  
VARIABLES DERIVED FROM PPG SIGNALS OBTAINED AT THE  
'BEST DEPTH' IN THE ESOPHAGUS

Pat. #	'Best' depth (cm)	Normalized PPG amplitudes		Mean SpO <sub>2</sub> (%)
		Red (/10 <sup>-3</sup> )	Infrared (/10 <sup>-3</sup> )	
1	30	10.7	14.0	90.9
2	20	11.6	16.8	92.7
3	30	1.03	2.74	100.6
4	25	7.14	6.86	84.0
5	25	16.5	24.8	93.4
6	25	4.94	12.4	100.0
7	30	3.72	9.33	100.0
8	25	4.82	6.52	91.5
9	20	3.22	5.58	95.6
10	35	2.68	4.16	93.9
11	30	4.85	8.21	95.2
12	35	3.98	5.51	91.9
13	30	3.73	7.80	98.0
14	30	4.14	6.68	94.5
15	25	2.57	3.91	93.6
16	25	3.66	6.78	96.5
17	20	5.59	8.59	93.7
18	25	6.08	7.95	90.9
20	25	1.67	1.99	89.0

#### IV. DISCUSSION

These results show that reliable photoplethysmographic signals may be obtained from the esophageal wall. The acquired signals showed different morphology and amplitudes, depending on the depth of the monitoring site. The measurements suggest that the greatest amplitude signals, and therefore probably the most suitable measuring site, is 20-30 cm from the teeth. Kyriacou et al compared PPG signals at the same depths as these studies, but using a non-fiber-optic probe. Their findings were similar; statistically significant differences between the PPG amplitudes in the upper esophagus (15 cm) and the amplitudes at all other depths at the infrared wavelength were found. This was also true for the red wavelength except that no significant difference between the amplitudes at the depths of 15 cm and 35 cm was seen [10].

In this study the value of the mean oxygen saturation of  $94 \pm 4.0\%$  was lower than that recorded from the finger using the commercial pulse oximeter. The slight negative bias may be attributable to the use of an algorithm (Equation 2) for calculation the SpO<sub>2</sub> which was developed from experimental measurements using transmittance mode probes on a different measurement site (the finger rather than the esophagus), and for a different infrared wavelength. Kyriacou et al. found their esophageal measurements to be on average 6.5% lower than those measured from a commercial finger pulse oximeter [1].

Another potential source of inaccuracy is possible mechanical artifact induced by the patients' heartbeat and ventilation due to the proximity of the probe to the heart and lungs. It has been observed that the PPG signals are sensitive to movement of the fiber tips relative to the tissue surface as well as movement of the fibers themselves. It may be supposed that a periodic (AC) modulation could be induced in the detected signals with cardiac and respiratory frequency. It may also be supposed that this induced movement modulation would be similar in magnitude for both wavelengths so the calculated ratio-of-ratio (normally < 1 for arterial blood) would be higher than in the case with no movement, most likely producing an underestimation of the reported oxygen saturation.

The esophageal measurements were made with the aim of investigating whether PPG signals could be obtained from internal vascularized tissue using a fiber-optic probe. Other than by pulse oximetry (which is not considered a 'gold-standard' method), accurate measurements of the arterial and venous oxygen saturations were not recorded, so further analysis of oxygen saturation in these patients was not deemed appropriate at this stage. The esophageal measurements however, demonstrate that PPG signals may be reliably obtained from internal tissue using a reflectance mode fiber-optic probe.

#### REFERENCES

- [1] P. A. Kyriacou, A. R. Moye, D. M. Choi, R. M. Langford, and D. P. Jones, "Investigation of the human esophagus as a new monitoring site for blood oxygen saturation," *Physiol Meas*, vol. 22, pp. 223-32, Feb 2001.
- [2] P. A. Kyriacou, A. R. Moye, A. Gregg, D. M. Choi, R. M. Langford, and D. P. Jones, "A system for investigating esophageal photoplethysmographic signals in anaesthetised patients," *Med Biol Eng Comput*, vol. 37, pp. 639-43, Sep 1999.
- [3] P. A. Kyriacou, S. Powell, R. M. Langford, and D. P. Jones, "Investigation of esophageal photoplethysmographic signals and blood oxygen saturation measurements in cardiothoracic surgery patients," *Physiol Meas*, vol. 23, pp. 533-45, Aug 2002.
- [4] P. A. Kyriacou, S. L. Powell, D. P. Jones, and R. M. Langford, "Evaluation of esophageal pulse oximetry in patients undergoing cardiothoracic surgery," *Anaesthesia*, vol. 58, pp. 422-7, May 2003.
- [5] S. K. Pal, P. A. Kyriacou, S. Kumaran, S. Fadheel, R. Emamdee, R. M. Langford, and D. P. Jones, "Evaluation of esophageal reflectance pulse oximetry in major burns patients," *Burns*, vol. 31, pp. 337-41, May 2005.
- [6] P. A. Kyriacou, A. Wardhaugh, D. P. Jones, R. M. Langford, and A. J. Petros, "Investigation of photoplethysmographic signals in neonatal and paediatric patients," *Intensive Care Medicine*, vol. 28 (Suppl. 1), 2002.
- [7] J. P. Phillips, R. M. Langford, P. A. Kyriacou, and D. P. Jones, "Preliminary evaluation of a new fiber-optic cerebral oximetry system," *Physiological Measurement*, vol. 29, pp. 1383-1396, December 2008 2008.
- [8] I. P. West, R. Holmes, and G. R. Jones, "Optical fiber based pulse oximeter for monitoring in magnetic resonance scanners," *Proceedings of SPIE - the International Society for Optical Engineering*, vol. 2360, pp. 94-97, 1994.
- [9] J. Moyle, *Pulse Oximetry (Principles and Practice)*, 2nd ed. London: BMJ Books, 2002.
- [10] P. A. Kyriacou, S. Powell, R. M. Langford, and D. P. Jones, "Esophageal pulse oximetry utilizing reflectance photoplethysmography," *IEEE Trans. Biomed. Eng.*, vol. 49, pp. 1360-8, Nov 2002.