



City Research Online

City St George's, University of London

Citation: Huo, B. Y. & D'Mello, C. (2013). Push-out tests and analytical study of shear transfer mechanisms in composite shallow cellular floor beams. *Journal of Constructional Steel Research*, 88, pp. 191-205. doi: 10.1016/j.jcsr.2013.05.007

This is the accepted version of the paper.

This version of the publication may differ from the final published version. To cite this item please consult the publisher's version.

Permanent repository link: <https://openaccess.city.ac.uk/id/eprint/14018/>

Link to published version: <https://doi.org/10.1016/j.jcsr.2013.05.007>

Copyright and Reuse: Copyright and Moral Rights remain with the author(s) and/or copyright holders. Copies of full items can be used for personal research or study, educational, or not-for-profit purposes without prior permission or charge, unless otherwise indicated, provided that the authors, title and full bibliographic details are credited, a hyperlink and/or URL is given for the original metadata page and the content is not changed in any way. For full details of reuse please refer to [City Research Online policy](#).

Push-out Tests and Analytical Study of Shear Transfer Mechanisms in Composite Shallow Cellular Floor Beams

Bing Y. Huo, Cedric A. D'Mello *

School of Engineering and Mathematical Sciences, City University London, Northampton Square, EC1V 0HB, UK

* Corresponding author. Tel.: +44 207 040 8161; fax: +44 207 040 8570.

E-mail address: C.A.D'Mello@city.ac.uk (Cedric D'Mello).

Abstract

The shear transferring mechanisms of composite shallow cellular floor beams are different with the conventional headed shear studs, and have not been investigated previously. This paper presents the experimental and analytical studies of the shear transferring mechanisms with the aims to provide information on their shear resistance and behaviour. The composite shallow cellular floor beam is a new type of composite floor beam consists of an asymmetric steel section with circular web openings and concrete slabs incorporated between the top and bottom flange. The unique feature of the web openings allows tie-bars, building services and ducting to pass through the structural depth of the floor beam, creating an ultra-shallow floor beam structure. The shear connection of the composite shallow cellular floor beam are formed innovatively by the web openings, as the in-situ concrete passes through the web openings may or may not include the tie-bars or ducting to transfer the longitudinal shear force. In total, 24 push-out tests were carried out to investigate the shear connection under the direct shear force. The effect of loading cycles on the shear connection was also investigated. The failure mechanisms of the shear connection were extensively studied, which had led to the development of a calculation method of shear resistance for the shear connection.

Keywords: shear transfer; shear connection; composite floor beam; web opening; push-out test; loading cycle; failure mechanism; analytical study.

1. Introduction

For conventional downstand composite beams or composite floor beams, i.e. Slimflor or Asymmetric Slimflor Beams, the thickness and width of the top flange increase with the increase of span; this often results in the steel sections being heavier than required [1]. A new type of floor beam, the composite shallow cellular floor beam, is commercially developed by Westok Limited under the trade mark of Ultra Shallow Floor Beam. The steel section of the composite shallow cellular floor beam is fabricated by welding two highly asymmetric cellular tees together along the web. Regularly spaced openings are formed on the web post. The top and bottom tees are cut from different parent sections. The weight of the steel section is reduced by having a smaller top tee. The moment resistance of the composite beam is optimized by having a bigger bottom tee. The precast floor units or profiled steel decking sit on the bottom flange, creating a shallow floor construction system [2], as illustrated in Fig. 1.

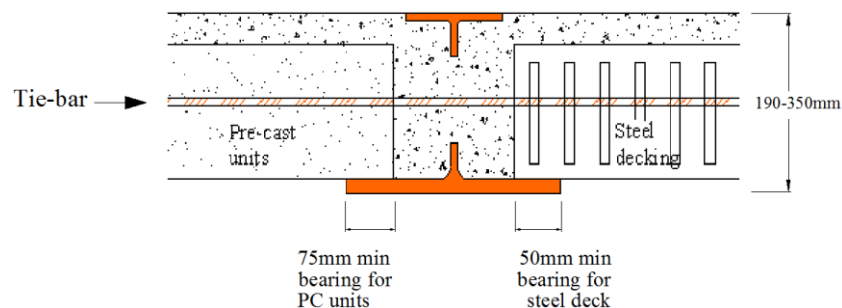

Fig. 1. Schematic drawing of the composite shallow cellular floor beam [2]



(a)



(b)

Fig. 2. Applications of the composite shallow cellular floor beam with (a) profiled steel decking (b) precast floor units (courtesy of ASD Westok Limited)

The circular web openings of the composite shallow cellular floor beams provide passage for the reinforcing tie-bars, building services and ducting through the structural depth, minimising the overall floor depth. The construction applications with different floors structures are depicted in Fig. 2. A partial encasement is created around the steel section. The in-situ concrete fills the web openings when the floors are being cast. The concrete infill combines with or without the additional elements, i.e. tie-bar or ducts, to form the unique shear connection transferring the longitudinal shear force. The studies presented in this paper have provided information on the shear resistance and behaviour of the shear connection.

A series of push-out tests consisting of 24 full-scale test specimens were performed to investigate the shear connection under the direct longitudinal shear force. The test specimens were designed to represent the actual configuration and shear behaviour of the shear connection. The set up and testing procedures of the push-out tests were designed to create desired loading conditions and also to be in compliance with Eurocode 4 (EN1994-1-1:2004) [3]. The results of the push-out tests were analysed with emphasis on the failure mechanisms of the shear connection. A calculation method for the shear resistance of the shear connection was developed based on the mathematical analysis of the test results.

2. Shear transferring mechanisms

The most commonly used shear transferring device, or shear connection, in both building and bridge constructions is the headed shear studs. The shear transferring mechanisms of the composite shallow cellular floor beams are different with the headed shear studs, are formed innovatively by the web openings of the steel section. There are four main types of shear connection used for the composite shallow cellular floor beams; they are: concrete-infill-only, tie-bar, ducting and web-welded stud shear connection.

The concrete-infill-only shear connection is formed as the in-situ concrete completely fills the web openings without any additional element, i.e. tie-bar or ducting. The concrete infill elements interact with the web post transferring the longitudinal shear force, as illustrated in Fig. 3 (a). This shear transferring mechanism is called concrete-infill-only shear connection.

One of the functions of the tie-bars used in the composite shallow cellular floor beams is to provide the tie force for the concrete slabs on both sides of the web post. Generally, high yield tie-bars of Ø16mm with 1m length are used to pass through every alternative web openings, as illustrated in Fig. 3 (b). However, in the situation of the tie-bars is constrained to be less than 1m; then two of Ø12mm tie-bars are used instead of one Ø16mm tie-bar, so that adequate anchorage resistance is provided. The in-situ concrete fills the web openings with the tie-bars to form the tie-bar shear connection. The combination of the concrete infill element and tie-bar interacts with the web post transferring the longitudinal shear force.

The ducting used to pass through the web openings for building services has smaller diameter than that of the web openings. The voids between the web opening and ducting are filled by the in-situ concrete. The concrete infill combines with the ducting to resist the longitudinal shear force, as illustrated in Fig. 3 (c). This shear transferring mechanism is called ducting shear connection.

The headed shear studs welded on the web post of the top tee, as shown in Fig. 3 (d), is to provide additional shear resistance for the composite shallow cellular floor beam in the region of high shear. The studs and concrete infill elements simultaneously transfer the longitudinal shear force. This type of shear transferring mechanism is called web-welded stud shear connection.

Apart from the above four shear transferring mechanisms, the shear bond mechanism also applies in the composite shallow cellular floor beams. The shear bond mechanism is

essentially based on the bond resistance developed between the steel section and concrete slab. This paper presents the investigation of the shear bond behaviour under the direct longitudinal shear force.

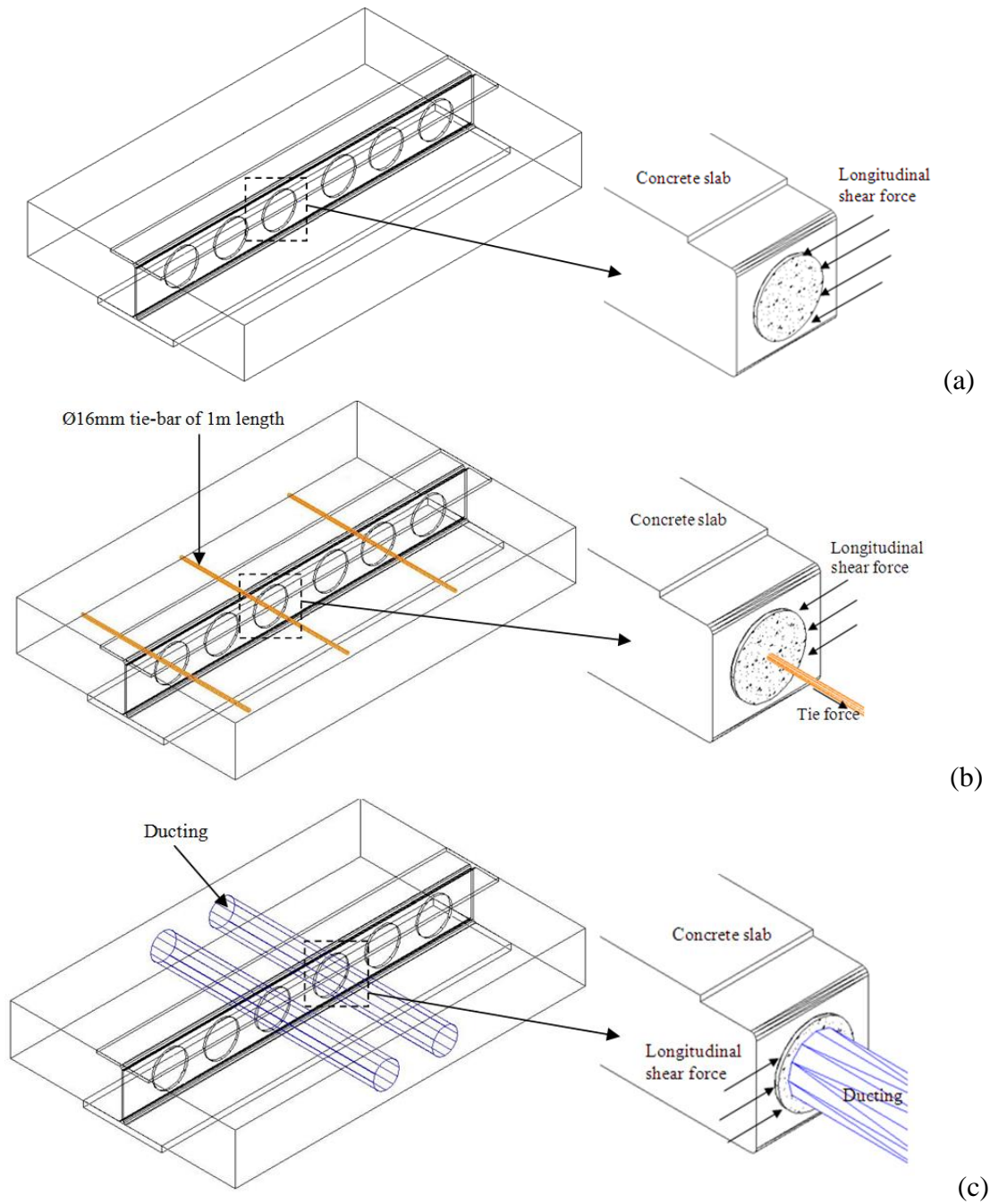

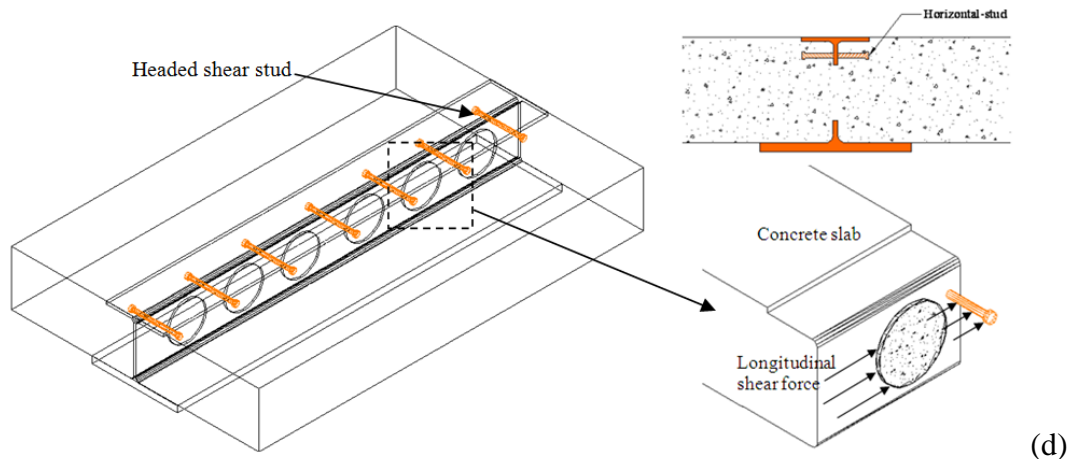

Fig. 3. Shear transferring mechanisms of the composite shallow cellular floor beam (a) concrete-infill-only shear connection (b) tie-bar shear connection (c) ducting shear connection (d) web-welded stud shear connection

3. Experimental investigation

3.1. Test specimens of push-out tests

The push-out tests had six test groups with a total of 24 full-scale test specimens, which were designed to investigate the concrete-infill-only, tie-bar, ducting and web-welded stud shear connection. The design principle for the test specimens was that the shear connection was subjected to the direct longitudinal shear force. And the shear connection was designed to represent its actual configurations in the practice. Each test group had four test specimens investigating a particular type of shear connection. The brief details of the test groups and its shear connection are summarised in Table 1.

In order to investigate the factors that would influence the shear resisting properties of the shear connection, the test specimens of test groups, T1, T2, T3 and T4, were designed to have two types of variables: diameter of web opening and concrete strength. There were two sizes of the web openings: $\text{Ø}150\text{mm}$ and $\text{Ø}200\text{mm}$. This enabled the study of the relationship between the web opening diameter and shear resistance of the shear connection. Two types of concrete were used to cast the concrete slabs, i.e. the normal concrete and fibre-reinforced

concrete. This enabled the study of the relationship between the concrete strengths and shear resistance of the shear connection. The tensile strength of the fibre-reinforced concrete was higher than that of the normal concrete with the same compressive strength. Details of the fibre reinforcement are presented in the section 3.1.1.

The test specimens of the test groups, T5 and T6, were modified based on the recommendations of the previous test groups, T1-T4, in order to further investigate the two most commonly used shear connection: concrete-infill-only and tie-bar ($\varnothing 16\text{mm}$) shear connection. Each of the two test groups had four identical test specimens. Loading cycles were introduced to investigate its effects on the shear resistance and behaviour of the concrete-infill-only and tie-bar ($\varnothing 16\text{mm}$) shear connection.

Table 1 Test groups and test specimens

Test Group	Shear connection	Variables of Specimens	Web Opening	Concrete Type	Specimen ^a
T1	Concrete-infill-only	• Diameter of web opening	$\varnothing 150\text{mm}$ ^b	Normal (<u>N</u>)	Tn-A-N
T2	Tie-bar ($\varnothing 12\text{mm}$)		(<u>A</u>)	Fibre (<u>F</u>)	Tn-A-F
T3	Ducting	• Concrete strength	$\varnothing 200\text{mm}$ ^c	Normal (<u>N</u>)	Tn-B-N
T4	Web-welded stud		(<u>B</u>)	Fibre (<u>F</u>)	Tn-B-F
T5	Concrete-infill-only	Identical specimens	$\varnothing 150\text{mm}$ ^b	Normal	T5-1, 2, 3, 4
T6	Tie-bar ($\varnothing 16\text{mm}$)				T6-1, 2, 3, 4

^a test specimens of test groups, T1-T4, were numbered in the pattern of Tn-A-N; test specimens of test groups, T5 and T6, were numbered in the pattern of T5-1.

^b web openings of $\varnothing 150\text{mm}$ were fabricated on 254x254x73UC.

^c web openings of $\varnothing 200\text{mm}$ were fabricated on 305x305x97UC.



Fig. 4. Steel section and test specimen of the push-out test

All test specimens consisted of a steel section and concrete slab flush with the steel flanges, as depicted in Fig. 4. Three web openings were fabricated on the web post of the steel section. The in-situ concrete passed through the web openings connecting the concrete slabs on both sides of the web post, to create the actual configuration of the shear transferring mechanisms. The steel section used for the push-out test specimens was universal column (UC). This was to prevent eccentric loading, which might be created if the actual asymmetric steel section for the composite shallow cellular floor beams was used.

In practice it is common to have steel wire mesh or rebar reinforcement in the concrete slab (this reinforcement does not pass through the web openings). The reinforcement could create unwanted confinement to the shear connection and restrain the transverse separation of the shear connection in the push-out tests. As the push-out tests were to investigate the shear connection solely subjected to the direct longitudinal shear force and in order to minimise the number of variables, this type of reinforcement was not included in the push-out test specimens.

The shear resistance and behaviour of the shear transferring mechanisms in the full-scale composite shallow cellular floor beam under the flexural bending tests has been further

investigated by the authors [4]. The results of the flexural tests are to be presented in the future publications.

In order to study the relationship between the shear resistance of the shear connection and diameter of the web opening, the steel sections were designed to have two diameters of the web openings, 150 and 200mm, which were perforated on the steel sections of 254x254x73UC and 305x305x97UC respectively. A steel plate of 20mm thick was welded on the top of the steel section to evenly spread the load.

The total width of the concrete slab was 600mm for test specimens of the test groups, T1-T4. The total width of the concrete slab was increased to 1m for test specimens of the test groups, T5 and T6. This was to accommodate the 1m length of the Ø16mm tie-bar used for tie-bar shear connection of the test group, T6. The reason to keep the width of concrete slab and all other geometries same between test specimens of T5 and T6 was to study the increase of shear resistance for the shear connection due to the additional Ø16mm tie-bar.

3.1.1 Fibre reinforcement

The fibre used for the fibre-reinforced concrete was synthetic fibre reinforcement, 40mm in length and with an aspect ratio of 90. The fundamental mechanism of the synthetic fibre was a mechanical action and not a chemical reaction between the fibre and concrete cement paste. As illustrated in Table 2, the concrete strength tests carried out by the authors demonstrated the tensile strength of the fibre-reinforced concrete was higher than that of the normal concrete with the same compressive strength.

The dosage rate of the fibre reinforcement used for the push-out test specimens was 5.3kg/m^3 . In order to improve the workability of the fibre-reinforced concrete, superplasticizer was added into the mix. The slump of the fibre-reinforced concrete was increased from 50mm to 120mm as the design workability.

Table 2 Comparison of concrete strength between the fibre-reinforced and normal concrete

	Compressive strength (MPa)	Tensile strength (MPa)
Fibre-reinforced concrete	35	4.06
Normal concrete	35	3.26

3.2. Details of test specimens

The test specimens of test group, T1, represented the concrete-infill-only shear connection which had no other elements, i.e. tie-bar or ducting, passing through the web openings. The in-situ concrete completely filled the web opening. The test specimens were designed so that the load applied onto the steel section would be directly resisted by the concrete infill elements. Hence, the shear resistance and behaviour of the concrete-infill-only shear connection could be investigated. Each test specimen had three concrete-infill-only shear connection, as shown in Fig. 5.

In addition, shear bond behaviour was investigated through the specimens of test group T1 as no de-bonding grease was applied on to the steel sections. Hence, bond developed between the steel section and concrete slab. The design strength of the shear bond resistance was taken as 6.0N/mm^2 , which was justified by the full-scale test for the ASB section with raised pattern rolled into the top flange [5] [6]. The calculated shear bond resistance was lower than the predicted shear resistance of the concrete-infill-only shear connection. Shear bond failure was expected before the failure of the concrete-infill-only shear connection.

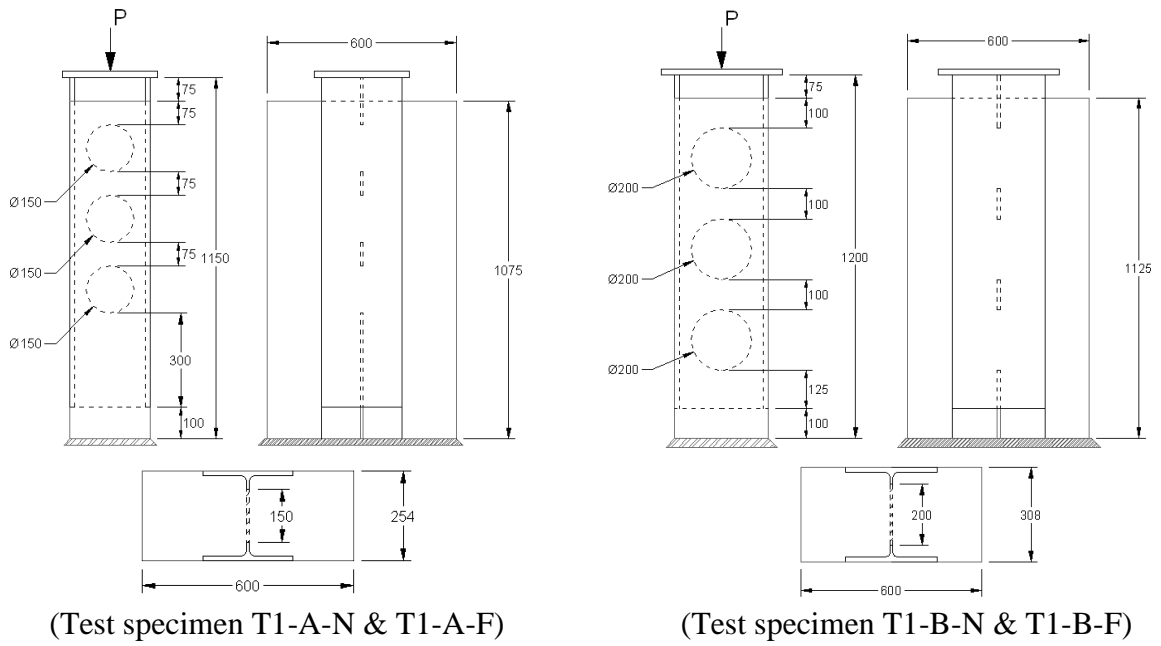

Fig. 5. Test specimen of test group, T1, concrete-infill-only shear connection

The tie-bar ($\text{Ø}12\text{mm}$) shear connection of the test group, T2, represented the practice of using two $\text{Ø}12\text{mm}$ tie-bars to pass through each web opening. Two tie-bars were positioned close to the perimeter of the web opening, as shown in Fig. 6. The top tie-bar within each web opening would be in direct contact with the movements of the steel section (or slips); hence, it would show the shear failure mode.

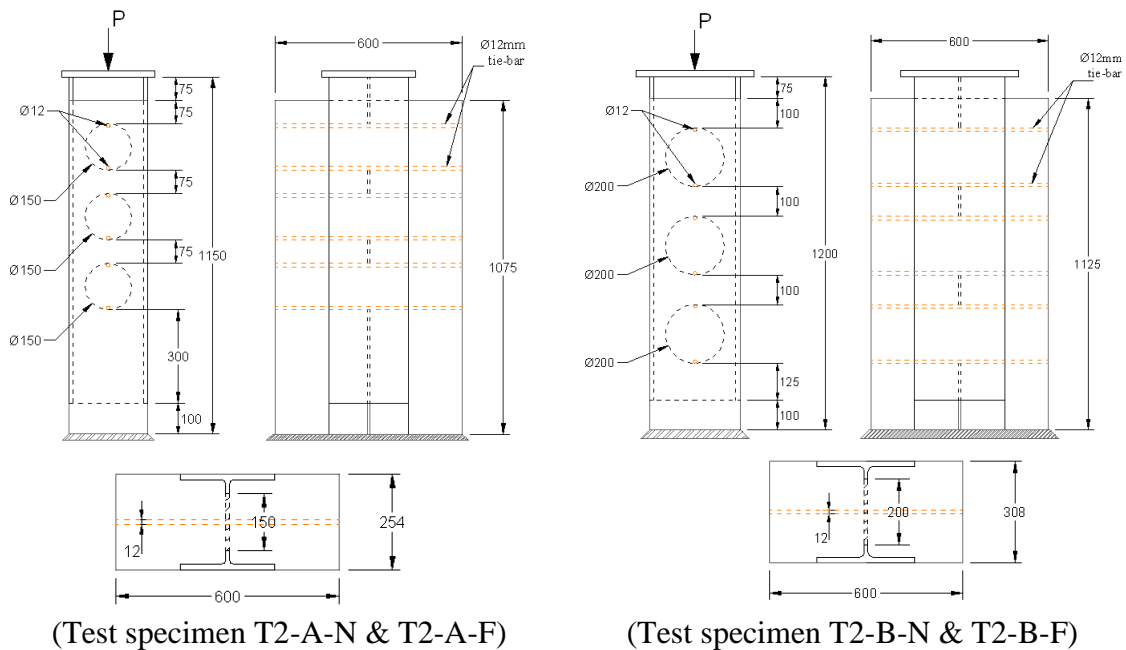

Fig. 6. Test specimen of test group, T2, tie-bar ($\text{Ø}12\text{mm}$) shear connection

The test specimens of the test group, T3, were designed to represent the configuration of the ducting shear connection used in the practice. Generally, the diameter of the ducting was smaller than that of the web openings, so that the voids between the ducting and web opening were filled by the in-situ concrete. The concrete infill combined with the ducting to resist the longitudinal shear force. For the test specimens, $\text{Ø}125\text{mm}$ ducting was used to pass through the web openings of $\text{Ø}150\text{mm}$, and $\text{Ø}150\text{mm}$ ducting was used to pass through the web openings of $\text{Ø}200\text{mm}$, as illustrated in Fig. 7. The ducting used for the test specimen was formed of 0.5mm thick galvanised steel sheets.

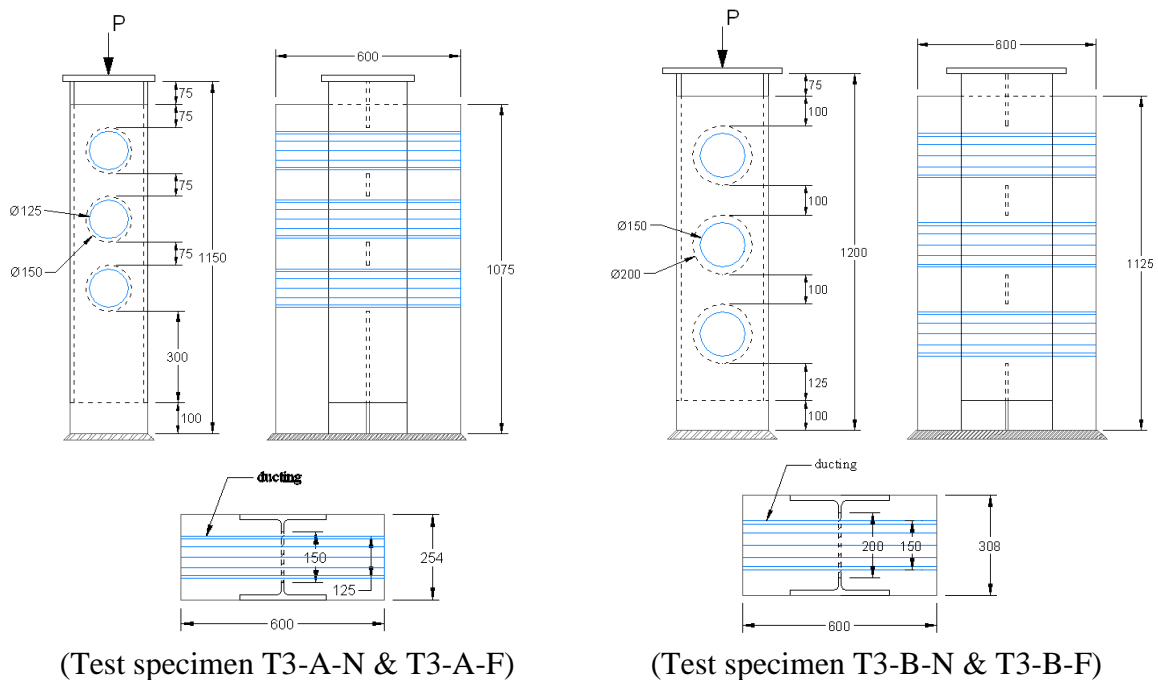

Fig. 7. Test specimen of test group, T3, ducting shear connection

The test specimens of the test group T4 comprised four headed shear studs welded symmetrically on each side of the web post, as illustrated in Fig. 8. This layout was different with the practice which had the studs welded only on the top tee, as shown in Fig. 3d. The symmetric layout design of the studs for the push-out test specimen was to prevent eccentric loading. The actual shear transferring mechanism of the web-welded stud shear connection was created in the push-out tests, as the concrete infill elements and shear studs would

simultaneously resist the longitudinal shear force. The diameter of the studs was 19mm and the after-welding height was 127mm.

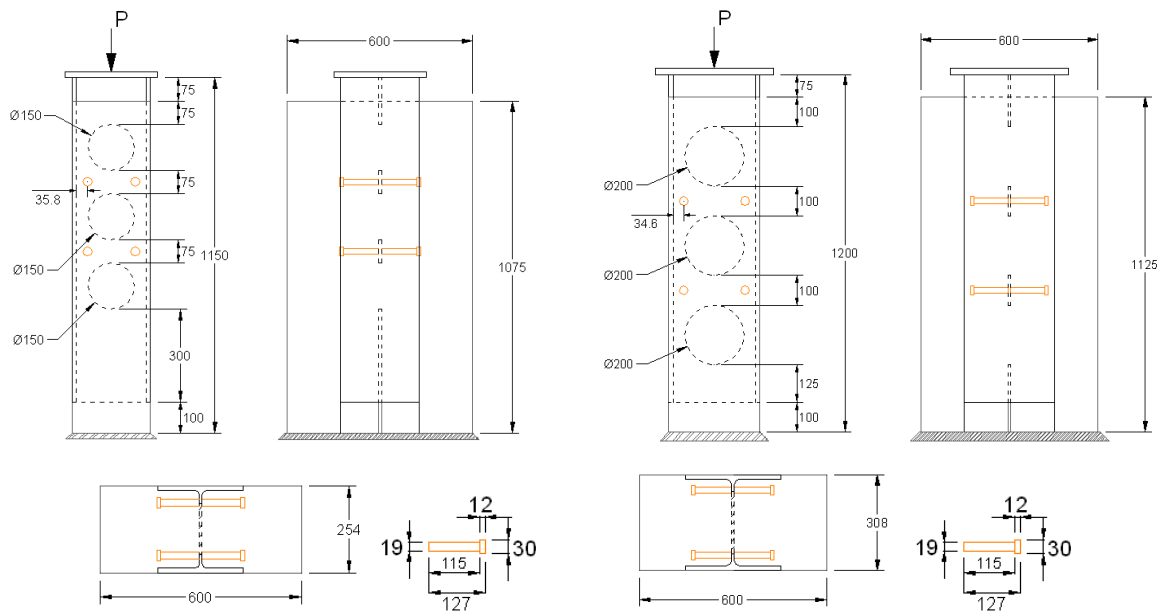

Fig. 8. Test specimen of test group, T4, web-welded stud shear connection

The test specimens of test group, T5, further investigated the concrete-infill-only shear connection, as illustrated in Fig. 9. The geometry properties of the test specimens were the same as those of the test group, T1, apart from the total width of the concrete slabs which was increased to 1m. The test specimens of test group, T6, investigated the tie-bar ($\text{Ø}16\text{mm}$) shear connection which had one $\text{Ø}16\text{mm}$ tie-bar passing through the centre of the web openings, as illustrated in Fig. 10.

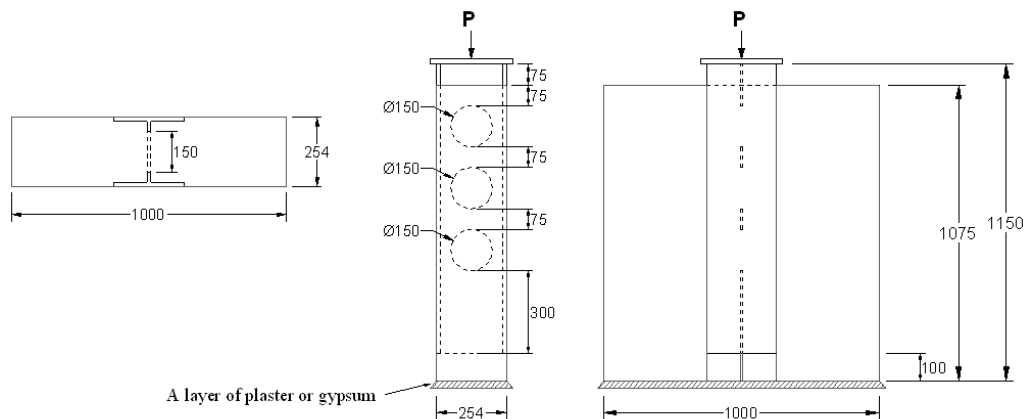

Fig. 9. Test specimen of test group, T5, concrete-infill-only shear connection

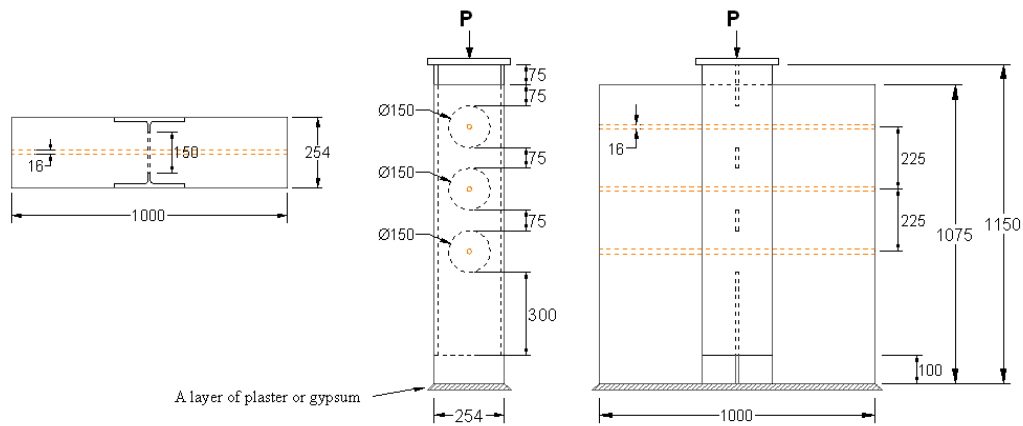

Fig. 10. Test specimen of test group, T6, tie-bar ($\text{Ø}16\text{mm}$) shear connection

3.3. Setup and testing procedures

The steel sections of all test specimens were applied with de-bonding grease before casting with concrete, apart from the steel sections for the test group, T1 (concrete-infill-only shear connection). The use of de-bonding grease was to prevent the development of bond between the steel and concrete. In order to investigate specifically the shear bond behaviour under direct longitudinal shear force, de-bonding grease was not applied to test specimens T1, concrete-infill-only shear connection. All push-out test specimens were cast in the Structure Laboratory of City University London.

The test specimens were cast vertically, the main reason being that of ease of casting. It was difficult to construct the mould for casting in horizontal position. Nevertheless, the concrete mix was designed with less flow and all test specimens were uniformly compacted to avoid any voids or segregation of the aggregates from cement paste. Examination of tested specimens showed that segregation of aggregates did not occur. The concrete strength specimens, cubes and cylinders, were prepared using the same batch of concrete for the push-out test specimens. All cubes, cylinders and specimens of push-out tests were cured under the same conditions, covered with wet sacked and plastic sheets.

A rig of 1900kN capacity was used for the push-out tests. Static monotonic loads were applied to the test specimens by two identical hydraulic jacks of 880kN capacity. Digital dial gauges were used to measure the slip and separations of the shear connection. Four dial gauges were used to measure the slip and separations of the shear connection. Four dial gauges were positioned on the top of the steel section measuring the slips in the vertical direction, as depicted in Fig. 11. And four dial gauges were positioned on both sides of the concrete slabs measuring the separations in the horizontal direction.

The push-out tests were carried out in accordance with Eurocode 4 [3]. The test specimens were settled onto a layer of plaster (gypsum) to create an even contact surface between the specimens and reaction platform. The push-out tests were load-controlled with monotonic loading applied onto the steel section; hence, incremental shear force was applied onto the shear connection. The specimens were tested until the destructive failure of the shear connection. One of the specimens for both test groups, T5 and T6, were applied with additional loading cycles of 25 times between 5-40% of the expected failure loads. The duration of all push-out tests was 2 hours on average.

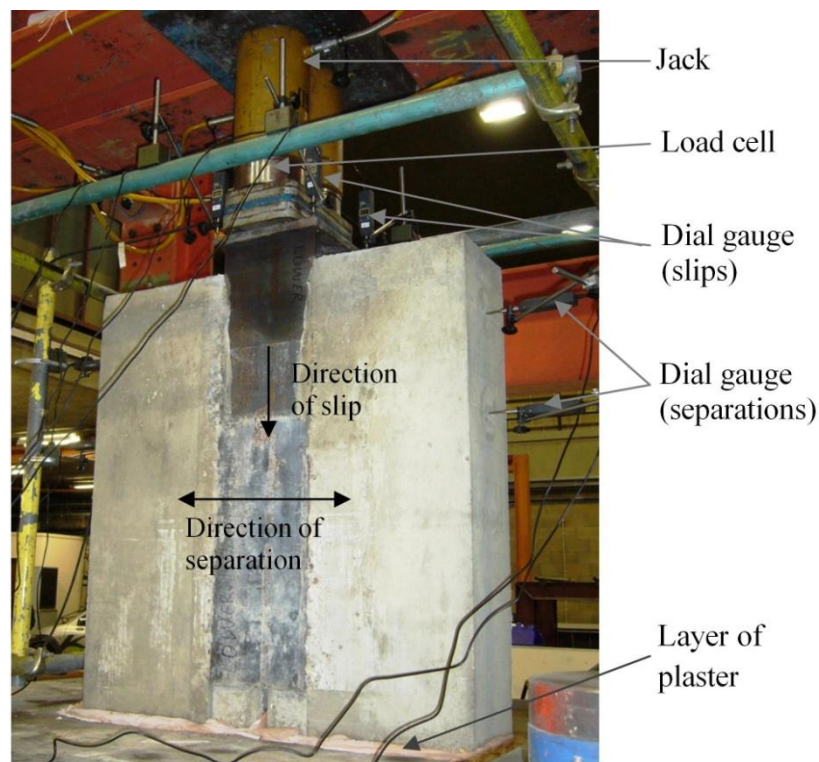

Fig. 11. Setup and instrumentations of the push-out tests

4. Test results

The results of push-out test are summarised in Table 3. The ultimate shear resistance of the shear connection, P_u , was obtained by dividing the ultimate load of the test specimen by the number of the shear connection. The slip capacity of the shear connection, δ_u , was the slip value at the load level dropped 10% below the ultimate load [3]. The concrete-infill-only and ducting shear connection showed no plastic slips after the ultimate loads were reached. Hence, their slip capacities, δ_u , were taken as the slip values at the ultimate load levels. The stiffness of the shear connection, K , was the linear stiffness of the load-slip curves. The test results showed that the additional elements, tie-bar and web-welded shear stud, significantly increased the shear resistance of the shear connection.

The relationships between the shear resistance of the shear connection and variables of web opening diameter and concrete strength were investigated in the push-out test groups of T1, 2, 3 & 4. The test results showed that, for the same type of the shear connection, the shear resistance of the shear connection increased with the increase of web opening diameter. This is demonstrated in the following comparisons, which are based on the same concrete strength.

- For the concrete-infill-only shear connection in test group T1, the failure loads of the specimens with $\varnothing 200\text{mm}$ web openings, T1-B-N & T1-B-F, were higher than that of the specimens with $\varnothing 150\text{mm}$ web openings, T1-A-N & T1-A-F, respectively.
- For the tie-bar ($\varnothing 12\text{mm}$) shear connection in test group T2, the failure loads of the specimens with $\varnothing 200\text{mm}$ web openings, T2-B-N & T2-B-F, were higher than that of the specimens with $\varnothing 150\text{mm}$ web openings, T2-A-N & T2-A-F, respectively.
- For the ducting shear connection in test group T3, the specimens of T3-B-N & T3-B-F with the $\varnothing 200\text{mm}$ web openings and $\varnothing 150\text{mm}$ ducting had a larger concrete infill (between the ducting and web opening) than the other two specimens of T3-A-N & T3-A-F. The test results demonstrated the relationship between the shear resistance of the

shear connection and the amount of concrete infill. The failure loads of specimens with bigger concrete infill, T3-B-N & T3-B-F, were higher than that of specimens with smaller concrete infill, T3-A-N & T3-A-F.

- For the web-welded stud shear connection in test group T4, the failure loads of the specimens with $\text{\O}200\text{mm}$ web openings, T4-B-N & T4-B-F, were higher than that of the specimens with $\text{\O}150\text{mm}$ web openings, T4-A-N & T4-A-F, respectively.

Another finding was that, for the same type of the shear connection, the shear resistance increased with the increase in concrete strength. This is demonstrated in the following comparisons, which are based on the same web opening diameter.

- For the concrete-infill-only shear connection in test group T1, the specimens with higher concrete strength, T1-A-F & T1-B-F, had higher failure loads than the specimens with lower concrete strength, T1-A-N & T1-B-N, respectively.
- For the tie-bar ($\text{\O}12\text{mm}$) shear connection in test group T2, the specimens with higher concrete strength, T2-A-N & T2-B-N, had higher failure loads than that of the specimens with lower concrete strength, T2-A-F & T2-B-F, respectively.
- For the web-welded stud shear connection in test group T4, the specimens with higher concrete strength, T4-A-N & T4-B-N, had higher failure loads than that of the specimens with lower concrete strength, T4-A-F & T4-B-F, respectively.

However, the ducting shear connection in test group T3 did not show that the failure load increased with the increase of concrete strength. This might be due to the fact that the amount of the concrete infill was much less than other types of shear connection and the difference in concrete strength was small between the specimens. Hence the effect of concrete strength was not entirely clear.

Each of test group T5 and T6 had four identical specimens investigating the concrete-infill-only and tie-bar ($\text{Ø}16\text{mm}$) shear connection, respectively. All geometries between the specimens of both test groups were the same. This was to study the increase of shear resistance due to the additional $\text{Ø}16\text{mm}$ tie-bar positioned through the centre of the web openings. By comparing the test results of test group, T5 and T6, the additional $\text{Ø}16\text{mm}$ tie-bars increased the shear resistance of the shear connection by 100%. The increase of shear resistance and slip capacity is also demonstrated in Fig. 18

The concrete-infill-only and ducting shear connection showed the moderate slips of 3-5mm in the push-out tests. In contrast, the tie-bar and web-welded stud shear connection showed the large slips of 8-16mm. All shear connection showed small values of separation, about 1mm, which indicated the strong tie resistance of all shear connection. The load-slip and load-separation curves obtained in the push-out tests were shown in Figs. 12 – 17. The load-slip curves represented the characteristic behaviour of the shear connection in response to the direct longitudinal shear force. The load-separation curves represented the tie-resisting behaviour of the shear connection to the longitudinal shear force.

Table 3 Results of the push-out tests

Shear connection	Specimen No.	f_{cu}^a (MPa)	f_{ct}^b (MPa)	Ultimate shear resistance P_u (kN)	Slip capacity δ_u (mm)	Stiffness K (kN/mm)
Concrete-infill-only	T1-A-N	56	4.53	118	2.85	41
	T1-A-F	58	4.85	131	4.09	40
	T1-B-N	56	4.53	362	4.92	74
	T1-B-F	58	4.85	397	7.7	62
Tie-bar (Ø12mm)	T2-A-N	54	4.54	309	16.0	45
	T2-A-F	52	4.07	305	15.5	49
	T2-B-N	55	4.54	390	14.7	50
	T2-B-F	52	4.07	372	12.2	47
Ducting	T3-A-N	55	3.91	47	2.07	31
	T3-A-F	52	3.89	50	1.45	35
	T3-B-N	55	3.91	125	3.37	37
	T3-B-F	52	3.89	137	3.21	43
Web-welded stud	T4-A-N	67	4.66	504	8.11	66
	T4-A-F	50	4.08	427	14.8	58
	T4-B-N ^c	67	4.66	--	--	70
	T4-B-F	50	4.08	497	14.4	49
Concrete-infill-only	T5-1	35	3.21	226	4.9	47
	T5-2	35	3.21	194	3.9	54
	T5-3	32	2.90	182	3.9	47
	T5-4	30	3.02	170	4.4	36
Tie-bar (Ø16mm)	T6-1	29	2.85	391	13.0	44
	T6-2	32	2.92	386	12.2	42
	T6-3	28	2.49	327	13.7	45
	T6-4	27	2.57	358	13.7	40

^a Mean cube compressive strength. ^b Mean cylinder tensile splitting strength.

^c Test specimen T4-B-N was not failed, as the capacity of the jacks was reached.

4.1. Behaviour analysis

Uniform slip behaviour of the concrete-infill-only shear connection was shown in the push-out tests among the test groups, T1 and T5. The shear connection demonstrated elastic slip behaviour until the rupture failure at the maximum loads without any plastic slip behaviour, as shown in Fig. 12 and 16. This brittle failure mode of the concrete-infill-only shear connection was due to the inherent brittle material properties of concrete, as the shear connection consisted of solely the concrete infill element. The test specimens, T1-A-F & T1-B-N, clearly demonstrated the failure of the shear bond under the direct longitudinal shear force, as sudden increase of slips occurred. However, the shear bond failure did not cause the entire failure of the shear connection, as elastic slip behaviour due to the infill resumed after the sudden initial slip increase.

Ductile slip behaviour of the tie-bar shear connection was shown by both test groups of T2 and T6, which had tie-bar $\text{\O}12\text{mm}$ and tie-bar $\text{\O}16\text{mm}$ shear connections, respectively. Both types of tie-bar shear connection demonstrated the elastic slip behaviour before started to show significant plastic slips, as illustrated in Fig. 13 and 17. The tie-bar ($\text{\O}12\text{mm}$) shear connection demonstrated sudden minor slip increase during the elastic slip behaviour. This was due to the local failure of the $\text{\O}12\text{mm}$ tie-bar, as the tie-bar was in direct contact with the slips of the steel section. However, the local failure of the tie-bar did not cause the entire failure of the shear connection, as the elastic slip behaviour resumed thereafter. After the maximum load was reached by the tie-bar ($\text{\O}12\text{mm}$) shear connection, the load levels dropped gradually with extensive slips.

The tie-bar ($\text{\O}16\text{mm}$) shear connection in test group T6 had an $\text{\O}16\text{mm}$ tie-bar passing through the centre of the web opening, as illustrated in Fig. 10. The push-out tests showed there was no local failure of the $\text{\O}16\text{mm}$ tie-bar (Fig. 17). This was mainly due to the fact that the $\text{\O}16\text{mm}$ tie-bar was positioned through the centre of the web opening and hence, direct

contact with the web post was avoided. The elastic slip behaviour was shown by the shear connection, and the ultimate load was sustained with large slips during the post-failure loading, as illustrated in Fig. 17. The mechanism of sustaining the shear force was further demonstrated during the post-failure unloading and re-loading of the test specimen T6-2. The slip behaviour of the shear connection indicated that the tensile strength of the Ø16mm tie-bar had become effective toward the overall shear resistance of the shear connection. It was also demonstrated that the 1m length provided adequate anchorage to the Ø16mm tie-bar, as there was no anchorage failure occurred in the push-out tests.

The slip behaviour of the ducting shear connection was elastic up to the ultimate load, as shown in Fig. 14. There were no plastic slips before the ultimate load was reached, but the rupture failure was not shown by the ducting shear connection. Large slips were induced after the ultimate load levels. The presence of the ducting reduced the attendance of brittle rupture failure, although the ducting itself could not provide much of the shear resistance.

The web-welded stud shear connection demonstrated the ductile slip behaviour, as shown in Fig. 15. Large plastic slips occurred before and after the ultimate load was reached. The destructive failure of the shear connection occurred after the load dropped to 85-93% of the ultimate load. The slip behaviour of the web-welded stud shear connection was very similar to that of the shear studs in the standard push-out tests [7]. This similar slip behaviour indicated that the additional studs directly influenced the slip behaviour of the web-welded stud shear connection, and also increased the ductility of the shear connection.

The separations of the shear connection were mainly due to the splitting of the concrete infill elements in the transverse direction. The slips of the shear connection were mainly due to the crushing of the concrete infill elements in the longitudinal shear direction. It was clearly shown by all four types of shear connection in the push-out tests that the separations or splitting of the shear connection occurred at the load levels when the slip behaviour

became nonlinear. This characteristic behaviour indicated that the shear resistance of the shear connection were contributed by both compressive and tensile splitting resistances of the concrete infill element.

4.2. Effects of loading cycles

One of test specimens in each test group of T5 and T6 was applied with additional loading cycles of 25 times between 5-40% of the expected failure loads. The effects of the loading cycles to the concrete-infill-only and tie-bar ($\text{Ø}16\text{mm}$) shear connection were investigated. The slip behaviour of both types of shear connection during the loading cycles was elastic, as shown in Figs. 19 and 20. The slip increase of both types of shear connection during the loading cycles was 0.18mm. It was due to the crushing of the concrete infill element by the direct longitudinal shear force during the loading cycles. The overall behaviour of the shear connection was not affected by the loading cycles, as the elastic slip behaviour was resumed thereafter. By analysing the slip increased over the loading cycles of 25 times, it was shown that the slip increased during the first three loading cycles was 8-10 times the slip increased during the last three loading cycles. The increase of slip was reduced with higher number of loading cycles. It was predicted that the slip increased by the loading cycles would reach a certain level as the number of loading cycles exceeded a certain limit.

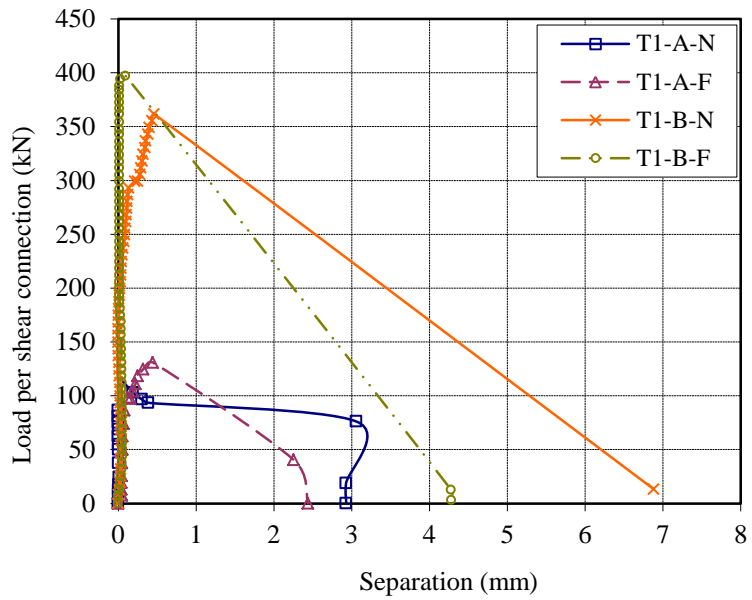
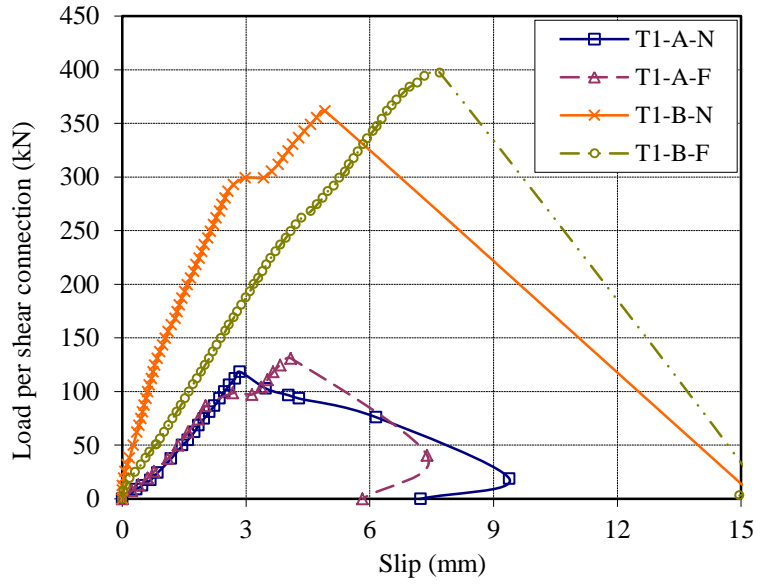

Fig. 12. Load-slip and load-separation curves of the concrete-infill-only shear connection in test group T1

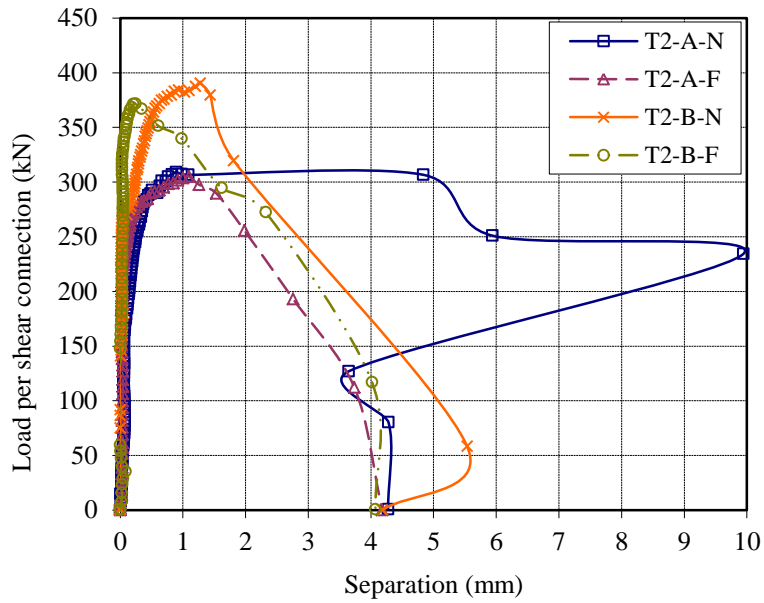
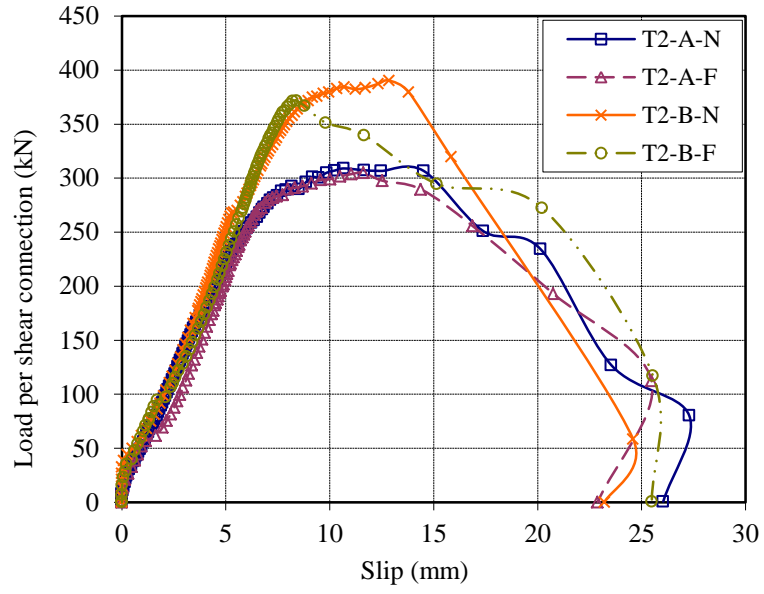

Fig. 13. Load-slip and load-separation curves of the tie-bar ($\text{\O}12\text{mm}$) shear connection in test group T2

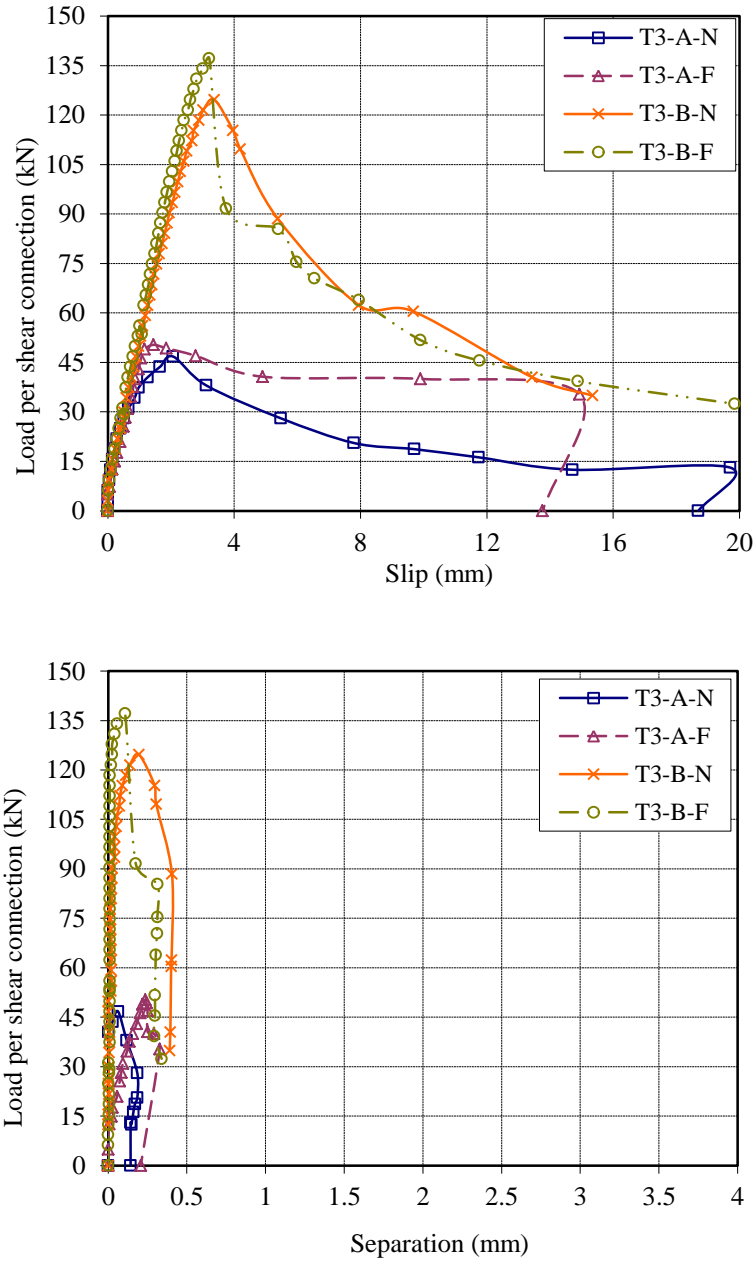

Fig. 14. Load-slip and load-separation curves of the ducting shear connection in test group T3

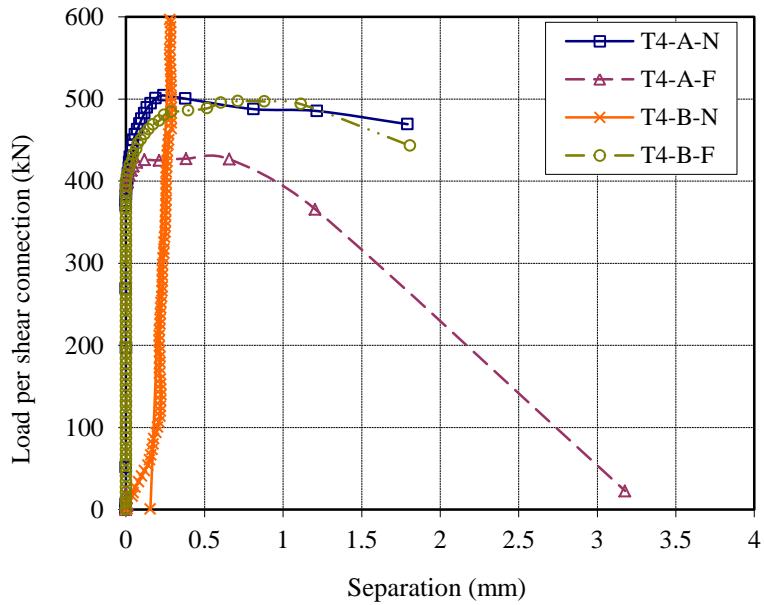
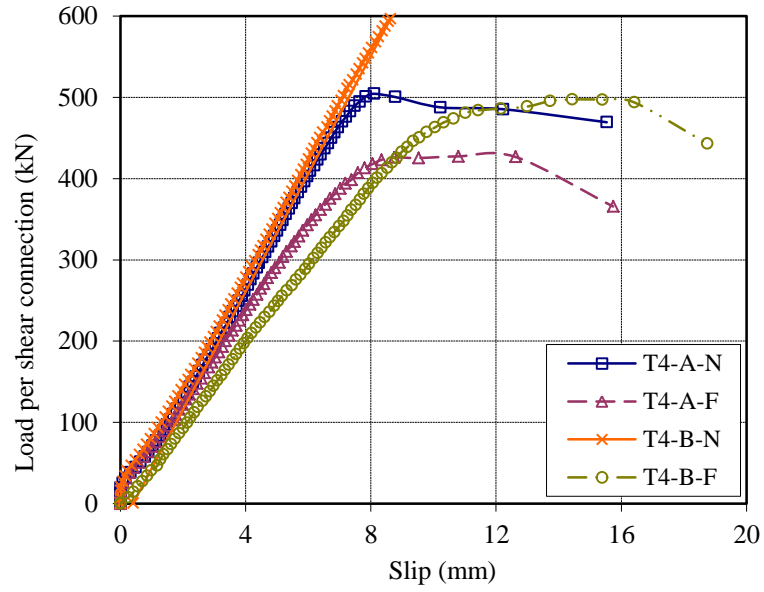

Fig. 15. Load-slip and load-separation curves of the web-welded shear connection in test group T4

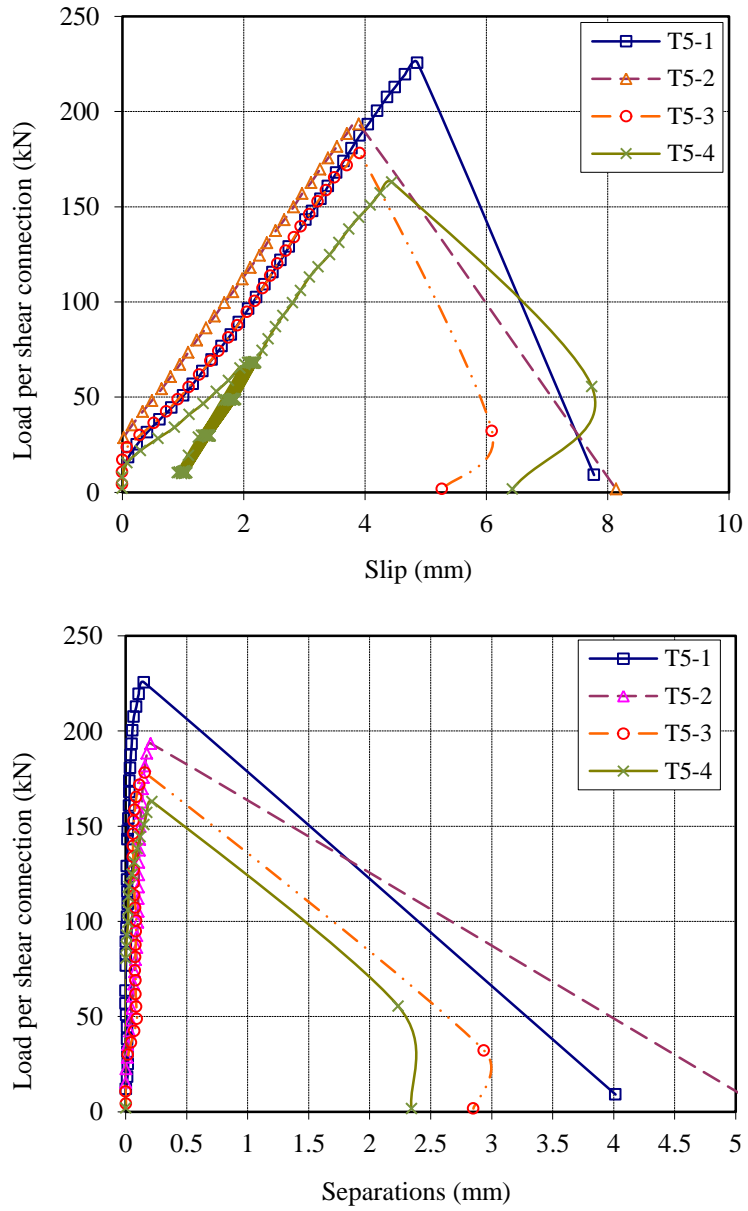

Fig. 16. Load-slip and load-separation curves of the concrete-infill-only shear connection in test group T5

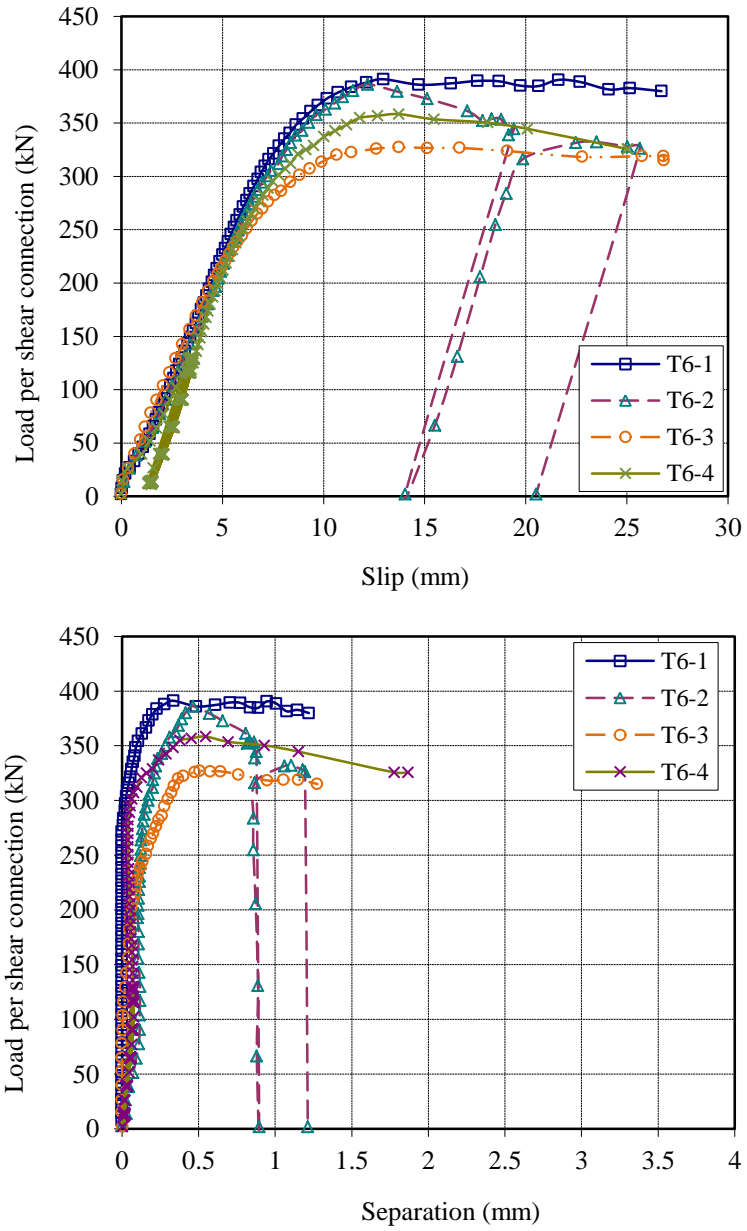

Fig. 17. Load-slip and load-separation curves of the tie-bar ($\text{\O}16\text{mm}$) shear connection in test group T6

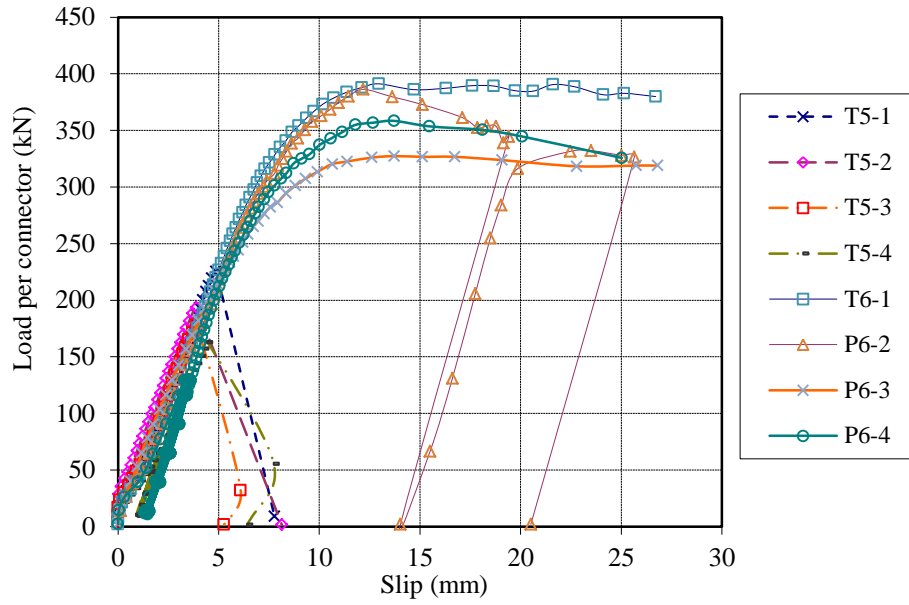
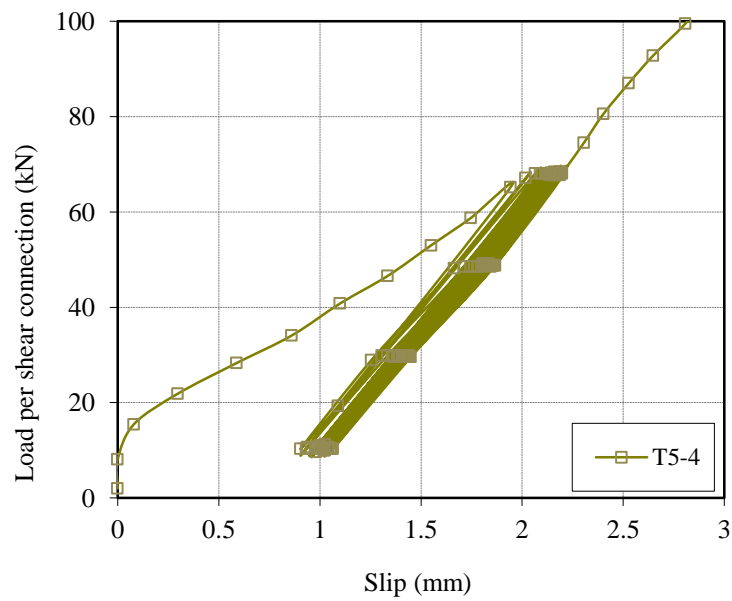

Fig. 18. Comparison of load-slip curves between concrete-infill-only (T5) and Ø16mm tie-bar (T6) shear connection



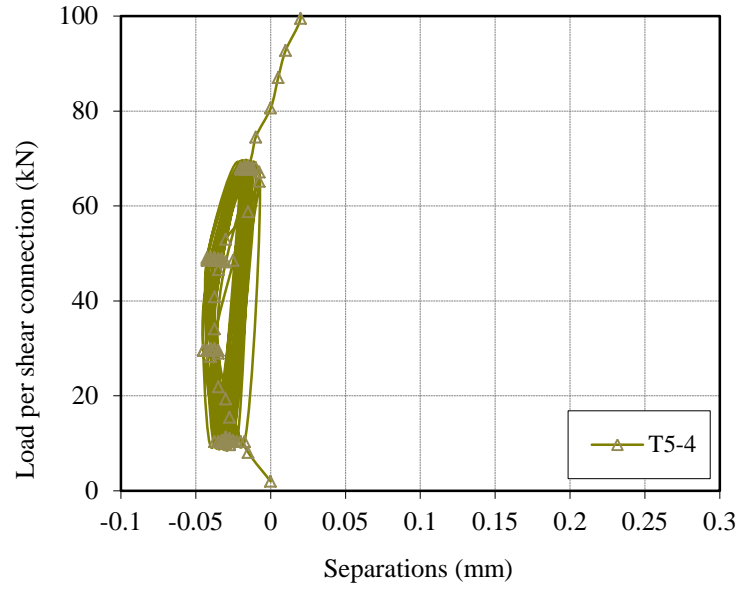
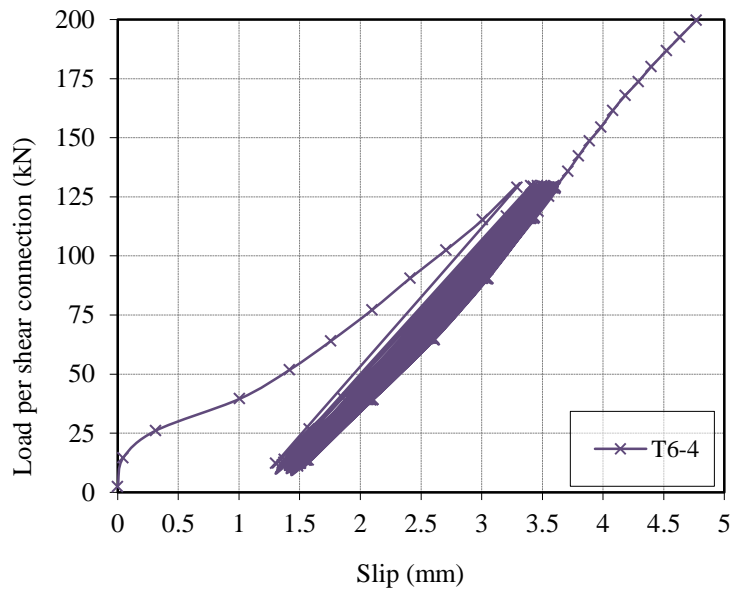

Fig. 19. Slip and separation response of the concrete-infill-only shear connection to the loading cycles



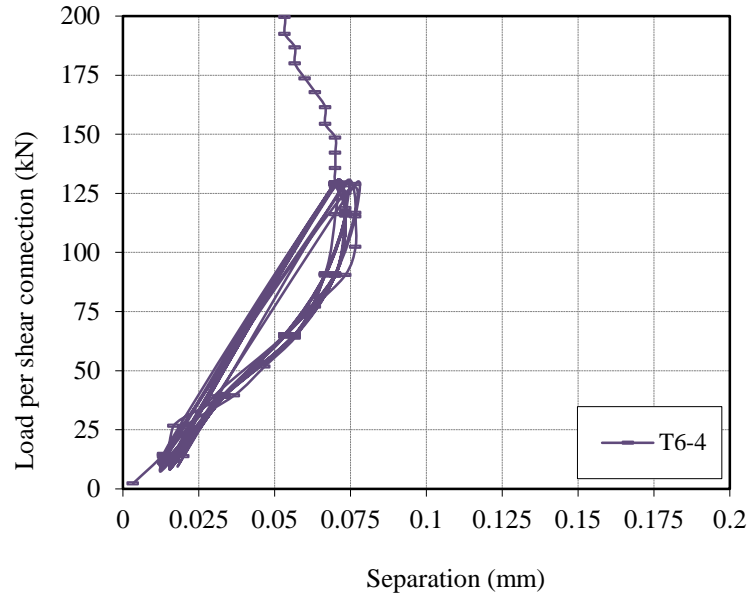

Fig. 20. Slip and separation response of the tie-bar (Ø16mm) shear connection

4.3. Failure mechanisms

The tested specimens were examined to study the failure mechanisms of the shear connection. The failure profiles of the concrete-infill-only shear connection are depicted in Fig. 21. The top section of the concrete infill element was crushed by the web in the direction of the longitudinal shear force. The rest part of the concrete infill element was ruptured by the tensile splitting in the transverse direction. The fibre reinforcements were pulled in the transverse direction, as depicted in Fig. 21, which further demonstrated the tensile failure mechanism of the concrete infill element.

The failure profiles of the tie-bar (Ø12mm) shear connection, depicted in Fig. 22. The top tie-bar was sheared off as it was positioned close to the perimeter of the web opening and in direct contact with the slips of the steel section. The other tie-bar remained intact from the shear force; it was in the mechanism of providing the tensile force (or tie force) to the concrete slabs. The concrete infill element of the tie-bar shear connection demonstrated the same failure profiles as that shown in the concrete-infill-only shear connection. The top section of the concrete infill was crushed in the direction of the longitudinal shear force. The

rest part of the concrete infill was ruptured by the tensile splitting force in the transverse direction. This further indicated that the failure mechanisms of the concrete infill element were the combination of crushing and tensile splitting.

The test specimens of tie-bar ($\text{Ø}16\text{mm}$) shear connection could not be dissembled after the push-out tests, as the $\text{Ø}16\text{mm}$ tie-bars did not fail and tied the concrete slabs firmly together. The load-slip curves, depicted in Fig. 17, showed the ductile failure mode of the shear connection with the characteristic of maintaining the ultimate loads with large slips. This demonstrated that the tensile strength of the tie-bar became effective and contributed to the shear resisting mechanisms of the tie-bar shear connection. The large slips indicated the significant crushing of the concrete infill element by the web. The separations or splitting were also shown at the ultimate load levels. Hence, the failure mechanisms of the concrete infill element in the tie-bar ($\text{Ø}16\text{mm}$) shear connection were the combination of crushing and tensile splitting.

The failure profiles of the ducting shear connection are shown in Fig. 23. The concrete infill element between the web opening and ducting was first crushed by the web opening. This had led to the deformations of the ducting in the direction of the longitudinal shear force. Because of the thickness and geometry of the ducting, the spiral locking of the ducting was eventually ruptured when the steel section further slipped in the longitudinal shear direction. The separation or splitting values were less than 0.5mm, indicated the tensile failure of the concrete infill element in the transverse direction.

The failure profiles of the web-welded stud shear connection, depicted in Fig. 24, showed that the headed studs sheared off with bending near the roots. The concrete around the studs was crushed in the shear direction. The shear failure mechanism of the headed studs was the one of the major failure mechanisms shown in the standard push-out tests of the studs [8]. The failure mechanisms of the concrete infill element were the same as that of the

concrete-infill-only shear connection, as the top section of the concrete infill was crushed in the shear direction and the rest part of the concrete infill was tensile ruptured in the transverse direction.

The web-welded stud shear connection showed no splitting of the concrete slab in the push-out tests. The studs welded on the web post were lying studs which could cause splitting of slab in the direction of the slab thickness. Annex C of Eurocode 4 (EN1994-2:2005) [9] provided specifications for design of lying studs. Although the web-welded stud shear connection showed no splitting of the concrete slab in the push-out tests, it is recommended that the design of the web-welded stud shear connection in practice should conform to Annex C of Eurocode 4 (EN1994-2:2005).

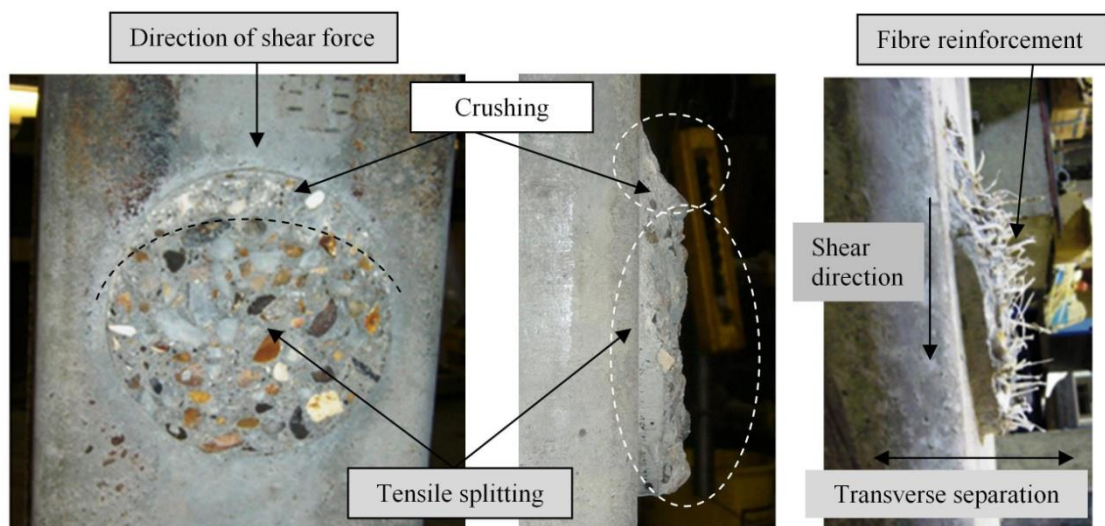

Fig. 21. Failure profiles of the concrete-infill-only shear connection

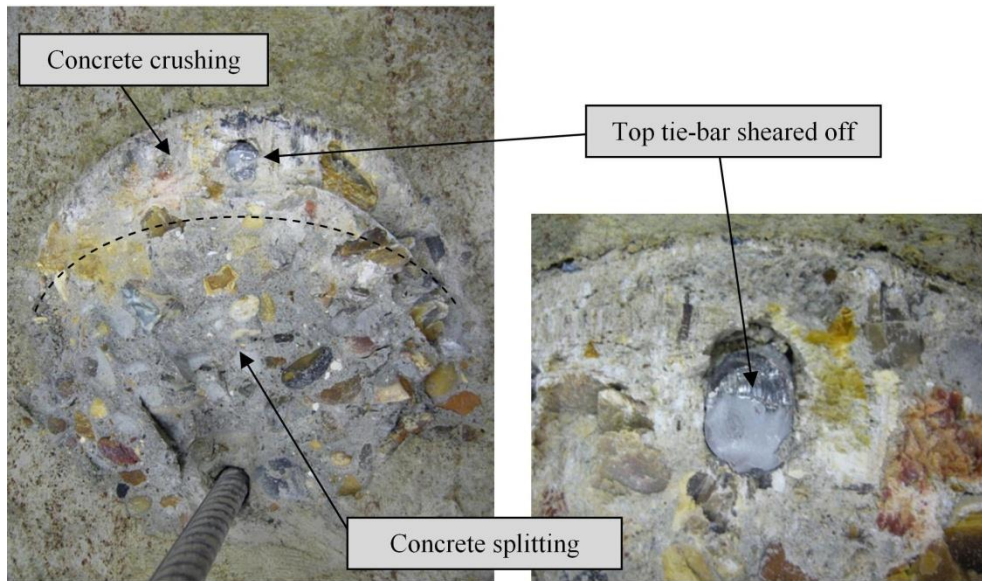

Fig. 22. Failure profiles of the tie-bar ($\text{Ø}12\text{mm}$) shear connection

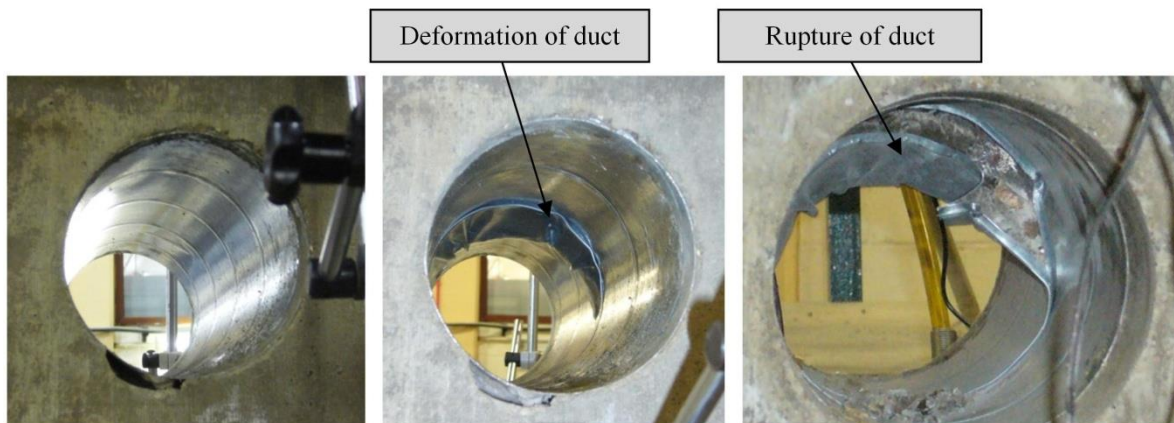

Fig. 23. Failure profiles of the ducting shear connection

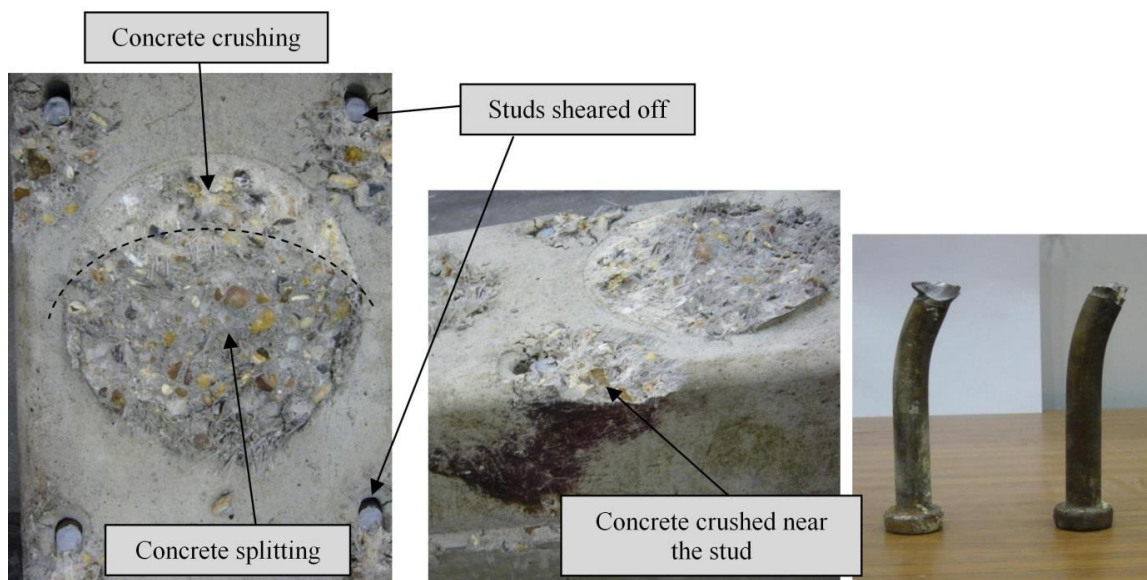

Fig. 24. Failure profiles of the web-welded stud shear connection

5. Analytical study

The analytical study was carried out on the results of push-out tests with the aim of establishing a calculation method for the shear resistance of the shear connection used in the composite shallow cellular floor beams. The four types of shear connection investigated were formed by the web opening with or without other additional elements, i.e. tie-bar, ducting or headed studs. The push-out tests clearly showed gained shear resistance from the additional elements of tie-bar and headed studs. There was no isolated failure between the concrete infill element and additional elements. Therefore, the shear resistance of the shear connection should be the combination of resistance of both concrete infills and additional elements.

The development of calculation method for the shear resistance of the shear connection was based on the failure mechanisms shown in the push-out tests. The failure mechanisms of the concrete infill element of all shear connection was the same. The top section of the concrete infill was crushed by the web in the shear direction and the rest part of the concrete infill was ruptured by tensile splitting in the transverse direction. The shear resistance of the concrete infill element could be calculated by taking account of both compressive and tensile (splitting) resistance, as expressed in Eq. (1). The shear resistance of the shear connection with additional element, i.e. tie-bar or headed studs, was calculated as the combined resistance of the concrete infill element and additional elements, as expressed in Eq. (2).

$$R_{ce} = a(f_{cu}A_c) + b(f_{ct}A_t) \quad (1)$$

$$P_c = a(f_{cu}A_c) + b(f_{ct}A_t) + R_{add} \quad (2)$$

$$(A_c = tD \text{ and } A_t = \pi D^2/4)$$

Where R_{ce} is the shear resistance of the concrete infill element, P_c is the shear resistance of the shear connection, f_{cu} is the concrete compressive cube strength in N/mm^2 , A_c is the area of concrete infill in the compression, f_{ct} is the concrete tensile splitting strength in N/mm^2 , A_t is the area of concrete infill in the tensile splitting, a and b are the coefficients, R_{add} is the

shear resistance of the additional elements (i.e. tie-bar or headed studs), t is the thickness of the web, and D is the diameter of the web opening.

By substituting the test results into Eq. (2), a total of 204 sets of simultaneous equations were formed between any two test specimens. The sets of coefficients, a and b , were obtained by solving the simultaneous equations. The empirical values of a and b were calculated by taking average, as $a = 1.68$ and $b = 1.44$. Hence, Eq. (2) became as:

$$P_c = 1.68(f_{cu} A_c) + 1.44(f_{ct} A_t) + R_{add} \quad (3)$$

There were in total of 24 test specimens, but results of 21 test specimens were used in the analysis. The results of two test specimens, T1-A-N and T1-A-F, were omitted from the analysis. The test set up for the two specimens was different from all other test specimens, as no plaster (gypsum) was applied on the test rig platform; hence, eccentric loading might have caused the specimens failed at lower load levels. Test specimen of T4-B-A was also omitted from the analysis, as the test specimen did not fail due to the capacity of the hydraulic jack was reached.

The ductile slip behaviour and failure mode of the tie-bar shear connection clearly showed that the tensile resistance of the tie-bar became effective and contributed to the overall shear resistance of the shear connection. The tensile resistance of the tie-bar as the additional resistance, R_{add} , was calculated using the material strength obtained from coupon tests, as

$$R_{tb} = f_y \left(\frac{\pi D_{tb}^2}{4} \right) \quad (4)$$

Where R_{tb} is the tensile resistance of the tie-bar, f_y is the yield strength of the tie-bar, and D_{tb} is the diameter of the tie-bar. The yield strength obtained from the coupon tests for the $\text{Ø}12\text{mm}$ and $\text{Ø}16\text{mm}$ tie-bars was 440N/mm^2 and 442N/mm^2 respectively.

The headed studs of the web-welded stud shear connection showed the shear failure, which was one of the dominant failure mechanisms in the standard push-out tests for the studs [8]. The shear resistance of the studs as the additional resistance, R_{add} , was calculated as:

$$P_{Rd} = \frac{0.8 f_u \pi d^2 / 4}{\gamma_v} \quad (5)$$

Where P_{Rd} is the design shear resistance of the stud, f_u is the yield strength of the stud, d is the diameter of the shank of the stud, and γ_v is the partial factor. The Eq. (5) was the formula given in Eurocode 4 (EN1994-1-1:2004) for the design shear resistance of the headed studs. The partial factor, γ_v , was omitted in the calculation of the shear resistance. The strength of material, $f_u = 452 \text{N/mm}^2$ used in the calculation was the yield strength of the studs obtained in the coupon tests. The shear resistance of each web-welded stud shear connection in the test specimens were the combination of resistance of one concrete infill element with 2.67 studs, as there were three concrete infills combined with eight studs to form three web-welded stud shear connection in each test specimen.

5.1. Back comparison

The results of the push-out tests were compared with the calculated shear resistance of the shear connection using the Eq. (3). The actual concrete strengths of the shear connection were used in the calculation. The comparison is shown in Table 4. The calculated shear resistance was very close to the results of the push-out tests. This demonstrated that the empirical coefficients of Eq. (3) were valid.

The back comparisons for specimens of T2-B-N and T4-B-F were optimistic by around 25%. Specimens of test groups of T1 – T4 having different variables, had back comparisons that fluctuated round a ratio of 1.0. The back comparisons for the test groups of T5 and T6, which had four identical specimens, were consistently below unity.

Table 4 Comparison of test results and calculated shear resistance

Specimen No.	f_{cu}	f_{ct}	A_c	A_t	R_{add} (kN)	P_c^a (kN)	Test results (kN)	Ratio (cal/test) ^b
T1-A-N	56.5	4.53	1290	17671	--	237	118	2.009 ^b
T1-A-F	58.1	4.85	1290	17671	--	249	131	1.898 ^b
T1-B-N	56.5	4.53	1980	31416	--	392	362	1.082
T1-B-F	58.1	4.85	1980	31416	--	412	397	1.037
T2-A-N	54.5	4.54	1290	17671	100	333	309	1.078
T2-A-F	51.9	4.07	1290	17671	100	315	305	1.034
T2-B-N	54.5	4.54	1980	31416	100	486	390	1.245
T2-B-F	51.9	4.07	1980	31416	100	456	372	1.225
T3-A-N	55.2	3.91	215 ^c	5400	--	50	47	1.068
T3-A-F	51.5	3.89	215 ^c	5400	--	49	50	0.974
T3-B-N	55.2	3.91	495 ^c	13744	--	123	125	0.983
T3-B-F	51.5	3.89	495 ^c	13744	--	119	137	0.872
T4-A-N	67.0	4.66	1290	17671	272	535	504	1.062
T4-A-F	50.2	4.08	1290	17671	272	484	427	1.134
T4-B-N	67.0	4.66	1980	31416	272	--	--	--
T4-B-F	50.2	4.08	1980	31416	272	623	497	1.253
T5-1	35.0	3.21	1290	17671	--	157	227	0.693
T5-2	35.0	3.21	1290	17671	--	157	194	0.808
T5-3	32.0	2.9	1290	17671	--	143	179	0.798
T5-4	30.0	3.02	1290	17671	--	141	164	0.865
T6-1	29.0	2.85	1290	17671	90	225	391	0.575
T6-2	32.0	2.92	1290	17671	90	233	386	0.604
T6-3	28.0	2.49	1290	17671	90	214	327	0.654
T6-4	27.0	2.57	1290	17671	90	214	358	0.597

^a Calculated shear resistance using Eq. (3) with coefficients of $a = 1.68$ and $b = 1.44$.

^b Results of specimens, T1-A-N and T1-A-F, were omitted due to defect set up of the test

^c Compressive area, A_c , calculated by using $t(D-D_d)$ where t is the web thickness, D is the diameter of web opening, and D_d is the diameter of ducting.

6. Conclusions

The shear transferring mechanisms of the composite shallow cellular floor beams are different with the headed shear studs, and have not been studied previously. This paper presented experimental and analytical investigations of the shear transferring mechanisms, which were formed by the web opening with or without other additional elements, i.e. tie-bar, ducting or headed studs. In total, 24 full-scale push-out tests were carried out to study the shear connection in terms of the shear resistance and behaviour. The results of the push-out

tests also provided better understanding for the failure mechanisms of the shear connection.

The analytical study of the test results developed a calculation method for the shear resistance of the shear connection.

The conclusions made from this research are summarised as:

- The push-out tests showed that the shear resistance of the shear connection increased with increase of the web opening diameter and concrete strength.
- The additional elements, i.e. tie-bar or headed studs, significantly increased the shear resistance, slip capacity and ductility of the shear connection.
- The concrete-infill-only shear connection demonstrated the brittle failure mode under the direct longitudinal shear force, with slip capacity of 4 – 5mm. The brittle failure mode was due to the shear connection was formed of concrete infill without any other elements, and concrete was a brittle material.
- The ducting shear connection demonstrated the similar brittle failure mode as the concrete-infill-only shear connection, with slip capacity of 1.5 – 3.5mm. The ducting itself deformed extensively in the shear direction.
- The tie-bar and web-welded stud shear connection demonstrated the ductile failure mode under the direct longitudinal shear force, with slip capacity of 12 – 16mm. Large slips occurred before and after the ultimate loads.
- The shear bond failure shown by the concrete-infill-only shear connection in the test group T1 had no influence on the overall shear resistance and slip behaviour of the shear connection.
- The local shear failure of the $\varnothing 12$ mm tie-bar in the tie-bar shear connection was due to the tie-bar was positioned close to the perimeter of the web opening, and the tie-bar was in direct contact with the web.

- The loading cycles of 25 times between 5 – 40% of the expected failure load showed no effects on the overall slip behaviour of the shear connection, only small slip increase of 0.18mm was monitored during the loading cycles.
- The concrete infill for the Ø150mm web opening combined with an additional Ø16mm tie-bar had increased the shear resistance of the shear connection by twofold, based on the concrete strength of 30N/mm².
- All types of the shear connection investigated in this study demonstrated the strong tie resistance, as very little separation (or splitting) in the transverse direction was shown.
- The failure mechanisms of the concrete infill element in all types of the shear connection were the same as the crushing by web in the longitudinal shear direction combined with tensile splitting in the transverse direction.
- The push-out tests were designed to apply direct longitudinal shear force to the shear connection. The behaviour of the shear connection in these tests would therefore differ from that in composite beams subjected to flexural bending. The shear resistance of the shear connection is likely to be influenced by the position of the plastic neutral axis of the composite section. Hence, the push-out test results for the shear resistance of the shear connection would be upper bound values.

Acknowledgements

The authors would like to express their gratitude to the Engineering Structures Research Centre of the City University London where the tests were conducted. Gratitude was also extended to the ASD Westok Limited for their supply of the steel sections.

Notations

A_c area of the concrete infill element in compression

A_t area of the concrete infill element in tensile splitting

d	diameter of the shank of the stud
D	diameter of the web opening
D_{tb}	diameter of the tie-bar
f_{ct}	concrete tensile splitting strength in N/mm^2
f_{cu}	concrete compressive cube strength in N/mm^2
f_u	yield strength of the stud
f_y	yield strength of the tie-bar
K	stiffness of the shear connection
P_{Rd}	design shear resistance of the headed stud
P_u	ultimate shear resistance of the shear connection in push-out test
P_c	shear resistance of the shear connection
R_{add}	shear resistance of the additional elements, i.e. tie-bar or stud
R_{ce}	shear resistance of the concrete infill element
R_{tb}	tensile resistance of the tie-bar
t	thickness of the web post
γ_v	partial safety factor
δ_u	slip capacity of the shear connection

References

- [1] Hicks S. Current trend in modern floor construction. The Magazine of British Constructional Steelwork Association (BCSA) 2003; 11(1): 32-3.
- [2] Huo BY, Tsavdaridis KD, D’Mello C. Experimental and analytical study of push-out shear tests in ultra-shallow floor beams. In: Proceedings of the 34th international symposium on bridge and structural engineering. 2010. IABSE.

- [3] EUROCODE 4. In: Design of composite steel and concrete structures, Part 1-1: General rules and rules for buildings. European Committee for Standardization; 2004.
- [4] Huo BY. Experimental and analytical study of the shear transfer in composite shallow cellular floor beams. PhD thesis, City University London, 2012.
- [5] Lawson RM, Mullett DL, Rackham JW. Design of asymmetric Slimflor beams using deep composite decking. The Steel Construction Institute, SCI Publication P175, 1997, ISBN: 1859420443.
- [6] Lawson RM, Bode H, Brekelmans JWPM, Wright PJ, Mullett DL. 'Slimflor' and 'Slimdek' construction: European developments. Journal of Structural Engineer 1999; 77(8): 22-30. ISSN: 00392553.
- [7] Hawkins NM. Strength of stud shear connectors. In: Institute of engineering, Australia, Civil engineering transactions. 1973. p. 46-52.
- [8] Easterling WS, Gibbings DR, Murray TM. Strength of shear studs in steel deck on composite beams and joists. AISC Engineering Journal 1993; 30(2): 44-55.
- [9] EUROCODE 4. In: Design of composite steel and concrete structures, Part 2: General rules and rules for bridges. European Committee for Standardization; 2005.