



City Research Online

City, University of London Institutional Repository

Citation: Goodey, R.J., McNamara, A. M. and Panchal, J. P. (2016). Bearing Capacity of Sheet Piled Foundations. Paper presented at the 2nd Asian Conference on Physical Modelling in Geotechnics, 30 Nov-02 Dec 2016, Shanghai, China.

This is the accepted version of the paper.

This version of the publication may differ from the final published version.

Permanent repository link: <https://openaccess.city.ac.uk/id/eprint/17339/>

Link to published version:

Copyright: City Research Online aims to make research outputs of City, University of London available to a wider audience. Copyright and Moral Rights remain with the author(s) and/or copyright holders. URLs from City Research Online may be freely distributed and linked to.

Reuse: Copies of full items can be used for personal research or study, educational, or not-for-profit purposes without prior permission or charge. Provided that the authors, title and full bibliographic details are credited, a hyperlink and/or URL is given for the original metadata page and the content is not changed in any way.

Bearing capacity of sheet piled foundations

J.P., Panchal, A.M., McNamara and R.J., Goodey

Research Centre for Multi-scale Geotechnical Engineering, City University London, UK emails:

Jignasha.Panchal.1@city.ac.uk; A.McNamara@city.ac.uk; R.Goodey@city.ac.uk

Abstract: Bored concrete piles have been used widely on commercial developments in London for about the last 50 years. The life of a commercial building is between 25 – 30 years and, as each building is demolished and rebuilt, the piles from the previous buildings remain in the ground causing obstructions to the new foundations. This paper describes a preliminary study to explore the viability of sheet piled foundations as a genuine alternative to cast in situ concrete piles and all of the complications inherent in their construction and the obstruction they create to subsequent foundations. If it is possible to use steel piles as foundations they can be easily removed, recycled and will not cause obstructions for future developments. However, individual sheet piles have relatively low capacity when axially loaded and it is therefore necessary to consider a sheet pile group in conjunction with a pilecap, which can be considered a hybrid foundation; a combination of shallow (pilecap) and deep (sheet pile). A short series of centrifuge tests is reported in which model sheet pile groups in over-consolidated clay were loaded axially whilst vertical displacements were measured. Equivalent cast in place piles were similarly tested alongside the sheet pile groups by way of comparison.

Keywords: Sheet piles, pile capacity, axial loading

1. Background

Solid circular concrete piles have been extensively used in construction projects worldwide, however once a structure is demolished, the existing piles cause obstructions and delays for any future projects.

The consideration of the removal of existing piles at the end of the design life is often neglected during the design stage. The Federation of Piling Specialists (FPS, 2008) state that concrete piles were traditionally removed using hand-held pneumatic breakers. These caused significant health problems for operatives, particularly hand arm vibration syndrome (HAVS), dust inhalation and excessive noise exposure. Although new technology has been developed to mitigate occupational health risks, the existing concrete piles are still obstructions that need to be removed before construction can commence. In addition to this, it is not possible to break deep obstructions by hand, specialist equipment, such as grinders are required.

An alternative piling construction sequence adopted by Bauer (Symes, 2012) at Moorgate, London was to cut the soil-pile interface, before lifting out and trimming the pile in stages and backfilling the open bore. Although this method

was successful, there was a large volume of crushed concrete waste produced and the technique was time consuming.

2. Introduction

Although, for environmental reasons, it is recommended that existing concrete piles are reused where possible (CIRIA, 2007) it can be difficult to assess their condition as they may have deteriorated over time making it difficult to predict their capacity or integrity.

New piles can be bored adjacent to the existing piles to achieve the required capacity; however if there are obstructions on site the pile spacing may be insufficient and may result in excessive settlement.

On the other hand, if existing piles could easily be removed and recycled, it would make the design and construction of infrastructure more economic and less time consuming as new pile installation would be carried out in, effectively, virgin ground. Investigating the feasibility of using steel sheet pile groups as load bearing piles is therefore potentially attractive. Hydraulic presses are often used to push individual sheet piles into the ground and can also be used to remove them. Piles that have been left in situ for a prolonged period of time, and are subsequently sealed in the soil, can be

hammered to break the interlock (Filip, 2012) before being extracted using a hydraulic press.

Single sheet piles have relatively low axial load capacity, therefore this research was carried out to investigate the capacity of a sheet pile group with a pilecap.

2. Objectives

The aim of this study was to conduct a series of centrifuge tests at 50g to compare the behaviour of axially loaded sheet pile groups and bored concrete piles.

Results from each test were compared to firstly determine whether a sheet pile group was capable of withstanding axial loads without buckling and also to assess how ultimate load capacity related to a conventional bored concrete pile of similar dimensions.

3. Soil Model

The tests were conducted in a cylindrical centrifuge tub, 420mm in diameter and 415mm deep.

Speswhite kaolin clay was mixed to a water content of 120%, approximately twice the liquid limit and producing a workable slurry. The slurry was carefully placed in the tub avoiding air entrapment before being moved to a hydraulic press for one dimensional consolidation. The sample was consolidated to 500kPa before being swelled to 250kPa thereby creating a relatively stiff overconsolidated soil sample that permitted simple model making.

4. Apparatus

The apparatus used in this experiment was designed by Gorasia (2013) and is illustrated in Figure 1.

This equipment consisted of a simple lead screw actuator supported by a frame that was secured to top of the centrifuge tub. A loading beam attached to the underside of the actuator was used to support load cells and LVDTs.

A model sheet pile foundation was manufactured for testing in the centrifuge. This comprised a profiled sheet pile fabricated by pressing a 0.5mm thick sheet of stainless steel to create the corrugated profile illustrated in Figure 2(a). The sheet pile had 5mm holes drilled at 30mm centres along the length of the

shaft and was then rolled into a cylinder and secured with resin. The sheet pile group was 180mm in length with a maximum diameter of 60mm.

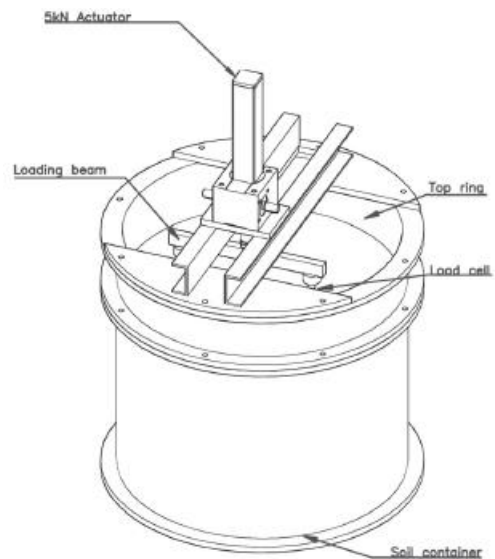

Figure 1. Apparatus set up (Gorasia, 2013)

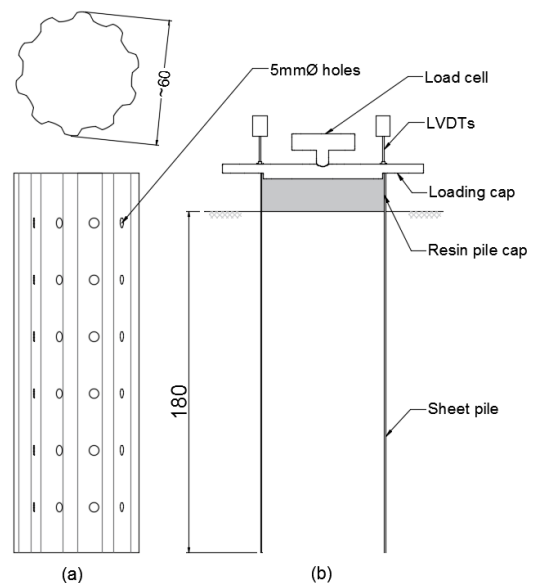

Figure 2. (a) Sheet pile profile in plan and elevation
(b) cross section through sheet pile in clay

Similarly, two solid circular concrete piles were also manufactured for testing. The first simulated a smooth pile (Test A), fabricated using 60mmOD (outer diameter) stainless steel tubing. A base was attached to the bottom of the tube to produce a closed ended cylinder.

A rough concrete pile used in Test B was fabricated from 48mmOD stainless steel tubing. The shaft was coated in a 6mm thick layer of two-part Sika resin thereby creating a pile of identical diameter to that used in Test A. A uniform thickness of resin was achieved by use of two 60mm long plastic inserts drilled and fixed perpendicular to the direction of the pile. These acted as spacers, ensuring the stainless steel tube was evenly coated with resin. Additionally, a 10mm thick Perspex spacer was placed at the bottom of the tube to simulate a rough base concrete pile, illustrated in Figure 3.

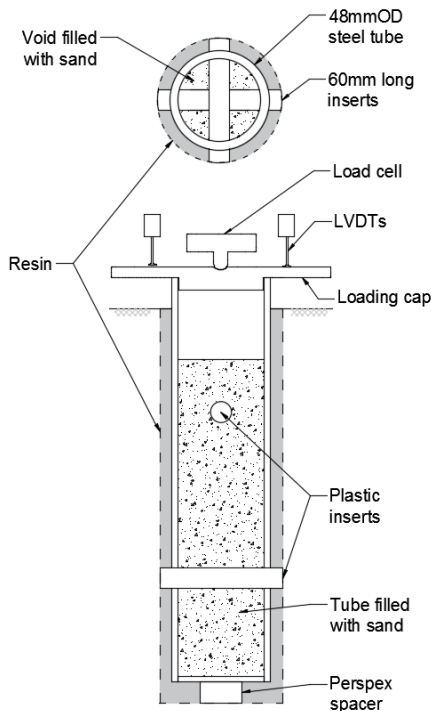

Figure 3. Rough pile geometry and set up

Aluminium plates were used as pilecaps, where the underside was machined to fit the inside diameter of each pile. The top of each pile cap was countersunk creating sufficient contact

and alignment for the Omega 5kN miniature load cells. These pile caps were wide enough to support the LVDT footings.

5. Testing Procedure

One pore pressure transducer (PPT) was installed at the same time as the sample was swelled to 250kPa. The PPT was installed horizontally at the centre of the tub and was backfilled with de-aired kaolin slurry with a water content of 120% approximately 24 hours before the soil sample was removed from the consolidation press.

Once the centrifuge tub was removed from the hydraulic consolidation press, the extension was unbolted and lifted off. The clay sample was prepared under 1g conditions and the clay trimmed to the top of the tub using a wire cutter. The top of the sample was sealed using PlastiDip; a synthetic rubber coating proven to prevent clay samples from drying out in flight (Gorasia, 2013).

The apparatus frame was placed on the tub and loading bar lowered so that the load cells indented the clay surface to indicate the pile centres.

A scribe was used to mark out the circumferences of each pile. The sheet pile group was carefully aligned with the marked out circumference and pushed vertically into the clay to a depth of 180mm under 1g conditions.

A thin walled tube cutter guided by a brass collar was used to remove a core of clay to a depth of 180mm to allow the solid pile to be placed. To prevent the pile from becoming buoyant, the excavated clay was weighed and the hollow tube was filled with sand to provide an appropriate surcharge load. This approach ensured the total weight of the sand and tube was equal to the weight of clay removed from the bore.

In the smooth pile test, a 60mmOD tube was inserted into the open bore, before commencing the sheet pile group installation.

The rough pile tests were carried out in a similar manner, whereby a 60mm diameter bore was created and the weight of the clay recorded. Half of the resin was then poured into the open bore before inserting the 48mmOD tube with the preinstalled plastic inserts. The inserts ensured that the tube remained central to the bore while

the resin was displaced along the pile shaft. The remaining resin was poured around the pile to raise the level to the top of the clay. From a preliminary test using the same testing procedure, a pile coated in cured resin weighed 555g. Using this information the correct weight of sand could be poured into the pile to eliminate the risk of buoyancy.

The pile caps were then placed on the piles before securing the actuator frame, load cells and LVDTs to the centrifuge tub. Two LVDTs were placed either of each pile and were used to measure the pile displacement, relative to the lead screw. The use of two LVDTs permitted checks to be made to ensure the piles were not eccentrically loaded. The test set up is illustrated in Figure 4.

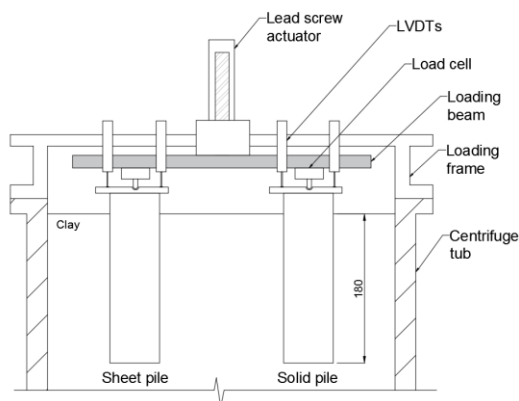

Figure 4. Centrifuge test set up

The package was then placed onto the centrifuge swing and a standpipe connected to the base drain to maintain a water table 30mm below the clay surface.

The model was accelerated to 50g and left to consolidate until the excess pore pressures had dissipated. The sample was then tested by controlling the actuator to lower the loading beam at a rate of 1mm/min. The tests were stopped once the pile had reached its ultimate capacity or after 10% axial strain.

6. Test Results

Two centrifuge tests were carried out and are presented below. In each experiment there were two test sites, where the capacity of a sheet pile was compared with two bored piles of varying

surface roughness, providing data for three scenarios.

In each test a sheet pile group and a solid section pile were loaded. The solid and sheet piles were both embedded 180mm and had an average diameter of 60mmOD, to allow for direct comparison between the two models. At prototype scale, this represents 9m long piles, 3m in diameter. The two tests that were carried out with the different pile casings are summarised in Table 1.

Table 1. Summary of tests

Test reference	Test site 1	Test site 2
A	Smooth solid pile	Sheet pile
B	Rough solid pile	Sheet pile

The load displacement curves are plotted in Figure 5 and, not surprisingly, show that a rough pile has a significantly greater load bearing capacity than a smooth pile. The ultimate axial loads for each pile are summarised in Table 2. Comparing the data from the three piles, it can be seen that all piles exhibit similar settlements up to 800N.

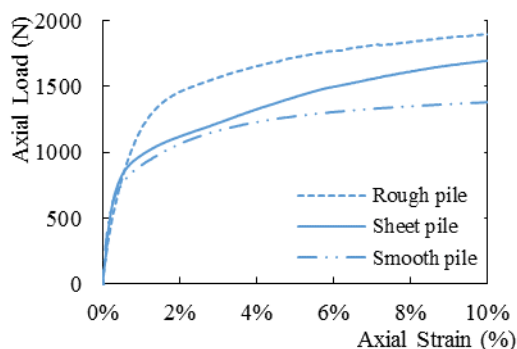

Figure 5. Axial capacity for each pile type

The smooth pile and sheet pile behave similarly up to 3% strain. The smooth pile capacity plateaus as the pile reaches an ultimate capacity of 1.4kN whilst the load applied to the sheet pile continues to rise up to approximately 1.7kN at 10% strain.

The rough pile continues to respond linearly to the applied load up to 2% strain before levelling off and reaching an ultimate load of approximately 1.9kN.

Based on these measurements, a sheet pile with 5mm holes drilled along its shaft has about 25% greater capacity than a smooth pile or has 90% of the capacity of a rough pile.

Table 2. Summary of ultimate axial loads

Pile	Ultimate axial load (kN)
Smooth solid	1.38
Rough solid	1.90
Sheet pile group	1.69

7. Analysis

The two components that contribute to the load resistance (Q_f) of a pile in an undrained loading event include shaft resistance (Q_s) and end bearing (Q_b). In clays, these can be calculated using equations (2) and (3) respectively.

$$Q_f = Q_s + Q_b \quad (1)$$

$$Q_s = EA \alpha S_u \quad (2)$$

$$Q_b = EA (N_c S_u + \gamma L) \quad (3)$$

Where EA is the area of the pile in contact with the clay, S_u is the average undrained shear strength of the soil which was 48kPa in each test (based on hand shear vane readings taken immediately after the test), the bearing capacity factor (N_c) is 9 for deep piles, γ is the bulk unit weight of the soil taken as 17kN/m³, L is the pile length and α is the adhesion factor.

A comparison was made between the measured axial capacities of the piles and values calculated using the total stress analysis. The end bearing resistance of the solid piles were calculated and then subtracted from the ultimate capacity to determine the shaft resistance. Values of α were then calculated and compared with field data to establish whether the results from these experiments were reliable. The results are given in Table 3 and give values of α that are reasonable for these particular values of pile roughness in stiff clays.

Table 3. Calculated values of α for solid piles

Pile	Q_b (kN)	Q_s (kN)	α
Smooth solid	1.23	0.15	0.093
Rough solid	1.23	0.69	0.411

For the sheet pile analysis, the hybrid pile was considered as two elements; the sheet pile which contributed to the shaft resistance and the pile cap which displaced the soil beneath it as

the pile settled. For this reason, it was assumed that the undrained shear strength of the clay in contact with the inner face of the pile was not mobilised. Thus skin friction was considered to be acting only on the outer sheet pile face. Assuming a value of 0.3 for α for the pile group to clay interface, N_c as 6.25 and S_u as 40kPa at the surface.

Using these values, the end bearing and shaft resistance were computed as 0.71kN and 0.52kN respectively. This resulted in an ultimate capacity of 1.23kN, which was 27% lower than the actual load measured in the centrifuge tests.

7. Discussion

Piles in clay obtain their capacity from the interaction of the soil along the shaft. Since the shaft resistance can be calculated using equation (2), it is reasonable to assume that the sheet pile groups have a greater capacity than a smooth solid pile as the contact area in clay is 7% greater than that of a solid pile.

Unsurprisingly, a rough solid pile has greater capacity than a smooth solid pile, which again is due to the greater skin friction offered by the rough pile surface. It is possible to increase the axial capacity of the sheet pile group by increasing the roughness of the steel sheets. However, it is important to consider the additional resistance that would be encountered when installing the sheets.

The discrepancy between the computed and measured capacity of the sheet pile could be due to the additional resistance offered by drilling holes in the pile shaft. Back analysing the sheet pile in a similar manner to the solid piles to determine the value of α for the skin friction found that α was equal to 0.565.

9. Conclusions

Two centrifuge tests at 50g were conducted to investigate the feasibility of using sheet pile groups as load bearing piles over traditional solid concrete piles. The tests involved simultaneously loading a solid pile and a sheet pile group whilst measuring the load and settlements. The sheet pile group consisted of an embedded sheet pile in a circular orientation and a resin pile cap. In the two tests both a smooth solid pile and a rough solid pile were tested against a sheet pile which had 5mm holes drilled

along its shaft. The pile geometries were comparable and the experiment set up, soil type and testing procedure were identical in both tests.

The results were consistent and showed that a sheet pile group reaches up to 90% of the capacity of a rough solid pile. Also, whilst the surface of the sheet pile was similar to that of a smooth solid pile, the capacity of the sheet pile group was 27% greater than the smooth solid pile.

10. Further work

Although a circular orientation is the most efficient sheet pile group arrangement, a small diameter may not be achievable on site. Therefore it is proposed that alternative geometries are investigated to determine their efficiency, such as rectangular groups.

Additionally, the piles that were represented in this experiment are not considered slender. Further tests with longer piles should be used for more realistic data that is representative of current construction practices.

Further tests with different sized holes in the sheet pile could be carried out to establish the relationship between drilled holes and increased sheet pile group capacity.

11. Acknowledgement

The authors would like to acknowledge the assistance of Jason Kairouz in performing the experiments as part of his undergraduate dissertation at City University London.

12. References

- CIRIA (2007) C653: Reuse of Foundations. CIRIA, London.
- Federation of Piling Specialists. (2008) Breaking down of piles. Piling Specification Guidance. www.fps.org.uk.
- Filip, R. (2012) Chapter 11; Sheet piling. Temporary Works; Principles of Design and Construction, Grant & Pallett (eds.). ICE Publishing, London, UK, pp. 129–144.
- Gorasia, R.J. (2013) Behaviour of ribbed piles in clay. PhD thesis, Research Centre in Multi-scale Geotech. Eng., City University London, UK.

Symes, C. (2012) Removing obstructions to redevelopment. European Foundations, Magazine of the European Federation of Foundation Contractors, UK.