



City Research Online

City St George's, University of London

Citation: Olabi, A. G., Mahmoud, M., Soudan, B., Wilberforce, T. & Ramadan, M. (2020). Geothermal based hybrid energy systems, toward eco-friendly energy approaches. *Renewable Energy*, 147, pp. 2003-2012. doi: 10.1016/j.renene.2019.09.140

This is the accepted version of the paper.

This version of the publication may differ from the final published version. To cite this item please consult the publisher's version.

Permanent repository link: <https://openaccess.city.ac.uk/id/eprint/23694/>

Link to published version: <https://doi.org/10.1016/j.renene.2019.09.140>

Copyright and Reuse: Copyright and Moral Rights remain with the author(s) and/or copyright holders. Copies of full items can be used for personal research or study, educational, or not-for-profit purposes without prior permission or charge, unless otherwise indicated, provided that the authors, title and full bibliographic details are credited, a hyperlink and/or URL is given for the original metadata page and the content is not changed in any way. For full details of reuse please refer to [City Research Online policy](#).

1 **Geothermal based hybrid energy systems, toward eco-friendly energy**

2 **approaches**

3 Abdul-Ghani Olabi^{1,2}, Montaser Mahmoud^{3,4}, Bassel Soudan⁵, Tabbi Wilberforce⁶ and Mohamad
4 Ramadan^{7,8*}

5 ¹Sustainable and Renewable Energy Engineering, University of Sharjah, Sharjah, UAE.

6 ²Mechanical Engineering and Design, Aston University, School of Engineering and Applied
7 Science, Aston Triangle, Birmingham, B4 7ET, UK.

8 ³Lebanese International University, PO Box 146404 Beirut, Lebanon.

9 ⁴Mechanical Engineering, City, University of London, UK.

10 ⁵Electrical and Computer Engineering Department, University of Sharjah, UAE

11 ⁶The University of the West of Scotland, Institute of Engineering and Energy Technology, UK.

12 ⁷International University of Beirut, PO Box 146404 Beirut, Lebanon.

13 ⁸Associate member at FCLAB, CNRS, Univ. Bourgogne Franche-Comte, Belfort cedex, France.

14

15 **Abstract**

16 Geothermal Energy is a very attractive source of naturally-occurring green renewable energy.
17 Exploiting this natural resource is straightforward and causes almost no ill effects to the
18 environment. But, while geothermal does not suffer the intermittence of other renewable sources, its
19 extraction efficiency is fairly modest as compared to other sources. As a result, there has been
20 significant interest recently in hybrid systems that integrate geothermal and other forms of energy to
21 increase the output efficiency. This work will survey the different possible integrations involving
22 geothermal energy. A review of the literature shows that the most common hybrid systems
23 implementation involve the integration of geothermal with solar (45% of systems) followed by the
24 integration of a cooling tower into the geothermal system (30% of systems). This work will also
25 investigate the applications for geothermal hybrids and show that 44% of systems are designed for
26 heating applications. Another 44% are used for cooling while only 12% are designed for electrical
27 power generation. Complexity of control remains as the main obstacle facing hybrid multi-source
28 energy systems including those involving geothermal energy.

29 **Keywords:** Geothermal energy, Hybrid System, Environment, Heating, Cooling, Power generation

30 **1. Introduction**

31 As the population of our planet increases, so does the need and demand for energy [1]. Until
32 recently, this demand has been met mostly through the consumption of traditional mainly fossil-
33 based fuels. The consumption of these carbon based fuels has been shown to be directly linked to
34 global warming, pollution and a deterioration of air quality. This issue is of particular concern due
35 to its widespread effect. The latest report by the World Health Organization (WHO) released in
36 May 2018 states that “*90 percent of people worldwide breathe polluted air*” [2]. Governments
37 around the world are increasingly investing in renewable energy sources (RES) as possible
38 replacements (to some extent) for fossil-based fuels and their ill effects on the environment. RES
39 are able to meet a significant portion of the energy demand without the harmful greenhouse gases
40 and the associated pollution. All forms of RES are being investigated: solar (both photovoltaic and
41 thermal), wind, ocean, marine, hydropower, as well as geothermal and biomass among others. One
42 of the issues affecting most RES is their stochastic intermittent nature. The energy source is not
43 available all the time, and sometimes it is not sufficient even when available.

44 This is where geothermal energy has an advantage over most other RES, its availability is
45 approximately deterministic and independent of ambient conditions. While it may be geographically
46 limited, wherever geothermal energy is present it is useable all the time at approximately the same
47 level. Geothermal energy has the added advantage of actually attaining lower operating cost
48 compared to traditional systems [3, 4].

49 Another advantage of geothermal energy is that the energy reservoir (the ground) can act as
50 a source as well as a sink depending on the need. Compared to air, soil has a much higher heat
51 capacity. As a result, seasonal variations of soil temperature deep in the ground are much lower than
52 those of the surrounding ambient air. At depths higher than about 20 meters, soil temperature
53 becomes approximately constant year-round. This makes deep earth warmer than ambient air in the

54 winter and cooler in the summer. Ground heat exchangers have been designed to leverage this air-
55 to-soil differential to condition the ambient air temperature.

56 There are three different configurations for a ground heat exchange: vertical, horizontal and
57 spiral (see Fig. 1). The type of configuration depends mainly on available space and soil conditions.
58 The horizontal configuration is typically constructed at a depth less than 1.5 meters [5], while the
59 vertical configuration (commonly known as the borehole heat exchanger (BHE)) typically reaches
60 depths more than 50 meters [6]. Under appropriate circumstances, it is possible to create a
61 combination of vertical and horizontal configurations that will produce better thermal performance
62 [7]. The ground heat exchanger is usually surrounded by grout material (such as cement or a
63 mixture of sand and bentonite) to protect ground water and improve heat transfer. Geothermal
64 energy is typically considered in hybrid combinations because it is characterized as a low grade
65 source of energy. Adding a geothermal source serves mainly to decrease the operating cost and
66 environmental effects compared to conventional plants. This paper discusses applicable
67 combinations of geothermal energy with other sources while presenting the differentiating factors
68 between the different hybrid combinations.

69

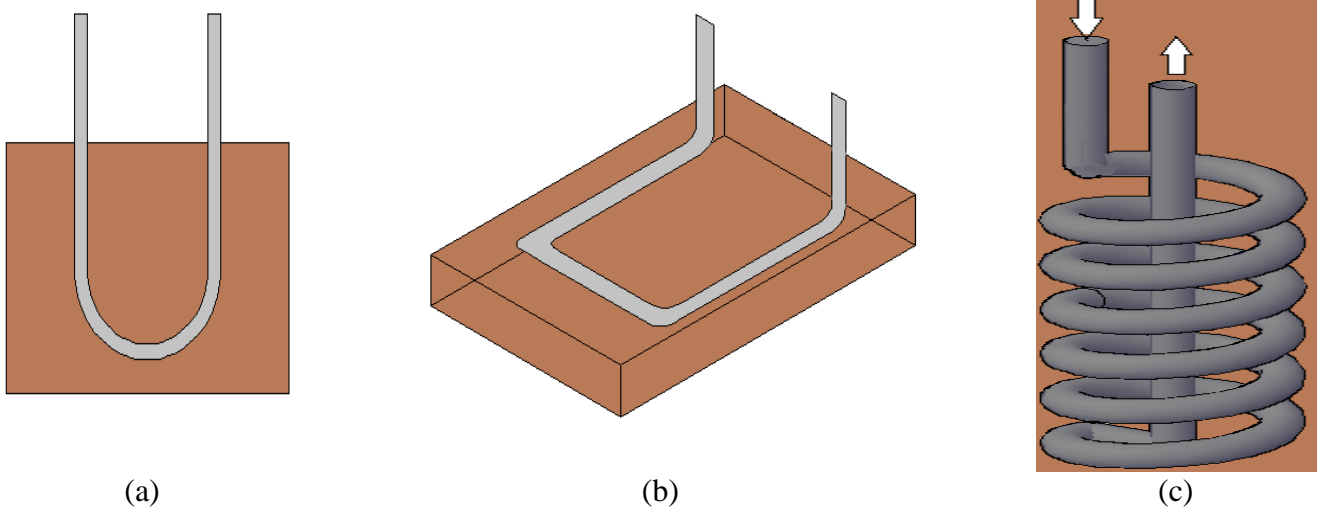

70 **Fig. 1.** GHE configurations; (a) vertical, (b) horizontal and (c) spiral

71 **2. Geothermal Power Plant**

72 Geothermal Energy can be used as a source for power generation plants through the use of
73 an Organic Rankine Cycle (ORC) as an example. Replacing conventional plants with geothermal
74 ones is an attractive proposal for implementing ecofriendly systems [8]. Geothermal plants produce
75 far lower emissions as compared to fossil fuels for the same given load. However, geothermal
76 energy is characterized as a low grade energy source and generally suffers from low energy
77 extraction efficiency. Additional sources of energy can be combined through a hybrid system to
78 improve the efficiency and meet the requirements that geothermal energy alone may not able to
79 deliver [9, 10].

80 Geothermal energy systems used in heating (or cooling) dominated applications suffer an
81 efficiency degradation due to heat depletion (or accumulation) that may lead to eventual system
82 failure or ground fouling [11-13]. Adding a hybrid power source will allow time for recovery and
83 thermal build-up (or dissemination). In addition, hybridization helps in decreasing the required
84 capital and operating costs, and hence shortening the payback period of geothermal energy
85 installations as well as addressing high peak loads [14, 15]. This could be achieved by taking
86 advantage of optimal conditions for each source in the hybrid combination. Geothermal energy
87 systems require a significant upfront initial investment. On the other hand, they require very low
88 operational running costs. A balance can be achieved by incorporating a second abundantly
89 available energy source into the hybrid plant. The expense profiles of the two sources can be
90 balanced against each other to lower the overall costs of the hybrid plant.

91 **3. Hybrid Geothermal Systems (HGS)s**

92 Hybrid Geothermal Systems (HGS) used for heating and cooling applications are commonly
93 encountered in the form of a hybrid ground source heat pump (HGSHP) [16] or a hybrid ground
94 coupled heat pump (HGCHP) [17, 18]. Fig. 2 shows the difference between the conventional and
95 hybrid ground source heat pump (GSHP) designs.

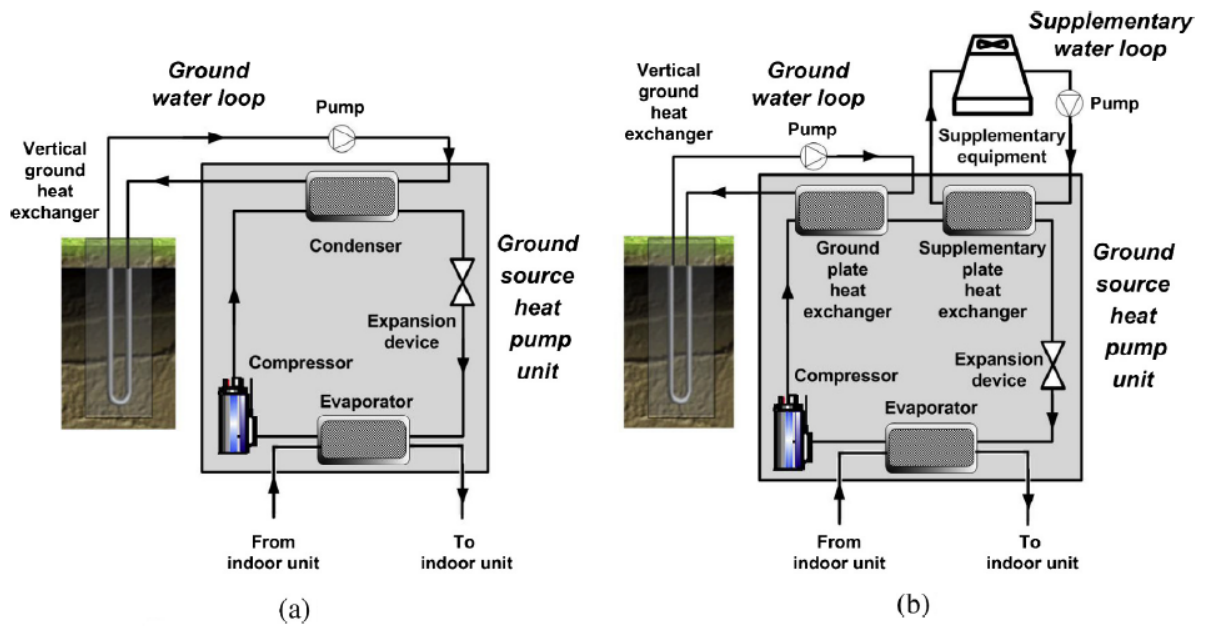

96
97 **Fig. 2.** Difference between (a) GSHP and the (b) HGSHP [19]

98 Another type of ground coupled heat exchanger (GCHE) is the earth air heat exchanger
99 (EAHE) based on circulating fresh air underground using a blower (as shown in Fig. 3 [20].

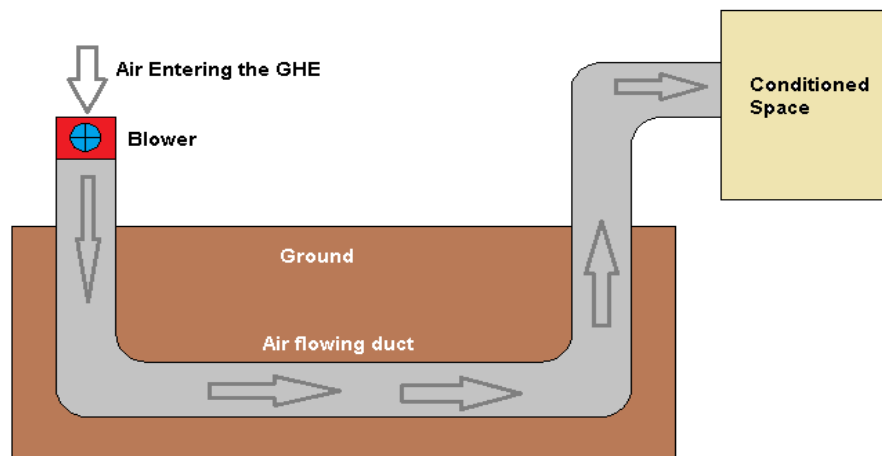

100
101 **Fig. 3.** Earth Air Heat Exchanger System

102 M. Alavy et al. [21] investigated the use of an HGSHP for district heating and cooling
103 through a common water loop distribution. The system showed high potential that depends mainly
104 on building size and type as well as weather conditions and location. One of the most important
105 parameters to be studied in these hybrid systems is the ratio between the heating and cooling loads
106 in order to design the optimum ground regeneration cycle. Regenerating the ground potential can be
107 achieved by adding a second energy source as mentioned above, or through a traditional heating,
108 ventilating and air conditioning (HVAC) system based on an air source heat pump (ASHP). On the

109 other hand, it is possible to achieve the required regeneration using a dry cooler. The cooler can be
110 used to inject ambient heat in to the cold bore field in the winter and extract it from the warm bore
111 field in the summer. This would require the use of a dual bore field [22]. Choosing the best hybrid
112 system is not straightforward because each HGS has to be considered from a different perspective
113 such as initial or operating cost [23].

114 Geothermal energy can be coupled with many different energy sources depending mainly on
115 availability and effect on system's performance. In the following sub-sections, we will discuss a
116 number of possible integrations that involve geothermal energy systems.

117 3.1. Integration of Geothermal and Solar Energy Systems

118 There is a number of ways that solar and geothermal energies can be integrated to form a
119 hybrid energy system [24]. For example, thermal solar collectors can be used to generate additional
120 heat energy to shore-up any deficit from the geothermal system. A common hybrid solar-
121 geothermal combination is the solar assisted ground source heat pump (SAGSHP) [25]. While there
122 may be different implementations, the main objective of this combination is the reduction in annual
123 operating costs and CO₂ emissions. Thermal solar collectors can also be used for ground heat
124 recovery and help stabilize the geothermal system. Conversely, a geothermal heat exchanger can be
125 used as a second heat source to support a solar thermal plant [26-28]. This combination has the
126 ability to increase the overall efficiency by 3.6% compared to the combined individual systems
127 [29]. Another motivation for integrating geothermal and solar thermal systems might be the need to
128 increase the steam flow in the geothermal cycle [30]. Researchers have been able to reduce the
129 initial costs associated with a geothermal system by using a solar assisted ground source heat pump
130 to reduce the required borehole heat exchanger field size. It is also possible to use a supercritical
131 ORC based on a geothermal system integrated with a concentrated solar power system to increase
132 peak loads for demand-side management [31, 32]. While most hybrid systems are designed for

133 heating applications, it is also possible to integrate a ground heat exchanger with a solar cooling
134 system to improve its performance [33].

135 Solar thermal systems suffer from seasonal deterioration in energy output depending on the
136 sun's position and ambient air temperatures. One way to improve the seasonal coefficients of
137 performance is to use the geothermal system as a seasonal energy storage. A vertical ground heat
138 exchanger may be used to store seasonal excess energy generated by a solar thermal system. The
139 system would be composed of solar collectors, short-term thermal storage devices, a heat pump, and
140 a borehole heat exchanger for long-term storage. A staged series of ground heat exchangers can be
141 used to reduce temperature differences and maintain the effectiveness of the storage system for an
142 elongated period [34]. Ground water flow may be the main limiting factor against the use of such an
143 integration [35]. Ground water flow levels at the site must be low enough to ensure that the induced
144 thermal plume is not dissipated. Researchers have determined that seasonal heat storage is not
145 reliable for solving the thermal imbalance if ground water seepage velocity is large.

146 As can be seen from the above examples, integrating a solar thermal system with a
147 geothermal plant can either assist in producing additional power, or reducing the consumed
148 geothermal energy [36]. An essential factor to consider in the design of hybrid solar-geothermal
149 systems is the state of the available ground fluid. If the available fluid is in the steam-liquid state,
150 then a flash cycle (see Fig. 4 and Fig. 5) would be the preferred design [37, 38]. Incorporating the
151 solar system contributes to superheating and evaporating the geothermal fluid and therefore
152 boosting the generated power [29].

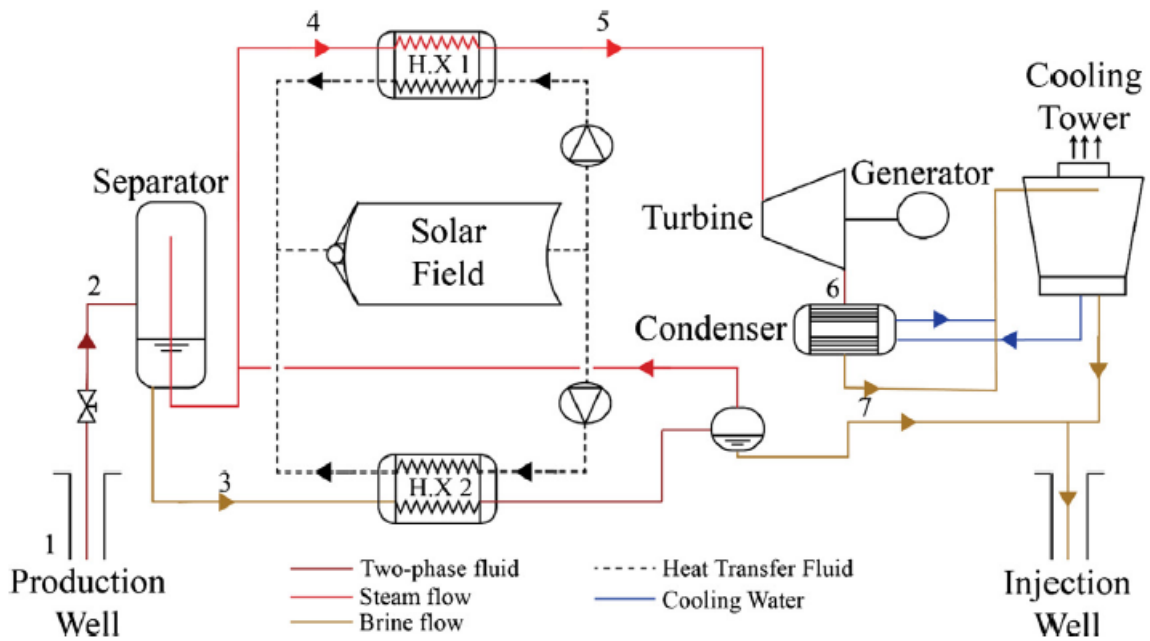

153
154
155
Fig. 4. Single-Flash Hybrid Power Plant [37]

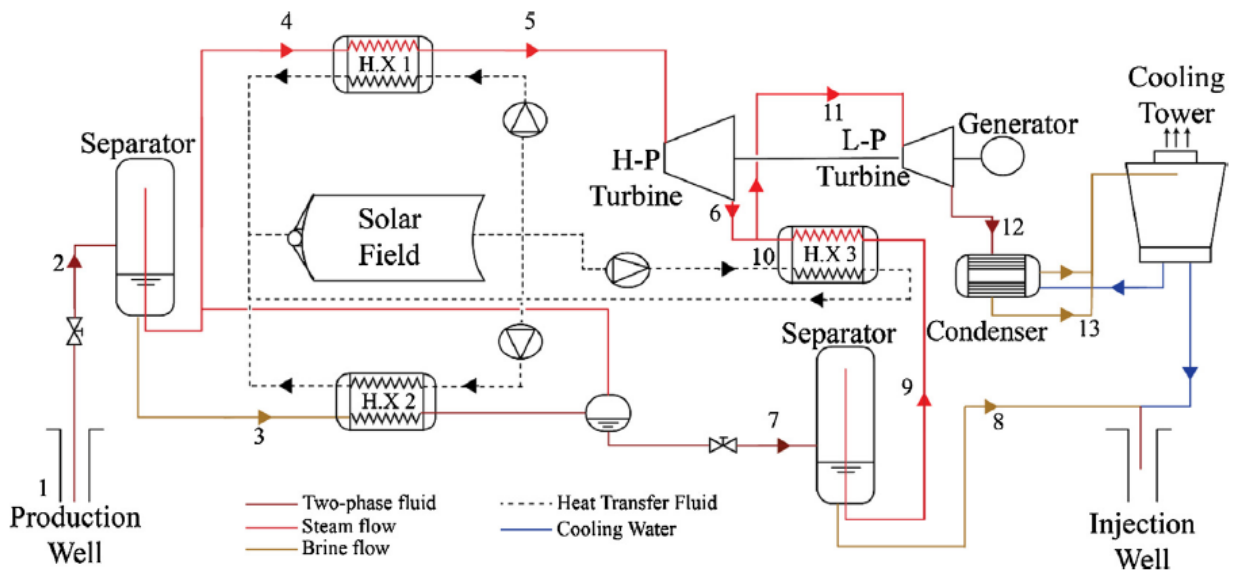

156
157
Fig. 5. Double-Flash Hybrid Power Plant [37]

158 A photovoltaic thermal hybrid system (PVT) can be integrated with a GSHP to produce
159 different forms of energy at the same time (as shown in Fig. 6). While the GSHP system works on
160 extracting thermal energy from the ground, the PVT system produces electrical energy from the
161 incident sun light and at the same time extracts additional thermal energy from the sun's heat.
162 Careful consideration for the working fluid is necessary to ensure best results from these systems.
163 Most designs have concentrated on using organic fluids [39]. However, it is also possible to use a

164 refrigerant fluid like CO₂ in which case the cycle would require some modification such as the
 165 incorporation of a reverse trans-critical cycle [40-42]. Other studies have also investigated the use
 166 of hybrid systems for water distillation in addition to energy generation [43]. Recently, poly-
 167 generation and tri-generation systems are becoming more common. The system presented in [44]
 168 shows a solar-geothermal system being used for generating electricity, cooling and hydrogen
 169 production. The energy and exergy efficiencies were found to be 19.6% and 19.1% respectively.

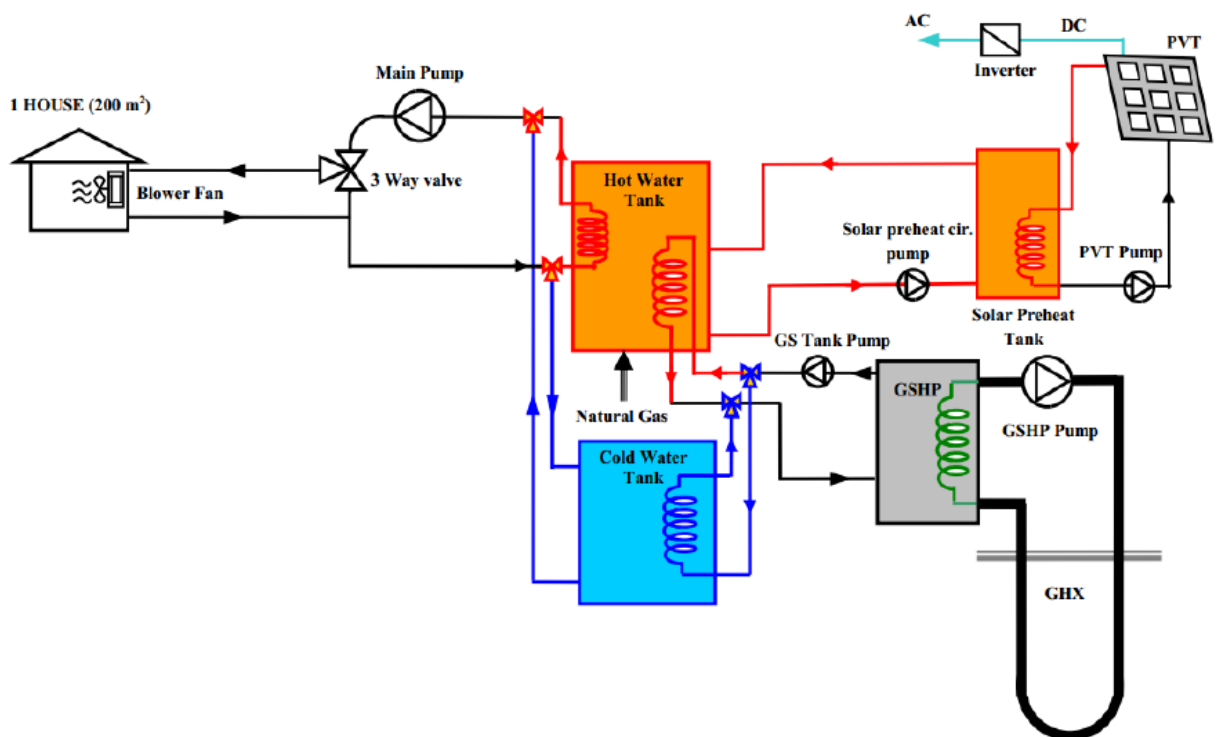

170
 171

Fig. 6. (PVT) – GSHP [45]

172 Because of inherent uncertainties and nonlinearities, all of the mentioned hybrid systems
 173 suffer from issues related to control. This has motivated researchers to find new control methods
 174 such as fuzzy logic (FL) controllers [45] and model predictive control (MPC) [46].

175 3.2. Integration of a Cooling Tower into the Geothermal System

176 It has been shown that it is advantageous to incorporate a cooling tower with the ground
 177 source heat pump (as shown in Fig. 7) to improve the cooling efficiency [19]. This hybrid system is
 178 able to maintain soil thermal balance such that the annual overall COP of the system was found to
 179 be 3.96 (3.93 for cooling and 4.09 for heating) [47]. The capacity of the cooling tower needs to be

180 chosen taking into consideration the difference between peak and average load values or the cooling
181 load percentages [48, 49]. Simulation models have shown that the cooling tower needs to be
182 activated two years after initial heat pump operation. An optimal auxiliary cooling ratio (ACR)
183 needs to be chosen based on the system's configuration (as demonstrated in Fig. 8) [50].

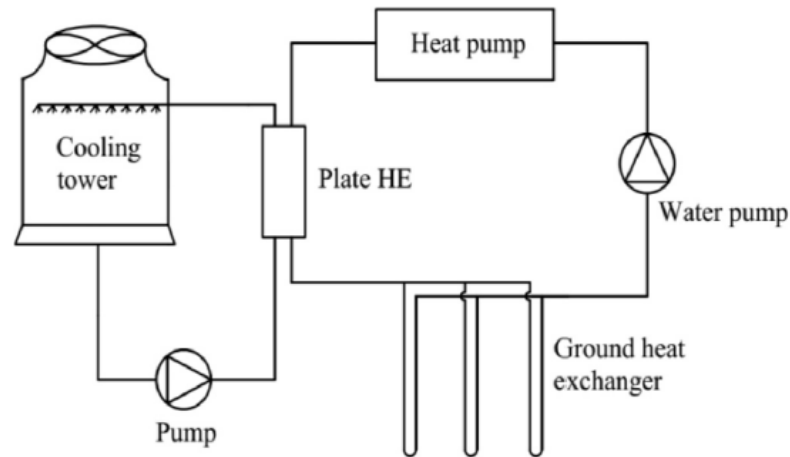

184
185

Fig. 7. GSHP Coupled with a Cooling Tower [51]

186 It has been recommended in the literature that the cooling tower be integrated in a serial
187 configuration (as depicted in Fig. 8) to avoid heat accumulation [52]. In addition, it is necessary to
188 keep the temperature of the water circulating in the cooling tower as low as possible in order to
189 increase the coefficient of performance (COP) [53]. If the cooling load is very high for a standard
190 cooling tower, then a traditional HVAC system can be added to meet the cooling demand [54]. It is
191 also possible to incorporate a second cooling tower that has the same capacity as the ground heat
192 exchanger to serve as an alternator or accumulator [55].

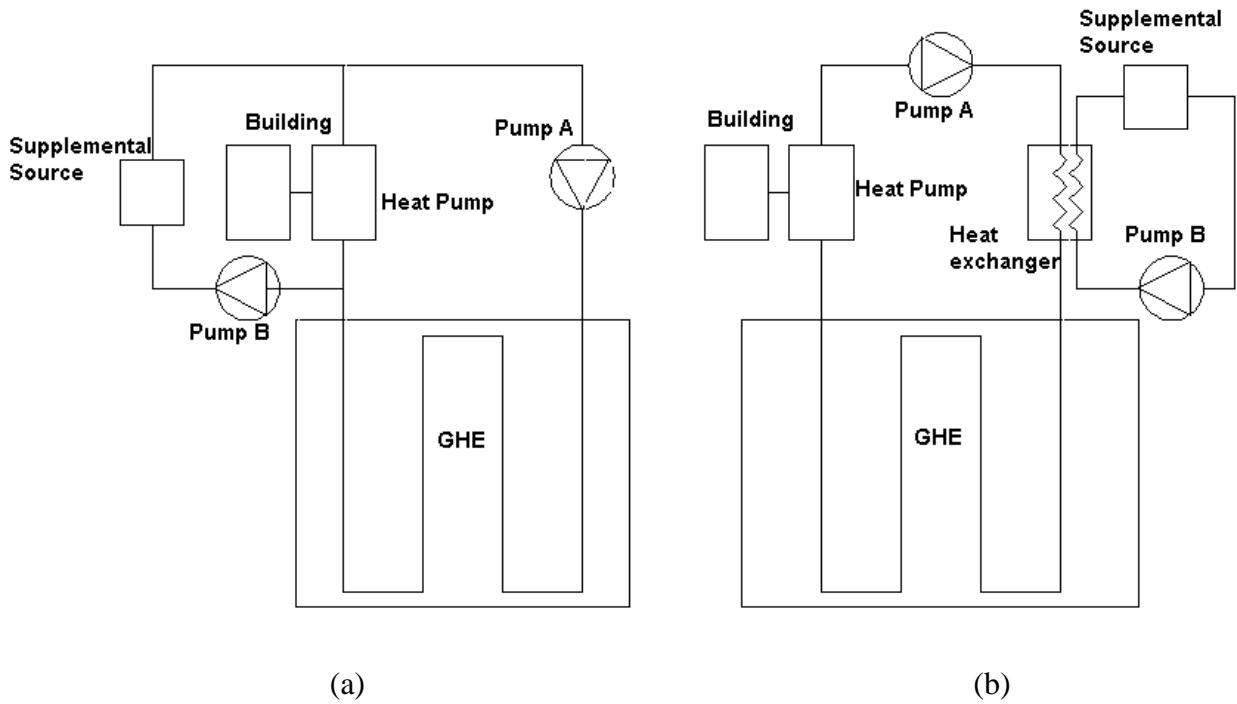

Fig. 8. Parallel (a) vs. Serial (b) Hybrid GSHP Configurations

193

194

195

196

197

198

199

200

201

After studying three different strategies for controlling the geothermal-CT system, researchers have determined that the most optimal was the wet bulb temperature control method. This method is based on the difference between outlet fluid temperature and the temperature of wet bulb [47]. The aim of this method is to make full use of heat exchange between air and soil [56]. It concentrates on deriving the most benefit from ambient capacity by prioritizing the use of ambient air as the cooling source. Artificial Neural Network (ANN) models were developed to predict the temperature of the water existing the GHE in comparison to that of the cooling tower. The ANN showed an absolute error of about 0.2 °C [57].

202

203

204

205

206

207

208

Another control method that has been suggested for hybrid geothermal-CT systems is extremum seeking control (ESC) [51]. This feedback based method (depicted in Fig. 9) is based on a comparison between the total power consumption, flow rate entering the CT, and pump speed. ESC has been shown to provide 9.3% energy savings as compared to other methods. This method will be very helpful in applications where the system consists of multiple bore hole exchangers. In such a system, it would be advisable to normally operate only some of the BHEs and limit operation of all BHEs together to peak load periods only [58].

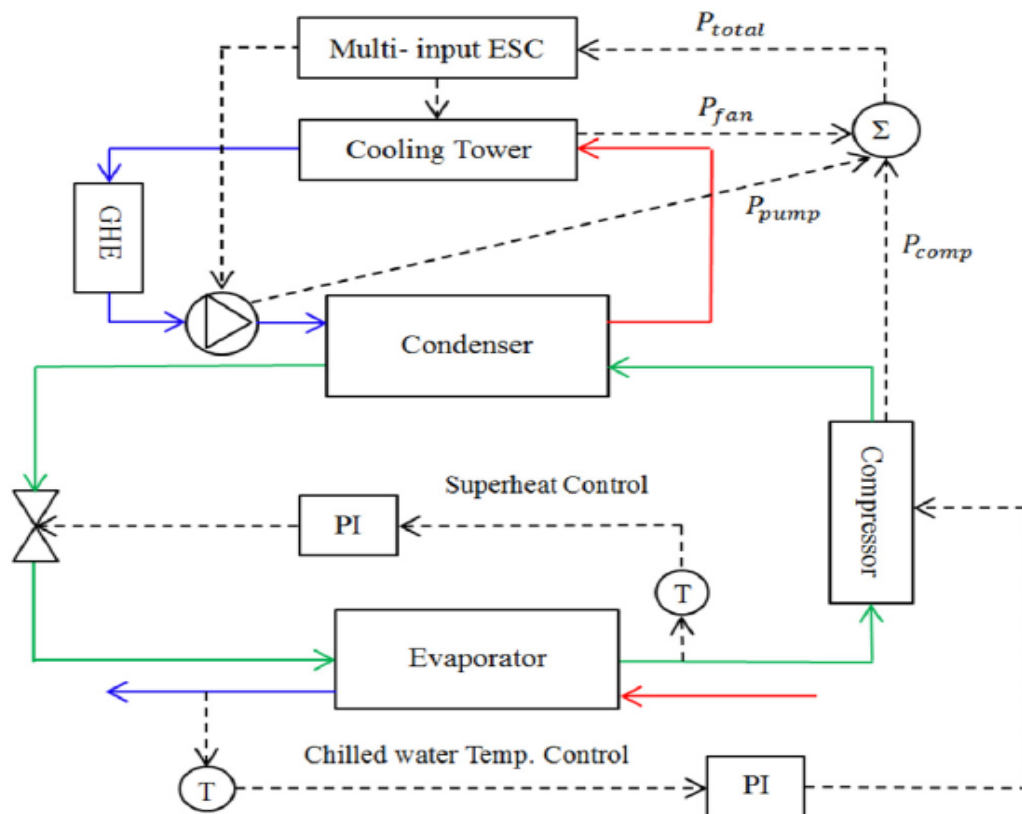

209
210 **Fig. 9.** ESC Control for Optimizing Efficiency of HGSHP System [51]

211 3.3. Less-common Hybrid Geothermal Systems

212 There are some less common hybridization techniques that can integrate geothermal energy
 213 with other sources of energy. For example, it is possible to integrate geothermal with waste heat
 214 recovery (another source of low grade energy) in an electricity generation system. Another example
 215 would be the injection of industrial waste heat into geothermal boreholes. This integration exploits
 216 the thermal storage characteristics of the boreholes and allows the extraction of waste energy
 217 exhausted by industrial processes.

218 A geothermal installation can be integrated into an existing coal fired power plant to
 219 improve efficiency and lower costs. The geothermal system can be used to preheat the boiler's feed
 220 water and can also be used as a carbon capture storage. Researchers have determined that a serial
 221 configuration for geothermal preheating is better at temperatures below 140 °C [59]. A detailed
 222 analysis of available conditions with regards to coal sufficiency and availability of geothermal hot
 223 water are needed before such a system can be contemplated [60]. Another integration can see the

224 utilization of the coal plant for electricity generation and the geothermal system for providing
 225 additional capacity to meet high heating demands [61, 62].

226 Geothermal energy can be used to preheat the organic fluid in a dual-fluid biomass system
 227 to achieve the highest possible output power (see Fig. 10) [63]. Researchers have determined that it
 228 is advisable to integrate a pre-heater and evaporator into the geothermal system to achieve the
 229 combined heat and power system improvements [64].

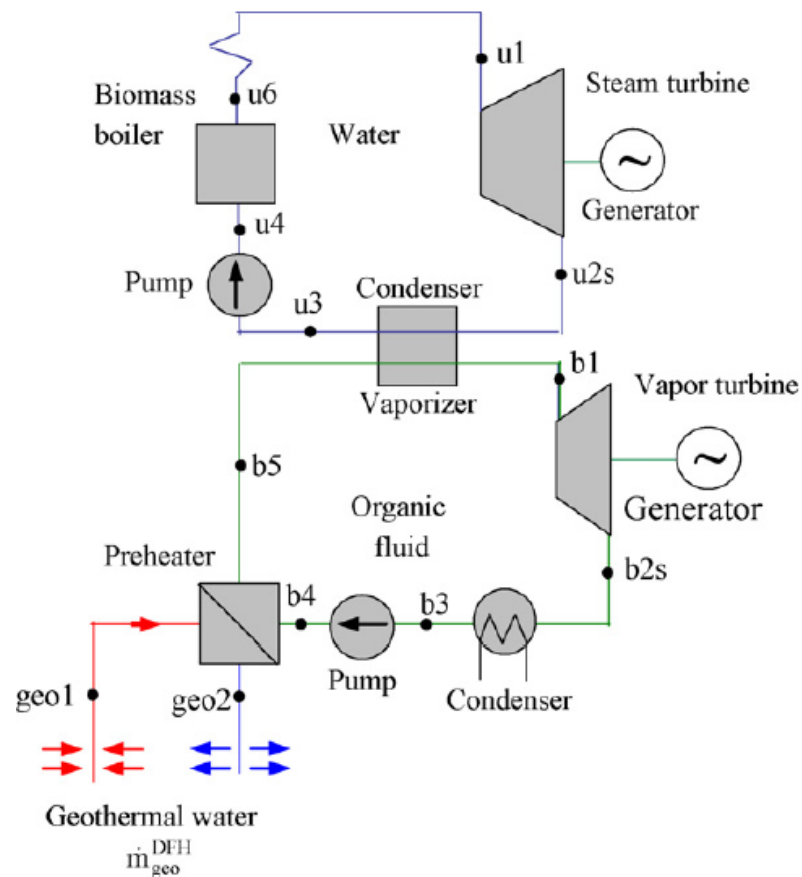

230
 231 **Fig. 10. Dual Fluid Hybrid Geothermal-Biomass Power Plant [63]**

232 One of the main issues affecting geothermal sourced heat pumps is the thermal imbalance. It
 233 has been shown that increasing the size of the heat exchanger can alleviate this issue. However, this
 234 may not be always feasible if the available space is limited. If the load is cooling dominated, then a
 235 chiller can be integrated into the geothermal system to improve the system's performance [65].
 236 Adequate consideration should be given to factors affecting the chiller's design such as required
 237 cooling, compressor efficiency, and climate conditions.

238 A geothermal system can be integrated with a floor cooling system to provide a secondary
239 cooling source [66]. The geothermal system would provide elimination of the floor condensation
240 due to excessive heat that would be generated if the floor radiator is used by itself.

241 Several studies have shown that hybrid systems integrating geothermal energy into existing
242 energy systems can provide improvements in efficiency as well as economics. P. Cui et al. have
243 shown that coupling a geothermal source with an electric heater could produce 3.4% savings in
244 energy used for heating and provision of domestic hot water [67].

245 Various studies have been performed to compare the performance of traditional geothermal
246 systems with hybrids. It was shown that it would be more beneficial to control the temperature of
247 the fluid entering the system when a geothermal system is integrated with a gas boiler and electric
248 air-conditioning system [68]. In [61], a COP of 2.79 was achieved while combining the gas boiler
249 with the GSHP to provide heating. On the other hand, it would be more beneficial to vary the
250 temperature of the fluid exiting the system when a geothermal system is integrated with a cooling
251 tower and a boiler [69].

252 **4. Discussion**

253 It has been found that it is best to use geothermal energy in hybrid systems. The
254 combination of geothermal energy with other sources provides various advantages especially
255 associated with cost of energy. Table 1 highlights the advantages and disadvantages of hybrids as
256 compared to conventional geothermal systems.

Table 1: Advantages/Disadvantages of Geothermal Hybrids

Advantages	Disadvantages
Low energy consumption	More complex
Lower cost of electricity	Control problems
Support higher peak loads	Connection troubles
Low capital cost	
Low operating cost	
No ground fouling	
Smaller bore field area required	

258

259 There has been increasing interest in research related to the hybridization of geothermal
 260 energy systems. Fig. 11 presents the trend of publications in the literature related to hybrid
 261 geothermal systems. It can be seen that interest in such systems has increased tremendously during
 262 the past five to six years.

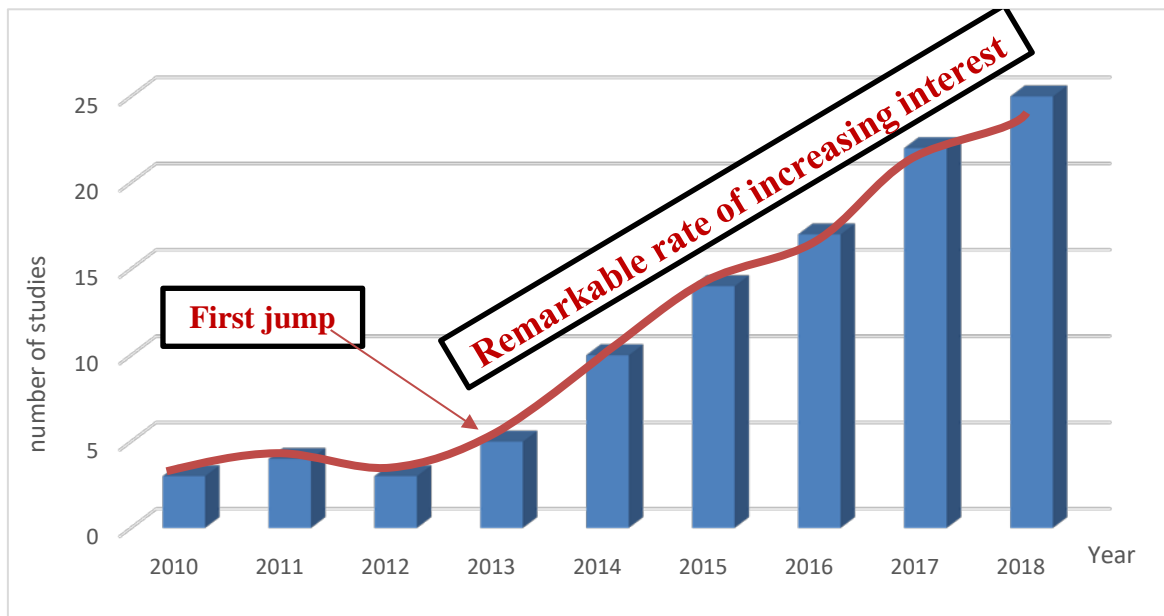

Fig. 11. Evolution of Research in Hybrid Geothermal System

263
264

265

266 Hybrid systems involving geothermal energy are capable of providing different forms of
 267 energy. The diagram in Fig. 12 shows that hybrid geothermal systems are utilized mostly in the
 268 form of heat pumps with approximately equal share (44% each) for heating and cooling
 269 applications. The remaining 12% of hybrids reported in the literature are utilized for generation of

270 electrical energy. The tendency to use these systems for thermal applications (heating and cooling)
271 is directly related to the thermal nature of the energy source.

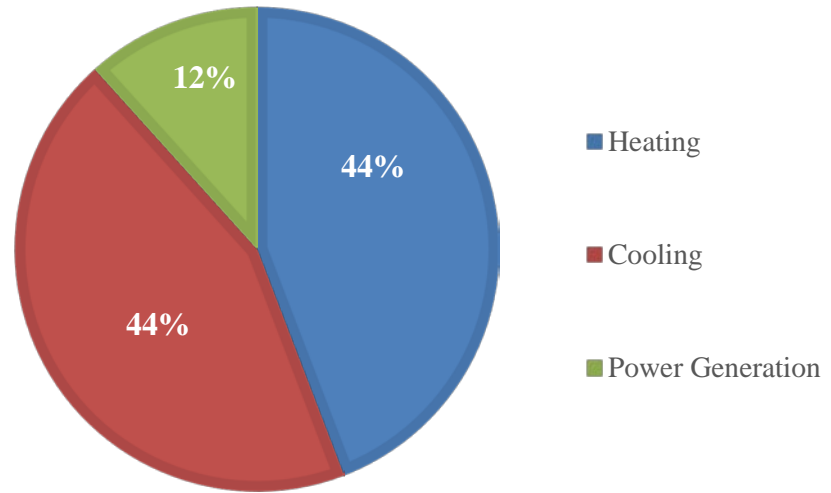

272 **Fig. 12.** Different Applications of Geothermal Hybrids
273

274

275 The previous section discussed numerous possible integrations of geothermal and traditional
276 or renewable energy systems. These combinations depend on many factors including resource
277 availability, environmental effects, desired performance, energy price target, capital costs,
278 operational costs, etc. The diagram in Fig. 13 shows the prevalence of the different types of systems
279 integrated with geothermal installations as reported in the literature. The most common combination
280 is geothermal-solar (about 45% of reported systems) followed by geothermal with a cooling tower
281 (about 30%) of systems.

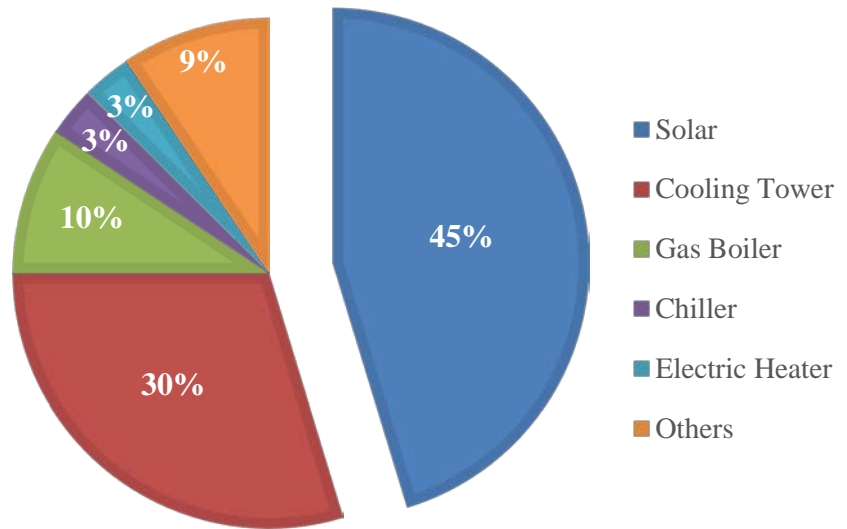

Fig. 13. Types of Systems Integrated into Geothermal Hybrids

282
283

284 There are several factors that could affect the geothermal hybrid system's efficiency and
 285 economic feasibility (see Fig. 14). This depends highly on the consistency between the ground and
 286 the other source used in both cases; power generation and heat pump. That's why it is very
 287 important to pre-study the two combined sources to check out if they could fit as one system from a
 288 thermodynamic point of view while examining the energy that could be generated with respect to
 289 time. This will highlight the expected problems that could mainly be solved by the help of energy
 290 storage systems. Actually, the initial and operating costs vary significantly from one country to the
 291 other based on the availability and abundance of energy sources and equipment.

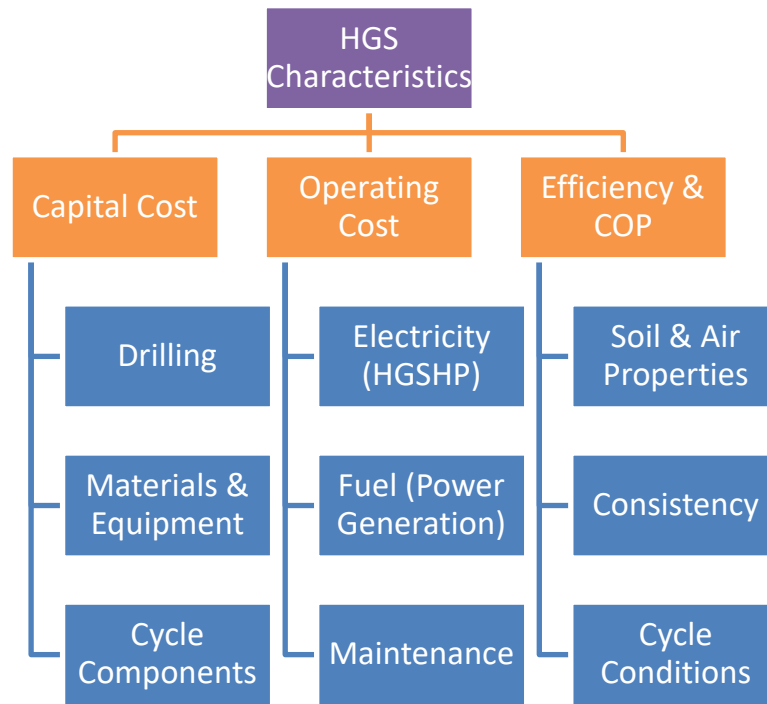

Fig. 14. Factors affecting the HGS characteristics

Recommendations

Based on the literature, it is recommended first to determine the dominant load (cooling, heating or power) in order to specify the preferable supplementary source in addition to the geothermal one. With this in mind, geothermal energy is prioritized over the other energy sources while avoiding thermal imbalance or heat accumulation. Moreover, the supporting source must be highly abundant and has low impact on the environment. Therefore, increasing renewable energy and waste heat recovery utilizations is the most favorable method to encourage people toward ecofriendly systems.

5. Keys for Future Work

Nowadays hybrid system design and development is one of the most significant areas of contribution towards the increased utilization of renewable energy. There is a lot of room where significant research contributions can be made. The following are some key areas for further investigation:

- 307 1. Potential of specific types of hybrid geothermal systems and especially the most common
308 integrations such as geothermal and solar.
- 309 2. Hybrid system optimizations.
- 310 3. New hybrid geothermal system combinations such as the integration of geothermal and wind
311 systems or the integration of geothermal and wave energy systems.

312 **6. Conclusion**

313 The use of renewable energy sources helps in reducing pollution and gas emissions
314 associated with traditional fossil based fuels. In particular, geothermal energy has not been reported
315 to have any significant negative impact. Geothermal energy is characterized by an almost steady
316 supply as compared to the intermittent and fluctuating nature of most other types of renewable
317 energy sources. However, geothermal energy is considered a low grade source of energy and cannot
318 independently support high load applications. Therefore, hybrid systems have been studied to
319 overcome the inherent weakness of geothermal systems. In this work we have discussed numerous
320 integration possibilities of geothermal into hybrid systems. We have shown that geothermal can be
321 integrated with solar energy systems, cooling towers, gas boilers, biomass reactors, electric heaters
322 and chillers, among others.

323 A review of the available literature on geothermal hybrids has shown significant growth in
324 interest since about 2013. The literature showed that the most frequent combination involved
325 geothermal and solar energies. This was followed by geothermal systems integrated with a cooling
326 tower. Hybrid systems have been shown to be utilized for heating and cooling with equal
327 proportions (about 44% each) and to a much lesser extent for power generation (12%). The
328 comparison between the different HGSs showed that each system has its own characteristics.
329 Definitely, the combination of geothermal energy with other renewable sources is the most
330 preferable hybridization followed by waste heat recovery and especially from an environmental
331 point of view. On the other hand, it is quite important to mention that the efficiency, COP and plant

332 capital and operating costs aren't only related to the energy sources used. There are several other
333 factors such as soil properties, ambient conditions, drilling cost, materials, equipment and cycle
334 conditions.

335 The main deterrent against the implementation of geothermal hybrids is control complexity.
336 When different energy sources are combined into a hybrid system, a flexible adaptive control
337 method should be selected to maximize the overall energy production. The control method should
338 take into consideration the characteristics of each energy source. This is the most crucial aspect of
339 the integration problem and this is where research effort is significantly lacking.

340 **References**

341

- [1] B. Mullan, J. Haqq-Misra, Population growth, energy use, and the implications for the search for extraterrestrial intelligence, *Futures*, Volume 106, 2019, Pages 4-17, ISSN 0016-3287, <https://doi.org/10.1016/j.futures.2018.06.009>.
- [2] World Health Organization, "WHO News Release," 02 05 2018. [Online]. Available: <https://www.who.int/news-room/detail/02-05-2018-9-out-of-10-people-worldwide-breathe-polluted-air-but-more-countries-are-taking-action>. [Accessed 13 01 2019].
- [3] Peter Bayer, Guillaume Attard, Philipp Blum, Kathrin Menberg, The geothermal potential of cities, *Renewable and Sustainable Energy Reviews*, Volume 106, 2019, Pages 17-30, ISSN 1364-0321, <https://doi.org/10.1016/j.rser.2019.02.019>.
- [4] Yuanlong Cui, Jie Zhu, Ssennoga Twaha, Junze Chu, Hongyu Bai, Kuo Huang, Xiangjie Chen, Stamatis Zoras, Zohreh Soleimani, Techno-economic assessment of the horizontal geothermal heat pump systems: A comprehensive review, *Energy Conversion and Management*, Volume 191, 2019, Pages 208-236, ISSN 0196-8904, <https://doi.org/10.1016/j.enconman.2019.04.018>.
- [5] Georgios Florides, Soteris Kalogirou, Ground heat exchangers—A review of systems, models and applications, *Renewable Energy*, Volume 32, Issue 15, 2007, Pages 2461-2478, ISSN 0960-1481, <https://doi.org/10.1016/j.renene.2006.12.014>.
- [6] Daniel Adamovský, Pavel Neuberger, Radomír Adamovský, Results of operational verification of vertical ground heat exchangers, *Energy and Buildings*, Volume 152, 2017, Pages 185-193, ISSN 0378-7788, <https://doi.org/10.1016/j.enbuild.2017.07.015>.
- [7] Kejuan Wei; Wenxin Li; Jiarong Li; Yong Wang; Lu Zhang, Study on a design method for hybrid ground heat exchangers of ground-coupled heat pump system, *International Journal of Refrigeration*, Accepted manuscript. doi:10.1016/j.ijrefrig.2016.12.020.
- [8] Diego Moya, Juan Paredes, Prasad Kaparaju, Technical, financial, economic and environmental pre-feasibility study of geothermal power plants by RETScreen – Ecuador's case study, *Renewable and Sustainable Energy Reviews*, Volume 92, 2018, Pages 628-637, ISSN 1364-0321, <https://doi.org/10.1016/j.rser.2018.04.027>.
- [9] Francesco Tinti, Alberto Barbaresi, Daniele Torreggiani, Davide Brunelli, Marco Ferrari, Andrea Verdecchia, Emanuele Bedeschi, Patrizia Tassinari, Roberto Bruno, Evaluation of efficiency of hybrid geothermal basket/air heat pump on a case study winery based on experimental data, *Energy and Buildings*, Volume 151, 2017, Pages 365-380, ISSN 0378-7788, <https://doi.org/10.1016/j.enbuild.2017>.
- [10] Benjamin Hénault; Philippe Pasquier; Michaël Kummert, Financial optimization and design of hybrid ground-coupled heat pump systems, *Applied Thermal Engineering*, 93 (2015) 72-82. doi:10.1016/j.applthermaleng.2015.09.088.

- [11] Scott Hackel; Amanda Pertzborn, Effective design and operation of hybrid ground-source heat pumps: Three case studies, *Energy & Buildings*, 43 (2011) 3497-3504. doi:10.1016/j.enbuild.2011.09.014.
- [12] Wei Wu; Xianting Li; Tian You; Baolong Wang; Wenxing Shi, Hybrid ground source absorption heat pump in cold regions: Thermal balance keeping and borehole number reduction, *Applied Thermal Engineering*, 90 (2015) 322-334. doi:10.1016/j.applthermaleng.2015.07.014.
- [13] Nikola Kuzmic; Ying Lam E. Law; Seth B. Dworkin, Numerical heat transfer comparison study of hybrid and non-hybrid ground source heat pump systems, *Applied Energy*, 165 (2016) 919-929. doi:10.1016/j.apenergy.2015.12.122.
- [14] M. Alavy, H. V. Nguyen, W. H. Leong and S. B. Dworkin, "A methodology and computerized approach for optimizing hybrid ground source heat pump system design," *Renewable Energy*, vol. 57, pp. 404-415, September 2013.
- [15] A. A. Alaica and S. B. Dworkin, "Characterizing the effect of an off-peak ground pre-cool control strategy on hybrid ground source heat pump systems," *Energy & Buildings*, vol. 137, pp. 46-59, February 2017.
- [16] Zishu Qi; Qing Gao; Yan Liu; Y.Y. Yan; Jeffrey D. Spitler, Status and development of hybrid energy systems from hybrid ground source heat pump in China and other countries, *Renewable and Sustainable Energy Reviews*, 29 + (2013) 37-51. doi:10.1016/j.rser.2013.08.059.
- [17] Man Yi, Yang Hongxing, Fang Zhaohong, Study on hybrid ground-coupled heat pump systems, *Energy and Buildings* 40 (2008) 2028–2036, doi:10.1016/j.enbuild.2008.05.010.
- [18] Tian You; Baolong Wang; Wei Wu; Wenxing Shi; Xianting Li, Performance analysis of hybrid ground-coupled heat pump system with multi-functions, *Energy Conversion and Management*, 92 (2015) 47-59. doi:10.1016/j.enconman.2014.12.036.
- [19] Joo Seong Lee; Honghee Park; Yongchan Kim, Transient performance characteristics of a hybrid ground-source heat pump in the cooling mode, *Applied Energy*, 123 (2014) 121-128. doi:10.1016/j.apenergy.2014.02.056.
- [20] Suresh Kumar Soni; Mukesh Pandey; Vishvendra Nath Bartaria, Hybrid ground coupled heat exchanger systems for space heating/cooling applications_ A review, *Renewable and Sustainable Energy Reviews*, 60 + (2016) 724-738. doi:10.1016/j.rser.2016.01.125.
- [21] Masih Alavy; Seth B. Dworkin; Wey H. Leong, A design methodology and analysis of combining multiple buildings onto a single district hybrid ground source heat pump system, *Renewable Energy*, 66 (2014) 515-522. doi:10.1016/j.renene.2013.12.030.
- [22] K. Allaerts; M. Coomans; R. Salenbien, Hybrid ground-source heat pump system with active air source regeneration, *Energy Conversion and Management*, 90 (2015) 230-237. doi:10.1016/j.enconman.2014.11.009.
- [23] Hiep V. Nguyen; Ying Lam E. Law; Masih Alavy; Philip R. Walsh; Wey H. Leong; Seth B. Dworkin, An analysis of the factors affecting hybrid ground-source heat pump installation potential in North America, *Applied Energy*, 125 (2014) doi:10.1016/j.apenergy.2014.03.044.
- [24] Valentin Trillat-Berdal, Bernard Souyri, Gilbert Achard, Coupling of geothermal heat pumps with thermal solar collectors, In *Applied Thermal Engineering*, Volume 27, Issue 10, 2007, Pages 1750-1755, ISSN 1359-4311, <https://doi.org/10.1016/j.applthermaleng.2006.07.022>.
- [25] Enyu Wang; Alan S. Fung; Chengying Qi; Wey H. Leong, Performance prediction of a hybrid solar ground-source heat pump system, *Energy & Buildings*, 47 (2011) 600-611. doi:10.1016/j.enbuild.2011.12.035.
- [26] Nima Bonyadi, Evan Johnson, Derek Baker, Technoeconomic and exergy analysis of a solar geothermal hybrid electric power plant using a novel combined cycle, *Energy Conversion and Management*, Volume 156, 2018, Pages 542-554, ISSN 0196-8904, <https://doi.org/10.1016/j.enconman.2017>.
- [27] Martina Ciani Bassetti, Daniele Consoli, Giovanni Manente, Andrea Lazzaretto, Design and off-design models of a hybrid geothermal-solar power plant enhanced by a thermal storage, *Renewable Energy*, 2017, , ISSN 0960-1481, <https://doi.org/10.1016/j.renene.2017.05.078>.
- [28] Pei-Xue Jiang, Fu-Zhen Zhang, Rui-Na Xu, Thermodynamic analysis of a solar-enhanced geothermal hybrid power plant using CO₂ as working fluid, *Applied Thermal Engineering*, Volume 116, 2017, Pages 463-472, ISSN 1359-4311, <https://doi.org/10.1016/j.applthermaleng.2016.12.086>.

- [29] Hadi Ghasemi; Elysia Sheu; Alessio Tizzanini; Marco Paci; Alexander Mitsos, Hybrid solar - geothermal power generation: Optimal retrofitting, *Applied Energy*, 131 (2014) 158-170. doi:10.1016/j.apenergy.2014.06.010.
- [30] Alvaro Lentz, Rafael Almanza, Solar-geothermal hybrid system, *Applied Thermal Engineering* 26 (2006) 1537-1544, doi:10.1016/j.applthermaleng.2005.12.008.
- [31] Marco Astolfi; Luca Xodo; Matteo C. Romano; Ennio Macchi, Technical and economical analysis of a solar - geothermal hybrid plant based on an Organic Rankine Cycle, *Geothermics*, 40 (2010) 58-68. 10.1016/j.geothermics.2010.09.009.
- [32] Mohammad Ayub; Alexander Mitsos; Hadi Ghasemi, Thermo-economic analysis of a hybrid solar-binary geothermal power plant, *Energy*, 87 (2015) 326-335. doi:10.1016/j.energy.2015.04.106.
- [33] A. Acutta, F. Lara, P. Rosales, J. Suastegui, N. Velázquez, A. Ruelas, Impact of a vertical geothermal heat exchanger on the solar fraction of a solar cooling system, In *International Journal of Refrigeration*, Volume 76, 2017, Pages 63-72, ISSN 0140-7007 , <https://doi.org/10.1016/j.ijrefrig.2017.02.007>.
- [34] Min Guo; Nairen Diao; Yi Man; Zhaohong Fang, Research and development of the hybrid ground-coupled heat pump technology in China, *Renewable Energy*, Corrected proof. doi:10.1016/j.renene.2015.08.021.
- [35] Jérôme de La Bernardie, Jean-Raynald de Dreuzy, Olivier Bour, Hervé Lesueur, Synthetic investigation of thermal storage capacities in crystalline bedrock through a regular fracture network as heat exchanger, *Geothermics*, Volume 77, 2019, Pages 130-138, IS SN 0375-6505, <https://doi.org/10.1016/j.geothermics.2018.08.010>.
- [36] Cheng Zhou; Elham Doroodchi; Behdad Moghtaderi, An in-depth assessment of hybrid solar-geothermal power generation, *Energy Conversion and Management*, 74 (2013) 88-101. doi:10.1016/j.enconman.2013.05.014.
- [37] Jose Miguel Cardemil; Felipe Cortés; Andrés Díaz; Rodrigo Escobar, Thermodynamic evaluation of solar-geothermal hybrid power plants in northern Chile, *Energy Conversion and Management*, 123 (2016) 348-361. doi:10.1016/j.enconman.2016.06.032.
- [38] Saeid Mohammadzadeh Bina, Saeid Jalilinasrabady, Hikari Fujii, Exergoeconomic analysis and optimization of single and double flash cycles for Sabalan geothermal power plant, *Geothermics*, Volume 72, 2018, Pages 74-82, ISSN 0375-6505, <https://doi.org/10.1016/j.geothermics.2017.10.013>.
- [39] Jongmin Choi; Byun Kang; Honghyun Cho, Performance comparison between R22 and R744 solar-geothermal hybrid heat pumps according to heat source conditions, *Renewable Energy*, 71 (2014) 414-424. doi:10.1016/j.renene.2014.05.057.
- [40] Zhequan Jin; Trygve M. Eikevik; Petter Neksa; Armin Hafner, Investigation on CO₂ hybrid ground-coupled heat pumping system under warm climate, *International Journal of Refrigeration*, 62 (2016) 145-152. doi:10.1016/j.ijrefrig.2015.10.005.
- [41] Zhequan Jin; Trygve M. Eikevik; Petter Neksa; Armin Hafner, A steady and quasi-steady state analysis on the CO₂ hybrid ground-coupled heat pumping system, *International Journal of Refrigeration*, Accepted manuscript. doi:10.1016/j.ijrefrig.2017.01.029.
- [42] Wonseok Kim; Jongmin Choi; Honghyun Cho, Performance analysis of hybrid solar-geothermal CO₂ heat pump system for residential heating, *Renewable Energy*, 50 (2013) 596-604. doi:10.1016/j.renene.2012.07.020.
- [43] Francesco Calise; Massimo Dentice d'Accadia; Adriano Macaluso; Antonio Piacentino; Laura Vanoli, Exergetic and exergoeconomic analysis of a novel hybrid solar - geothermal polygeneration system producing energy and water, *Energy Conversion and Management*, 115 (2016) 200-220. doi:10.1016/j.enconman.2016.02.029.
- [44] Osamah Siddiqui, Haris Ishaq, Ibrahim Dincer, A novel solar and geothermal-based trigeneration system for electricity generation, hydrogen production and cooling, *Energy Conversion and Management*, Volume 198, 2019, 111812, ISSN 0196-8904, <https://doi.org/10.1016/j.enconman.2019.111812>.
- [45] S. Andrew Putrayudha; Eun Chul Kang; E. Evgueniy; Y. Libing; Euy Joon Lee, A study of photovoltaic/thermal (PVT)-ground source heat pump hybrid system by using fuzzy logic control, *Applied Thermal Engineering*, Accepted manuscript. doi:10.1016/j.applthermaleng.2015.06.019.

- [46] S. Antonov; L. Helsen, Robustness analysis of a hybrid ground coupled heat pump system with model predictive control, *Journal of Process Control* , 47 (2016) 191-200. doi:10.1016/j.jprocont.2016.08.009.
- [47] Zongwei Han; Xiaomei Ju; Xiao Ma; Yanhong Zhang; Min Lin, Simulation of the performance of a hybrid ground-coupled heat pump system on the basis of wet bulb temperature control, *Applied Thermal Engineering*, 108 (2016) 980-988. doi:10.1016/j.applthermaleng .2016.07.171.
- [48] Yi Man; Hongxing Yang; Jinggang Wang, Study on hybrid ground-coupled heat pump system for air-conditioning in hot-weather areas like Hong Kong, *Applied Energy* 87 (2010) 2826–2833, doi:10.1016/j.apenergy.2009.04.044.
- [49] Z. Sagia; C. Rakopoulos; E. Kakaras, Cooling dominated Hybrid Ground Source Heat Pump System application, *Applied Energy*, 94 (2012) 41-47. doi:10.1016/j.apenergy.2012.01.031.
- [50] Wenzhi Cui; Shiyu Zhou; Xiangyang Liu, Optimization of design and operation parameters for hybrid ground-source heat pump assisted with cooling tower, *Energy & Buildings*, 99 (2015) 253-262. doi:10.1016/j.enbuild.2015.04.034.
- [51] Bin Hu; Yaoyu Li; Baojie Mu; Shaojie Wang; John E. Seem; Feng Cao, Extremum seeking control for efficient operation of hybrid ground source heat pump system, *Renewable Energy*, 86 (2016) 332-346. doi:10.1016/j.renene.2015.07.092.
- [52] Joo Seong Lee; Kang Sub Song; Jae Hwan Ahn; Yongchan Kim, Comparison on the transient cooling performances of hybrid ground-source heat pumps with various flow loop configurations, *Energy*, Corrected proof. doi:10.1016/j.energy.2015.01.076.
- [53] Luthfi I. Lubis; Mehmet Kanoglu; Ibrahim Dincer; Marc A. Rosen, Thermodynamic analysis of a hybrid geothermal heat pump system, *Geothermics*, 40 (2011) 233-238. doi:10.1016/j.geothermics.2011.06.004.
- [54] Rui Fan; Yan Gao; Li Hua; Xiaoxi Deng; Jie Shi, Thermal performance and operation strategy optimization for a practical hybrid ground-source heat-pump system, *Energy & Buildings*, 78 (2014) 238-247. doi:10.1016/j.enbuild.2014.04.041.
- [55] Jing Yang; Linghong Xu; Pingfang Hu; Na Zhu; Xuepeng Chen, Study on intermittent operation strategies of a hybrid ground-source heat pump system with double-cooling towers for hotel buildings, *Energy & Buildings*, 76 (2014) 506-512. doi:10.1016/j.enbuild.2014.02.061.
- [56] Wenjie Gang; Jinbo Wang; Shengwei Wang, Performance analysis of hybrid ground source heat pump systems based on ANN predictive control, *Applied Energy*, Corrected proof. doi:10.1016/j.apenergy.2014.04.005.
- [57] Wenjie Gang; Jinbo Wang, Predictive ANN models of ground heat exchanger for the control of hybrid ground source heat pump systems, *Applied Energy*, doi:10.1016/j.apenergy.2012.12.031.
- [58] Jin Luo; Haifeng Zhao; Jia Jia; Wei Xiang; Joachim Rohn; Philipp Blum, Study on operation management of borehole heat exchangers for a large-scale hybrid ground source heat pump system in China, *Energy*, 123 (2017) 340-352. doi:10.1016/j.energy.2017.01.136.
- [59] Qiang Liu; Linlin Shang; Yuanyuan Duan, Performance analyses of a hybrid geothermal-fossil power generation system using low-enthalpy geothermal resources, *Applied Energy*, 162 (2016) 149-162. doi:10.1016/j.apenergy.2015.10.078.
- [60] Matthias Bruhn, Hybrid geothermal–fossil electricity generation from low enthalpy geothermal resources: geothermal feedwater preheating in conventional power plants, *Energy* 27 (2002) 329–346, doi.org/10.1016/S0360-5442(01)00088-3.
- [61] Zhijian Liu; Wei Xu; Xue Zhai; Cheng Qian; Xi Chen, Feasibility and performance study of the hybrid ground-source heat pump system for one office building in Chinese heating dominated areas, *Renewable Energy*, 101 (2017) 1131-1140. doi:10.1016/j.renene.2016.10.006.
- [62] Kathrin Menberg; Yeonsook Heo; Wonjun Choi; Ryoza Ooka; Ruchi Choudhary; Masanori Shukuya, Exergy analysis of a hybrid ground-source heat pump system, *Applied Energy*, 204 (2017) 31-46. doi:10.1016/j.apenergy.2017.06.076.
- [63] Aleksandra Borsukiewicz-Gozdur, Dual-fluid-hybrid power plant co-powered by low-temperature geothermal water, *Geothermics* 39 (2010) 170–176, doi:10.1016/j.geothermics.2009.10.004.
- [64] Muhsen Habka; Salman Ajib, Investigation of novel, hybrid, geothermal-energized cogeneration plants based on organic Rankine cycle, *Energy*, Corrected proof. doi:10.1016/j.energy.2014.03.114.

- [65] Koenraad F. Beckers; Gloria A. Aguirre; Jefferson W. Tester, Hybrid Ground-Source Heat Pump Systems for Cooling-Dominated Applications: Experimental and Numerical Case-Study of Cooling for Cellular Tower Shelters, *Energy & Buildings*, Accepted manuscript. doi:10.1016/j.enbuild.2018.08.005.
- [66] Yi Man; Hongxing Yang; Jeffrey D. Spitler; Zhaohong Fang, Feasibility study on novel hybrid ground coupled heat pump system with nocturnal cooling radiator for cooling load dominated buildings, *Applied Energy*, 88 (2011) 4160-4171. doi:10.1016/j.apenergy.2011.04.035.
- [67] P. Cui, H. Yang, J. D. Spitler and Z. Fang, "Simulation of hybrid ground-coupled heat pump with domestic hot water heating systems using HVACSIM+," *Energy and Buildings*, vol. 40, no. 9, p. 1731–1736, 2008.
- [68] Hiep V. Nguyen; Ying Lam E. Law; Xiaoyan Zhou; Philip R. Walsh; Wey H. Leong; Seth B. Dworkin, A techno-economic analysis of heat-pump entering fluid temperatures, and CO2 emissions for hybrid ground-source heat pump systems, *Geothermics*, 61 (2016) 24-34. doi:10.1016/j.geothermics.2016.01.013.
- [69] Honghee Park; Joo Seoung Lee; Wonuk Kim; Yongchan Kim, The cooling seasonal performance factor of a hybrid ground-source heat pump with parallel and serial configurations, *Applied Energy*, 102 (2013) 877-884. doi:10.1016/j.apenergy.2012.09.035.

342

343

344