



City Research Online

City St George's, University of London

Citation: Mahmoud, M., Ramadan, M., Naher, S., Pullen, K. R., Ali Abdelkareem, M. & Olabi, A-G. (2021). A review of geothermal energy-driven hydrogen production systems. *Thermal Science and Engineering Progress*, 22, 100854. doi: 10.1016/j.tsep.2021.100854

This is the accepted version of the paper.

This version of the publication may differ from the final published version. To cite this item please consult the publisher's version.

Permanent repository link: <https://openaccess.city.ac.uk/id/eprint/25585/>

Link to published version: <https://doi.org/10.1016/j.tsep.2021.100854>

Copyright and Reuse: Copyright and Moral Rights remain with the author(s) and/or copyright holders. Copies of full items can be used for personal research or study, educational, or not-for-profit purposes without prior permission or charge, unless otherwise indicated, provided that the authors, title and full bibliographic details are credited, a hyperlink and/or URL is given for the original metadata page and the content is not changed in any way. For full details of reuse please refer to [City Research Online policy](#).

A review of geothermal energy-driven hydrogen production systems

Montaser Mahmoud^{1,2}, Mohamad Ramadan^{3,4*}, Sumsun Naher¹, Keith Pullen¹, Mohammad Ali Abdelkareem^{5,6}, Abdul-Ghani Olabi^{5,7}

¹Department of Engineering, School of Mathematics, Computer Science and Engineering, City, University of London, UK

²Lebanese International University, PO Box 146404 Beirut, Lebanon

³International University of Beirut, PO Box 146404 Beirut, Lebanon

⁴Associate member at FCLAB, CNRS, Univ. Bourgogne Franche-Comte, Belfort cedex, France

⁵Sustainable and Renewable Energy Engineering, University of Sharjah, Sharjah, UAE

⁶Chemical Engineering Department, Faculty of Engineering, Minia University, Egypt

⁷Mechanical Engineering and Design, Aston University, School of Engineering and Applied Science, Aston Triangle, Birmingham, B4 7ET, UK

Abstract

This paper presents a review of hydrogen production systems using geothermal energy, showing the importance and potential of this technology in addition to the main obstacles facing this domain. The effect of several parameters was taken into consideration, such as geothermal fluid temperature, water electrolysis temperature, working fluid, and type of power cycle. The different types of geothermal power plants were also compared, namely, flash, binary, flash-binary, recuperative, regenerative, and organic Rankine flash cycles. This study covers a wide range of investigations regarding hydrogen production rate, hydrogen production cost, energetic efficiency, exergetic efficiency, exergetic cost, and electricity generated. Hydrogen production rate is one of the most important mentioned parameters in which it was found to vary from 5.439 kg/h to 13958 kg/h. Multigeneration systems have shown great potential to enhance the overall system's efficiency, leading to reduced production costs. The integration of another energy source was found to be interesting in geothermal-driven hydrogen production systems. This would promote

the adoption of multigeneration system as well as increasing the geothermal fluid's temperature before entering the power cycle.

Keywords: Hydrogen production, Geothermal energy, Energy and exergy efficiency, Cost of hydrogen production.

Nomenclature	
<i>Abbreviations</i>	
AC	absorption chiller
ACS	absorption cooling system
AMIS®	abatement of mercury and hydrogen sulfide (in Italian language)
BTES	borehole thermal energy storage
CCS	carbon capture and storage
EES	Engineering Equation Solver
ESS	energy storage system
ETSC	evacuated tube solar collector
FPSC	flat plate solar collector
GE	geothermal energy
GHE	ground heat exchanger
GIS	geographical information system
GPP	geothermal power plant
GSHP	ground source heat pump
HOMER	hybrid optimization model for electric renewables
HP	heat pump
KC	Kalina cycle
LNG	liquefied natural gas
MGS	multigeneration system
NCG	non-condensable gases
ORC	organic Rankine cycle
ORFC	organic Rankine flash cycle
PEM	proton exchange membrane
PTSC	parabolic trough solar collector
PV	photovoltaic
RC	Rankine cycle
RES	renewable energy source
RO	reverse osmosis
RTV	Rankine-Trough-Vapor
SC	solar collector
VAC	vapor absorption cycle
VTR	Vapor-Trough-Rankine
<i>Subscripts</i>	

c	cooling
e	electricity
en	energy
ex	exergy
h	hydrogen
th	thermal

1. Introduction

Electrical and hybrid energy systems have been going through massive growth in recent years. This has been observed in different sectors, such as in vehicles [1, 2]. Hybridization has shown great potential to improve the efficiency of various energy-related systems. The driver of this approach is mainly to reduce the environmental impact of traditional fossil fuel-based systems. Renewable energy sources (RESs) have been found to be the best alternatives, such as solar [3], wind [4], hydropower [5], and geothermal energy [6]. However, in most cases, RESs are characterized by stochastic and intermittent natures, making the utilization of these sources uncontrollable [7, 8]. This may cause significant fluctuations in the systems' outputs and productivity. Thus, energy storage systems (ESSs) have been developed to stabilize such systems and overcome the mentioned side effects of RESs [9]. ESSs can store the excess of energy and supply it when needed. This helps in decreasing the effect of fluctuations and has potential to provide extra power during peak-time demands. The latter benefit means that ESSs can increase the supplying source's capacity without using additional resources. ESS management has been always passing through continuous developments to cope with the rapid growth of energy-related systems [10, 11]. Management techniques involve the methods needed for transferring energy from one form to another and direct energy storage. For example, in case of excess heat, the system that can be used is either the waste heat recovery [12] or thermal energy storage [13]. In fact, the challenge is to adopt or select the suitable ESS while being eco-friendly, which imposes choosing

storage systems such as mechanical energy storage [14] and hydrogen fuel cell [15]. The former is usually used in short-term applications when a fast response is required and has been frequently used in small grids district systems [16, 17]. It is found mainly in three different forms: flywheel [18], pumped hydro [19], and compressed air [20]. The energy stored in these systems is not transportable, which means that it is used only for immediate and on-site supply. This makes the hydrogen fuel cell the preferable storage technique for being the most controllable system [21, 22]. Nowadays, hydrogen is considered one of the most favorable energy carriers since it could be used for a wide variety of applications while being highly efficient, as shown in Figure 1. Researchers have recently focused on investigating various hydrogen production systems based on RESs [23, 24], fossil fuels [25, 26] and waste treatments [27, 28]. Acar and Dincer [29] compared the different hydrogen production sources from an environmental point of view. The authors deduced that solar energy corresponds to the highest environmental performance while nuclear energy has the lowest. To investigate the effect of hydrogen production systems on the environment, several factors need to be taken into consideration such as water discharge quality, land use, emissions, temperature, construction, maintenance, and lifetime [30, 31]. Indeed, it is highly recommended to produce hydrogen from RES to increase its penetration since RES are more environmentally benign than fossil fuel-based systems. However, it is also necessary to seek the most profitable system from an economic point of view. Before adopting such systems, several parameters need to be taken into consideration, such as the energetic and exergetic efficiencies, cost of production, payback period, and the amount of hydrogen produced per unit of time. Usually, hydrogen production systems are integrated with existing power plants to form cogeneration systems. This means that there are two types of outputs, namely, electric power and hydrogen [32]. This makes the incorporation of hydrogen production an effective way for

enhancing the overall efficiency of the plant. Output diversification is a key method used to extract the maximum possible amount of power from a given source without building a new power plant. Another advantage is to produce beneficial byproducts depending on the reactants involved [33]. For example, in conventional geothermal power plants (GPPs), the heat carried by the geothermal fluid is not totally consumed. Thus, a heat recovery system could be used to extract the remaining power from the fluid just before being reinjected back to the ground. Incidentally, hydrogen production systems such as electrolysis present an attractive solution to recover this heat since it requires electric power and water preheating [34]. This makes geothermal energy (GE) and hydrogen production a perfect combination in terms of economic, environmental, and thermodynamical basis. The GPP can supply electricity to activate the electrolysis process while the geothermal fluid exiting the power plant can be used to preheat the water before entering the electrolyzer.

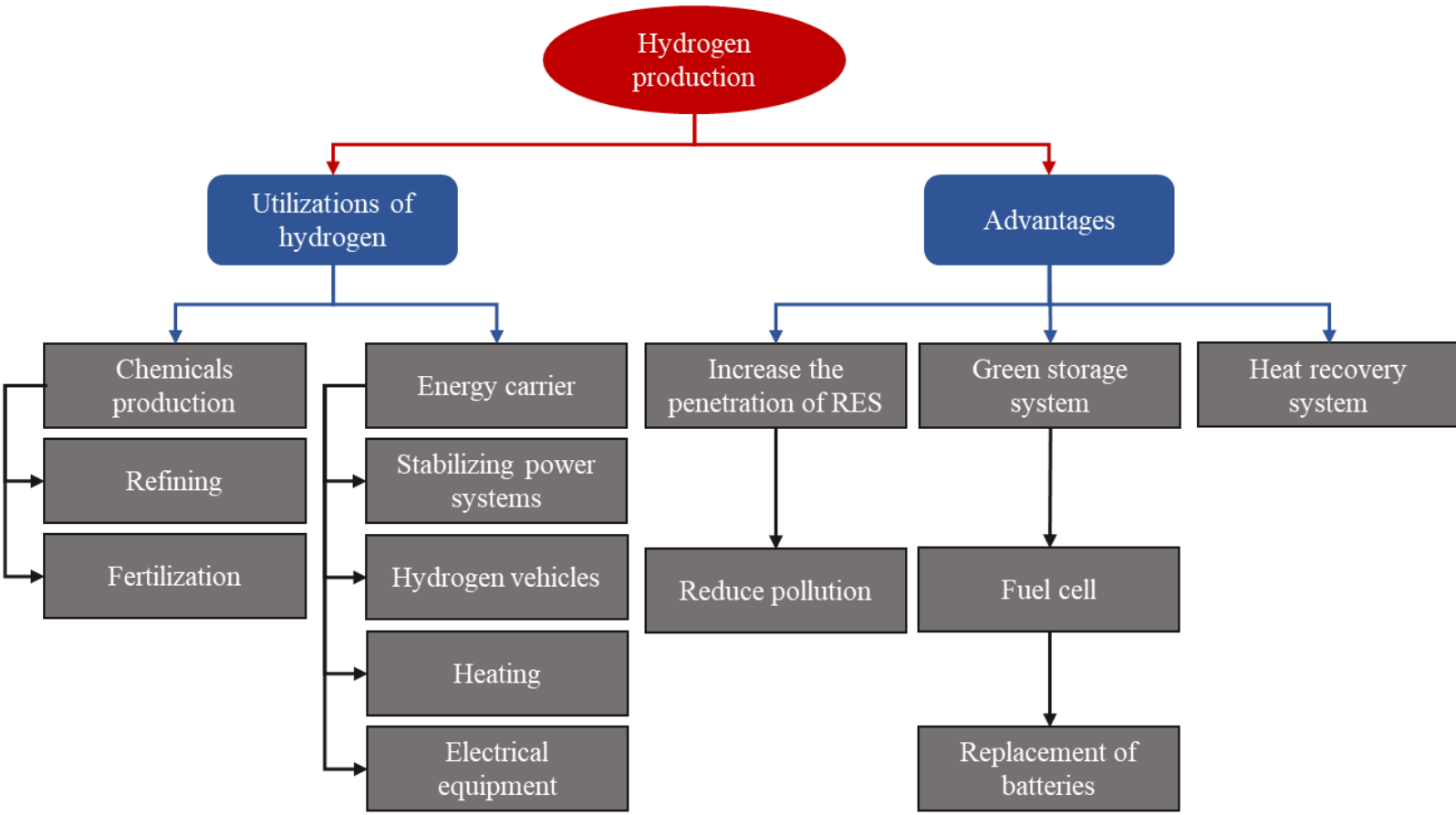

Figure 1: The importance and characteristics of hydrogen production technology

This paper presents the importance and development of hydrogen production technologies with a focus on geothermal-driven systems. It includes the techniques and cycles used for producing hydrogen as well as the most critical parameters affecting these systems, such as working fluid, electrolysis temperature, flow rate, and geothermal fluid temperature. The current study also involves the contribution of hybrid and multigeneration systems (MGSs) including their effects on the overall system’s performance. In addition, the incorporation of the different used cycles will be presented, such as flash and binary cycles. The assessment of the presented systems will be based on the rate of hydrogen production, cost, energetic and exergetic efficiencies.

2. Hydrogen Production Systems

There are several types and treatments for producing hydrogen in which each method depends on the energy source used, such as thermolysis [35, 36], pyrolysis [37, 38], electrolysis [39, 40], and reforming [41, 42]. These systems are mainly based on heating, electricity, and refining. Each system requires specific inputs to produce hydrogen and other types of products. This section will present the different systems that are used to produce hydrogen and their characteristics. Figure 2 shows the main types of hydrogen production techniques, including the inputs and outputs of each method.

Producing hydrogen from fossil fuels and biomass resources occurs at high temperatures by passing through a process known as gasification [43]. The temperature of gasification depends on the reactants, such as coal and organic materials. Combustion is not required in such processes; however, the presence of oxygen or steam is necessary in most cases. Biomass is gasified at temperatures higher than 374°C, known as supercritical water gasification [44]. The obtaining products are mainly H₂ and CO₂:



Photolysis is one of the less commonly used hydrogen production techniques in which it is based on directly utilizing sunlight to break water into hydrogen and oxygen [45]. It has a very low environmental impact compared to other methods; however, it is still under development and researchers are trying to find suitable catalysts for enhancing this process. Ban *et al.* [46] studied the contribution of Ca²⁺ for enhancing photolysis H₂ production. It was found that adding Ca²⁺ is an efficient way for improving photolysis such that the value of hydrogen produced was 2.4 times greater than that without Ca²⁺. Photolysis is usually formed of two consecutive chemical reactions:

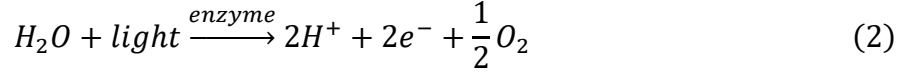

The most commonly used methods of water-splitting are known as electrolysis or electrochemical water splitting [47]. These could be found mainly in two different forms, namely, proton exchange membrane (PEM) electrolysis [48] and alkaline electrolysis [49]. The former requires electricity as an input for activating the splitting process and depends significantly on the water's temperature entering the electrolyzer. Usually, PEM electrolysis utilizes RESs to store energy and resupply it when needed or to transport energy in the form of hydrogen for long distances to be used in vehicles as an example. The following chemical reaction shows the PEM electrolysis process:

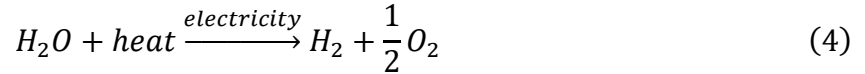

In the case of alkaline water electrolysis, a strong base is usually used as an electrolyte. The following are the cathode and anode half-reactions, respectively:



Hydrocarbon reforming is a hydrogen production technique that is based on changing the structure of some hydrocarbons in the presence of steam to produce hydrogen. One of the most frequently used substances for producing hydrogen is methane [50]. This process requires a steam reforming separator which is responsible for separating methane and steam to produce hydrogen and carbon monoxide. However, to produce pure H₂ and increase its production, a water-gas shift reaction is needed after the first separation allowing the conversion from CO to CO₂:

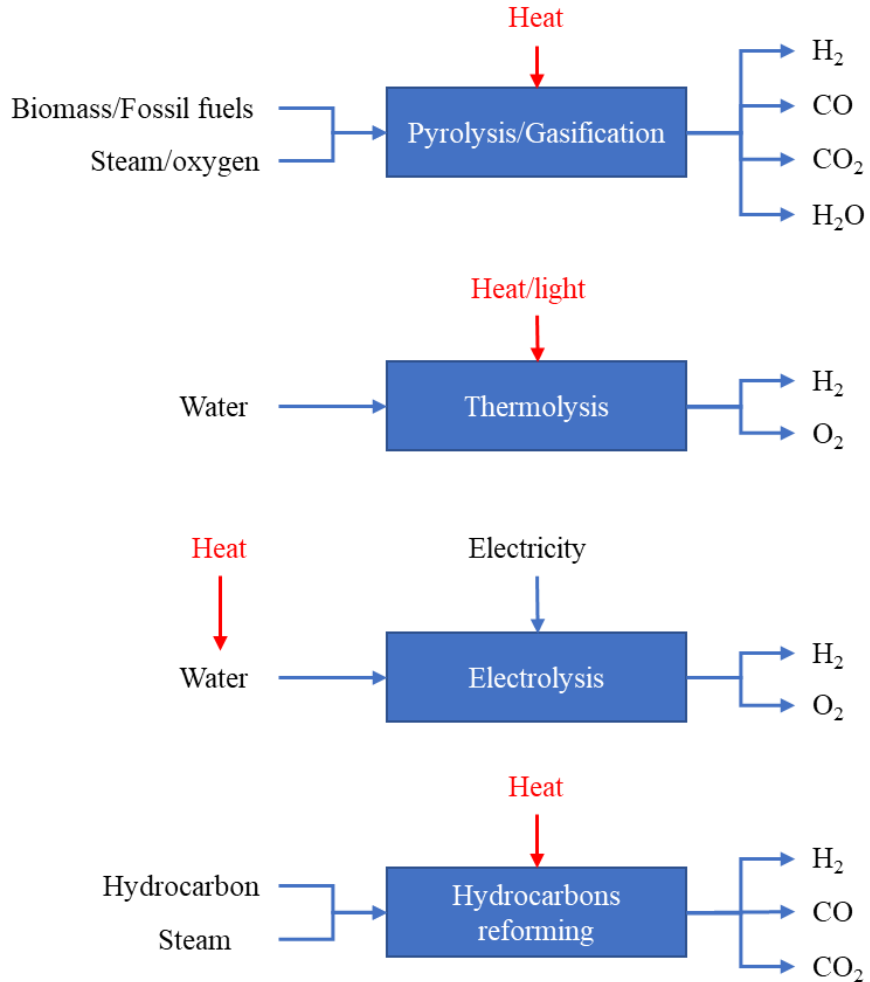

Figure 2: The different types of hydrogen production systems

3. Geothermal Energy

Among all RESs, GE is considered the most stable and reliable source since it is almost independent of ambient conditions [51]. The geothermal system's stability depends on several factors, such as depth, soil properties, load, and grout material. GE could be used in a wide variety of applications such as heating [52], cooling [53], energy storage [54], and power generation [55]

(see Figure 3). GE systems can be classified into shallow and deep geothermal systems with corresponding installations of ground heat exchanger (GHE) and production-injection wells. Heating and cooling using GE are usually performed utilizing a ground source heat pump (GSHP) that is based on the conventional refrigeration cycle which is an upgraded form of the air source heat pump [56]. This requires the installation of a GHE, which has three different configurations that are: vertical [57], horizontal [58], and coiled [59]. The coiled GHE could also be found in the form of spiral/helical and slinky shapes. In shallow GE systems, the GHE must be surrounded by grout material which is responsible for protecting the heat exchanger from being damaged while providing a convenient medium for heat transfer. Thus, the grout must be characterized by high thermal conductivity and mechanical strength. The type of grout material can also affect the required size of GHE and its capital cost. With this regard, phase change materials have been used as modern versions of grout materials to increase the capacity and provide more stability. The installation of both grout and GHE is known as a borehole heat exchanger. The second type of geothermal system used for providing heating/cooling is the earth-air heat exchanger, which is less commonly used [60, 61]. It is based on circulating the air under the ground through a duct via a fan or blower.

Besides that, the ground is an energy source; it could also be used for energy storage. There are two types of ground thermal energy storage: borehole [62] and aquifer thermal energy storage [63]. These systems are mainly used to store the excess of energy from RES-based systems to resupply it when required. The advantage of using the ground for thermal energy storage is that it presents a perfect insulated tank using borehole thermal energy storage (BTES) allowing a reduction in the total energy lost. Several studies have been performed to show the importance of this technology using the ground as a seasonal BTES coupled with solar energy-based systems [64, 65]. A heat

transfer fluid is responsible for transferring energy from the solar collector (SC) to the GHE. This can increase the capacity of the ground source and compensate the heat drawn from the ground.

One of the most important GE technologies nowadays is the geothermal power plant (GPP) [66, 67]. This system is mainly based on producing hot geothermal fluid from deep rocks to activate a power cycle and reinject it back to the ground. There are three main types of GPPs: dry-steam [68], flash-steam [69], and binary cycles [70]. The first two cycles directly utilize the geothermal fluid depending on the available conditions such that the former is used when the geothermal fluid is found in the form of steam only. However, the flash cycle uses hot geothermal water and converts it into steam. This could be done with the help of a flash separator that separates the steam and water, allowing the steam to pass through the turbine to generate electricity. Flash cycles are mainly found in the form of single and double flash cycles such that one or two separators are used, respectively. Researchers have recently developed this cycle to operate with more than two separators, known as the multi-flash cycle. This will help to extract the maximum possible amount of power from the geothermal fluid before being reinjected. On the contrary, with steam and flash cycles, the binary GPP does not utilize the geothermal fluid directly. It is mainly based on activating an organic Rankine cycle (ORC) and especially when the geothermal source is considered as a low-grade source [71]. In this case, the geothermal fluid will be responsible for heating the working fluid by passing through a heat exchanger. This makes the choice of working fluid a critical parameter in such GPP's cycles. The two mentioned GPPs are the conventional types; however, several enhancements have been done to these cycles to improve the overall efficiency of the system. Adding internal heat exchangers is one of these techniques which can be considered as a heat recovery subsystem [72]. In GPPs, there are two types of internal heat exchangers' incorporations, namely, recuperator and regenerator. The internal heat exchanger's

role is to allow the exchange of heat between the fluid exiting the turbine/turbine stages and that exiting the pump. Another method of GPP's enhancement is the integration between two cycles forming the flash-binary cycle such that the flash-steam is the topping cycle while the binary is the bottoming cycle [73, 74].

The most critical issues related to shallow GE-based systems are the thermal imbalance and dynamic temperature changes [75]. In many cases, when the load is high compared to the geothermal source's potential, the ground will be unable to recover the energy being extracted. This will lead to an imbalance in the ground that may be found in heat accumulation or thermal depletion, depending on the type of application. Thus, a supplementary source could be used to form a hybrid geothermal system. This is essential to avoid ground fouling or thermal imbalance and to ensure stability in terms of performance. One of the most commonly used geothermal hybrids is the solar-geothermal combination [76, 77]. This form of hybridization has been gaining huge interest from researchers for being RES-based, and since solar energy is a heat source that perfectly fits the heat recovery need of the ground. The integration of another source is also beneficial in low-grade deep GE systems, making the geothermal fluid's temperature suitable for power generation.

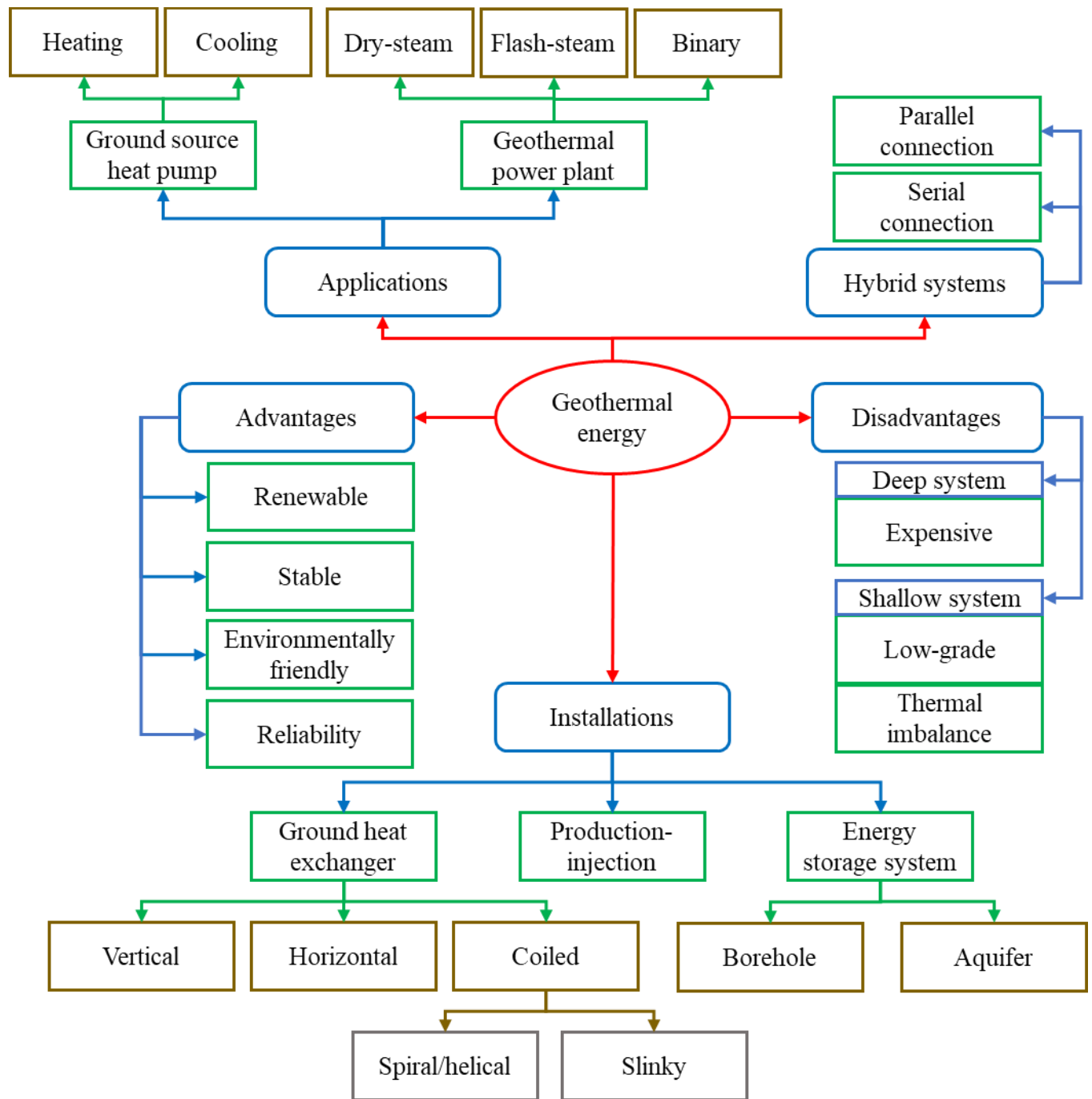

Figure 3: The characteristics of geothermal energy-related systems

4. Hydrogen Production Using Geothermal Energy

Geothermal-driven hydrogen production systems mainly utilize PEM electrolyzers to decompose water into hydrogen and oxygen. Table 1 summarizes the results obtained in the previous investigations reviewed in the current study, including the most important parameters such as hydrogen production, simulation method, exergy efficiency, energy efficiency, and main objectives. The rate of production and efficiencies declared in the table are those corresponding either to the highest values or to the optimal operating conditions based on other factors such as the economic viability. The temperature of water at which the electrolysis is taking place is one of the most important parameters affecting hydrogen production, required power, and operating cost. Yilmaz *et al.* [78] investigated the effect of temperature on the electrolysis process in a geothermal-driven hydrogen production system based on an artificial neural network. It was observed that if temperature increases from 25°C to 70°C the power required for hydrogen production will decrease from 43.51 kW/kg to 42.2 kW/kg, which corresponds to a reduction of approximately 3%. Typically, a preheater is placed to increase the water's temperature entering the electrolyzer [79]. In GPP-hydrogen production systems, the geothermal fluid has two roles: generating electricity via power plant and preheating water. First, the hot geothermal fluid drawn from the production well passes through the GPP and secondly, the residual heat will be used for water preheating. The air preheater is responsible for extracting the heat remaining in the geothermal fluid before it is reinjected back into the ground. In Ref. [80], the geothermal fluid temperature change was also investigated in a combined cooling and power system used for ice-making and hydrogen production. The system was formed of four subsystems, namely, geothermal flash cycle, Kalina cycle (KC), ammonia-water absorption refrigeration cycle, and the electrolyzer. The results showed that when the geothermal fluid temperature is 150°C, 160°C, and 170°C the

exergy efficiency will be 23.59%, 25.06%, and 26.25%, respectively. The geothermal fluid's mass flow rate is also an important factor that greatly influences the system's performance. This is related to the heat transfer rate and grade of GE utilized since it represents the working fluid in case of flash cycle and heat transfer fluid in the binary cycle. This means that the geothermal fluid's flow rate can control the hydrogen production rate. Yilmaz *et al.* [81] studied the importance of this parameter and deduced that a 0.253 g of hydrogen is produced for each kilogram of geothermal water. This was calculated at geothermal resource temperature and flow rate of 160°C and 100 kg/s, respectively, such that the rate of hydrogen production was 0.0253 kg/s. The authors also investigated another study based on a geothermal resource temperature of 200°C with the same flow rate [82]. The proposed system was driven by a flash-binary GPP as shown in Figure 4. The cycle consists of two subsystems: topping and bottoming. The geothermal fluid passes through a flash separator which separates steam and water. The steam is used as a working fluid in the flash cycle such that it enters the steam turbine to generate electricity while the heat carried by the hot water exiting the separator will be extracted via heat exchanger. This heat is transferred to the organic fluid which is responsible for generating additional electricity by means of an ORC turbine. In comparison with the first system studied by the authors, the latter was able to produce more amount of hydrogen such that it was increased to 0.0498 kg/s. However, this was accompanied by an increase in hydrogen production cost from 2.366 \$/kg to 3.14 \$/kg H₂. The cycle's operating conditions are essential parameters that need to be chosen precisely to achieve the optimal operation. Therefore, it is necessary to perform parametric studies to determine the optimal cycle's conditions since they can be controlled more easier than the geothermal fluid's temperature. For example, the turbine inlet pressure and the pinch point temperature are two of the most important parameters affecting the output power and production rates [83]. Thus, producing

hydrogen from geothermal systems is not only dependent on the available geothermal conditions even though the ground is the main energy source. There are other critical components in such hydrogen production systems such as the cooling system which usually corresponds to the highest exergy destruction. Liquefied natural gas (LNG) has been recently considered as an improvement to the cooling system (condenser) which has a good heat sink potential. It also provides additional amount of power since due to the presence of secondary power generator which is the LNG-turbine [84]. With this focus on the exergetic performance and destruction, it is a must to perform thermo-economic optimizations in order to reduce the unit costs of products, which is mainly applied by using the genetic algorithm method [85]. This analysis usually takes into account the effect of all of the system's components on the exergetic performance and product cost. Several parameters are involved in the exergo-economic performance analysis: fuel exergy and cost, product exergy and cost, exergy destruction and cost, exergetic unit cost of electricity, and exergetic cost of hydrogen production.

Table 1: Summary of geothermal-driven hydrogen production systems reviewed in the current study

Reference	Year	Solver/Method	Production	Efficiency	Objective(s)
Cao <i>et al.</i> [86]	2020	EES	11.42 g _H /s & 2050 kW _e	14.8% _{en}	Working fluid selection
Cao <i>et al.</i> [80]	2018	MATLAB	24.82 L _H /s, 7.25 kg _{ice} /s & 414.10 kW _e	20.24% _{ex}	Ice-making & hydrogen production
Ebadollahi <i>et al.</i> [84]	2019	EES	1020 kW _c , 334.8 kW _{heat} , 1060 kW _e & 5.439 kg _H /h	38.33% _{en} & 28.91% _{ex}	Utilizing LNG as a heat sink
Ghaebi <i>et al.</i> [87]	2018	EES	1.197 kg _H /s	3.511% _{en} & 67.58% _{ex}	Working fluid selection based on the total revenue required method
Gholamian <i>et al.</i> [88]	2018	EES	304.2 kg _H /day	55.39% _{ex}	Incorporating TEG and hydrogen production with geothermal-based ORC

Gouareh <i>et al.</i> [89]	2015	GIS	3.4 Mkg _h /year	-	Capturing and sequestration of CO ₂
Han <i>et al.</i> [90]	2020	MATLAB	0.3683 kg _h /hr & 125.71 kW _e	18.9% _{en} & 57.39% _{ex}	Zeotropic mixtures
Karakilcik <i>et al.</i> [91]	2019	EES	21.1 kg _h /h & 3.9 MW _e	6.2% _{en} & 22.4% _{ex}	Investigation of chlor-alkali cell
Karapekmez & Dincer [92]	2018	EES	9.7 g _h /s	27.8% _{en} & 57.1% _{ex}	AMIS unit utilization
Khanmohammadi <i>et al.</i> [93]	2020	EES	37.26 kW _e		Contribution of fuel cell & thermoelectric generator
Kianfard <i>et al.</i> [94]	2018	EES	15.9 kg _h /h & 3804 kW	23.09 % _{ex}	Desalination and hydrogen production
Li <i>et al.</i> [95]	2020	-	1571.1 kW _e	4.94% _{en} & 23.77% _{ex}	Contribution of fuel cell in the ORFC
Ratlamwala & Dincer [96]	2012	EES	-	47.29% _{ex}	Multi-flash GPPs comparison
Seyam <i>et al.</i> [97]	2020	Aspen Plus & EES	335 ton _h /day & 130MW _e	26.74% _{en} & 85.71% _{ex}	Investigation of large-scale liquefaction system
Yilmaz & Kanoglu [79]	2014	-	0.0340 kg _h /s & 3810 kW _e	6.7% _{en} & 23.8% _{ex}	Effect of geothermal and electrolysis temperatures
Yilmaz [85]	2017	Aspen Plus & EES	0.05269 kg _h /s & 7993 kW _e	8.489% _{en} & 38.44% _{ex}	Thermo-economic optimization
Yilmaz [98]	2020	Aspen Plus & EES	0.05 kg _h /s & 7856 kW _e	6.5% _{en} & 32.4% _{ex}	Hydrogen production and liquefaction
Yilmaz <i>et al.</i> [99]	2012	-	0.217 kg _h /s	-	Hydrogen production and liquefaction
Yilmaz <i>et al.</i> [78]	2019	MATLAB & EES	0.05269 kg _h /s & 7978 kW _e	8.47% _{en} & 38.37% _{ex}	Artificial neural network approach
Yilmaz <i>et al.</i> [81]	2015	Aspen Plus & EES	0.0253 kg _h /s	6.7% _{en} & 23.8% _{ex}	Thermodynamic & exergo-economic analyses
Yilmaz <i>et al.</i> [82]	2015	Aspen Plus	0.0498 kg _h /s	8.0% _{en} & 45.8% _{ex}	Thermodynamic & exergo-economic analyses
Yuksel & Ozturk [100]	2017	EES	0.075 kg _h /s & 8.5 MW _e	47.04% _{en} & 32.15% _{ex}	Energy, exergy & thermo-economic analyses
Yuksel <i>et al.</i> [101]	2018	EES	0.0558 kg _h /s & 7937 kW _e	64% _{ex}	Hydrogen production and liquefaction
Yuksel <i>et al.</i> [102]	2018	EES	0.06 kg _h /s	42.59% _{en} & 48.24% _{ex}	Production of power, hydrogen, oxygen, cooling, heat & hot water
Yuksel <i>et al.</i> [83]	2018	EES	0.055 kg _h /s	39.46% _{en} & 44.27% _{ex}	District cooling, domestic hot water & hydrogen production

Cogeneration plants have been frequently investigated in geothermal-driven hydrogen production systems to produce different outputs such as hydrogen and electricity. It has been found that GPPs always generate electricity, but in some cases all electricity is transferred into hydrogen energy. Usually, topping and bottoming cycles are used in cogeneration plants and are mainly based on ORCs such as that studied in Ref. [94]. A dual fluid ORC was used in order to activate a desalination unit and PEM electrolyzer via the topping and bottoming cycles, respectively. The aim of using two fluids is to generate more power and cope with the available conditions in both cycles. This allows to extract the maximum possible energy found in the geothermal fluid and reduce the energy lost. The latter benefit can be achieved by exchanging heat between the two ORCs. The condenser of the topping cycle can be used as a heat source for the bottoming cycle allowing the evaporation and superheating. Yuksel *et al.* [102] proposed a geothermal-based-KC to provide district cooling in addition to hydrogen production. The system was based on utilizing the excess of heat that is found in the geothermal fluid before being reinjected by passing through an absorption cooling system (ACS). The second method to extract the maximum possible amount of heat from the geothermal fluid is to use a multi-flash GPP which will indeed improve the overall energetic and exergetic efficiencies of the system [96]. The multi-flash cycle is mainly based on using a flash separator before each turbine stage to separate water and steam.

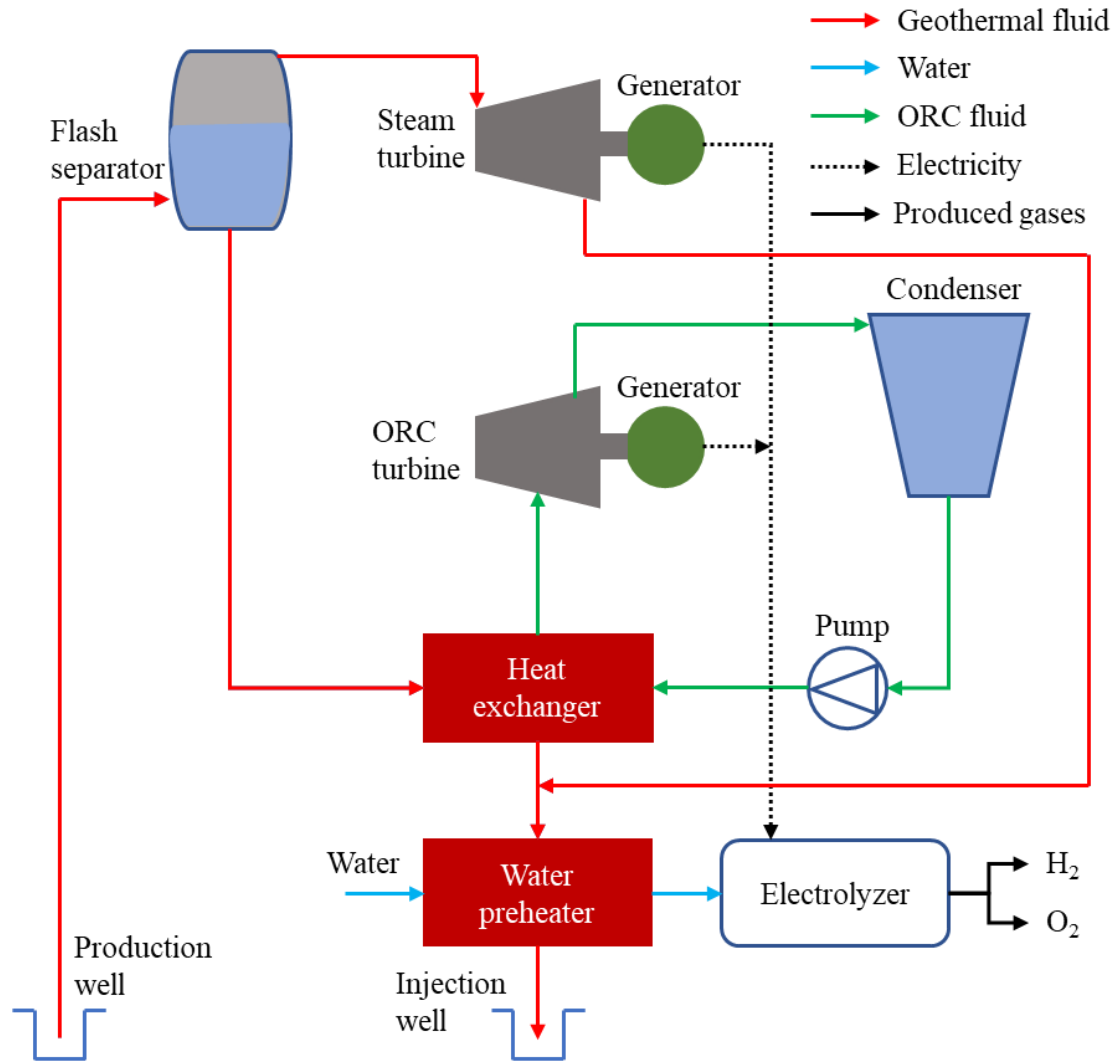

Figure 4: Hydrogen production using flash-binary geothermal power plant

4.1. Working fluids

One of the most important issues related to geothermal-driven systems used for hydrogen production is working fluid selection. Geothermal binary cycles are usually based on ORCs due to the low temperature of the available geothermal fluid in most cases. Organic fluids are able to activate power cycles from low-grade energy sources since they are characterized by suitable operating conditions. ORCs utilize fluids having low boiling point compared to the conventional Rankine cycle. Ghaebi *et al.* [87] integrated a regenerative ORC in a geothermal cogeneration

system to produce hydrogen and electricity. Among the compared working fluids, R245fa was the best choice, such that the energy and exergy efficiencies were 3.511% and 67.58%, respectively. In Ref. [86], a parametric study was carried out to choose the suitable working fluid in hydrogen production systems using GE. The authors deduced that the best working fluid is R123 followed by isopentane such that the former corresponds to hydrogen production of 11.42 g/s while the latter of 11.31 g/s. However, the minimum cost per unit exergy was obtained using isopentane of 36.9 \$/GJ. The production rate and cost are highly affected by the extracted power and the geothermal water temperature. Gholamian *et al.* [88] compared several working fluids to conclude that R114 is the best choice. It was also considered as the most cost-efficient working fluid since it corresponds to the lowest cost per unit exergy and hydrogen production. The system produced 304.2 kg of hydrogen throughout the day, with an exergy efficiency of 55.39%. The proposed system was formed of a geothermal-based ORC, thermoelectric generator, and PEM electrolyzer. This combination contributes to reduce the specific product cost because the hydrogen production rate is usually proportional to the superheated degree at the turbine inlet. Zeotropic mixtures could also be used as working fluids in ORCs to enhance the net output power and hence to increase the amount of hydrogen produced [90]. These mixtures could be formed of several fluids such as Pentane, Butane, Butene, Isopentane, Hexane, Isohexane, and R254fa. Zeotropic mixtures can reduce the irreversibility in the heat exchangers compared to pure fluids, and this depends mainly on the mass fractions. The ratio of fluids used in the mixture can also control the amount of hydrogen produced, exergy extraction, and thermal efficiency [103]. For example, choosing a fluid having low boiling point helps to increase the amount of hydrogen produced and exergy extraction; however, the ORC's thermal efficiency is better for fluids with higher boiling points. The environmental impact is also an important factor that needs to be considered while choosing the

working fluid. Energy-related systems usually emit large amounts of CO₂, which is one of the most dangerous pollutants. Thus, carbon capture and storage (CCS) have been frequently used to mitigate this fluid's environmental impact. Storing CO₂ under the ground could also be helpful in activating GPPs. This could be applied by storing the CO₂ via CCS deep under the ground, which will then be heated and pressurized instead of being released. After that, the CO₂ could be used as a working fluid to produce hydrogen by the help of a GPP which will be connected to the electrolyzer [89]. This makes the integration of CCS and the geothermal-driven hydrogen production system an efficient technique to reduce the effect of CO₂ on the environment.

4.2. Solar-geothermal

Several studies have been performed to increase the temperature of the geothermal fluid before being utilized for hydrogen production and especially when GE is considered as a low-grade heat source. Thus, it is necessary to use another energy source and would be preferable to be a RES such as solar energy keeping the system fully green. The use of a supplementary source provides additional amount of power and can enhance the productivity of the plant by preheating/reheating the geothermal/working fluid. Table 2 presents a summary of all reviewed solar-geothermal systems used to produce hydrogen. The data collection was also based on the same concept presented in Table 1; either the highest hydrogen production rate and efficiency or the values corresponding to the optimal operating conditions. Atiz [104] compared the contribution of three different types of SCs known as parabolic trough solar collector (PTSC), evacuated tube solar collector (ETSC), and flat plate solar collector (FPSC). The highest energetic and exergetic performances were 5.67% and 7.49%, respectively, and obtained when using the PTSC. In addition, the hydrogen produced per day was 2758.69 g, 1585.27 g, and 634.42 g in the case of using PTSC, ETSC, and FPSC, respectively. The incorporation of two energy sources allows the

production of multiple outputs due to the different available sources' characteristics. As an example, solar-geothermal integration could be used as a trigeneration system to generate electricity, produce hydrogen, and provide cooling [105]. Trigeneration is the upgraded form of the cogeneration system such that the former provides three types of outputs, while the latter provides only two types. Poly-generation/MGSs are usually adopted to enhance the overall efficiency of existing power plants [106] and mitigate their environmental impacts [107]. Several types of outputs could be supplied via poly-generation systems such as heating, domestic hot water, cooling, electricity, and hydrogen [100]. Even though the rate of hydrogen production is not significantly enhanced by using solar-geothermal-driven systems, the aim of this hybridization is mainly to adopt MGSs to provide different outputs. This will indirectly reduce the production system's operating cost by taking advantage of the different sources' specifications and related systems. For example, the excess power of the geothermal-based-ORC could be used for activating a heat pump's compressor in which the solar photovoltaic (PV) subsystem is responsible for adding heat to the evaporator [108]. Kursun [109] investigated the contribution of a concentrated PV recuperator in a geothermal-based MGS used to provide heating, cooling, power and hydrogen. This integration enhanced the overall energetic efficiency while decreasing the exergetic efficiency due to the high solar inputs. The achieved enhancements were in the ranges of 1.3-42%, 0-17.6%, 8.1-13.5%, and 1.34-44.2% for hydrogen production, cooling capacity, heating capacity, and net power output. In Ref. [110], a comparison between two types of solar-geothermal combinations was examined, namely, Rankine-Trough-Vapor (RTV) and Vapor-Trough-Rankine (VTR). The two configurations are formed of SCs, geothermal resource, vapor absorption cycle (VAC), Rankine cycle (RC), and the electrolyzer. In the RTV cycle, the geothermal production well is directly connected to the RC to produce power and hydrogen. Then, the SCs is responsible for

heating the geothermal fluid again before passing through the VAC generator. However, the RC and VAC are replaced with each other in the case of VTR cycle. The overall exergy efficiency varied between 56.19% and 61.59% for the RTV while that of the VTR was higher, varying between 63.46% and 70.16%. On the other hand, the former yields more hydrogen such that it was increased from 0.2382 g/s to 0.3252 g/s while that of the latter was from 0.2072 g/s to 0.2939 g/s when changing the same parameters in both cycles. Siddiqui and Dincer [111] proposed a hybrid MGS known as solar integrated ammonia fuel cell and geothermal based energy system. It is formed of 6 subsystems: geothermal flash, ORC, solar-based ammonia fuel cell, electrolysis, reverse osmosis (RO) desalination, and ACS. The system produces four different outputs that are electricity, freshwater, hydrogen, and cooling, with overall energetic and exergetic efficiencies of 42.3% and 21.3%, respectively. In the proposed system, GE was responsible for activating the flash cycle and ACS while the heat added to the ORC was provided by both sources, geothermal and solar energies. However, the ammonia fuel cell and the RO desalination unit were activated via solar energy only.

Table 2: Summary of hydrogen production driven by solar-geothermal systems reviewed in the current study

Reference	Year	Solver/Method	Production	Efficiency	Objective(s)
Al-Nimr <i>et al.</i> [112]	2017	Microsoft Excel & EES	103 kW _e	21.95% _{en}	Incorporating solar-geothermal plant with fuel cell
Atiz [104]	2020	EES	2758.69 g _h /day & 414.93 MJ _e /day	5.67% _{en} & 7.49% _{ex}	Comparing the contributions of different SCs
Bicer & Dincer [108]	2016	EES	18.23 kg _h /h	10.8% _{en} & 46.3% _{ex}	Providing cooling, heating, power & hydrogen
Karapekmez & Dincer [113]	2020	EES	156 g _h /s	78.37% _{en} & 58.40% _{ex}	Multigeneration system development
Kursun [109]	2020	EES	-	27.22% _{ex}	Adding a concentrated PV recuperator

Siddiqui & Dincer [111]	2020	EES	0.49 mol _h /s, 4631 kW _e & 1488 kW _c	42.3% _{en} & 21.3% _{ex}	Production of electricity, fresh water, hydrogen, & cooling
Siddiqui <i>et al.</i> [105]	2019	Aspen Plus & EES	32.1 mol _h /s, 3398 kW _e & 603.9 kW _c	19.6% _{en} & 19.1% _{ex}	Development of a trigeneration system
Temiz & Dincer [106]	2020	HOMER & EES	7938 kg _h /year, 1642 MWh _e /year & 485 MWh _{th} /year	16.3% _{en} & 14.9% _{ex}	Production of electricity, district heating, desalination & hydrogen
Waseem <i>et al.</i> [110]	2020	EES	0.296 g _h /s	70.16% _{ex}	Comparison between RTV & VTR

4.3. AMIS unit

In GPPs, the extracted geothermal fluid is usually formed of steam and non-condensable gases (NCG). These gases are harmful to the environment when released, such as hydrogen sulfide (H₂S) which is emitted in large amounts in GPPs. Thus, modern technologies have been focused on managing treatments for the NCG, such as the AMIS unit (AMIS® - acronym for “abatement of mercury and hydrogen sulfide” in Italian language) which is displayed in Figure 5. This unit mainly contributes to mitigate the effects of mercury and hydrogen sulfide. However, modern types of AMIS have been updated to produce hydrogen by sending the hydrogen sulfide to an electrolyzer. The AMIS unit captures the NCG and separates them to be treated with the help of other mechanisms (ex: hydrogen sulfide electrolyzer). Such techniques are able to enhance geothermal-driven hydrogen production systems in terms of environment and economic viability due to the reduction in pollution and increase in productivity. The hydrogen sulfide electrolyzer is responsible for decomposing hydrogen and sulfur, which is activated via electric power similarly as that of the water PEM electrolyzer [113]. The electrical power required for activating the hydrogen sulfide electrolyzer depends mainly on the inlet temperature. As calculated in Ref. [92], the required electric power declines from 73.7 kW to 58 kW if the hydrogen sulfide temperature rises from 300 K to 800 K. The corresponding exergy efficiency was also increased due to the

change in temperature from 54.4% to 68.9%. Another important parameter in the AMIS unit is the mass flow rate of hydrogen sulfide that has presented an inversely proportional relation with respect to the required input power. The authors achieved a hydrogen production of 9.7 g/s that was obtained at superheated steam and H₂S mass flow rates of 1500 kg/s and 165 g/s, respectively.

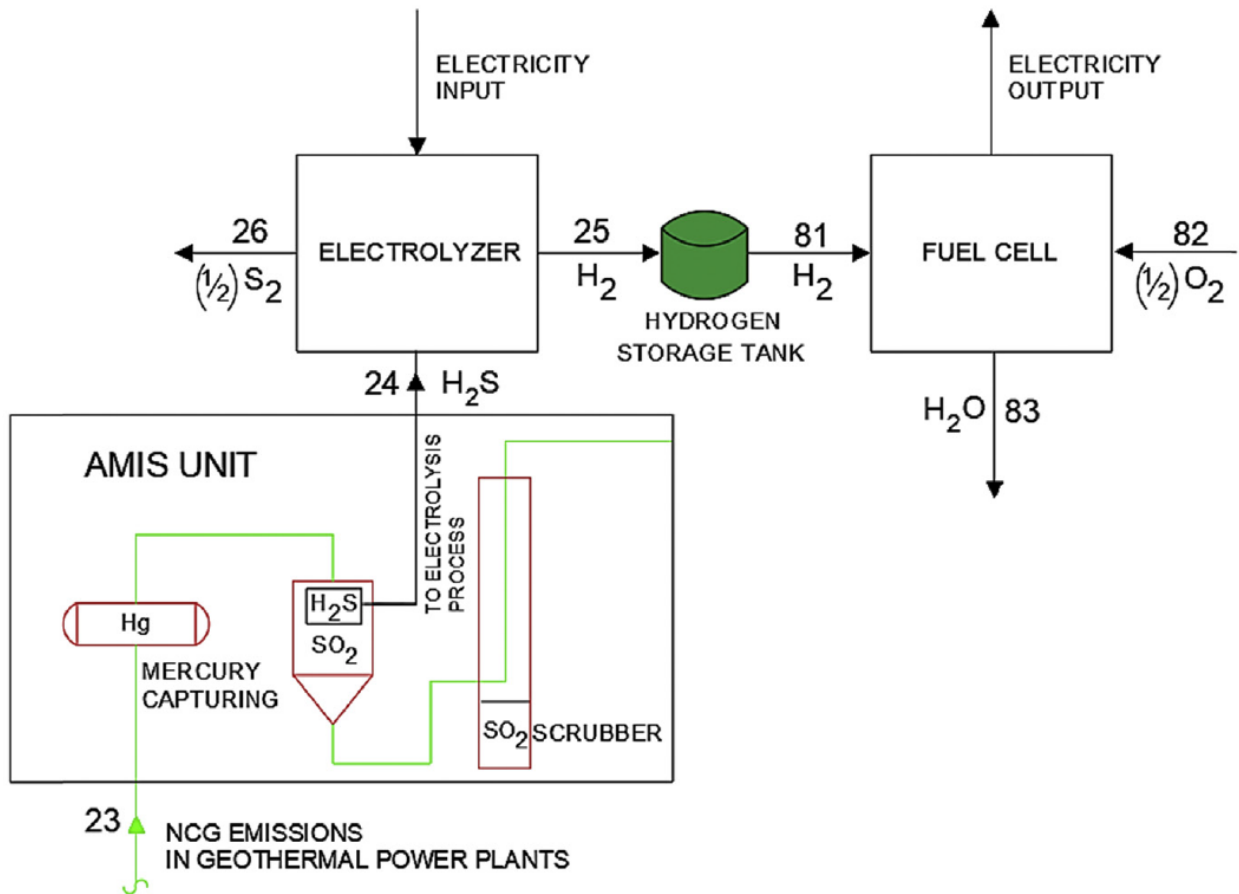

Figure 5: AMIS technology used for hydrogen production [113]

4.4. Chlor-alkali cell

As presented in the previous sections, producing different types of outputs is a key factor used to enhance the system's overall efficiency. Conventional electrolyzers usually produce only one type of output, such as the PEM, which produces hydrogen only. However, in the case of using a chlor-alkali cell, two more substances could be produced in addition to the hydrogen, namely,

chlorine and sodium hydroxide as shown in Figure 6. Karakilcik *et al.* [91] investigated a chlor-alkali cell based on a geothermal powered system to produce hydrogen. The authors deduced that if the geothermal fluid temperature rises from 140°C to 155°C, the amount of hydrogen produced and electricity generated will increase from 10.5 kg/h to 21.1 kg/h and 2.5 MW to 3.9 MW, respectively. The corresponding energetic and exergetic efficiencies were also calculated as 6.2% and 22.4%.

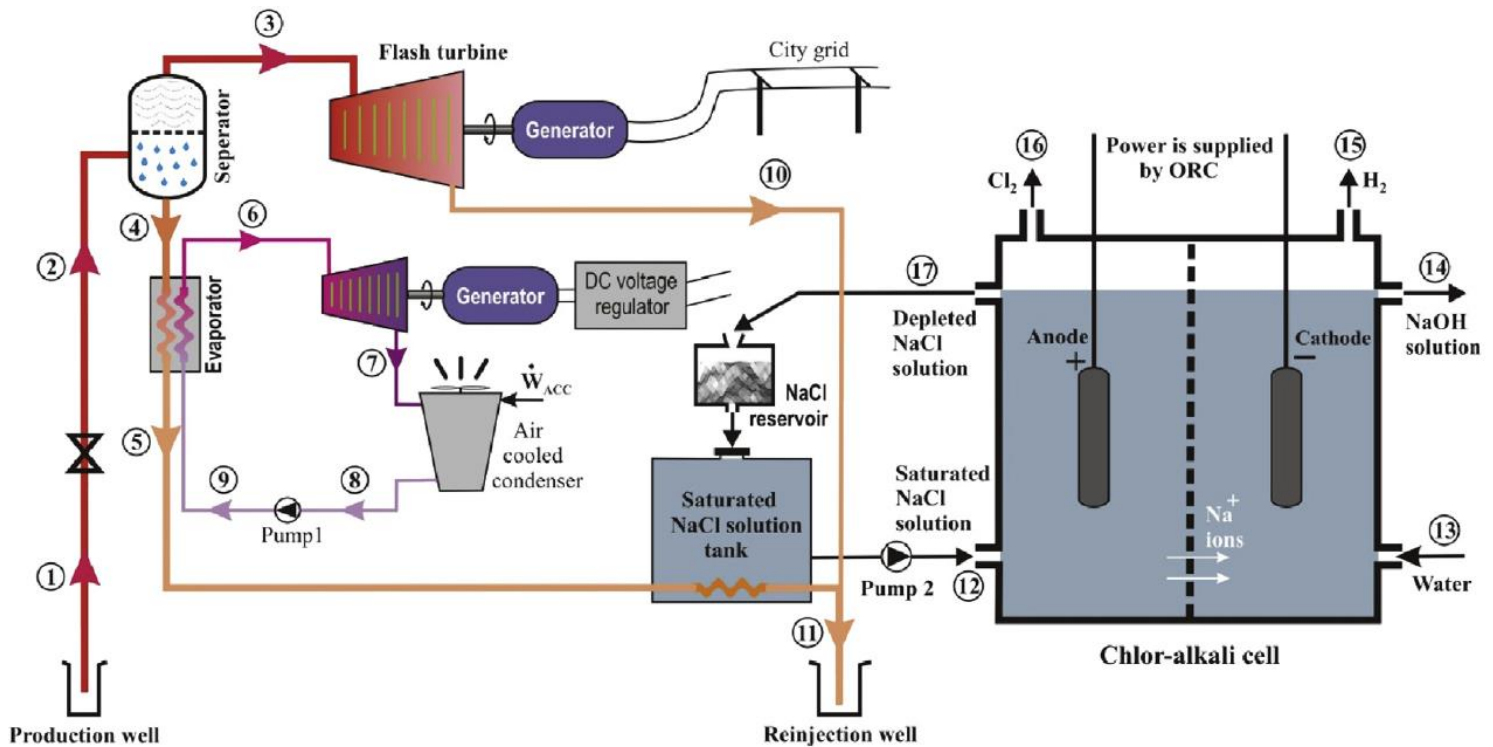

Figure 6: Chlor-alkali cell integrated into a geothermal power plant [91]

4.5. Hydrogen liquefaction

Hydrogen produced from electrolysis is in the form of gas, which makes its storage a critical issue. Thus, it is highly recommended to transform it into liquid hydrogen by passing through a process known as liquefaction [97]. Even though this process may consume more power, liquid hydrogen indeed requires a smaller volume of storage than that of gas. This will make its storage and

transportation easier considering it as an energy source or carrier. It is recommended that hydrogen is transformed into a liquid immediately in the same site and by the same resource, which is GE in this case. This treatment is especially beneficial in remote areas that are based on the ground as a power source due to transportation purposes [98]. Yuksel *et al.* [101] studied a hydrogen production and liquefaction system based on geothermal energy-based power cycle to ascertain the effect of related parameters on the system's performance (see Figure 7). The parametric study showed that if the geothermal fluid temperature increases from 130°C to 200°C, the hydrogen produced rate will increase from 0.0062 kg/s to 0.0558 kg/s. Another important parameter was detected, which is the ambient temperature such that if it was changed from 0°C to 40°C the exergetic efficiency will be improved from 44% to 52%. Usually, GE is used to provide electric power to the hydrogen production and liquefaction systems, which is the conventional method. However, it could also be used in activating the absorption refrigeration cycle to precool the gas before its liquefaction [99].

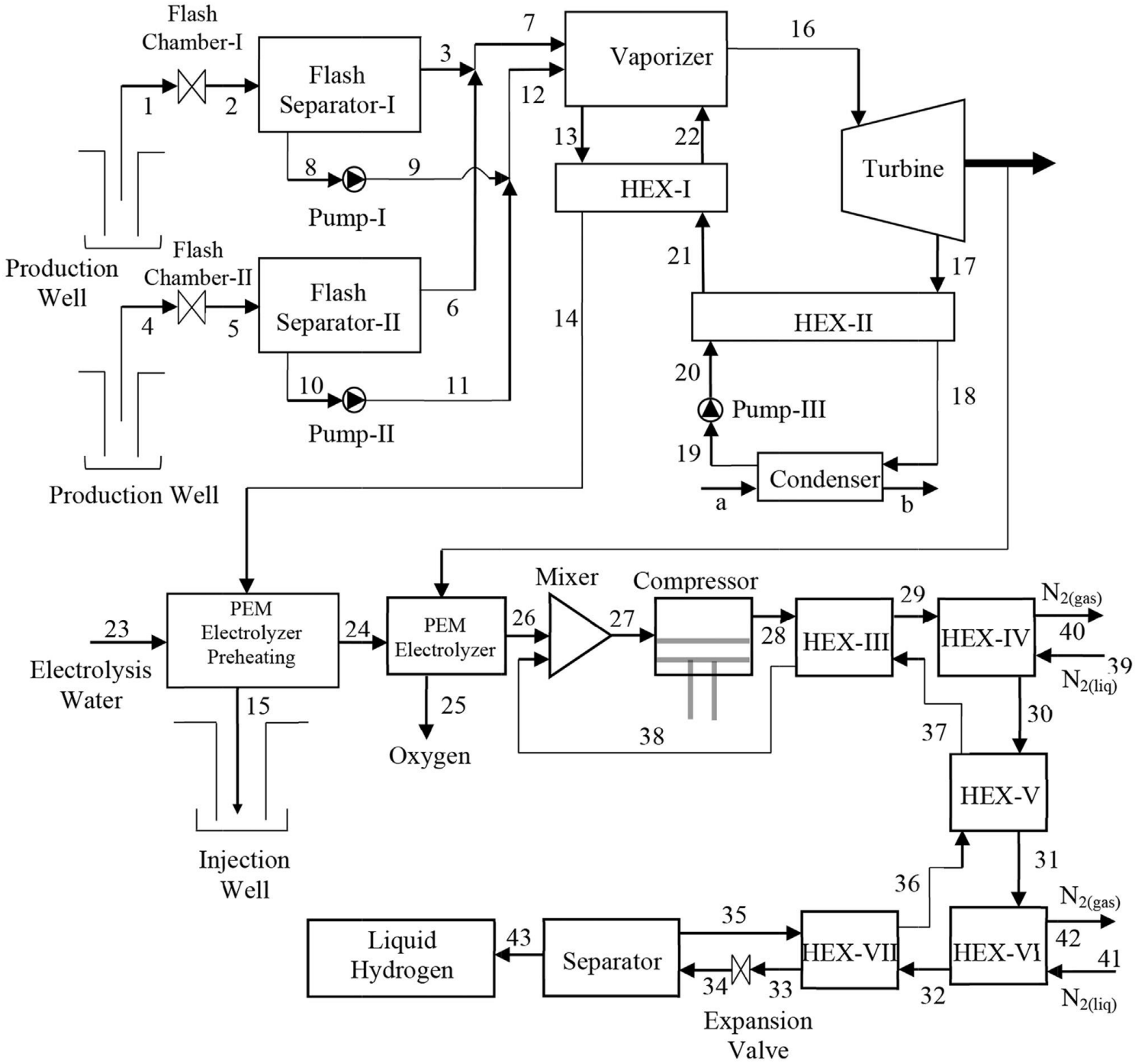

Figure 7: Geothermal-driven hydrogen production and liquefaction system [101]

4.6. Fuel cell-based systems

A fuel cell is a green storage device that stores hydrogen to be used later when needed for providing electricity [114, 115]. Figure 8 illustrates the principle of hydrogen fuel cell presenting all its

components. This technology has been passing through significant development recently since it can be used in a wide variety of applications. In the previous sections, GE was used to drive hydrogen production systems. However, some applications utilize fuel cells to provide an additional amount of power to the GPP during peak demands [93]. In such cases, hydrogen is produced only for supporting the primary objective which is power generation. This could be done by placing a fuel cell after the flash separator in case of using a geothermal flash-steam cycle. The liquid exiting the separator could be heated via a fuel cell to produce more power by passing through a second stage turbine. This is considered as an enhancement to the geothermal-based organic Rankine flash cycle (ORFC). Li *et al.* [95] compared the usage of low-temperature geothermal source and PEM fuel cells in the heat addition process after the flash separator in the ORFC. The results showed that the fuel cell could increase the net output power and exergy efficiency. The corresponding enhancements were from 254.9 kW to 1628.9 kW and from 23.77% to 36.19%. The fuel cell could also be used as a storage and feeding unit, especially when the power plant is based only on renewable energies. This is usually found in solar-geothermal systems such that the fuel cell can store the excess of solar energy during the day and supplies it at night or when needed [112]. This can also solve the problem of the stochastic and intermittent nature of RESs and provide an extra amount of power at peak loads.

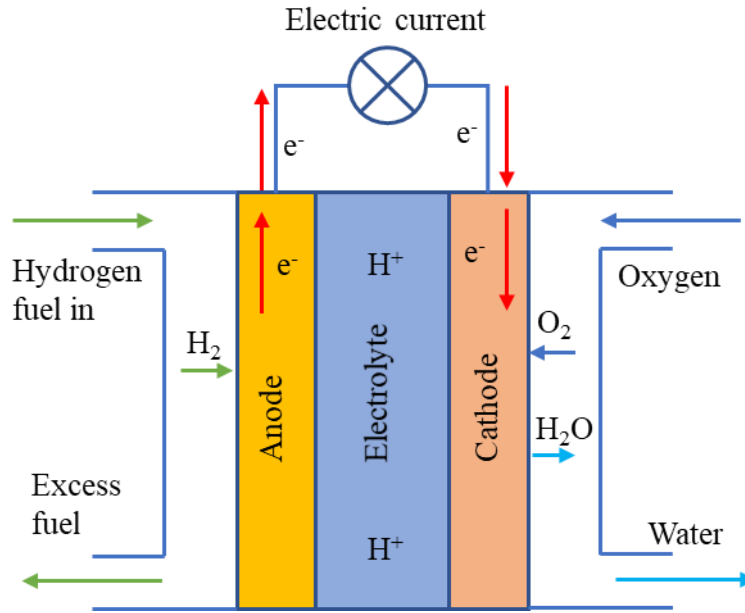

Figure 8: The principle of hydrogen fuel cell

5. Discussion

The literature review presented in the current study has shown a great potential for GE to produce hydrogen via GPPs. This domain is passing through significant development and growth currently as evidenced from the increasing number of related research studies. In the previously reviewed investigations, as shown in Table 1 and Table 2, Engineering Equation Solver (EES) has been very numerical simulation software of choice, that being due to the various built-in properties such as thermodynamics, fluid mechanics, and heat transfer. The integration of hydrogen production into geothermal systems can offer several benefits and mainly making GE portable energy. This could also be addressed using other types of ESSs; however, hydrogen is considered one of the greenest energy carriers. Producing hydrogen using GE is mainly based on water electrolysis, an electrochemical process that requires electricity. The efficiency of geothermal-driven hydrogen production systems is affected by several parameters such as electrolysis temperature [78], geothermal fluid temperature [80], and working fluid [86, 87]. It has been noticed that the rate of

hydrogen production is proportional to both geothermal and water electrolysis temperatures. This imposes placing a water preheater before the electrolyzer which is a typical integration used in most hydrogen production systems [79].

5.1. Economical assessment

GE has presented several advantages compared to other energy sources regarding the environment, stability, and reliability. The major barrier of this source is the capital cost of installation. To make GE-related systems attractive, endeavors are always undertaken to increase the system's performance to increase revenue without unduly increasing the operating cost. This will decrease the payback period and hence encourages the adoption of such systems. Table 3 shows an economic assessment of the reviewed previous investigations and this highlights the fact that the cost is directly affected by the systems used and different combinations. These results are mainly based on the minimum operating cost of the mentioned systems in the corresponding references. It can also be observed that the unit of cost is not always the same and that is due to the type of cost analysis method investigated such that it can be found in the form of exergy, energy or hydrogen production cost.

Table 3: Summary of the operating cost of pervious investigations on geothermal-driven hydrogen production systems

Reference	Year	Cost	System(s)
Cao <i>et al.</i> [86]	2020	36.9 \$/GJ _{ex}	Two-stage ORC
Cao <i>et al.</i> [80]	2018	1.33 \$/GJ _{ex}	Flash cycle, KC & AC
Ebadollahi <i>et al.</i> [84]	2019	409.4 \$/GJ _h	ORC, ejector refrigeration & LNG power generation
Ghaebi <i>et al.</i> [87]	2018	4.921 \$/GJ _h	Regenerative ORC
Gholamian <i>et al.</i> [88]	2018	21.96 \$/GJ _{en}	ORC & thermoelectric generator
Kianfard <i>et al.</i> [94]	2018	4.257 \$/kg _h	Dual-fluid ORC & RO desalination unit
Yilmaz [85]	2017	1.088 \$/kg _h	Flash-binary geothermal based-ORC
Yilmaz <i>et al.</i> [81]	2015	2.366 \$/kg _h	Geothermal binary ORC
Yilmaz <i>et al.</i> [78]	2019	1.088 \$/kg _h	Flash-binary geothermal based-ORC
Yilmaz <i>et al.</i> [82]	2015	3.14 \$/kg _h	Flash-binary geothermal based-ORC

Yuksel & Ozturk [100]	2017	1.1 \$/kg _h	ORC & quadruple effect ACS
Gouareh <i>et al.</i> [89]	2015	4.7 \$/kg _h	CO ₂ -based cycle
Yilmaz <i>et al.</i> [99]	2012	0.979 \$/kg _h	Binary, liquefaction & AC
Yilmaz [98]	2020	2.154 \$/kg _h	Flash-binary & Claude liquefaction
Temiz & Dincer [106]	2020	0.058\$/kWh _{en}	PV, double-flash, refrigeration & distillation-desalination
Li <i>et al.</i> [95]	2020	10.51 \$/h	ORFC & fuel cell

5.2. Environmental impact

Environmentalists have investigated the different parameters affecting the environmental impact of hydrogen production systems according to their sources. Solar energy has been considered as the highest environmental performance source [29]. However, it cannot be simply compared between the different hydrogen production sources because there are numerous variables involved in which their effects can change from one case to another [30, 31]. GE-driven hydrogen production systems have shown a moderate environmental performance compared to other sources and that is mainly due to the water discharge quality, land use, NCG and CO₂. Thus, several technologies have been introduced to reduce the environmental effect of such systems. One of these technologies is the AMIS unit that can be used to decrease the impact of hydrogen sulfide which exists usually in the geothermal fluid. AMIS is responsible for separating the NCG and sending them to specific electrolyzers for extracting additional amount of output and mitigate their negative effects. Another technology is the CCS which has been integrated into various applications to reduce the effect of CO₂ emissions. It was also found that the stored CO₂ can be then used as a working fluid in hydrogen production systems [89]. Additionally, MGSs contribute to lower the effect of wasted gases because the variety of outputs helps to extract the maximum amount of energy from the geothermal fluid [108]. Consequently, the temperature of the flue gases will decrease and their effects will be minimized.

5.3. Results summary

As presented in the reviewed literature, there is a considerable difference between the hydrogen production systems in terms of efficiency, cost, and production. Table 4 presents a summary of the previous research investigations such that the maximum and minimum values of the studied parameters are reported. This table also compares the geothermal and solar-geothermal hydrogen production systems. However, these results cannot be used to directly compare the impact of energy source on the system due to the significant difference between the scale of systems investigated. Also, some of these systems are MGSs, which means that additional outputs are obtained. For example, the highest rate of hydrogen production refers to a geothermal-driven system, which is 13958 kg/h [97] while that of solar-geothermal is 561.6 kg/h [113]. This is due to the latter being used to supply outputs different to hydrogen. Another important parameter that needs to be taken into consideration is the operational mode. This also makes the results incomparable, which requires further investigation. This is due to that in some studies, the off periods are not considered, which may affect the cost and production, especially when based on an annual basis.

Table 4: Summary of the parameters involved in the current study based on the reviewed investigations

Parameter	System	
	Geothermal	Solar-geothermal
Energetic efficiency (%)	3.511-47.04	5.67-78.37
Exergetic efficiency (%)	20.24-85.71	7.49-70.16
Hydrogen production cost (\$/kg)	0.979-4.7	-
Cost per unit of energy (\$/GJ)	21.96	0.058
Cost per unit exergy (\$/GJ)	1.33-36.9	-
Hydrogen production (kg/h)	5.439-13958	0.115-561.6
Electricity generated (MW)	0.037-130	0.005-4.631

5.4. Recommendations

The stability of the ground is one of the most important advantages of GE compared to other RESs, which makes it a non-stochastic energy source. However, GE is considered a low-grade source in many cases, which may make it unreliable at high loads. This may lead to thermal imbalance, heat accumulation, or thermal depletion in shallow GE applications. Additionally, when the geothermal fluid's temperature is low in deep GE systems, this may require the incorporation of another source of energy to increase the fluid's temperature before entering the power cycle. Thus, it would be advisable to use hybrid geothermal systems such as solar-geothermal combination, which is the most commonly known hybridization. The integration of hydrogen production and storage into solar-geothermal power plants is a key element for enhancing the system's overall efficiency. This is because hydrogen can provide additional power when needed at peak-time loads and in the absence of sunlight at night. Therefore, it is highly preferable to adopt MGSs in order to improve the existing plants and to extract the maximum possible amount of power from the available resources [106]. This is explained for the reason that diversification of outputs requires the adoption of recovery systems. MGSs could supply several types of outputs, such as cooling, heating, domestic hot water, hydrogen production, and power. It would also be favorable to use modern GPPs such as the regenerative, recuperative, flash-binary, dual-fluid, ORFC, and multi-flash. These cycles are also based on heat recovery systems using topping and bottoming cycles or internal heat exchangers.

6. Conclusion

This paper has presented the importance of integrating hydrogen production into GE related systems. It has been deduced that GPPs offer various advantages compared to other technologies used to produce hydrogen for being an environmentally friendly, stable, and renewable source.

The most important part of this combination is the coupling between green energy sources and carriers that are GE and hydrogen. The reason for producing hydrogen is not only for direct uses but it could also supply an additional amount of power to the hybrid geothermal system, especially when GE is coupled to another RES. Geothermal hybrids have shown great potential in improving geothermal systems when GE is considered as a low-grade heat source. Hybridization can solve the problem of shallow GE system's thermal imbalance that may occur at high loads, mainly if the ground is standing alone. It also makes a contribution by enhancing the efficiency of deep geothermal systems especially when the geothermal fluid's temperature is low.

The reviewed research studies have shown a huge difference between the parameters related to hydrogen production systems. That is due to the variation in the investigated conditions such as geothermal fluid temperature, electrolysis temperature, working fluid, and type of GPP. The most commonly used GPPs used and coupled with electrolyzers are the flash-steam and binary cycles. However, these cycles have passed through several enhancements, such as using internal heat exchangers or combining the flash and binary cycles. In all types of combinations, the geothermal fluid and water electrolysis temperatures have shown a great influence on the overall system's efficiency. According to the previously reviewed investigations, R245fa, R123, and R114 have been selected as the best working fluids in the binary geothermal ORCs used for hydrogen production.

The current study reviewed different geothermal-driven hydrogen production systems in terms of hydrogen production rate, hydrogen production cost, exergetic efficiency, energetic efficiency, generated electricity, and exergetic cost. The corresponding values were varying from 5.439 kg/h to 13958 kg/h, 0.979 \$/kg to 4.7 \$/kg, 20.24% to 85.71%, 3.511% to 47.04%, 0.037 MW to 130 MW and 1.33 GJ to 36.9 \$/GJ. One of the most important factors influencing these parameters

is the production of different types of outputs which could be addressed by adopting MGSs. These systems can produce heating, cooling, domestic hot water, and electricity in addition to hydrogen which is the main product. Even though MGSs do not always increase the rate of hydrogen production; however, producing various types of outputs will enhance the system's efficiency and hence reduce the production cost. Adopting such systems requires the integration of energy sources forming hybrid energy systems. The solar-geothermal combination was the most common type of hybridization used to produce hydrogen. The reviewed solar-geothermal systems were able to produce volume ranges of hydrogen between 0.115 kg/h to 561.6 kg/h and 0.005 MW to 4.631 MW of electricity with energetic and exergetic efficiencies varying from 5.67% to 78.37% and 7.49% to 70.16%, respectively.

Finally, it can be seen that hydrogen production using GE is worth investigating and is a promising technology for the future. This domain can still pass through immense developments and enhancements by applying comparative and optimization studies to find the best suitable design. It would also be advisable to adopt new hybrid systems different from conventional types, such as the presented solar-geothermal systems.

References

- [1] Masoumeh Ahrabi, Mehrdad Abedi, Hamed Nafisi, Mohammad Amin Mirzaei, Behnam Mohammadi-Ivatloo, Mousa Marzband, Evaluating the effect of electric vehicle parking lots in transmission-constrained AC unit commitment under a hybrid IGDT-stochastic approach, *International Journal of Electrical Power & Energy Systems*, Volume 125, 2021, 106546, ISSN 0142-0615, <https://doi.org/10.1016/j.ijepes.2020.106546>.
- [2] Fengqi Zhang, Xiaosong Hu, Reza Langari, Lihua Wang, Yahui Cui, Hui Pang, Adaptive energy management in automated hybrid electric vehicles with flexible torque request, *Energy*, Volume 214, 2021, 118873, ISSN 0360-5442, <https://doi.org/10.1016/j.energy.2020.118873>.

- [3] Antonio Rosato, Antonio Ciervo, Giovanni Ciampi, Michelangelo Scorpio, Francesco Guarino, Sergio Sibilio, Energy, environmental and economic dynamic assessment of a solar hybrid heating network operating with a seasonal thermal energy storage serving an Italian small-scale residential district: Influence of solar and back-up technologies, *Thermal Science and Engineering Progress*, Volume 19, 2020, 100591, ISSN 2451-9049, <https://doi.org/10.1016/j.tsep.2020.100591>.
- [4] Omar Ramadan, Siddig Omer, Yate Ding, Hasila Jarimi, Xiangjie Chen, Saffa Riffat, Economic evaluation of installation of standalone wind farm and wind + CAES system for the new regulating tariffs for renewables in Egypt, *Thermal Science and Engineering Progress*, Volume 7, 2018, Pages 311-325, ISSN 2451-9049, <https://doi.org/10.1016/j.tsep.2018.06.005>.
- [5] A.M. Mayeda, A.D. Boyd, Factors influencing public perceptions of hydropower projects: A systematic literature review, *Renewable and Sustainable Energy Reviews*, Volume 121, 2020, 109713, ISSN 1364-0321, <https://doi.org/10.1016/j.rser.2020.109713>.
- [6] M. Barbato, L. Cirillo, L. Menditto, R. Moretti, S. Nardini, Feasibility study of a geothermal energy system for indoor swimming pool in Campi Flegrei area, *Thermal Science and Engineering Progress*, Volume 6, 2018, Pages 421-425, ISSN 2451-9049, <https://doi.org/10.1016/j.tsep.2018.02.013>.
- [7] A. Zakaria, Firas B. Ismail, M.S. Hossain Lipu, M.A. Hannan, Uncertainty models for stochastic optimization in renewable energy applications, *Renewable Energy*, Volume 145, 2020, Pages 1543-1571, ISSN 0960-1481, <https://doi.org/10.1016/j.renene.2019.07.081>.
- [8] Gilles Notton, Marie-Laure Nivet, Cyril Voyant, Christophe Paoli, Christophe Darras, Fabrice Motte, Alexis Fouilloy, Intermittent and stochastic character of renewable energy sources: Consequences, cost of intermittence and benefit of forecasting, *Renewable and Sustainable Energy Reviews*, Volume 87, 2018, Pages 96-105, ISSN 1364-0321, <https://doi.org/10.1016/j.rser.2018.02.007>.
- [9] Dimitrios-Sotirios Kourkoumpas, Georgios Benekos, Nikolaos Nikolopoulos, Sotirios Karellas, Panagiotis Grammelis, Emmanouel Kakaras, A review of key environmental and energy performance indicators for the case of renewable energy systems when integrated with storage solutions, *Applied Energy*, Volume 231, 2018, Pages 380-398, ISSN 0306-2619, <https://doi.org/10.1016/j.apenergy.2018.09.043>.
- [10] Hussam Jouhara, Navid Khordehghah, Nicolas Serey, Sulaiman Almahmoud, Stephen P. Lester, Daniel Machen, Luiz Wrobel, Applications and thermal management of rechargeable batteries for industrial applications, *Energy*, Volume 170, 2019, Pages 849-861, ISSN 0360-5442, <https://doi.org/10.1016/j.energy.2018.12.218>.
- [11] Hussam Jouhara, Nicolas Serey, Navid Khordehghah, Robert Bennett, Sulaiman Almahmoud, Stephen P. Lester, Investigation, development and experimental analyses of a heat pipe based battery thermal management system, *International Journal of*

- Thermofluids, Volumes 1–2, 2020, 100004, ISSN 2666-2027, <https://doi.org/10.1016/j.ijft.2019.100004>.
- [12] Bakartxo Egilegor, Hussam Jouhara, Josu Zuazua, Fouad Al-Mansour, Kristijan Plesnik, Luca Montorsi, Luca Manzini, ETEKINA: Analysis of the potential for waste heat recovery in three sectors: Aluminium low pressure die casting, steel sector and ceramic tiles manufacturing sector, *International Journal of Thermofluids*, Volumes 1–2, 2020, 100002, ISSN 2666-2027, <https://doi.org/10.1016/j.ijft.2019.100002>.
- [13] Hussam Jouhara, Alina Żabnieńska-Góra, Navid Khordehgah, Darem Ahmad, Tom Lipinski, Latent thermal energy storage technologies and applications: A review, *International Journal of Thermofluids*, Volumes 5–6, 2020, 100039, ISSN 2666-2027, <https://doi.org/10.1016/j.ijft.2020.100039>.
- [14] Aaron Rimpel, Klaus Krueger, Zhiyang Wang, Xiaojun Li, Alan Palazzolo, Jamshid Kavosi, Mohamad Naraghi, Terry Creasy, Bahar Anvari, Eric Severson, Eugene Broerman, Chapter 4 - Mechanical energy storage, *Thermal, Mechanical, and Hybrid Chemical Energy Storage Systems*, Academic Press, 2021, Pages 139-247, ISBN 9780128198926, <https://doi.org/10.1016/B978-0-12-819892-6.00004-6>.
- [15] Mohd Alam, Kuldeep Kumar, Viresh Dutta, Dynamic modeling and experimental analysis of waste heat recovery from the proton exchange membrane fuel cell using thermoelectric generator, *Thermal Science and Engineering Progress*, Volume 19, 2020, 100627, ISSN 2451-9049, <https://doi.org/10.1016/j.tsep.2020.100627>.
- [16] Rolandas Jonynas, Egidijus Puida, Robertas Poškas, Linas Paukštaitis, Hussam Jouhara, Juozas Gudzinskas, Gintautas Miliauskas, Valdas Lukoševičius, Renewables for district heating: The case of Lithuania, *Energy*, Volume 211, 2020, 119064, ISSN 0360-5442, <https://doi.org/10.1016/j.energy.2020.119064>.
- [17] Gaétan Chardon, Nolwenn Le Pierrès, Julien Ramousse, On the opportunity to integrate absorption heat pumps in substations of district energy networks, *Thermal Science and Engineering Progress*, Volume 20, 2020, 100666, ISSN 2451-9049, <https://doi.org/10.1016/j.tsep.2020.100666>.
- [18] Paulo Gambôa, J. Fernando Silva, S. Ferreira Pinto, Elmano Margato, Input–Output Linearization and PI controllers for AC–AC matrix converter based Dynamic Voltage Restorers with Flywheel Energy Storage: a comparison, *Electric Power Systems Research*, Volume 169, 2019, Pages 214-228, ISSN 0378-7796, <https://doi.org/10.1016/j.epsr.2018.12.023>.
- [19] Shaoquan Lin, Tao Ma, Muhammad Shahzad Javed, Prefeasibility study of a distributed photovoltaic system with pumped hydro storage for residential buildings, *Energy Conversion and Management*, Volume 222, 2020, 113199, ISSN 0196-8904, <https://doi.org/10.1016/j.enconman.2020.113199>.
- [20] Jie Song, Xiaodong Peng, Xiangjun Fang, Ying Han, Zhanfeng Deng, Guizhi Xu, Lixiao Liang, Jibiao Hou, Hongwei Wu, Thermodynamic analysis and algorithm optimisation of

a multi-stage compression adiabatic compressed air energy storage system, *Thermal Science and Engineering Progress*, Volume 19, 2020, 100598, ISSN 2451-9049, <https://doi.org/10.1016/j.tsep.2020.100598>.

- [21] Ahmad Haddad, Mohamad Ramadan, Mahmoud Khaled, Haitham S. Ramadan, Mohamed Becherif, Triple hybrid system coupling fuel cell with wind turbine and thermal solar system, *International Journal of Hydrogen Energy*, Volume 45, Issue 20, 2020, Pages 11484-11491, ISSN 0360-3199, <https://doi.org/10.1016/j.ijhydene.2019.05.143>.
- [22] Vikrant Venkataraman, Ahmad El-Kharouf, Bhargav Pandya, Eridei Amakiri, Robert Steinberger-Wilckens, Coupling of engine exhaust and fuel cell exhaust with vapour absorption refrigeration/air conditioning systems for transport applications: A review, *Thermal Science and Engineering Progress*, Volume 18, 2020, 100550, ISSN 2451-9049, <https://doi.org/10.1016/j.tsep.2020.100550>.
- [23] Petronilla Fragiaco, Matteo Genovese, Technical-economic analysis of a hydrogen production facility for power-to-gas and hydrogen mobility under different renewable sources in Southern Italy, *Energy Conversion and Management*, Volume 223, 2020, 113332, ISSN 0196-8904, <https://doi.org/10.1016/j.enconman.2020.113332>.
- [24] Barbara Widera, Renewable hydrogen implementations for combined energy storage, transportation and stationary applications, *Thermal Science and Engineering Progress*, Volume 16, 2020, 100460, ISSN 2451-9049, <https://doi.org/10.1016/j.tsep.2019.100460>.
- [25] Nazim Muradov, Low to near-zero CO₂ production of hydrogen from fossil fuels: Status and perspectives, *International Journal of Hydrogen Energy*, Volume 42, Issue 20, 2017, Pages 14058-14088, ISSN 0360-3199, <https://doi.org/10.1016/j.ijhydene.2017.04.101>.
- [26] Jiyuan Sui, Zhennan Chen, Chen Wang, Yueyang Wang, Jianhong Liu, Wenjia Li, Efficient hydrogen production from solar energy and fossil fuel via water-electrolysis and methane-steam-reforming hybridization, *Applied Energy*, Volume 276, 2020, 115409, ISSN 0306-2619, <https://doi.org/10.1016/j.apenergy.2020.115409>.
- [27] Chandan Mahata, Subhabrata Ray, Debabrata Das, Optimization of dark fermentative hydrogen production from organic wastes using acidogenic mixed consortia, *Energy Conversion and Management*, Volume 219, 2020, 113047, ISSN 0196-8904, <https://doi.org/10.1016/j.enconman.2020.113047>.
- [28] Yunus Emre Yuksel, Murat Ozturk, Ibrahim Dincer, Energy and exergy analyses of an integrated system using waste material gasification for hydrogen production and liquefaction, *Energy Conversion and Management*, Volume 185, 2019, Pages 718-729, ISSN 0196-8904, <https://doi.org/10.1016/j.enconman.2019.02.033>.
- [29] Canan Acar, Ibrahim Dincer, Review and evaluation of hydrogen production options for better environment, *Journal of Cleaner Production*, Volume 218, 2019, Pages 835-849, ISSN 0959-6526, <https://doi.org/10.1016/j.jclepro.2019.02.046>.

- [30] Jingwei Chen, Wenwen Xu, Hongyan Zuo, Xiaomin Wu, Jiaqiang E, Taosheng Wang, Feng Zhang, Na Lu, System development and environmental performance analysis of a solar-driven supercritical water gasification pilot plant for hydrogen production using life cycle assessment approach, *Energy Conversion and Management*, Volume 184, 2019, Pages 60-73, ISSN 0196-8904, <https://doi.org/10.1016/j.enconman.2019.01.041>.
- [31] Hadi Ganjehsarabi, Ali Gungor, Ibrahim Dincer, Exergetic performance analysis of Dora II geothermal power plant in Turkey, *Energy*, Volume 46, Issue 1, 2012, Pages 101-108, ISSN 0360-5442, <https://doi.org/10.1016/j.energy.2012.02.039>.
- [32] Tomasz Kowalczyk, Janusz Badur, Mateusz Bryk, Energy and exergy analysis of hydrogen production combined with electric energy generation in a nuclear cogeneration cycle, *Energy Conversion and Management*, Volume 198, 2019, 111805, ISSN 0196-8904, <https://doi.org/10.1016/j.enconman.2019.111805>.
- [33] Massimo Milani, Luca Montorsi, Gabriele Storch, Matteo Venturelli, Diego Angeli, Adriano Leonforte, Davide Castagnetti, Andrea Sorrentino, Experimental and Numerical Analysis of a Liquid Aluminium Injector for an Al-H₂O based Hydrogen Production System, *International Journal of Thermofluids*, 2020, 100018, ISSN 2666-2027, <https://doi.org/10.1016/j.ijft.2020.100018>.
- [34] Mohammed-Ibrahim Jamesh, Moussab Harb, Recent advances on hydrogen production through seawater electrolysis, *Materials Science for Energy Technologies*, 2020, ISSN 2589-2991, <https://doi.org/10.1016/j.mset.2020.09.005>.
- [35] Tomasz Wajda, Kamiel Gabriel, Thermolysis reactor scale-up for pilot scale CuCl hybrid hydrogen production, *International Journal of Hydrogen Energy*, Volume 44, Issue 20, 2019, Pages 9779-9790, ISSN 0360-3199, <https://doi.org/10.1016/j.ijhydene.2018.11.187>.
- [36] Tay Yu Cong, Abhijeet Raj, Jirawan Chanaphet, Shabin Mohammed, Salisu Ibrahim, Ahmed Al Shoaibi, A detailed reaction mechanism for hydrogen production via hydrogen sulphide (H₂S) thermolysis and oxidation, *International Journal of Hydrogen Energy*, Volume 41, Issue 16, 2016, Pages 6662-6675, ISSN 0360-3199, <https://doi.org/10.1016/j.ijhydene.2016.03.053>.
- [37] Seong-Heon Cho, Sang Soo Lee, Sungyup Jung, Young-Kwon Park, Kun-Yi Andrew Lin, Jechan Lee, Eilhann E. Kwon, Carbon dioxide-cofeeding pyrolysis of pine sawdust over nickel-based catalyst for hydrogen production, *Energy Conversion and Management*, Volume 201, 2019, 112140, ISSN 0196-8904, <https://doi.org/10.1016/j.enconman.2019.112140>.
- [38] Itsaso Barbarias, Gartzzen Lopez, Maite Artetxe, Aitor Arregi, Javier Bilbao, Martin Olazar, Valorisation of different waste plastics by pyrolysis and in-line catalytic steam reforming for hydrogen production, *Energy Conversion and Management*, Volume 156, 2018, Pages 575-584, ISSN 0196-8904, <https://doi.org/10.1016/j.enconman.2017.11.048>.
- [39] Francesco Lonis, Vittorio Tola, Giorgio Cau, Assessment of integrated energy systems for the production and use of renewable methanol by water electrolysis and CO₂

- hydrogenation, *Fuel*, Volume 285, 2021, 119160, ISSN 0016-2361, <https://doi.org/10.1016/j.fuel.2020.119160>.
- [40] Cong Zhang, Jeffery B. Greenblatt, Max Wei, Josh Eichman, Samveg Saxena, Matteo Muratori, Omar J. Guerra, Flexible grid-based electrolysis hydrogen production for fuel cell vehicles reduces costs and greenhouse gas emissions, *Applied Energy*, Volume 278, 2020, 115651, ISSN 0306-2619, <https://doi.org/10.1016/j.apenergy.2020.115651>.
- [41] Mohammad Khodabandehloo, Afsanehsadat Larimi, Farhad Khorasheh, Comparative process modeling and techno-economic evaluation of renewable hydrogen production by glycerol reforming in aqueous and gaseous phases, *Energy Conversion and Management*, Volume 225, 2020, 113483, ISSN 0196-8904, <https://doi.org/10.1016/j.enconman.2020.113483>.
- [42] Ememobog Essien, Hussameldin Ibrahim, Mehran Mehrandezh, Raphael Idem, Adaptive neuro-fuzzy inference system (ANFIS) – based model predictive control (MPC) for carbon dioxide reforming of methane (CDRM) in a plug flow tubular reactor for hydrogen production, *Thermal Science and Engineering Progress*, Volume 9, 2019, Pages 148-161, ISSN 2451-9049, <https://doi.org/10.1016/j.tsep.2018.11.010>.
- [43] Bhargav Manek, M.S. Javia, Atal Harichandan, Hardik Ramani, A CFD based comprehensive study of coal-fired updraft gasifier in ceramic industry, *Thermal Science and Engineering Progress*, Volume 9, 2019, Pages 11-20, ISSN 2451-9049, <https://doi.org/10.1016/j.tsep.2018.11.001>.
- [44] A.B.A. Ibrahim, H. Akilli, Supercritical water gasification of wastewater sludge for hydrogen production, *International Journal of Hydrogen Energy*, Volume 44, Issue 21, 2019, Pages 10328-10349, ISSN 0360-3199, <https://doi.org/10.1016/j.ijhydene.2019.02.184>.
- [45] Shidong Ban, Weitie Lin, Fangyan Wu, Jianfei Luo, Algal-bacterial cooperation improves algal photolysis-mediated hydrogen production, *Bioresource Technology*, Volume 251, 2018, Pages 350-357, ISSN 0960-8524, <https://doi.org/10.1016/j.biortech.2017.12.072>.
- [46] Shidong Ban, Weitie Lin, Jianfei Luo, Ca²⁺ enhances algal photolysis hydrogen production by improving the direct and indirect pathways, *International Journal of Hydrogen Energy*, Volume 44, Issue 3, 2019, Pages 1466-1473, ISSN 0360-3199, <https://doi.org/10.1016/j.ijhydene.2018.11.075>.
- [47] T. Nguyen, Z. Abdin, T. Holm, W. Mérida, Grid-connected hydrogen production via large-scale water electrolysis, *Energy Conversion and Management*, Volume 200, 2019, 112108, ISSN 0196-8904, <https://doi.org/10.1016/j.enconman.2019.112108>.
- [48] S. Shiva Kumar, V. Himabindu, Hydrogen production by PEM water electrolysis – A review, *Materials Science for Energy Technologies*, Volume 2, Issue 3, 2019, Pages 442-454, ISSN 2589-2991, <https://doi.org/10.1016/j.mset.2019.03.002>.

- [49] Kai Zeng, Dongke Zhang, Recent progress in alkaline water electrolysis for hydrogen production and applications, *Progress in Energy and Combustion Science*, Volume 36, Issue 3, 2010, Pages 307-326, ISSN 0360-1285, <https://doi.org/10.1016/j.peccs.2009.11.002>.
- [50] Zhoufeng Bian, Zhigang Wang, Bo Jiang, Plaifa Hongmanorom, Wenqi Zhong, Sibudjing Kawi, A review on perovskite catalysts for reforming of methane to hydrogen production, *Renewable and Sustainable Energy Reviews*, Volume 134, 2020, 110291, ISSN 1364-0321, <https://doi.org/10.1016/j.rser.2020.110291>.
- [51] Krystyna Bryś, Tadeusz Bryś, Marderos Ara Sayegh, Hanna Ojrzyńska, Characteristics of heat fluxes in subsurface shallow depth soil layer as a renewable thermal source for ground coupled heat pumps, *Renewable Energy*, Volume 146, 2020, Pages 1846-1866, ISSN 0960-1481, <https://doi.org/10.1016/j.renene.2019.07.101>.
- [52] Jann Michael Weinand, Max Kleinebrahm, Russell McKenna, Kai Mainzer, Wolf Fichtner, Developing a combinatorial optimisation approach to design district heating networks based on deep geothermal energy, *Applied Energy*, Volume 251, 2019, 113367, ISSN 0306-2619, <https://doi.org/10.1016/j.apenergy.2019.113367>.
- [53] Li-Hao Yang, Jyun-De Liang, Chien-Yeh Hsu, Tai-Her Yang, Sih-Li Chen, Enhanced efficiency of photovoltaic panels by integrating a spray cooling system with shallow geothermal energy heat exchanger, *Renewable Energy*, Volume 134, 2019, Pages 970-981, ISSN 0960-1481, <https://doi.org/10.1016/j.renene.2018.11.089>.
- [54] Javier Menéndez, Almudena Ordóñez, Rodrigo Álvarez, Jorge Loredó, Energy from closed mines: Underground energy storage and geothermal applications, *Renewable and Sustainable Energy Reviews*, Volume 108, 2019, Pages 498-512, ISSN 1364-0321, <https://doi.org/10.1016/j.rser.2019.04.007>.
- [55] Ayhan Atiz, Hatice Karakilcik, Mustafa Erden, Mehmet Karakilcik, Investigation energy, exergy and electricity production performance of an integrated system based on a low-temperature geothermal resource and solar energy, *Energy Conversion and Management*, Volume 195, 2019, Pages 798-809, ISSN 0196-8904, <https://doi.org/10.1016/j.enconman.2019.05.056>.
- [56] Roozbeh Sangi, Pooyan Jahangiri, Dirk Müller, A combined moving boundary and discretized approach for dynamic modeling and simulation of geothermal heat pump systems, *Thermal Science and Engineering Progress*, Volume 9, 2019, Pages 215-234, ISSN 2451-9049, <https://doi.org/10.1016/j.tsep.2018.11.015>.
- [57] Mohammadamin Ahmadfard, Michel Bernier, A review of vertical ground heat exchanger sizing tools including an inter-model comparison, *Renewable and Sustainable Energy Reviews*, Volume 110, 2019, Pages 247-265, ISSN 1364-0321, <https://doi.org/10.1016/j.rser.2019.04.045>.
- [58] Guohui Gan, A numerical methodology for comprehensive assessment of the dynamic thermal performance of horizontal ground heat exchangers, *Thermal Science and*

- Engineering Progress, Volume 11, 2019, Pages 365-379, ISSN 2451-9049, <https://doi.org/10.1016/j.tsep.2019.04.013>.
- [59] Guangqin Huang, Yajiao Liu, Chunlong Zhuang, Hongyu Zhang, Jun Lu, Liang Zhu, Experimental study on heat transfer characteristics of helix ground heat exchanger coil under dynamic load, *Thermal Science and Engineering Progress*, Volume 18, 2020, 100546, ISSN 2451-9049, <https://doi.org/10.1016/j.tsep.2020.100546>.
- [60] Kamal Kumar Agrawal, Rohit Misra, Ghanshyam Das Agrawal, Mayank Bhardwaj, Doraj Kamal Jamuwa, The state of art on the applications, technology integration, and latest research trends of earth-air-heat exchanger system, *Geothermics*, Volume 82, 2019, Pages 34-50, ISSN 0375-6505, <https://doi.org/10.1016/j.geothermics.2019.05.011>.
- [61] Namrata Bordoloi, Aashish Sharma, Himanshu Nautiyal, Varun Goel, An intense review on the latest advancements of Earth Air Heat Exchangers, *Renewable and Sustainable Energy Reviews*, Volume 89, 2018, Pages 261-280, ISSN 1364-0321, <https://doi.org/10.1016/j.rser.2018.03.056>.
- [62] Rodwan Elhashmi, Kevin P. Hallinan, Andrew D. Chiasson, Low-energy opportunity for multi-family residences: A review and simulation-based study of a solar borehole thermal energy storage system, *Energy*, Volume 204, 2020, 117870, ISSN 0360-5442, <https://doi.org/10.1016/j.energy.2020.117870>.
- [63] Paul Fleuchaus, Bas Godschalk, Ingrid Stober, Philipp Blum, Worldwide application of aquifer thermal energy storage – A review, *Renewable and Sustainable Energy Reviews*, Volume 94, 2018, Pages 861-876, ISSN 1364-0321, <https://doi.org/10.1016/j.rser.2018.06.057>.
- [64] Antonio Rosato, Antonio Ciervo, Giovanni Ciampi, Michelangelo Scorpio, Francesco Guarino, Sergio Sibilio, Impact of solar field design and back-up technology on dynamic performance of a solar hybrid heating network integrated with a seasonal borehole thermal energy storage serving a small-scale residential district including plug-in electric vehicles, *Renewable Energy*, Volume 154, 2020, Pages 684-703, ISSN 0960-1481, <https://doi.org/10.1016/j.renene.2020.03.053>.
- [65] Carlos Naranjo-Mendoza, Muyiwa A. Oyinlola, Andrew J. Wright, Richard M. Greenough, Experimental study of a domestic solar-assisted ground source heat pump with seasonal underground thermal energy storage through shallow boreholes, *Applied Thermal Engineering*, Volume 162, 2019, 114218, ISSN 1359-4311, <https://doi.org/10.1016/j.applthermaleng.2019.114218>.
- [66] Sadiq J. Zarrouk, Hyungsul Moon, Efficiency of geothermal power plants: A worldwide review, *Geothermics*, Volume 51, 2014, Pages 142-153, ISSN 0375-6505, <https://doi.org/10.1016/j.geothermics.2013.11.001>.
- [67] M. Fallah, R. Akbarpour Ghiasi, N. Hasani Mokarram, A comprehensive comparison among different types of geothermal plants from exergy and thermoeconomic points of

- view, *Thermal Science and Engineering Progress*, Volume 5, 2018, Pages 15-24, ISSN 2451-9049, <https://doi.org/10.1016/j.tsep.2017.10.017>.
- [68] Lukman Adi Prananto, Firman Bagja Juangsa, Riza Mochamad Iqbal, Muhammad Aziz, Tubagus Ahmad Fauzi Soelaiman, Dry steam cycle application for excess steam utilization: Kamojang geothermal power plant case study, *Renewable Energy*, Volume 117, 2018, Pages 157-165, ISSN 0960-1481, <https://doi.org/10.1016/j.renene.2017.10.029>.
- [69] Emilio Hernández Martínez, M.C. Patricia Avitia Carlos, José Isaac Cisneros Solís, M.C. María del Carmen Prieto Avalos, Thermodynamic simulation and mathematical model for single and double flash cycles of Cerro Prieto geothermal power plants, *Geothermics*, Volume 83, 2020, 101713, ISSN 0375-6505, <https://doi.org/10.1016/j.geothermics.2019.101713>.
- [70] N. Nasruddin, Irfan Dwi Saputra, Tania Mentari, André Bardow, Olga Marcelina, Susanto Berlin, Exergy, exergoeconomic, and exergoenvironmental optimization of the geothermal binary cycle power plant at Ampallas, West Sulawesi, Indonesia, *Thermal Science and Engineering Progress*, Volume 19, 2020, 100625, ISSN 2451-9049, <https://doi.org/10.1016/j.tsep.2020.100625>.
- [71] V. Zare, A comparative exergoeconomic analysis of different ORC configurations for binary geothermal power plants, *Energy Conversion and Management*, Volume 105, 2015, Pages 127-138, ISSN 0196-8904, <https://doi.org/10.1016/j.enconman.2015.07.073>.
- [72] Saeid Mohammadzadeh Bina, Saeid Jalilinasrabady, Hikari Fujii, Energy, economic and environmental (3E) aspects of internal heat exchanger for ORC geothermal power plants, *Energy*, Volume 140, Part 1, 2017, Pages 1096-1106, ISSN 0360-5442, <https://doi.org/10.1016/j.energy.2017.09.045>.
- [73] Hamoda Gnaifaid, Hasan Ozcan, Development and multiobjective optimization of an integrated flash-binary geothermal power plant with reverse osmosis desalination and absorption refrigeration for multi-generation, *Geothermics*, Volume 89, 2021, 101949, ISSN 0375-6505, <https://doi.org/10.1016/j.geothermics.2020.101949>.
- [74] Lingbao Wang, Huashan Li, Xianbiao Bu, Thermo-economic investigation of binary flashing cycle for enhanced geothermal system, *Geothermics*, Volume 89, 2021, 101951, ISSN 0375-6505, <https://doi.org/10.1016/j.geothermics.2020.101951>.
- [75] Krystyna Bryś, Tadeusz Bryś, Marderos Ara Sayegh, Hanna Ojrzyńska, Subsurface shallow depth soil layers thermal potential for ground heat pumps in Poland, *Energy and Buildings*, Volume 165, 2018, Pages 64-75, ISSN 0378-7788, <https://doi.org/10.1016/j.enbuild.2018.01.015>.
- [76] A. Khosravi, S. Syri, Modeling of geothermal power system equipped with absorption refrigeration and solar energy using multilayer perceptron neural network optimized with imperialist competitive algorithm, *Journal of Cleaner Production*, Volume 276, 2020, 124216, ISSN 0959-6526, <https://doi.org/10.1016/j.jclepro.2020.124216>.

- [77] Francesco Calise, Francesco Liberato Cappiello, Massimo Dentice d'Accadia, Maria Vicidomini, Energy and economic analysis of a small hybrid solar-geothermal trigeneration system: A dynamic approach, *Energy*, Volume 208, 2020, 118295, ISSN 0360-5442, <https://doi.org/10.1016/j.energy.2020.118295>.
- [78] Ceyhun Yilmaz, Ismail Koyuncu, Murat Alcin, Murat Tuna, Artificial Neural Networks based thermodynamic and economic analysis of a hydrogen production system assisted by geothermal energy on Fiel Programmable Gate Array, *International Journal of Hydrogen Energy*, Volume 44, Issue 33, 2019, Pages 17443-17459, ISSN 0360-3199, <https://doi.org/10.1016/j.ijhydene.2019.05.049>.
- [79] Ceyhun Yilmaz, Mehmet Kanoglu, Thermodynamic evaluation of geothermal energy powered hydrogen production by PEM water electrolysis, *Energy*, Volume 69, 2014, Pages 592-602, ISSN 0360-5442, <https://doi.org/10.1016/j.energy.2014.03.054>.
- [80] Liyan Cao, Juwei Lou, Jiangfeng Wang, Yiping Dai, Exergy analysis and optimization of a combined cooling and power system driven by geothermal energy for ice-making and hydrogen production, *Energy Conversion and Management*, Volume 174, 2018, Pages 886-896, ISSN 0196-8904, <https://doi.org/10.1016/j.enconman.2018.08.067>.
- [81] Ceyhun Yilmaz, Mehmet Kanoglu, Aysegul Abusoglu, Thermoeconomic cost evaluation of hydrogen production driven by binary geothermal power plant, *Geothermics*, Volume 57, 2015, Pages 18-25, ISSN 0375-6505, <https://doi.org/10.1016/j.geothermics.2015.05.005>.
- [82] Ceyhun Yilmaz, Mehmet Kanoglu, Aysegul Abusoglu, Exergetic cost evaluation of hydrogen production powered by combined flash-binary geothermal power plant, *International Journal of Hydrogen Energy*, Volume 40, Issue 40, 2015, Pages 14021-14030, ISSN 0360-3199, <https://doi.org/10.1016/j.ijhydene.2015.07.031>.
- [83] Yunus Emre Yuksel, Murat Ozturk, Ibrahim Dincer, Energetic and exergetic performance evaluations of a geothermal power plant based integrated system for hydrogen production, *International Journal of Hydrogen Energy*, Volume 43, Issue 1, 2018, Pages 78-90, ISSN 0360-3199, <https://doi.org/10.1016/j.ijhydene.2017.11.002>.
- [84] Mohammad Ebadollahi, Hadi Rostamzadeh, Mona Zamani Pedram, Hadi Ghaebi, Majid Amidpour, Proposal and assessment of a new geothermal-based multigeneration system for cooling, heating, power, and hydrogen production, using LNG cold energy recovery, *Renewable Energy*, Volume 135, 2019, Pages 66-87, ISSN 0960-1481, <https://doi.org/10.1016/j.renene.2018.11.108>.
- [85] Ceyhun Yilmaz, Thermoeconomic modeling and optimization of a hydrogen production system using geothermal energy, *Geothermics*, Volume 65, 2017, Pages 32-43, ISSN 0375-6505, <https://doi.org/10.1016/j.geothermics.2016.08.008>.
- [86] Yan Cao, Maghsoud Abdollahi Haghghi, Masood Shamsaiee, Hassan Athari, Mohsen Ghaemi, Marc A. Rosen, Evaluation and optimization of a novel geothermal-driven hydrogen production system using an electrolyser fed by a two-stage organic Rankine cycle

with different working fluids, *Journal of Energy Storage*, Volume 32, 2020, 101766, ISSN 2352-152X, <https://doi.org/10.1016/j.est.2020.101766>.

- [87] Hadi Ghaebi, Behzad Farhang, Towhid Parikhani, Hadi Rostamzadeh, Energy, exergy and exergoeconomic analysis of a cogeneration system for power and hydrogen production purpose based on TRR method and using low grade geothermal source, *Geothermics*, Volume 71, 2018, Pages 132-145, ISSN 0375-6505, <https://doi.org/10.1016/j.geothermics.2017.08.011>.
- [88] E. Gholamian, A. Habibollahzade, V. Zare, Development and multi-objective optimization of geothermal-based organic Rankine cycle integrated with thermoelectric generator and proton exchange membrane electrolyzer for power and hydrogen production, *Energy Conversion and Management*, Volume 174, 2018, Pages 112-125, ISSN 0196-8904, <https://doi.org/10.1016/j.enconman.2018.08.027>.
- [89] Abderrahmane Gouareh, Nouredine Settou, Ali Khalfi, Bakhta Recioui, Belkhir Negrou, Soumia Rahmouni, Boubekeur Dokkar, GIS-based analysis of hydrogen production from geothermal electricity using CO₂ as working fluid in Algeria, *International Journal of Hydrogen Energy*, Volume 40, Issue 44, 2015, Pages 15244-15253, ISSN 0360-3199, <https://doi.org/10.1016/j.ijhydene.2015.05.105>.
- [90] Jing Han, Xi Wang, Jianjun Xu, Na Yi, Seyed Saman Ashraf Taleh, Thermodynamic analysis and optimization of an innovative geothermal-based organic Rankine cycle using zeotropic mixtures for power and hydrogen production, *International Journal of Hydrogen Energy*, Volume 45, Issue 15, 2020, Pages 8282-8299, ISSN 0360-3199, <https://doi.org/10.1016/j.ijhydene.2020.01.093>.
- [91] Hatice Karakilcik, Mustafa Erden, Mehmet Karakilcik, Investigation of hydrogen production performance of chlor-alkali cell integrated into a power generation system based on geothermal resources, *International Journal of Hydrogen Energy*, Volume 44, Issue 27, 2019, Pages 14145-14150, ISSN 0360-3199, <https://doi.org/10.1016/j.ijhydene.2018.09.095>.
- [92] Aras Karapekmez, Ibrahim Dincer, Modelling of hydrogen production from hydrogen sulfide in geothermal power plants, *International Journal of Hydrogen Energy*, Volume 43, Issue 23, 2018, Pages 10569-10579, ISSN 0360-3199, <https://doi.org/10.1016/j.ijhydene.2018.02.020>.
- [93] Shoaib Khanmohammadi, Morteza Saadat-Targhi, Faraedoon Waly Ahmed, Masoud Afrand, Potential of thermoelectric waste heat recovery in a combined geothermal, fuel cell and organic Rankine flash cycle (thermodynamic and economic evaluation), *International Journal of Hydrogen Energy*, Volume 45, Issue 11, 2020, Pages 6934-6948, ISSN 0360-3199, <https://doi.org/10.1016/j.ijhydene.2019.12.113>.
- [94] Hossein Kianfard, Shahram Khalilarya, Samad Jafarmadar, Exergy and exergoeconomic evaluation of hydrogen and distilled water production via combination of PEM electrolyzer, RO desalination unit and geothermal driven dual fluid ORC, *Energy Conversion and*

- Management, Volume 177, 2018, Pages 339-349, ISSN 0196-8904, <https://doi.org/10.1016/j.enconman.2018.09.057>.
- [95] Zhixiong Li, Shoaib Khanmohammadi, Saber Khanmohammadi, Abdullah A.A.A. Al-Rashed, Pouria Ahmadi, Masoud Afrand, 3-E analysis and optimization of an organic rankine flash cycle integrated with a PEM fuel cell and geothermal energy, *International Journal of Hydrogen Energy*, Volume 45, Issue 3, 2020, Pages 2168-2185, ISSN 0360-3199, <https://doi.org/10.1016/j.ijhydene.2019.09.233>.
- [96] T.A.H. Ratlamwala, I. Dincer, Comparative efficiency assessment of novel multi-flash integrated geothermal systems for power and hydrogen production, *Applied Thermal Engineering*, Volume 48, 2012, Pages 359-366, ISSN 1359-4311, <https://doi.org/10.1016/j.applthermaleng.2012.04.039>.
- [97] Shaimaa Seyam, Ibrahim Dincer, Martin Agelin-Chaab, Analysis of a clean hydrogen liquefaction plant integrated with a geothermal system, *Journal of Cleaner Production*, Volume 243, 2020, 118562, ISSN 0959-6526, <https://doi.org/10.1016/j.jclepro.2019.118562>.
- [98] Ceyhun Yilmaz, Life cycle cost assessment of a geothermal power assisted hydrogen energy system, *Geothermics*, Volume 83, 2020, 101737, ISSN 0375-6505, <https://doi.org/10.1016/j.geothermics.2019.101737>.
- [99] Ceyhun Yilmaz, Mehmet Kanoglu, Ali Bolatturk, Mohamed Gadalla, Economics of hydrogen production and liquefaction by geothermal energy, *International Journal of Hydrogen Energy*, Volume 37, Issue 2, 2012, Pages 2058-2069, ISSN 0360-3199, <https://doi.org/10.1016/j.ijhydene.2011.06.037>.
- [100] Yunus Emre Yuksel, Murat Ozturk, Thermodynamic and thermoeconomic analyses of a geothermal energy based integrated system for hydrogen production, *International Journal of Hydrogen Energy*, Volume 42, Issue 4, 2017, Pages 2530-2546, ISSN 0360-3199, <https://doi.org/10.1016/j.ijhydene.2016.04.172>.
- [101] Yunus Emre Yuksel, Murat Ozturk, Ibrahim Dincer, Analysis and performance assessment of a combined geothermal power-based hydrogen production and liquefaction system, *International Journal of Hydrogen Energy*, Volume 43, Issue 22, 2018, Pages 10268-10280, ISSN 0360-3199, <https://doi.org/10.1016/j.ijhydene.2018.01.088>.
- [102] Yunus Emre Yuksel, Murat Ozturk, Ibrahim Dincer, Thermodynamic analysis and assessment of a novel integrated geothermal energy-based system for hydrogen production and storage, *International Journal of Hydrogen Energy*, Volume 43, Issue 9, 2018, Pages 4233-4243, ISSN 0360-3199, <https://doi.org/10.1016/j.ijhydene.2017.08.137>.
- [103] Hadi Ganjehsarabi, Mixed refrigerant as working fluid in Organic Rankine Cycle for hydrogen production driven by geothermal energy, *International Journal of Hydrogen Energy*, Volume 44, Issue 34, 2019, Pages 18703-18711, ISSN 0360-3199, <https://doi.org/10.1016/j.ijhydene.2018.11.231>.

- [104] Ayhan Atiz, Comparison of three different solar collectors integrated with geothermal source for electricity and hydrogen production, *International Journal of Hydrogen Energy*, 2020, ISSN 0360-3199, <https://doi.org/10.1016/j.ijhydene.2020.08.236>.
- [105] Osamah Siddiqui, Haris Ishaq, Ibrahim Dincer, A novel solar and geothermal-based trigeneration system for electricity generation, hydrogen production and cooling, *Energy Conversion and Management*, Volume 198, 2019, 111812, ISSN 0196-8904, <https://doi.org/10.1016/j.enconman.2019.111812>.
- [106] Mert Temiz, Ibrahim Dincer, Techno-economic assessment of bifacial photovoltaic and geothermal based multigeneration system for cleaner communities, *Journal of Cleaner Production*, Volume 275, 2020, 122879, ISSN 0959-6526, <https://doi.org/10.1016/j.jclepro.2020.122879>.
- [107] M. Al-Ali, I. Dincer, Energetic and exergetic studies of a multigenerational solar–geothermal system, *Applied Thermal Engineering*, Volume 71, Issue 1, 2014, Pages 16-23, ISSN 1359-4311, <https://doi.org/10.1016/j.applthermaleng.2014.06.033>.
- [108] Yusuf Bicer, Ibrahim Dincer, Development of a new solar and geothermal based combined system for hydrogen production, *Solar Energy*, Volume 127, 2016, Pages 269-284, ISSN 0038-092X, <https://doi.org/10.1016/j.solener.2016.01.031>.
- [109] Burak Kurşun, Energy and exergy analysis of a concentrated photovoltaic recuperator design for a geothermal based multi-generation system, *Applied Thermal Engineering*, Volume 181, 2020, 115932, ISSN 1359-4311, <https://doi.org/10.1016/j.applthermaleng.2020.115932>.
- [110] Sheharyar Waseem, Tahir Abdul Hussain Ratlamwala, Yawar Salman, Abdallah Ayub Bham, Geothermal and solar based multigenerational system: A comparative analysis, *International Journal of Hydrogen Energy*, Volume 45, Issue 9, 2020, Pages 5636-5652, ISSN 0360-3199, <https://doi.org/10.1016/j.ijhydene.2019.06.135>.
- [111] Osamah Siddiqui, Ibrahim Dincer, A new solar and geothermal based integrated ammonia fuel cell system for multigeneration, *International Journal of Hydrogen Energy*, 2020, ISSN 0360-3199, <https://doi.org/10.1016/j.ijhydene.2020.02.109>.
- [112] Moh'd A. Al-Nimr, Mohammad Bukhari, Mansour Mansour, A combined CPV/T and ORC solar power generation system integrated with geothermal cooling and electrolyser/fuel cell storage unit, *Energy*, Volume 133, 2017, Pages 513-524, ISSN 0360-5442, <https://doi.org/10.1016/j.energy.2017.05.142>.
- [113] Aras Karapekmez, Ibrahim Dincer, Thermodynamic analysis of a novel solar and geothermal based combined energy system for hydrogen production, *International Journal of Hydrogen Energy*, Volume 45, Issue 9, 2020, Pages 5608-5628, ISSN 0360-3199, <https://doi.org/10.1016/j.ijhydene.2018.12.046>.
- [114] Jamil Jannati, Daryoosh Nazarpour, Optimal energy management of the smart parking lot under demand response program in the presence of the electrolyser and fuel cell as

hydrogen storage system, *Energy Conversion and Management*, Volume 138, 2017, Pages 659-669, ISSN 0196-8904, <https://doi.org/10.1016/j.enconman.2017.02.030>.

- [115] Sayyad Nojavan, Kazem Zare, Behnam Mohammadi-Ivatloo, Application of fuel cell and electrolyzer as hydrogen energy storage system in energy management of electricity energy retailer in the presence of the renewable energy sources and plug-in electric vehicles, *Energy Conversion and Management*, Volume 136, 2017, Pages 404-417, ISSN 0196-8904, <https://doi.org/10.1016/j.enconman.2017.01.017>.