



## City Research Online

### City, University of London Institutional Repository

---

**Citation:** Rahman, B. M. & Agrawal, A. (2013). Introduction. In: Rahman, B. M. & Agrawal, A. (Eds.), *Finite Element Modeling Methods for Photonics*. (pp. 1-19). London, UK: Artech House. ISBN 9781608075317

This is the unspecified version of the paper.

This version of the publication may differ from the final published version.

---

**Permanent repository link:** <https://openaccess.city.ac.uk/id/eprint/2607/>

**Link to published version:**

**Copyright:** City Research Online aims to make research outputs of City, University of London available to a wider audience. Copyright and Moral Rights remain with the author(s) and/or copyright holders. URLs from City Research Online may be freely distributed and linked to.

**Reuse:** Copies of full items can be used for personal research or study, educational, or not-for-profit purposes without prior permission or charge. Provided that the authors, title and full bibliographic details are credited, a hyperlink and/or URL is given for the original metadata page and the content is not changed in any way.

---

---

---

City Research Online:

<http://openaccess.city.ac.uk/>

[publications@city.ac.uk](mailto:publications@city.ac.uk)

---

# 1

## Introduction

In this chapter, we introduce the reader to the need and importance of numerical modeling in photonics and mention a few methods that are popular. The main thrust of the chapter is to explain in simple language some of the basic assumptions and simplifications made to Maxwell's equations and the methods obtained thus. These physical insights accompany the mathematical treatment. Furthermore, we discuss the applicability and limitations of the various classes of methods. We discuss the criteria important in selecting a modeling method and assess the finite element method against these.

### 1.1 Significance of Numerical Methods

The development of photonic devices involves a time-consuming cycle of design, fabrication, characterization and possible redesign. The role of computerized modeling and simulation tools is important in reducing the time and costs involved in this cycle as well as in investigating novel phenomena that may not lend themselves to experimental study with current technology. Simulation tools play a part in optimization of the physical parameters, in characterization and in improving efficiency of the device. Much progress has been made in the field of modeling and simulation techniques in photonics. A description of some of these is given in the literature [1–14]. Both analytical and numerical methods have been studied, new techniques developed, and existing techniques have been improved. Based on such techniques, commercial simulation tools and software have also become available and are popular in the market. These tools have to be accurate, fast, robust, and easy-to-use

with minimum computation and memory requirement as much as possible. The following sections briefly detail some of the most widely used methods.

## 1.2 Numerical Methods

There is an immense variety in the numerical methods available for modeling of photonic devices to suit the needs of users. The different techniques have origins in physics, engineering and mathematics, and many have been applied successfully in several disciplines. Historically, closed-form solutions and analytical methods were used for modeling phenomena/devices to a large extent. As devices became progressively more complicated and the applicability of analytical methods became limited, approximations led to numerical methods. This was complemented by tremendous growth in low-cost computing power, which led to automation or computerizing of numerical algorithms. Thus, in recent years it has become possible to simulate highly intricate devices accurately using computerized codes based on different numerical methods.

Some of the most widely used numerical methods for passive devices include Galerkin and moment methods [15–18], transfer matrix method [19], finite-element-based methods [20, 21], finite-difference-based methods [22–24], transmission line matrix methods [24–26], and stochastic methods such as the Monte Carlo method [27] (this is not an exhaustive list). All these methods solve some form of the Maxwell's equations, which is hence the natural starting point for any discussion on numerical methods.

Accordingly, we start with the Maxwellian curl equations and refresh some of the basic concepts in modeling of optical or electromagnetic fields. We discuss briefly a few classes of modeling methods: the approximations and assumptions inherent and their applicability.

## 1.3 Maxwell's Equations and Boundary Conditions

### 1.3.1 Maxwell's Equations

The evolution of electromagnetic fields is described by Maxwell's equations. These first-order differential equations are coupled, reflecting the intimate interaction between the electric and magnetic fields, where the change in one field with time leads to the evolution of the other. Thus, Maxwell's equations describe fields that vary in space in a time-dependent manner. The general differential form of Maxwell's equations in a homogeneous, lossless dielectric medium is:

$$\text{Faraday's law} \quad \nabla \times \mathbf{E} = \frac{-\partial \mathbf{B}}{\partial t} \quad (1.1)$$

$$\text{Maxwell-Ampere law} \quad \nabla \times \mathbf{H} = \frac{\partial \mathbf{D}}{\partial t} + \mathbf{J} \quad (1.2)$$

$$\text{Gauss's law} \quad \nabla \cdot \mathbf{D} = \rho \quad (1.3)$$

$$\text{Gauss's law—magnetic} \quad \nabla \cdot \mathbf{B} = 0 \quad (1.4)$$

where

$\mathbf{H}$ : Magnetic field intensity (amperes/meter)

$\mathbf{E}$ : electric field intensity (volts/meter)

$\mathbf{D}$ : electric flux density (coulombs/meter<sup>2</sup>)

$\mathbf{B}$ : magnetic flux density (webers/meter<sup>2</sup>)

$\mathbf{J}$ : electric current density (amperes/meter<sup>2</sup>)

$\rho$ : electric charge density (coulombs/meter<sup>3</sup>)

The conservation of charge or the continuity of current can be expressed (holds for  $\mathbf{J}$  and the charge density,  $\rho$ ) as

$$\nabla \cdot \mathbf{J} = \frac{-\partial \rho}{\partial t} \quad (1.5)$$

The associated constitutive relations for the medium are:

$$\mathbf{D} = \hat{\epsilon} \mathbf{E} \quad (1.6)$$

$$\mathbf{B} = \hat{\mu} \mathbf{H} \quad (1.7)$$

where  $\hat{\epsilon}$  and  $\hat{\mu}$  represent the permittivity and permeability of the medium, respectively, and can be tensors but for simplicity we shall write  $\epsilon$ ,  $\mu$ . The photonics community is in general interested in solutions of Maxwell's equations, not in free space or one continuous medium, but in a variety of devices such as optical fibers, Bragg gratings, slot waveguides, vertical cavity surface emitting lasers (VCSELs), and many others. These photonic components have one feature in common: the device usually contains more than one material medium, and there are several *boundaries* between the different media. In

accounting for the continuity conditions of the electric and magnetic fields inside such devices, boundary conditions have to be incorporated.

### 1.3.2 Boundary Conditions across Material Interfaces

In the absence of surface charges ( $\rho = 0$ ) and surface currents ( $\mathbf{J} = 0$ ), the boundary conditions are the following:

1. The tangential components of the electric field must be continuous.

$$\begin{aligned} \mathbf{n} \times (\mathbf{E}_1 - \mathbf{E}_2) &= 0 & (1.8) \\ \therefore \mathbf{E}_{t1} &= \mathbf{E}_{t2} \end{aligned}$$

2. The tangential components of the magnetic field must be continuous.

$$\begin{aligned} \mathbf{n} \times (\mathbf{H}_1 - \mathbf{H}_2) &= 0 & (1.9) \\ \therefore \mathbf{H}_{t1} &= \mathbf{H}_{t2} \end{aligned}$$

3. The normal components of the electric flux density must be continuous.

$$\begin{aligned} \mathbf{n} \cdot (\mathbf{D}_1 - \mathbf{D}_2) &= 0 & (1.10) \\ \therefore \mathbf{D}_{n1} &= \mathbf{D}_{n2} \end{aligned}$$

$$\therefore \epsilon_1 \mathbf{E}_{n1} = \epsilon_2 \mathbf{E}_{n2} \Rightarrow \therefore \mathbf{E}_{n1} \neq \mathbf{E}_{n2} \quad (1.11)$$

where  $\epsilon_1$  and  $\epsilon_2$  are the permittivity in medium 1 and 2, respectively. At the interface,  $\epsilon_1 \neq \epsilon_2$ . We also point out here that the permittivity and refractive index are related ( $\epsilon_r = n^2$ ). We use these terms interchangeably to define the optical response of a medium.

4. The normal components of the magnetic flux density must be continuous.

$$\begin{aligned} \mathbf{n} \cdot (\mathbf{B}_1 - \mathbf{B}_2) &= 0 & (1.12) \\ \therefore \mathbf{B}_{n1} &= \mathbf{B}_{n2} \\ \therefore \mu_1 \mathbf{H}_{n1} &= \mu_2 \mathbf{H}_{n2} \end{aligned}$$

where  $\mu_1$  and  $\mu_2$  are the relative permeability in medium 1 and medium 2, respectively and for most nonmagnetic media,  $\mu_1 = \mu_2 = 1$ .

$$\therefore \mathbf{H}_{n1} = \mathbf{H}_{n2} \quad (1.13)$$

Equation (1.13) implies equality of the normal component of the magnetic field vectors at the boundary.

In addition, we include two more boundary conditions that are encountered in practical waveguide problems.

Perfect electric conductor (PEC) or electric wall (EW)—the electric field is continuous across the boundary:

$$\mathbf{n} \times \mathbf{E} = 0 \quad \text{or} \quad \mathbf{n} \cdot \mathbf{H} = 0 \quad (1.14)$$

In the absence of surface currents, this boundary condition requires that certain magnetic field vector components must vanish. That is  $\mathbf{H}_n = 0$ , in the absence of surface currents  $\mathbf{J} = 0$  and  $\mathbf{H}_t = 0$ .

Perfect magnetic conductor (PMC) or magnetic wall (MW)—when one of the two media becomes a perfect magnetic conductor:

$$\mathbf{n} \times \mathbf{H} = 0 \quad \text{or} \quad \mathbf{n} \cdot \mathbf{E} = 0 \quad (1.15)$$

This condition ensures the continuity of the magnetic field component,  $\mathbf{H}$ , at the boundary, while the electric field vector,  $\mathbf{E}$ , vanishes.

Solutions of Maxwell's equations satisfy the constitutive relations and the boundary conditions, and describe completely the electromagnetic fields inside any photonic device. These conditions also ensure that the solution found is unique.

In the section below, we make a brief detour to classify boundary conditions in the nomenclature of partial differential equations. This general classification describes the nature of the field (and in some cases its derivative) values at the boundary of the computational domain. For any given electromagnetic problem/domain, classifying the boundary conditions helps in choosing the appropriate solution technique.

### 1.3.3 Boundary Conditions: Natural and Forced

Boundary conditions can be classified based on mathematical representation and the conditions imposed upon the formulation. The boundaries can be left free, when the field decays at the boundary and the conditions are termed

as *natural*. In other cases, the field values have to be explicitly defined at the boundaries. This may be to take advantage of the symmetry of a waveguide, to reduce the number of elements in finite-element method (FEM) (and corresponding order of the matrices). Such boundary conditions are called *forced* and are classified as

$$\text{Homogeneous Dirichlet} \quad \varphi = 0 \quad (1.16)$$

$$\text{Inhomogeneous Dirichlet} \quad \varphi = k \quad (1.17)$$

where  $\varphi$  is a specific component of the vector electric or magnetic field and  $k$  is a prescribed constant value.

$$\text{Homogeneous Neumann} \quad \partial\varphi/\partial\mathbf{n} = 0 \quad (1.18)$$

where  $\mathbf{n}$  is the unit vector normal to the surface.

The Neumann boundary condition represents the rate of change of the field when it is directed out of the surface. The importance of classifying boundary conditions in this manner lies in the impact they have upon the way the FEM formulation is set up.

### 1.3.4 Boundary Conditions: Truncation of Domains

We have described the role of boundaries that separate a device into regions of distinct electromagnetic properties, as well as natural/forced boundary conditions. However, we are also concerned about the boundaries at *infinity*. By these we mean that the device has a finite extent in the  $x$ ,  $y$ , and  $z$  directions even though the surrounding space extends to infinity. Therefore the boundaries of the outer domains of the device/surrounding space require special care in order for the fields (and physical quantities of interest including power and energy) to be well defined and a unique solution to exist. Where purely artificial boundaries are imposed to limit the computational domain to a finite size, during simulation, optical fields travelling toward these boundaries are reflected back into the computational domain. Thus, these boundaries have to be made absorbing in nature to minimize this unphysical reflection, which is a purely numerical feature. Absorbing boundary conditions including the transparent boundary conditions (TBC) [28, 29], perfectly matched layer boundary condition (PML) [30, 31] and others [32, 33] have been devised to deal with this problem. This results in modifications in the wave equations (to be derived later). We do not include the mathematical considerations



imposed by these boundary conditions here to keep this introduction simple. We do however describe in detail how these conditions are implemented in the FEM in Chapter 2.

To obtain the behavior of the fields inside the device described by the solution to Maxwell's equations, (1.1)–(1.4) can be recast into an appropriate form that reflects physical considerations as well as practical ones related to the mathematical solution. In the following, we comment briefly on the solution techniques and the approximations required.

## 1.4 Basic Assumptions of Numerical Methods and Their Applicability

### 1.4.1 Time Harmonic and Time-Dependent Solutions

The coupled differential equation format of Maxwell's equations naturally gives a description of the spatial and temporal evolution of both the electric and magnetic fields. Thus, it is an appropriate framework for study of time-dependent phenomena, such as pulse propagation, reflections, radar, antennae, and through inclusion of the required functional forms of the permittivity ( $\epsilon$ ) and permeability ( $\mu$ ), the evolution of the fields in exotic systems such as metamaterials.

However, for many practical applications, we are interested in the steady state or equilibrium behavior of the optical field only as a function of the physical coordinates. This translates to the concept of time harmonic fields, where our interest is in continuous wave (CW) operation at a single frequency; time evolution can be neglected, and hence removed from the analysis. The fields can be written in phasor representation:

$$\begin{bmatrix} \mathbf{E}(x, y, z, t) \\ \mathbf{D}(x, y, z, t) \\ \mathbf{H}(x, y, z, t) \\ \mathbf{B}(x, y, z, t) \end{bmatrix} = \begin{bmatrix} \mathbf{E}(x, y, z) \\ \mathbf{D}(x, y, z) \\ \mathbf{H}(x, y, z) \\ \mathbf{B}(x, y, z) \end{bmatrix} e^{j\omega t} \quad (1.19)$$

The use of the phasor representation allows replacing the time derivatives in (1.1) and (1.2) by the term  $j\omega$  (after suppressing  $e^{j\omega t}$  on both sides of the equation) since

$$\frac{\partial e^{j\omega t}}{\partial t} = j\omega e^{j\omega t}$$

Thus, (1.1)–(1.4) can be rewritten in the form

$$\nabla \times \mathbf{E} = -j\omega\mathbf{B} \quad (1.20)$$

$$\nabla \times \mathbf{H} = j\omega\mathbf{D} + \mathbf{J} \quad (1.21)$$

$$\nabla \cdot \mathbf{D} = \rho \quad (1.22)$$

$$\nabla \cdot \mathbf{B} = 0 \quad (1.23)$$

and the continuity equation becomes

$$\nabla \cdot \mathbf{J} = -j\omega\rho \quad (1.24)$$

However, time variation of a non sinusoidal field can also be accounted for by summing all the Fourier components over the frequency,  $\omega$ , if the system is linear.

### 1.4.2 The Wave Equations

The solution of a system of coupled differential equations with boundary conditions is not always an easy task [11]. Additionally, in computer implementations of the solution, storage of six field components (three each for the electric and magnetic fields) at every point in the physical domain of the device may not be feasible for devices of practical size. Thus, a standard procedure is to decouple the first-order Maxwellian curl equations, (1.1)–(1.4), to obtain second-order differential equations for only one field, called the wave equations.

We eliminate  $\mathbf{H}$  from (1.1) by use of the constitutive relations [(1.7)].

We can write  $\nabla \times \mathbf{E} = -\mu \frac{\partial \mathbf{H}}{\partial t}$  and applying the curl operator to both sides,  $\nabla \times (\nabla \times \mathbf{E}) = -\mu \frac{\partial}{\partial t} [\nabla \times \mathbf{H}]$ . Substituting (1.2) we get

$$\nabla \times (\nabla \times \mathbf{E}) = \omega^2 \epsilon \mu \mathbf{E} \quad (1.25)$$

A similar approach is followed to eliminate  $\mathbf{E}$  and obtain

$$\nabla \times \frac{1}{\epsilon} (\nabla \times \mathbf{H}) = \omega^2 \mu \epsilon \mathbf{H} \quad (1.26)$$

Further, using the vector identity  $\nabla \times (\nabla \times \mathbf{A}) = \nabla(\nabla \cdot \mathbf{A}) - \nabla^2 \mathbf{A}$  and rewriting  $\nabla(\nabla \cdot \mathbf{E}) = -\nabla(\ln \epsilon) \cdot \mathbf{E}$  yields the vector wave equations:

$$\nabla^2 \mathbf{E} + \omega^2 \epsilon \mu \mathbf{E} = -\nabla(\ln \epsilon) \cdot \mathbf{E} \quad (1.27)$$

$$\nabla^2 \mathbf{H} + \omega^2 \epsilon \mu \mathbf{H} = -\nabla(\ln \epsilon) \times \nabla \times \mathbf{H} \quad (1.28)$$

### 1.4.3 Scalar and Vector Nature of the Equations/Solutions

Having obtained second-order *vector* wave equations, before we describe procedures to solve these we need to understand some key concepts embedded in the equations. The electric and magnetic fields in (1.27) and (1.28) are vectors; that is, the magnitude and directional dependence play a part in the nature of the field and its mathematical description. In general, the vector field (also known as the hybrid field) contains both longitudinal (along the direction of propagation) and transverse (normal to the direction of propagation) components that are coupled. The terms on the right-hand side of (1.27) and (1.28) describe the coupling of the components. In homogeneous media,  $\nabla \cdot \epsilon = 0$  and the right-hand side (RHS) vanishes, leading to the decoupling of the transverse and longitudinal components of the fields. For inhomogeneous media, however, when the term on the RHS can be neglected in comparison to the other terms, called the scalar or weakly guiding approximation (that is, when  $\frac{\nabla \epsilon}{\epsilon}$ ,  $\frac{\nabla \mu}{\mu}$  are small compared with the length scale over which  $\mathbf{E}$  and  $\mathbf{H}$  evolve in space) it also leads to decoupling of the transverse and longitudinal components:

$$\nabla^2 \mathbf{E} = \omega^2 \epsilon \mu \mathbf{E} \quad (1.29)$$

$$\nabla^2 \mathbf{H} = \omega^2 \epsilon \mu \mathbf{H} \quad (1.30)$$

Equation (1.29) is homogeneous and represents the scalar wave equation for the electric field. The field components in the solution of these equations are decoupled from each other and are transverse; thus, the longitudinal components are negligible. Each transverse component of the field now satisfies the scalar wave equation independently and it is sufficient to study the evolution of one component alone.

### 1.4.4 Modal Solutions

For structures where the refractive index is almost homogeneous in one direction (we take  $z$  as the direction of propagation of light) and only varies in the transverse directions we can speak of the modes of the structure, which can be obtained by solving (1.27)–(1.30). Modes of a system represent the eigenfunctions or eigenstates of the system. For a simple photonic device such as a waveguide, modes are the steady state, discrete solutions to the wave equation that satisfy the boundary conditions for the given refractive index distribution,  $n(x, y)$ . Modes represent the natural, equilibrium superposition of waves when light is coupled into the waveguide. On coupling light into the device, it will be guided in the form of one or more of the modes of that device. Each guided mode has characteristics such as an effective index and field distribution that are unique and do not change with time or even for different power of the incident light. Modal analysis allows us to determine the nature and behaviour of the electric and magnetic fields inside the device under CW operation.

There are several methods to find the modes of optical waveguides. These can be classified as analytical, semi-analytical and numerical. Analytical methods, as the name suggests, allow an analytical solution of the wave equation. However, such solutions are possible in rare cases (even under the weakly guiding approximation) such as step index planar waveguides. For most practical waveguides, with two-dimensional (2D) confinements, analytical solutions are not possible and some approximations have to be made. Among the semi-analytical approaches are methods such as the effective index method [34], Marcatili's method [35] and its improvement with perturbation techniques [36], the variational method [37] and the coupled-mode analysis [38].

Semi-analytical approaches generally involve solution of a differential/integral equation or an integral obtained by simplifying the wave equation. These methods work well for uniform waveguides or coupled waveguides carrying few modes and deal primarily with only the guided modes. However, when the assumption cannot be made that the structure has very few modes, or if the refractive index distribution is far too complex, then numerical methods have to be used. There is huge variety of numerical methods in photonics, some of which are scalar and a few others that can deal with both vector and scalar problems. Some examples of numerical methods include those based on the FEM, finite-difference method, method of lines (MoL), and transmission line method (TLM and  $\mu$ TLM). Some of the methods mentioned here can be used to obtain the modes of the structure as well as in situations where we are interested in the evolution of the field inside the device.

### 1.4.5 Beam Propagation Methods

In structures where the refractive index varies along the propagation direction and therefore its  $z$  dependence cannot be neglected, the modal picture may not be appropriate. An example is a tapered Semiconductor Optical Amplifier (SOA), where the field evolves along the direction of the propagation (see Figure 1.1). In such situations and many others, it is important to employ beam propagation algorithms. In these algorithms the wave equation is recast in a form

$$\frac{\partial^2}{\partial z^2} \psi = \mathbf{H} \psi \quad (1.31)$$

where  $\psi$ ,  $\mathbf{H}$  represent the electric/magnetic field and the operator containing the transverse space derivative, as well as the refractive index variation, respectively.

Beam propagation methods (BPM) are marching algorithms that through repetitive application of the same steps in sequence take the field at the input of a device, propagate it along the length and eventually yield the field at the output end [39, 40] through the solution of (1.31). The optical field in such BPM algorithms is assumed to be travelling primarily in one direction (default is the  $z$  direction), which is discretized into small intervals or steps. The field at the start of an interval is given or its functional form assumed (it may be the device input where the field from a laser is launched).

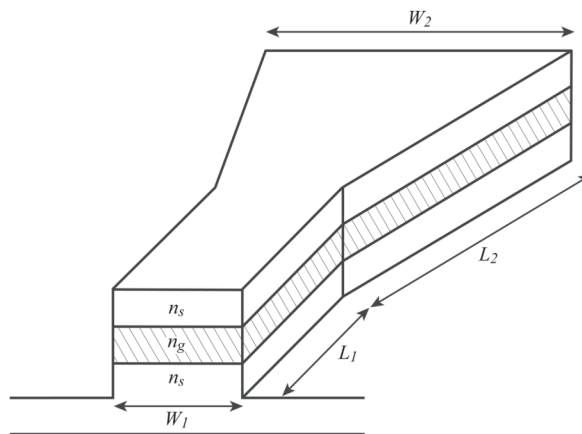

**Figure 1.1** Schematic of an etched tapered SOA structure.

The BPM algorithm then propagates the field through the interval in the  $z$  direction. The field at the end of the propagation step then acts as the input field for the next propagation step and so on. The total distance travelled along the  $z$  direction is the product of the number of propagation steps,  $n$ , and the length of each step,  $\Delta z$ . We mention a few popular methods: FFT-BPM (Fast Fourier Transform) [39, 40], FD-BPM [41–47, 49, 50], FE-BPM [48], MOL BPM [51]. The discretisation scheme employed is different in each of these methods. We will focus on basic principles of BPM here, while discussing FE-BPM in detail in Chapter 3.

Beam propagation methods can be vector in nature or scalar. Neglecting the  $\nabla(\ln \epsilon)$  term which appears inside the operator  $\mathbf{H}$ , (1.31) yields the scalar and more tractable form of the BPM equation:

$$\frac{\partial^2 \Psi}{\partial z^2} = \nabla_t^2 \Psi + k_o^2 n^2(x, y, z) \Psi(x, y, z) \quad (1.32)$$

where  $\nabla_t^2 = \frac{\partial^2}{\partial x^2} + \frac{\partial^2}{\partial y^2}$  in Cartesian coordinates and represents the transverse space derivative operator.

There are several BPM algorithms based on different numerical methods. The scalar BPM algorithms deal with the total field; that is, all the guided *and* radiation modes present in the structure. We describe in detail the FE-BPM algorithm in both scalar and vector form in Chapter 3.

We also note the particular form of (1.32), which describes waves moving in both the forward and backward directions. In principle, (1.32) can handle reflections. Therefore, BPM algorithms that solve (1.32) are termed as bi-directional methods and are very often iterative in nature. More detail of bi-directional methods can be found in some excellent references [41–44] and described in more detail in Chapter 3.

#### 1.4.5.1 Wide-Angle and Fresnel/Paraxial Approximations

The majority of BPM formulations, are uni-directional, with only the forward propagating waves taken into account. This leads to two classes of BPM methods: paraxial and wide-angle BPMs. The paraxial BPM algorithms can be derived directly by making the slowly varying envelope approximation (SVEA): the field is factored into a product of the slowly varying envelope of the field and an average phase variation over the distance travelled by the field.

$$\Psi(x, y, z) = \chi(x, y, z) \exp(-jkz) \quad (1.33)$$

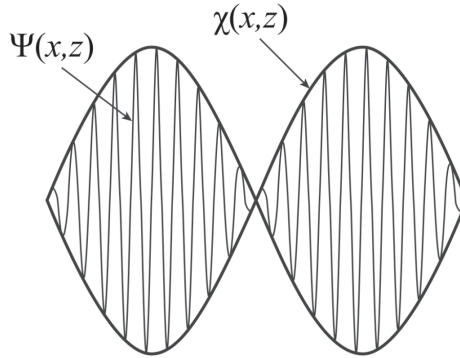

**Figure 1.2** The field  $\psi(x, z)$  and its envelope  $\chi(x, z)$  for propagation in 2D.

where  $k = k_0 n_{ref}$  with  $n_{ref}$  being a suitably chosen constant refractive index such that field varies slowly with  $z$ . This assumes that the propagation is predominantly in the  $+z$  direction. Figure 1.2 shows the fast varying field and its slowly varying envelope in 2D.

Substituting (1.33) in (1.32), we get

$$\frac{\partial^2 \chi}{\partial z^2} - 2jk \frac{\partial \chi}{\partial z} + \frac{\partial^2 \chi}{\partial x^2} + k_0^2 [n^2(x, y, z) - n_{ref}^2] \chi(x, y, z) = 0 \quad (1.34)$$

Assuming the envelope to vary slowly with respect to  $z$ , we can neglect the first term involving the second-order derivative in comparison to other terms. This is the paraxial or Fresnel approximation. When the propagation problem satisfies paraxial conditions, the above assumption simplifies the wave equation substantially and we obtain a first-order equation:

$$2jk \frac{\partial \chi}{\partial z} = \frac{\partial^2 \chi}{\partial x^2} + k_0^2 [n^2(x, z) - n_{ref}^2] \chi(x, z) \quad (1.35)$$

A further restriction is that the refractive index contrast cannot be very large for this set of techniques to be applicable for a structure. The reason is that large index contrasts will generate waves travelling at large angles with respect to the propagation direction. Indeed, in some cases even evanescent waves would be generated.

Wide-angle BPMs [45–49] have therefore been developed for structures in which the rate of variation of the refractive index is relatively large and/or there are branches in the  $z$  direction. Rewriting (1.32) in a quadratic form

and separating it into a product of two factors, one representing the forward propagating components and the other backward propagating components, leads to (1.36) and (137):

$$(\partial_z^2 - 2jk \frac{\partial}{\partial z} + \mathbf{P})\Psi = 0 \quad (1.36)$$

$$(\partial_z + j\sqrt{\mathbf{P} + k^2} + k)(\partial_z - j\sqrt{\mathbf{P} + k^2} + k)\Psi = 0 \quad (1.37)$$

where  $\mathbf{P} = \nabla_t^2 + k^2[\frac{n^2}{n_{ref}^2} - 1]$ ;  $\partial_z = \frac{\partial}{\partial z}$ .

The backward propagating term is neglected and the resulting equation

$$\frac{\partial \Psi}{\partial z} = j(\sqrt{\mathbf{P} + k^2} - k)\Psi \quad (1.38)$$

Equation (1.38) contains the square root of the propagation operator. Equation (1.38) is a paraxial-like equation since it contains only the first derivative with respect to  $z$ . However, the presence of the square root operator implies that waves propagating at large angles can be handled. Expansion of the square root operator yields wide-angle methods of different accuracy (see [45–50] for several wide-angle techniques, including but not limited to those that utilize Pade approximations to expand the square root operator). The Pade approximation of zero order results in the paraxial wave equation and is equivalent to making the Fresnel approximation.

## 1.5 Choosing a Modeling Method

Thus far, we have described some of the forms Maxwell's equations are cast into, and the attendant assumptions, applicability and nature of solutions that can be expected. We have mentioned the names of a few techniques, briefly detailing the limitations for certain classes of methods. For an appropriate modeling method for a given structure or phenomenon, we need to answer some questions:

- Is it necessary to study the evolution of the fields as a function of time?
- What is the nature of the refractive index variation in the structure (e.g., small or large)?



- Is it necessary to consider the vector nature of the fields?
- Do we need to obtain a modal solution or propagation of the fields?
- What are the required model inputs (for example, material parameters)?
- How widely can the method be applied?
- Is the light travelling in  $\pm z$  direction or in all directions?
- Is the material linear?

Based on the answers to these questions it is possible to identify the class of modeling methods that would be applicable for the problem at hand. It is possible to shortlist more than one technique that fulfills some of the listed major criteria. However, each technique has weaknesses and strengths, and other considerations that often play a part in determining the specific method of choice:

- What is the accuracy and reliability of the method?
- How stable is the method?
- What are the resources (computer time, memory) required?
- How easy is it to implement the method?

In the following section, we briefly examine the FEM against some of these criteria.

## 1.6 Finite-Element-Based Methods

We develop each aspect of the FEM-based methods in later chapters. Here, we describe in general terms the reasons why this class of methods is important and examine it against the criteria mentioned in the previous section.

The FE-based methods presented in this book are able to deal with complicated refractive index distributions, including those where the vector nature of the fields has to be considered. The  $\mathbf{H}$  field FEM that we use is highly accurate, with continuity of the fields being naturally accounted for in the implementation, unlike  $\mathbf{E}$  field-based methodologies. Modal solutions can be obtained in a vast variety of waveguide structures, ranging from simple step index to high index contrast Si slot waveguides, Bragg fibers, plasmonic structures, QCL modes, and so on. These are discussed in Chapter 2. Beam propagation solutions based on the FEM (both scalar and vector) can be applied to study power splitters, Arrayed Waveguide Gratings (AWGs), directional

couplers, polarization rotators/converters, waveguide and fiber tapers, spools, converters, nonlinear effects such as second harmonic generation (SHG), and so on, considered in Chapter 3. Furthermore, even time-dependent phenomena such as reflections, pulse propagation, and spectral response can be studied with finite-element time domain (FETD) methods, described in Chapter 4. The model parameters typically required are the refractive index distribution of the device and the dielectric function. Physical effects such as acousto-optic, thermal, electro-optic, and material non linearity can also be included in FEM analyses (see Chapter 5). Therefore, FEM-based methods can be adapted for application to a vast variety of problems.

The computational aspect of the FEM also satisfies the criteria mentioned in Section 1.5. FEM is a highly accurate method (see Chapter 2 for a detailed discussion on convergence, accuracy, stability, and resource requirement), which has been successfully tested on a variety of structures. The method is stable and highly robust and has been very successful in computer implementation including the parallel format/multithreading. The implementation of the FEM can seem challenging to a beginner, and in this book we hope to address this issue, making the method accessible, as well as explaining by way of algorithms and computer codes how to implement it easily. The resource requirement in terms of computer memory storage and run time can also be optimized especially through use of sparse matrices, for interior or closed problems. In conclusion, the FEM-based methods form a suite of highly versatile, powerful tools for modeling, and a good understanding of these is valuable for anyone interested in photonics simulation.

## References

- [1] Itoh, T. *Numerical Techniques for Microwave and Millimeter-wave Passive Structures*, New York: Wiley, 1989, 707.
- [2] Saad, S. M., "Review of Numerical Methods for the Analysis of Arbitrarily-Shaped Microwave and Optical Dielectric Waveguides," *IEEE Transactions on Microwave Theory and Techniques*, Vol. 33, No. 10, 1985, pp. 894–899.
- [3] Yevick, D., "A Guide to Electric-Field Propagation Techniques for Guided-Wave Optics," *Optical and Quantum Electronics*, Vol. 26, No. 3, 1994, pp. S185–S197.
- [4] Chiang, K. S., "Review of Numerical and Approximate Methods for the Modal-Analysis of General Optical Dielectric Wave-Guides," *Optical and Quantum Electronics*, Vol. 26, No. 3, 1994, pp. S113–S134.
- [5] Marz, R., *Integrated Optics: Design and Modeling*, Boston: Artech House, 1995.

- 
- [6] Kong, J. A., *Methods for Modeling and Simulation of Guided-wave Optoelectronic Devices*, Cambridge, MA: EMW, 1995.
- [7] Silvester, P. P., and Ferrari, R. L., *Finite Elements for Electrical Engineers*, 3rd ed, Cambridge: Cambridge University Press, 1996.
- [8] Koshiba, M., and Tsuji, Y., “Design and Modeling of Microwave Photonic Devices,” *Optical and Quantum Electronics*, Vol. 30, No. 11–12, 1998, pp. 995–1003.
- [9] Scarmozzino, R., Gopinath, A., Pregla, R., and Helfert, S., “Numerical Techniques for Modeling Guided-wave Photonic Devices,” *IEEE Journal of Selected Topics in Quantum Electronics*, Vol. 6, No. 1, 2000, pp. 150–162.
- [10] Kawano, K., and Kitoh, T., *Introduction to Optical Waveguide Analysis: Solving Maxwell’s Equation and the Schrodinger Equation*, Chichester, UK: Wiley, 2001.
- [11] Sadiku, M. N. O., *Numerical Techniques in Electromagnetics*, 2nd ed., Boca Raton, FL: CRC Press, 2001, 743.
- [12] Jin, J., *The Finite Element Method in Electromagnetics*, 2nd ed., New York: Wiley, 2002.
- [13] Jarem, J. M., and Banerjee, P. P., *Computational Methods for Electromagnetic and Optical Systems*, 2nd ed., Boca Raton, FL: CRC Press, 2011, 149, 416.
- [14] Obayya, S. *Computational Photonics*, Chichester, West Sussex, UK; Hoboken, NJ: Wiley, 2011.
- [15] Yamashita, E., and Mittra, R., “Variational Method for the Analysis of Microstriplines,” *Transactions on Microwave Theory and Techniques*, Vol. MTT-16, 1968, pp. 251–256.
- [16] Yamashita, E., *Analysis Methods for Electromagnetic Wave Problems*, Boston; London: Artech House, 1996.
- [17] Harrington, R., *Field Computation by Moment Methods*, New York: Macmillan, 1968.
- [18] Ney, M., “Method of Moments as Applied to Electromagnetic Problems,” *IEEE Transactions on Microwave Theory and Techniques*, Vol. 33, No. 10, 1985, pp. 972–980.
- [19] Stamnes, K., Tsay, S. C., Wiscombe, W., and Jayaweera, K., “Numerically Stable Algorithm for Discrete-Ordinate-Method Radiative-Transfer in Multiple-Scattering and Emitting Layered Media,” *Applied Optics*, Vol. 27, No. 12, 1988, pp. 2502–2509.
- [20] Rahman, B. M. A., and Davies, J. B., “Finite Element Analysis of Optical and Microwave Waveguide Problems,” *IEEE Transactions on Microwave Theory Techniques*, Vol. MTT-32, 1984, pp. 20–28.
- [21] Koshiba M., *Optical Waveguide Theory by the Finite Element Method*, Tokyo, London: KTK Scientific; Dordrecht; Kluwer Academic, 1992.
- [22] Mur, G., “Finite Difference Method for the Solution of Electromagnetic Waveguide Discontinuity Problem,” *IEEE Transactions on Microwave Theory Techniques*, Vol. MTT-22, 1974, pp. 54–57.
- [23] Yamauchi, J., *Propagating Beam Analysis of Optical Waveguides (Optoelectronics & Microwaves)*, New York: Wiley-Blackwell, 2001.

- [24] Hoefler, W., "The Transmission-Line Matrix-Method—Theory and Applications," *IEEE Transactions on Microwave Theory and Techniques*, Vol. 33, No. 10, 1985, pp. 882–893.
- [25] Christopoulos, C., *The Transmission-Line Modeling Method*, TLM, Wiley-IEEE PRESS, 1995.
- [26] Pregla, R., Koch, M., and Pascher, W., "Analysis of Hybrid Waveguide Structures Consisting of Microstrips and Dielectric Waveguides," Proceedings of the 17th European Microwave Conference, 1987, pp. 927–932.
- [27] Sadiku, M. N. O., *Monte Carlo Methods for Electromagnetics*, Boca Raton, FL: CRC Press, 2009.
- [28] Hadley, G. R., "Transparent Boundary-Condition for the Beam Propagation Method," *IEEE Journal of Quantum Electronics*, Vol. 28, No. 1, 1992, pp. 363–370.
- [29] Hadley, G. R., "Transparent Boundary-Condition for Beam Propagation," *Optics Letters*, Vol. 16, No. 9, 1991, pp. 624–626.
- [30] Bérenger, J. P., "A Perfectly Matched Layer for the Absorption of Electromagnetic Waves," *Journal of Computational Physics*, Vol. 114, No. 2, 1994, pp. 185–200.
- [31] Bérenger, J., *Perfectly Matched Layer (PML) for Computational Electromagnetics*, 1st ed., San Rafael, CA: Morgan & Claypool Publishers, 2007.
- [32] Engquist, B., and Majda, A., "Absorbing Boundary-Conditions for Numerical-Simulation of Waves," *Mathematics of Computation*, Vol. 31, No. 139, 1977, pp. 629–651.
- [33] Ramahi, O. M., "Complementary Operators—A Method to Annihilate Artificial Reflections Arising from the Truncation of the Computational Domain in the Solution of Partial-Differential Equations," *IEEE Transactions on Antennas and Propagation*, Vol. 43, No. 7, 1995, pp. 697–704.
- [34] Tamir, T., *Integrated Optics*, Berlin; New York: Springer, 1975.
- [35] Marcatili, E. A., "Dielectric Rectangular Waveguide and Directional Coupler for Integrated Optics," *Bell Systems Technical Journal*, Vol. 48, 1969, pp. 2071–2102.
- [36] Kumar, A., Thyagarajan, K., and Ghatak, A. K., "Analysis of Rectangular-core Dielectric Waveguides—An Accurate Perturbation Approach," *Optics Letters*, Vol. 8, No. 1, 1983, pp. 63–65.
- [37] Cairo, L., *Variational Techniques in Electromagnetism*, London: Blackie, 1965.
- [38] Hardy, A., and Streifer, W., "Coupled Mode Theory of Parallel Wave-Guides," *Journal of Lightwave Technology*, Vol. 3, No. 5, 1985, pp. 1135–1146.
- [39] Feit, M. D., and Fleck, J. A., "Light-Propagation in Graded-Index Optical Fibers," *Applied Optics*, Vol. 17, No. 24, 1978, pp. 3990–3998.
- [40] Feit, M. D., and Fleck, J. A., "Computation of Mode Properties in Optical Fiber Wave-Guides by a Propagating Beam Method," *Applied Optics*, Vol. 19, No. 7, 1980, pp. 1154–1164.

- 
- [41] Kaczmariski, P., and Lagasse, P. E., "Bidirectional Beam Propagation Method," *Electronics Letters*, Vol. 24, No. 11, 1988, pp. 675–676.
- [42] El-Refaei, H., Yevick, D., and Betty, I., "Stable and Noniterative Bidirectional Beam Propagation Method," *IEEE Photonics Technology Letters*, Vol. 12, No. 4, 2000, pp. 389–391.
- [43] Lu, Y. Y., and Wei, S. H., "A New Iterative Bidirectional Beam Propagation Method," *IEEE Photonics Technology Letters*, Vol. 14, No. 11, 2002, pp. 1533–1535.
- [44] Rao, H. L., Scarmozzino, R., and Osgood, R. M., "A Bidirectional Beam Propagation Method for Multiple Dielectric Interfaces," *IEEE Photonics Technology Letters*, Vol. 11, No. 7, 1999, pp. 830–832.
- [45] Hadley, G., "Wide-Angle Beam Propagation Using Pade Approximant Operators," *Optics Letters*, Vol. 17, No. 20, 1992, pp. 1426–1428.
- [46] Hadley, G. R., "Multistep Method for Wide-Angle Beam Propagation," *Optics Letters*, Vol. 17, No. 24, 1992, pp. 1743–1745.
- [47] Huang, W. P., and Xu, C. L., "A Wide-Angle Vector Beam Propagation Method," *IEEE Photonics Technology Letters*, Vol. 4, No. 10, 1992, pp. 1118–1120.
- [48] Koshiba, M., and Tsuji, Y., "A Wide-angle Finite-element Beam Propagation Method," *IEEE Photonics Technology Letters*, Vol. 8, No. 9, 1996, pp. 1208–1210.
- [49] Yevick, D., and Hermansson, B., "Convergence Properties of Wide-angle Techniques," *IEEE Photonics Technology Letters*, Vol. 6, No. 12, 1994, pp. 1457–1459.
- [50] Lu, Y. Y., and Ho, P. L., "Beam Propagation Method Using a [(p-1)/p] Pade Approximant of the Propagator," *Optics Letters*, Vol. 27, No. 9, 2002, pp. 683–685.
- [51] Gerdes, J., and Pregla, R., "Beam-propagation Algorithm Based on the Method of Lines," *Journal of the Optical Society of America*, Vol. 8, No. 2, 1991, pp. 389–394.

