



## City Research Online

### City, University of London Institutional Repository

---

**Citation:** Dhand, A. & Pullen, K. R. (2013). Review of Flywheel based Internal Combustion Engine Hybrid Vehicles. *International Journal of Automotive Technology*, 14(5), pp. 797-804. doi: 10.1007/s12239-013-0088-x

This is the unspecified version of the paper.

This version of the publication may differ from the final published version.

---

**Permanent repository link:** <https://openaccess.city.ac.uk/id/eprint/2789/>

**Link to published version:** <https://doi.org/10.1007/s12239-013-0088-x>

**Copyright:** City Research Online aims to make research outputs of City, University of London available to a wider audience. Copyright and Moral Rights remain with the author(s) and/or copyright holders. URLs from City Research Online may be freely distributed and linked to.

**Reuse:** Copies of full items can be used for personal research or study, educational, or not-for-profit purposes without prior permission or charge. Provided that the authors, title and full bibliographic details are credited, a hyperlink and/or URL is given for the original metadata page and the content is not changed in any way.

---

---

---

City Research Online:

<http://openaccess.city.ac.uk/>

[publications@city.ac.uk](mailto:publications@city.ac.uk)

---

# Review of Flywheel based Internal Combustion Engine Hybrid Vehicles

Aditya Dhand, Keith Pullen  
School of Engineering and Mathematical Sciences  
City University London  
London EC1V 0HB, UK  
Email: [aditya.dhand.1@city.ac.uk](mailto:aditya.dhand.1@city.ac.uk)

## Abstract

Hybrid vehicles of different configurations and utilizing different energy storage systems have existed in development for many decades and more recently in limited production. They can be grouped as parallel, series or complex hybrids. Another classification is micro, mild and full hybrids which makes the distinction on the basis of functionality. The common energy storage systems in hybrid vehicles are batteries, supercapacitors and high speed flywheels. This paper aims to review a specific type of hybrid vehicle which involves the internal combustion engine (ICE) as the prime mover and the high speed flywheel as an energy storage device. Such hybrids are now attracting considerable interest given their potential for low cost. It is hence timely to produce a review of research and development in this subject. The flywheel is coupled to the drive line with a continuous variable transmission (CVT). The CVT can be of various types such as electrical, hydraulic or mechanical but usually in this case it is a non-electrical one. Different configurations are possible and the paper provides a timeline of the development of such powertrains with various examples. These types of hybrid vehicles have existed as prototypes for many decades and the authors believe that their development has reached levels where they can be considered serious contenders for production vehicles.

**Keywords:** Flywheel, Continuous variable transmission, Hybrid vehicle, Internal combustion engine

## Introduction

Hybrid vehicles (HV) are defined as vehicles where there are at least two different sources of energy present. On the same lines a hybrid electric vehicle (HEV) is just one type of HV where one of the sources is electric. Although in current times, the terms HV and the HEV are used interchangeably since HEVs are the prevalent HVs in the market, there are other types of HVs which have been researched over the years and one of them is a mechanical flywheel based HV. Unlike battery electric vehicles (BEV) which by virtue of having a motor-generator (MG) and a battery have the inherent capability to recover brake energy, though not very efficiently, the conventional internal combustion engine vehicle (ICEV) does not have that luxury. For the ICEV this is only possible by the addition of a secondary energy storage device. The flywheel energy storage system (FESS) is an ideal secondary storage technology for the conventional ICEV since it is able to store the energy in the form that it was recovered i.e. mechanical kinetic energy. By utilizing the FESS, the energy lost in conversion from one form to the other is saved. The FESS can be classified as low speed and high speed systems or subcritical and supercritical systems depending on their maximum speed [1]. The concept is not new and flywheel internal combustion engine hybrid vehicles (FWICEHV) have been researched for many years. This paper reviews the history and current status for FWICEHV powertrains. It emphasises on the typical layouts of the powertrain and the transmissions used to connect the FESS to the driveline.

The FWICEHV has a layout which is similar to the HEV. The difference is that the instead of the battery, the energy is stored in a flywheel (FW) and instead of the electrical transmission using MGs, a mechanical continuously variable transmission (CVT) is used. Although there are few studies in which an electrical transmission was used in a FWICEHV [2], the overwhelming majority use

mechanical or hydraulic CVTs, as using the electrical transmission can detract from the benefits of having the FW, except in a few particular circumstances. Also the combination of mechanical transmission and FESS is more cost effective than the combination of a battery and MGs. The CVTs were used in different combinations such as in power split (PS) design to suit the application.

**Parallel hybrids:** Fig. 1-3 shows the typical layouts of a parallel hybrid used in FW based vehicles. In the first layout the ICE and the FW are connected upstream of the transmission which is a CVT. Both the flywheel and the ICE have clutches so that they can be decoupled from the driveline as required. The flywheel may have reduction gear to lower the output speed due to certain design constraints. The advantage of such a system is that it allows the option of ICE to be operated at its optimum efficiency to charge the flywheel and then the flywheel could take over the motoring of the vehicle. However the disadvantages are that the system would require complex controls, and the speeds of the ICE and FW are coupled to each other. Another variation of such a layout is shown in fig. 2. In this case the CVT is directly coupled to the flywheel and both the FW and the ICE are connected upstream of the conventional transmission. The FW speed can be controlled by CVT separately from the ICE however there would be the cost of the extra transmission. In another case, figure 3, the FW with CVT can be connected downstream of the transmission. In this case it is easier to integrate the system on an existing conventional system. Regenerative braking is possible but load point shifting might not be straightforward.

**Series hybrids:** This layout, shown in fig. 4 is used less commonly in FWICEHV. In this case usually a larger flywheel is used and the ICE is connected to flywheel by a CVT. Further the FESS is also connected to the driveshaft by another CVT. The disadvantage of such a layout would be that it would require a much bigger flywheel thereby the safety aspect would become all the more critical. It would be seen in the next section that almost all developments of FWICEHV were based on parallel layouts.

In the next section, a timeline of FWICEHVs is presented where most of the concepts developed are based on any one of the previously mentioned layouts.

## History and applications

Flywheels have been used in vehicular applications for many years. One of the first major applications was their use in the so called Gyrobus by Oerlikon in Switzerland in the 1950s [3]. Fig. 5 shows the bus. This was a specially designed 35 seater bus which used a 1500 kg, 1.6 m diameter and 32 MJ FW as the sole energy source. The transmission was electrical. The FESS would be charged at the recharging stations placed along the route using 360 V, 50 Hz AC supply. The bus could run for an average distance of about 1.2 km on one single charge. This bus ran in cities in Europe and Africa for 16 years before it was discontinued in 1969. Few of the drawbacks of this bus included its incapability to be used on gradients, complex operation required by the driver and the fact that it had to be charged frequently.

Probably the first FWICEHV powertrain in road applications was the Gyreacta and Hydreacta transmissions developed by Clerk in 1964 in England to be used in a bus and car application respectively [4]. It consisted of a hybrid drive using flywheel and an ICE. The transmission consisted of differentiating and integrating epicyclic gear sets to connect the steel flywheel to the wheels. Fig. 6 shows the transmission. It used the planetary gearset (PGS) as a two degree of freedom device. There were multiple PGSs which were actuated via a clutch. The Hydreacta was a hydromechanical transmission which combined the Gyreacta with parallel geared idling and hydrokinetic datum coupling into the primary epicyclics. In Gyreacta transmission there were stepped datum shifts and there was flywheel speed loss for each shift. The hydromechanical transmission was inefficient but smooth whereas the pure mechanical was efficient but stepped. The system was complex and costly though it was the first of its kind.

In 1969 Rabenhorst designed the superflywheel using high uniaxial tensile strength material which had the specific energy 66 Wh/kg [5]. This was to rekindle the interest in FESS since using such composite material significant amount of energy could be stored in the FESS. In 1970 Lockheed Missiles and Space Company produced a report under contract from Environmental Protection Agency (EPA) of the US which explored the feasibility of flywheel. In 1971 Lawson presented the FWICEHV concept which is shown in fig. 7 [6]. The concept was a parallel hybrid in which both the flywheel and ICE could drive the vehicle. Different flywheel shapes and materials were discussed. The flywheel selected was for a family car application with a storage capacity of 0.5 kWh. The flywheel was designed and tested and it was concluded that FW is suitable for an urban hybrid vehicle. The transmission is not discussed, so it cannot be commented on by the review authors.

In 1971 Dugger et. al. showed the potential application of the super flywheel in a FWICEHV [7]. The author discusses options for four classes of vehicles: commuter car, family car, city bus and van. It is suggested that the most suitable CVT is the hydromechanical one due to its high efficiency and controllability. The drivetrain schematic from their studies is shown in fig. 8. The ICE is run in on-off mode and a clutch connects it to the driveline. The FW is also connected via a reduction gear and clutch to the driveline. The Flywheel is used to power the vehicle till its speed is reduced to half the maximum speed and then the ICE turns on to recharge the flywheel. The gearbox also provides a power take off (PTO) for the accessories and there is an electrical flywheel charge unit with which there is possibility of charging the FW externally. The gear box is connected to a CVT which connects to the drive shaft. It suggests that the operator controls are expected to be similar to conventional vehicles. They conclude that the propulsion system is promising on all the four classes of vehicles studied. The review authors consider achieving an affordable control system of this type with the technology of the time would have been a major challenge.

In the late 1970s and early 1980s, Frank and Beachley of the University of Wisconsin-Madison worked on a FWICEHV [8]. The powertrain used a Ford Pinto 2.3 litre ICE with electronic fuel injection

and the CVT was a power split hydrostatic CVT as shown in the fig. 9. It was a parallel hybrid system. Their main objectives were to operate the ICE at minimum brake specific fuel consumption (BSFC), remove ICE idling and recover braking energy. They considered three different CVT configurations before deciding on the hydromechanical one. The first one was using a slipping clutch with a multi ratio discrete gearbox having 12 ratios. The advantage of using a large number of ratios was that the efficiency improved, though such a system would require excessive shifting by the operator. The other two configurations examined were using PS-CVT with either the hydrostatic or the v-belt variator. A predicted mileage improvement of 58% was achieved on the EPA city driving cycle. It is noted that the principle of a stepped gearbox and slipping clutches has been further investigated by Read [9] and automatic control of such a system at affordable cost is now possible.

In 1976 Loscutoff proposed a series HV with a large FW and a small ICE as shown in fig 10 [10]. The power of the ICE is proposed to be 7.5 kW and the FW is sized to be 10 kWh. The connections between the FW and ICE as well as between the FW and the drive shaft were CVTs. In this design the ICE will be operated in its efficient region and its main function is to continuously charge the FW during transit as well as during vehicle stops. If the FW is full charged the ICE can be stopped and the FW will solely power the vehicle till its speed reaches the lower limit when the ICE will be restarted. Once the FW is fully discharged the ICE will provide motive power to drive the vehicle though its performance would be reduced. However the disadvantages of putting such a large FW would be increased safety problems in case of failure due to the high energy content and large gyroscopic forces. The type of CVT is not discussed.

In 1981 Hagin et. al. presented the FW assisted "Gyrobuss" being developed by MAN Germany [11]. The hybrid drive of the bus consisted of a diesel ICE with an IVT and FESS. The diesel engine was 100 kW which was much less than that used in the conventional bus. The FW, having energy capacity of 750 Wh, is connected to a PGS reduction gear and then connected to hydromechanical IVT which had two modes; hydrostatic and hydromechanical. The first driving range is up to 20% of the output speed and the second one is a power split hydromechanical which has high efficiency of up to 91%. The bus reportedly achieved savings of up to 16 % but it was noisy due to the swashplate hydraulic units and had poor efficiency in the low speed range. The fig. 11 below shows a schematic of the flywheel and transmission for the bus.

It can be noted that most of the concepts discussed uptill now utilized a hydromechanical transmission. This transmission was popular in the in the 1970s due to their commercial availability [12]. However their part load efficiency was poor and they tended to be noisy. The trend shifts with the application of the traction type CVTs such as the v-belt and toroidal type in the following examples.

In 1986 Greenwood showed the concept of a FW assisted ICE bus using the Perbury CVT transmission [13]. The Perbury transmission was a double cavity toroidal transmission and used in the

power recirculating mode. The disadvantage of the power recirculating design is the drop in efficiency and higher loading of the transmission, however it leads to a wider speed ratio range. The fig 12. shows the powertrain concept. The diesel engine and the FW are both connected upstream of the CVT. There is a sprag clutch which connects the ICE to the driveline and permits power to flow only from the engine. The FW is connected to the driveline by a multi plate clutch and can also be disconnected via a disconnect clutch. The operation of the powertrain is explained but no results are presented. It should be noted that the early work was foundational leading to the establishment of Torotrak which is a manufacturer highly active in the field of CVTs.

In 1986 Schilke et. al. presented a FWICEHV design by General Motors [14]. The FW was connected in parallel to the ICE using a v-belt CVT. There were two variants studied. One was called a two-mode system and the other was a single mode system. Fig 13 shows the two mode system. The two-mode hybrid configuration had a high speed flywheel which could provide acceleration assist up to 100 kph. In order to obtain the flywheel power for such a long range of the vehicle speed the CVT was traversed twice which provided the two modes and also avoids power recirculation. Further there was a low speed mode where the FW was declutched and the ICE powers the vehicle as well as the FW charging mode. The FW could be charged by the ICE or the vehicle or both. The ICE was run at its best efficiency point intermittently and when the FW was charged the ICE was switched off and the FW powered the vehicle. During the tests it turned out that the system was complex and the parasitic losses were high and the single mode was chosen where the power passed through the CVT only once. In this schematic the ICE would not charge the FW and also the ICE was not always run at its best region. The system was analysed, designed and tested. The system was predicted to produce a fuel economy benefit of 13% on the EPA cycle which was deemed too small to justify the associated costs and the research was abandoned. Fig. 14 shows the schematic of the system.

In 1987 van der Graaf from the University Eindhoven presented a two mode FWICEHV similar to the GM concept [15]. The system consisted of a 1.4 L 47 kW ICE, a v-belt CVT, synchromesh clutches and a flywheel module. The system was predicted to achieve savings of 15-25% in city traffic. A more optimized version of the same design was presented by Kok in 1999 [16]. According to the author the savings from such a system are much dependent on the parasitic losses of the driveline. On a test rig fuel consumption reduction of 30% is reported when the ICE is doing stop-start with a FW system. Also the author suggests that the savings are predominantly due to the more efficient operation of the engine rather than due to regenerative braking. This conclusion is also considered to be very important by the review authors. Fig. 15 shows the system.

In the systems that have been described till now the main idea was to utilize the FW as an energy storage device as part of a hybrid vehicle. In 2001 a so called zero inertia powertrain was developed at University Eindhoven in which the main aim was to avoid the inertia effect of the engine which had a tendency to drag the vehicle when accelerating with a CVT thereby improving the driveability of the system [17]. The fig. 16 shows the zero inertia powertrain. In conventional vehicles the CVT is used to allow the ICE to run at its best efficiency point. During fast accelerations the only way for the ICE to increase its power would be to increase its speed. During that process the ICE inertia would drag it down in order to increase its own speed. With a FW providing power assist this situation was avoided

and this illustrates an important attribute of an energy storage flywheel from the review authors' perspective.

In 2008 Diego-Ayala et. al. from Imperial College designed a FW assisted powertrain in which the FW was connected to the CVT which was coupled downstream of the conventional gearbox in the driveline [18]. Unlike some of the previous cases the FW in this case was independently connected to the driveshaft. The author utilized the PGS as a two degree of freedom device in the form of a CVT by using a brake at one of the branches of the PGS to control the FW speed. The brake only system is simple and achieves small FE savings due to its limited range. Another embodiment is shown in which a v-belt variator is added to the system to increase its range, however the control strategy is set to avoid power recirculation. Fig. 17 shows both the systems. The system is used to recuperate brake energy which is supplied back during the acceleration during which the ICE is switched off. According to the author the improvement in FE with the system is more due to the less frequent ICE operation rather than the engine operating at its most efficient range. FE improvements of up to 22% and 33% for a car and bus respectively are reported as compared to conventional vehicles. According to the review authors, the advantage of such a system is that it can be add on to a conventional system; however the FW cannot be charged up during vehicle stops.

Since 2009 the Formula 1 has introduced limited kinetic energy recovery system (KERS) in its race cars. Most of KERS are electrical in nature but Flybrid-Torotrak system employs a mechanical flywheel based KERS [19]. In this system the flywheel is connected to a double toroidal drive which is connected to the input drive. Fig. 18 shows a schematic of the system.

Currently various efforts are underway to implement such systems in road vehicles. Projects such as "Flybus" [20] and "KinerStor" [21] are being undertaken in the UK by Ricardo to implement FESS with mechanical CVTs in road vehicles in collaboration with OEMs. Another group of British companies are working on Flywheel Hybrid System for Premium Vehicles (FHSPV) programme to apply the system in a Jaguar [22]. Other companies such as Volvo are doing similar developments [23].

Another example of the FWICEHV being developed by a consortium in the Netherlands is the so called "MecHybrid" [24, 25]. This type of the configuration is similar to fig. 1. According to the authors the system is a low cost solution offering fuel savings by engine shut down during vehicle standstill, regenerative braking and flywheel only driving. The flywheel is of low energy capacity and there is discrete shifting between the various driving modes by use of clutches. The advantages and disadvantages of such a system are as discussed in the parallel hybrid section. The concept allows the ICE to operate at most efficient points by FW charging or FW only driving mode, though it requires complex controls and energy management. The high frequency shifting between modes needs to be avoided to maintain driveability. The fuel economy improvement is also limited by the smaller size of flywheel.

Another recent concept is presented by Igor Trivić [26]. In his concept the FW is connected to a v-belt CVT coupled to the input shaft of an automated manual transmission (AMT). The other end of the AMT input shaft is connected to ICE with a clutch. With this method the ratio range of the transmission is increased by appropriate gear shifting of the AMT. The system requires precise control in order to shift to the appropriate gear as the v-belt CVT approaches its limit and in view of the review authors this is a major challenge with this type of CVT. The layout offers the possibility of brake recuperation as well as ICE load point shifting. Fig 19 shows the layout.



## Conclusions

Different types of hybrid vehicles exist today which may be classified in accordance to their powertrain layout, type of energy storage device employed and level of hybrid functionality achieved. This paper deals with hybrid vehicles which have IC engine providing main motive power and flywheel acting as the energy storage. The paper shows the history of mechanical flywheel based internal combustion engine hybrid vehicles and reviews the various powertrain concepts in this field. The interest in FWs has been there since many decades and various organisations and researchers have presented different designs. With the recent accelerated effort, it can be said that the development of FWs has reached a point when their implementation may soon be a reality in mass produced road vehicles.

## References

1. Hofman, T. et. al., Optimal design of energy storage systems for hybrid vehicle drivetrains, IEEE Vehicle Power and Propulsion Conference, 2005
2. Study of heat engine/flywheel: hybrid propulsion configuration with electrical transmission system. AiResearch Manufacturing Company of California, United States Dept. of Energy. Division of Transportation Energy Conservation, Washington, DC 1978
3. The Oerlikon Electrogyro, Its development and application for Omnibus service. Automobile Engineer (December 1955)
4. Clerk, R., The Utilization of Flywheel Energy, SAE paper 640047
5. Rabenhorst, D.W., Primary Energy Storage and the Superflywheel" APL/JHU Report TG-1081, 1969
6. Lawson, L., Design and testing of high energy density flywheels for application to flywheel/heat engine hybrid vehicle drives, Intersociety Energy Conversion Engineering Conference 1971
7. Dugger, G. et. al., Flywheel and flywheel/heat engine hybrid propulsion systems for low-emission vehicles, Intersociety Energy Conversion Engineering Conference 1971
8. Frank, A., and Beachley, N., Improved fuel economy in automobiles by use of a flywheel energy management system, Flywheel Technology Symposium 1975
9. Read, M., Flywheel Energy Storage Systems for Rail, PhD Thesis, Imperial College London, 2010
10. Loscutoff, W., Flywheel/Heat Engine Power for an Energy-economic personal vehicle, Prepared for the Energy Research and Development Administration under Contract E(45-1): 1830, 1976
11. Hagin, F. et. al., Use of hydrostatic braking and flywheels systems in buses (hydrobus and gyrobus) - their future applications in hybrid electric vehicle to reduce energy consumption, and to increase range and performance, Electric Vehicle Development Group 4th International Conference: Hybrid, Dual Mode and Tracked Systems, 1981
12. Burrows, C.R. et. al., An Assessment of Flywheel Energy Storage in Electric Vehicles, SAE paper 800885
13. Greenwood, C., Integration of a commercial vehicle regenerative braking driveline, International Conference on Integrated Engine Transmission Systems, 1986
14. Schilke, N. et. al., The design of an engine-flywheel hybrid drive system for a passenger car, Proceedings of the Institution of Mechanical Engineers, Part D: Journal of Automobile Engineering, Vol. 200, 1986
15. Van der Graaf, R., An IC engine flywheel hybrid drive for road vehicles, EAEC Conference 1987

16. Kok, D., Design optimisation of a flywheel hybrid vehicle, PhD Thesis, Technical University Eindhoven, 1999
17. Shen, S. et. al., Coordinated control of a mechanical hybrid driveline with a continuously variable transmission, JSAE Review 22 (4), 453–461, 2001
18. Diego-Ayala, U. et. al., "The mechanical hybrid vehicle: an investigation of a flywheel-based vehicular regenerative energy capture system," Proceedings of the Institution of Mechanical Engineers, Part D: Journal of Automobile Engineering, vol. 222, Nov. 2008, pp. 1903-1917.
19. Brockbank, C. and Greenwood, C., Full-Toroidal Variable Drive Transmission Systems in Mechanical Hybrid Systems – From Formula 1 to Road Vehicles Formula 1, International CTI Symposium "Innovative Automotive Transmissions" Berlin, 2008
20. Flybus to start testing first flywheel hybrid bus, Press release issued by Flybus project, 2011, [www.ricardo.com](http://www.ricardo.com)
21. KinerStor project aims to demonstrate viability of low cost flywheel hybrid systems, Press release, 2009, [www.ricardo.com](http://www.ricardo.com)
22. Technology Strategy Board research project targets 20% cut in CO2 emissions using flywheel-CVT system, FHSPV Press Release, 2010, [www.flybridsystems.com](http://www.flybridsystems.com)
23. Birch, S., Volvo spins up flywheel technology research, Automotive Engineering International Online, June, 2011
24. Vroemen, B. et. al., Mechybrid; a low-cost mechanical hybrid," in Proceedings of the 6th International Conference on Continuously Variable and Hybrid Transmissions, Maastricht, Netherlands, 2010
25. Berkel, K. van et. al., Optimal Energy Management for a Flywheel-Based Hybrid Vehicle, 2011 American Control Conference, San Francisco, CA, USA June 29 - July 01, 2011
26. Trivić, I., Comparative Analysis of Alternative Hybrid Systems for Automotive Applications, Doctorate Thesis, University of Bologna, 2012

Figures

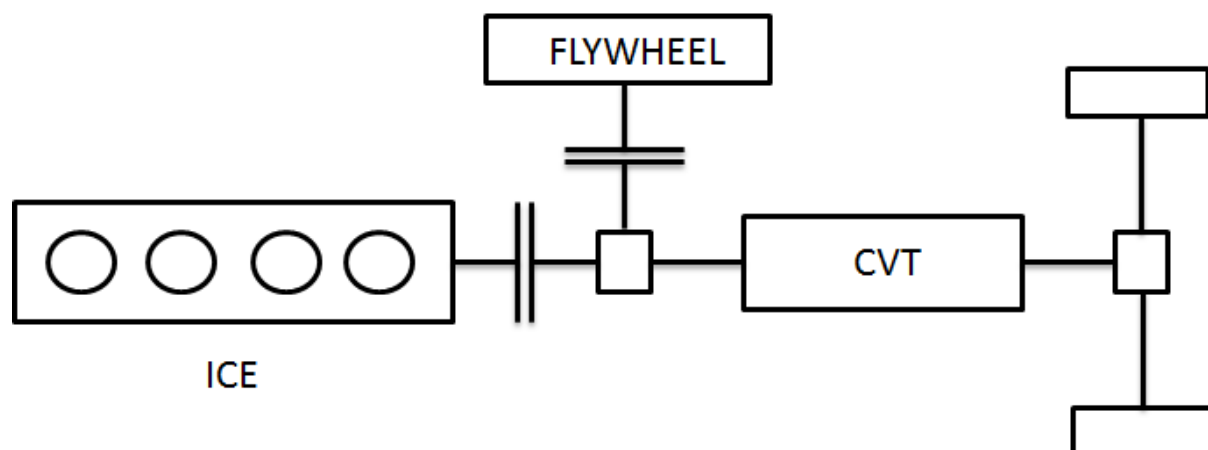

Figure 1 Parallel Layout 1

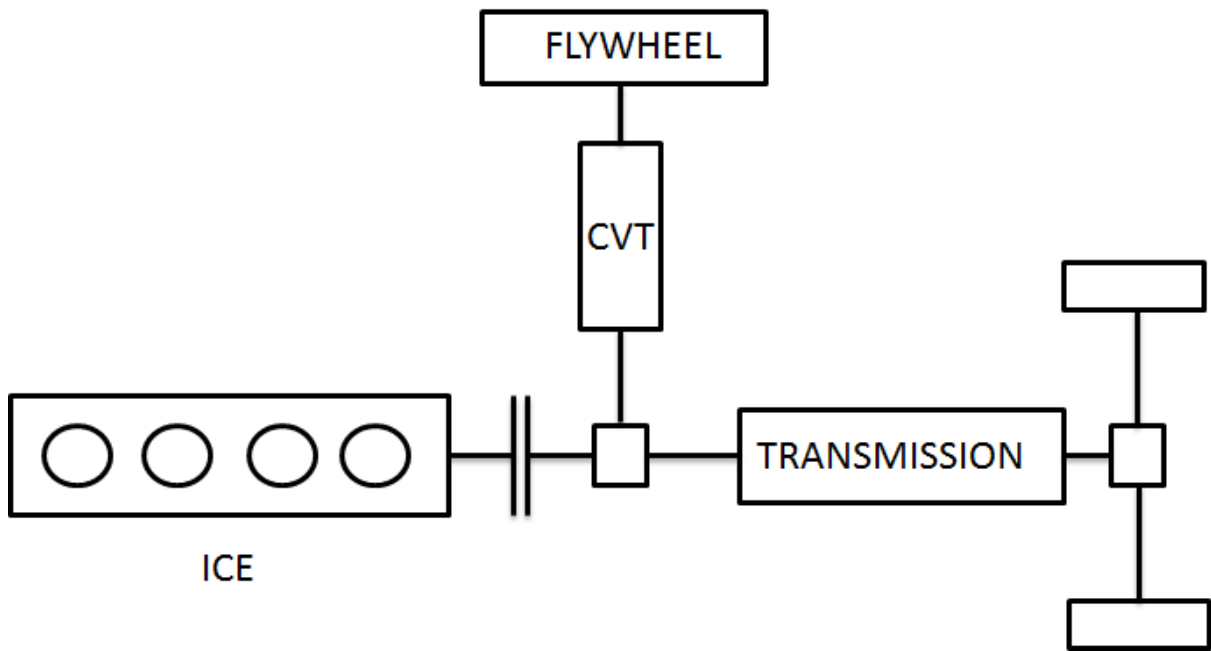

Figure 2 Parallel Layout 2

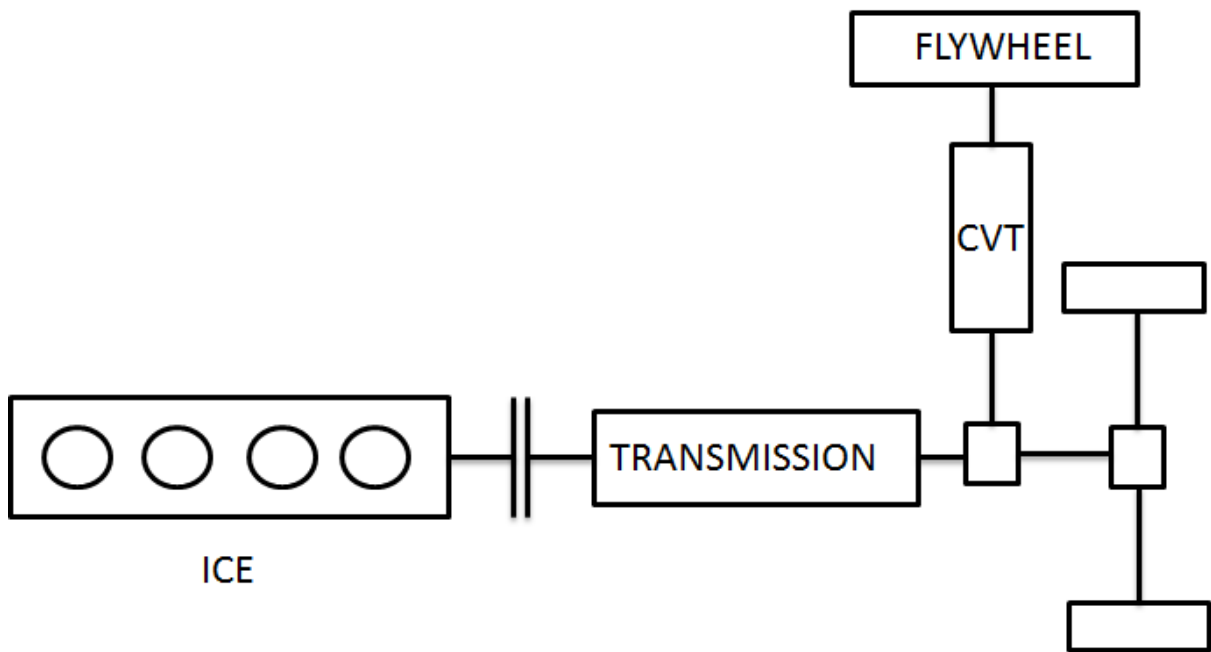

Figure 3 Parallel Layout 3

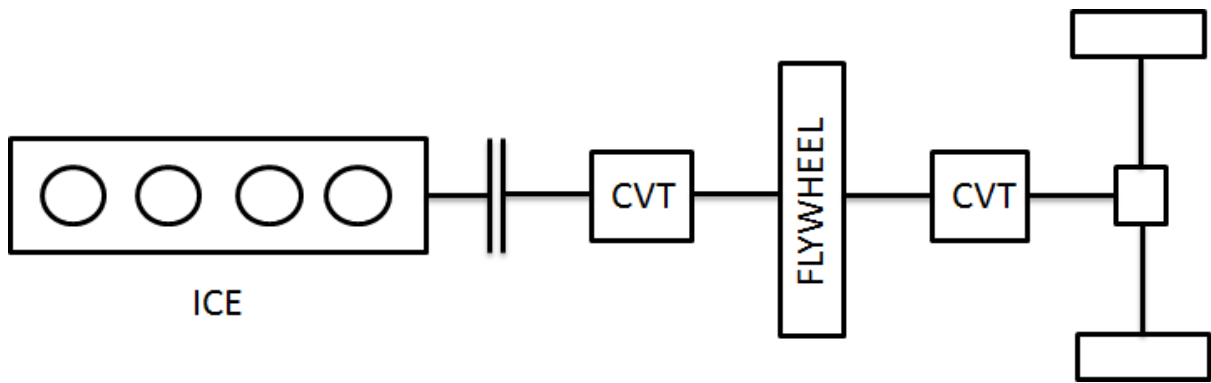

Figure 4 Series Layout

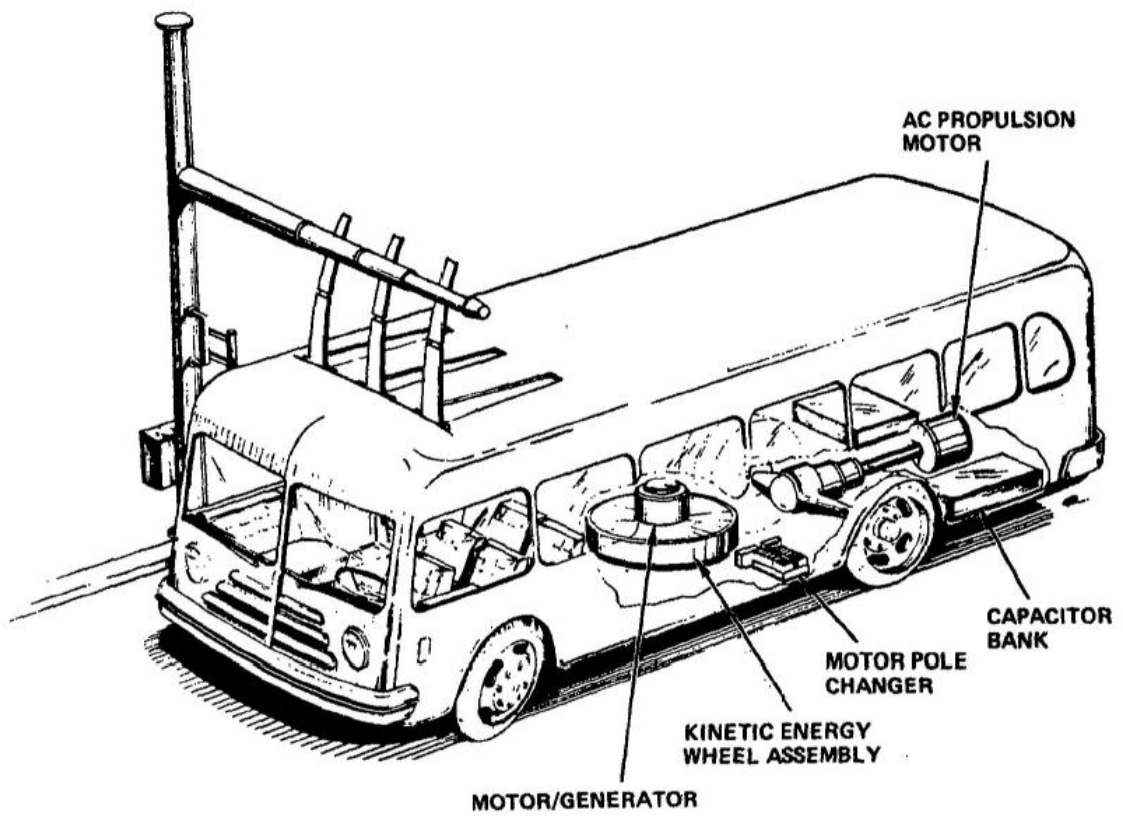

Figure 5 Oerlikon Bus

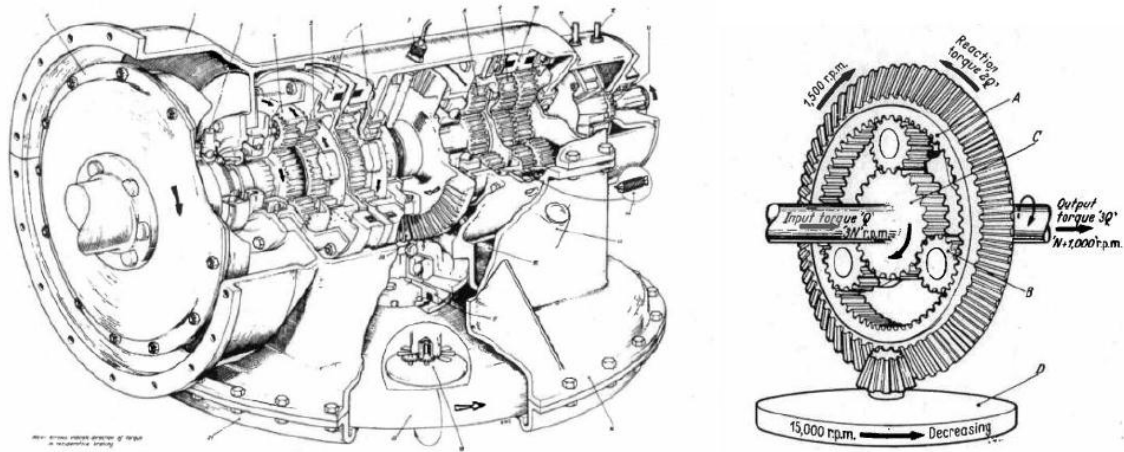

Figure 6 Gyreacta Transmission

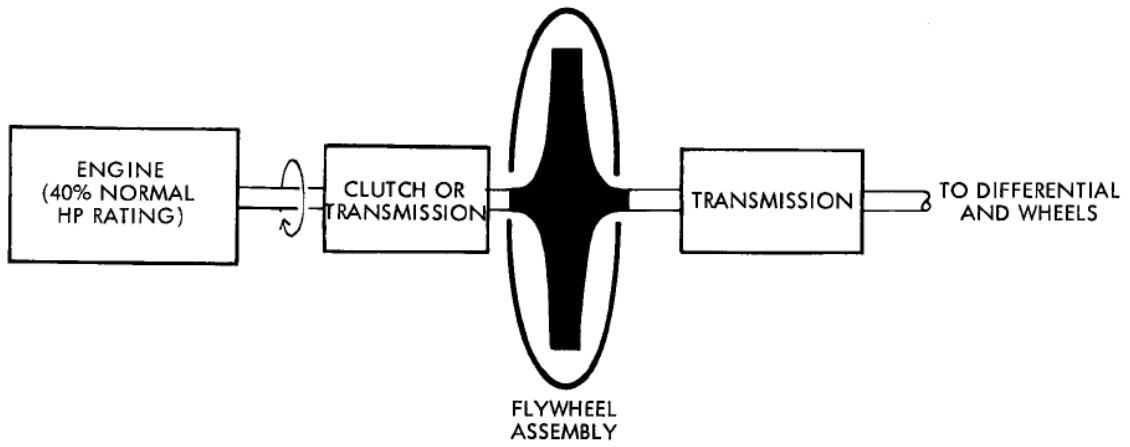

Figure 7 Lockheed Concept

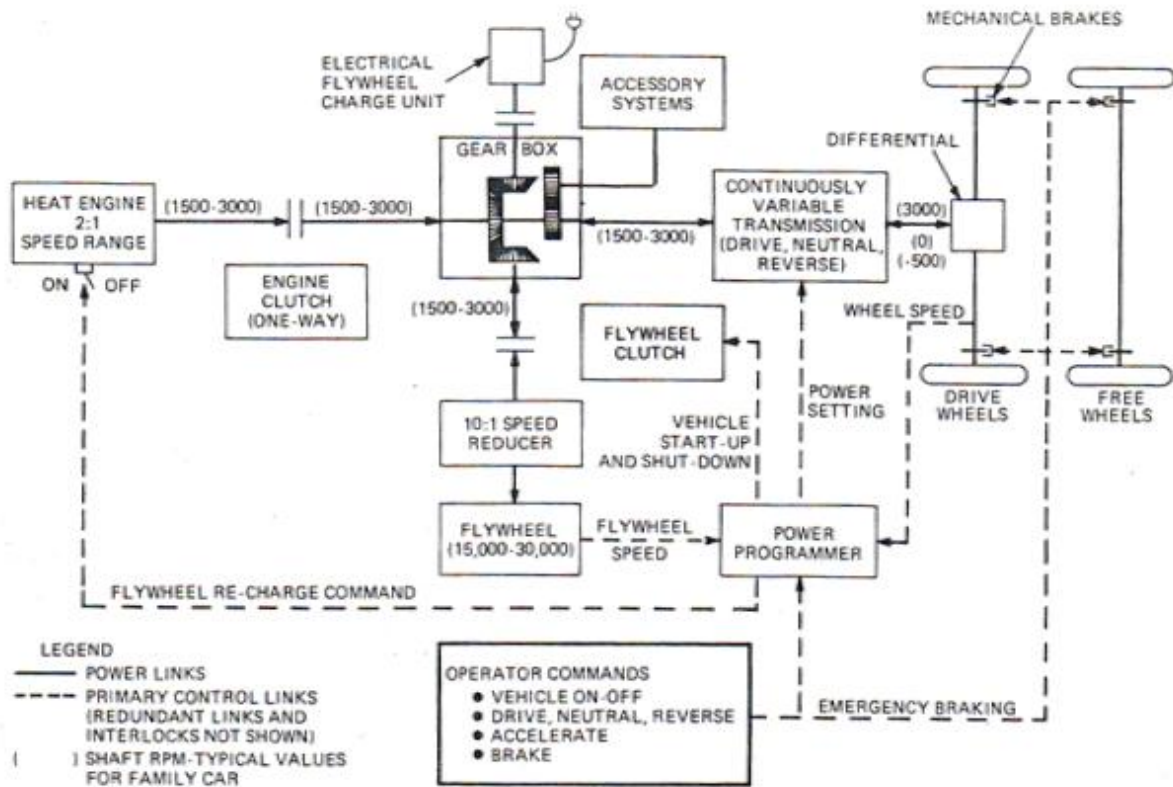

Figure 8 Concept from Dugger

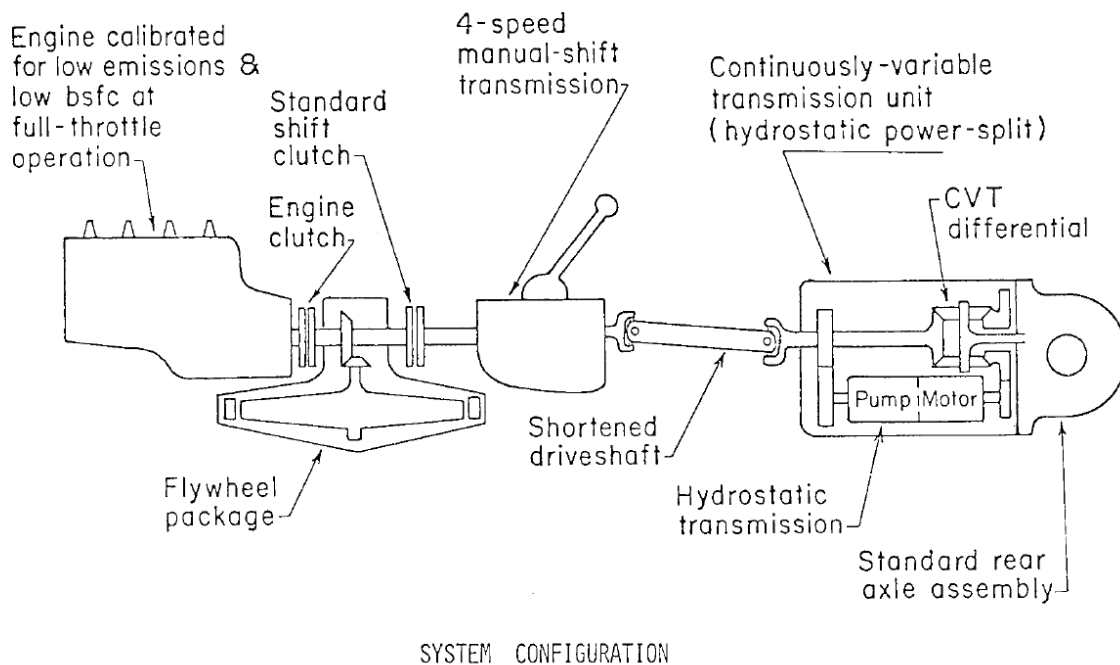

Figure 9 Concept from University of Wisconsin-Madison

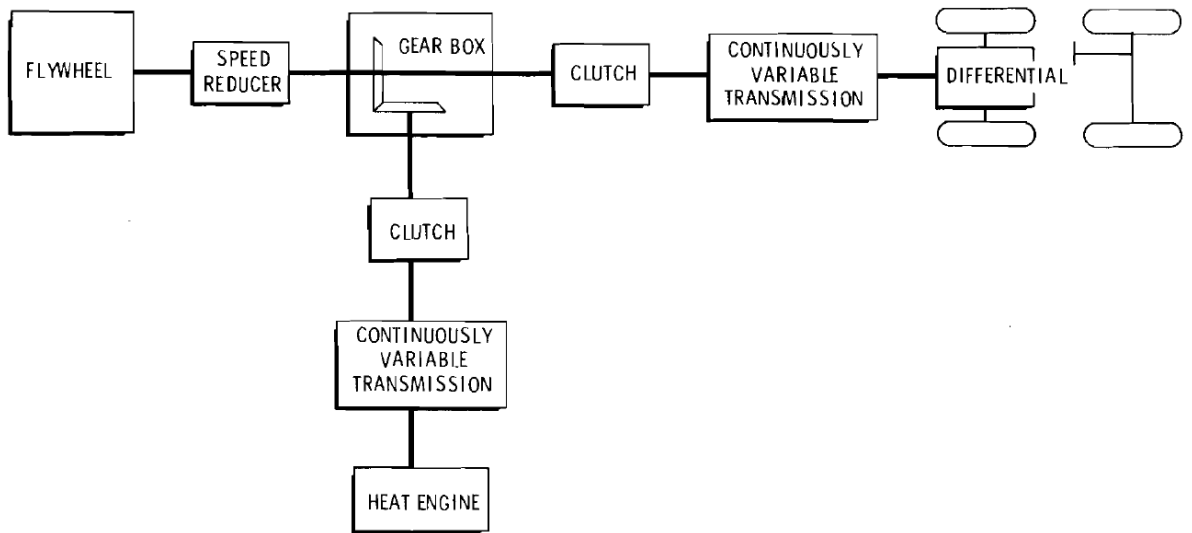

Figure 10 Concept from Loscutoff

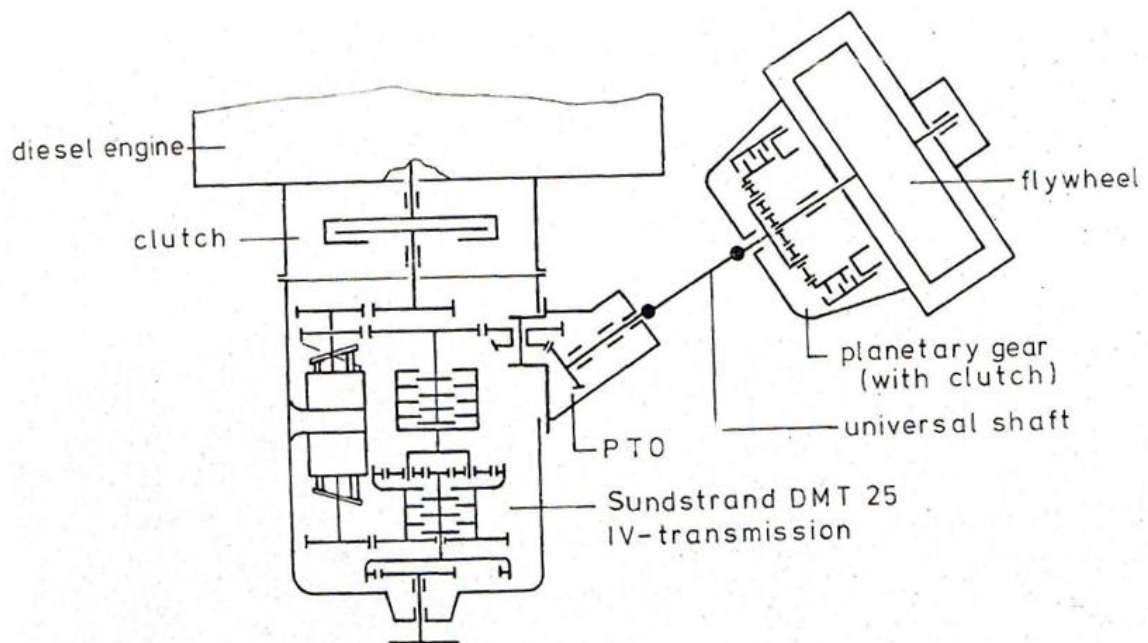

Figure 11 MAN bus

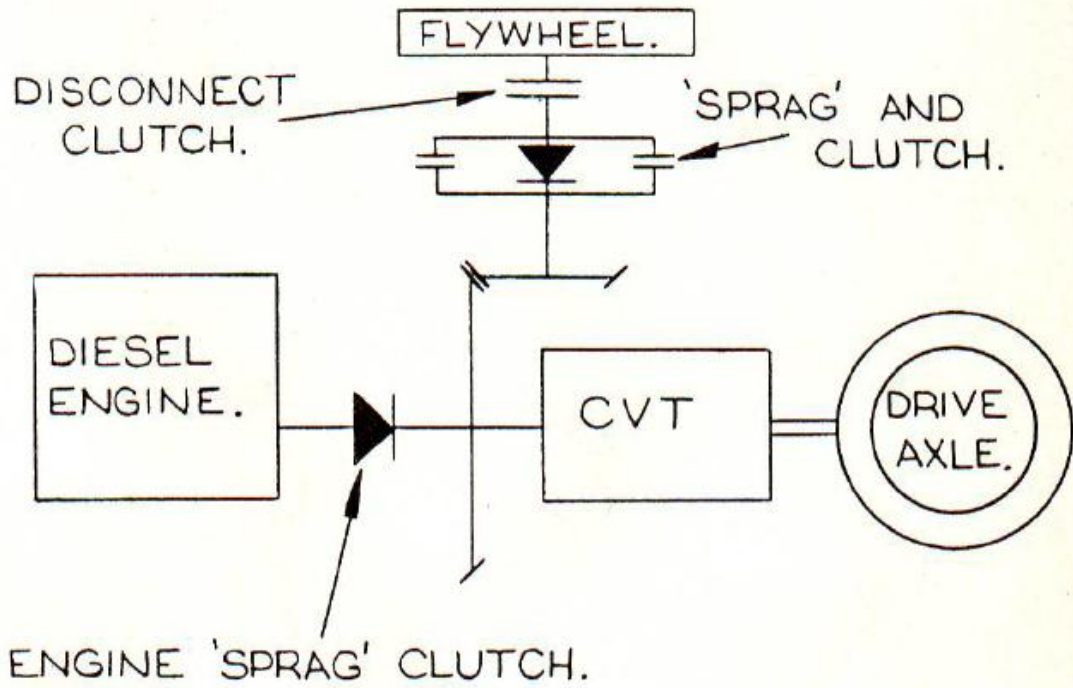

Figure 12 Concept from Greenwood

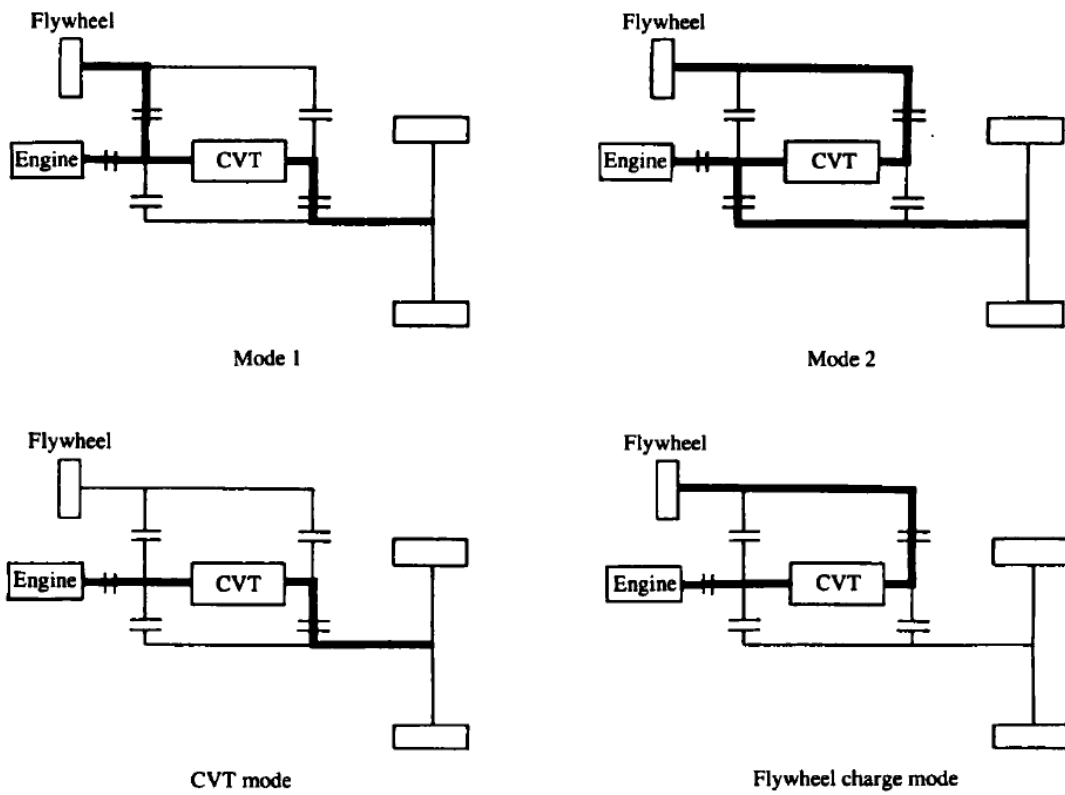

Figure 13 GM two mode concept



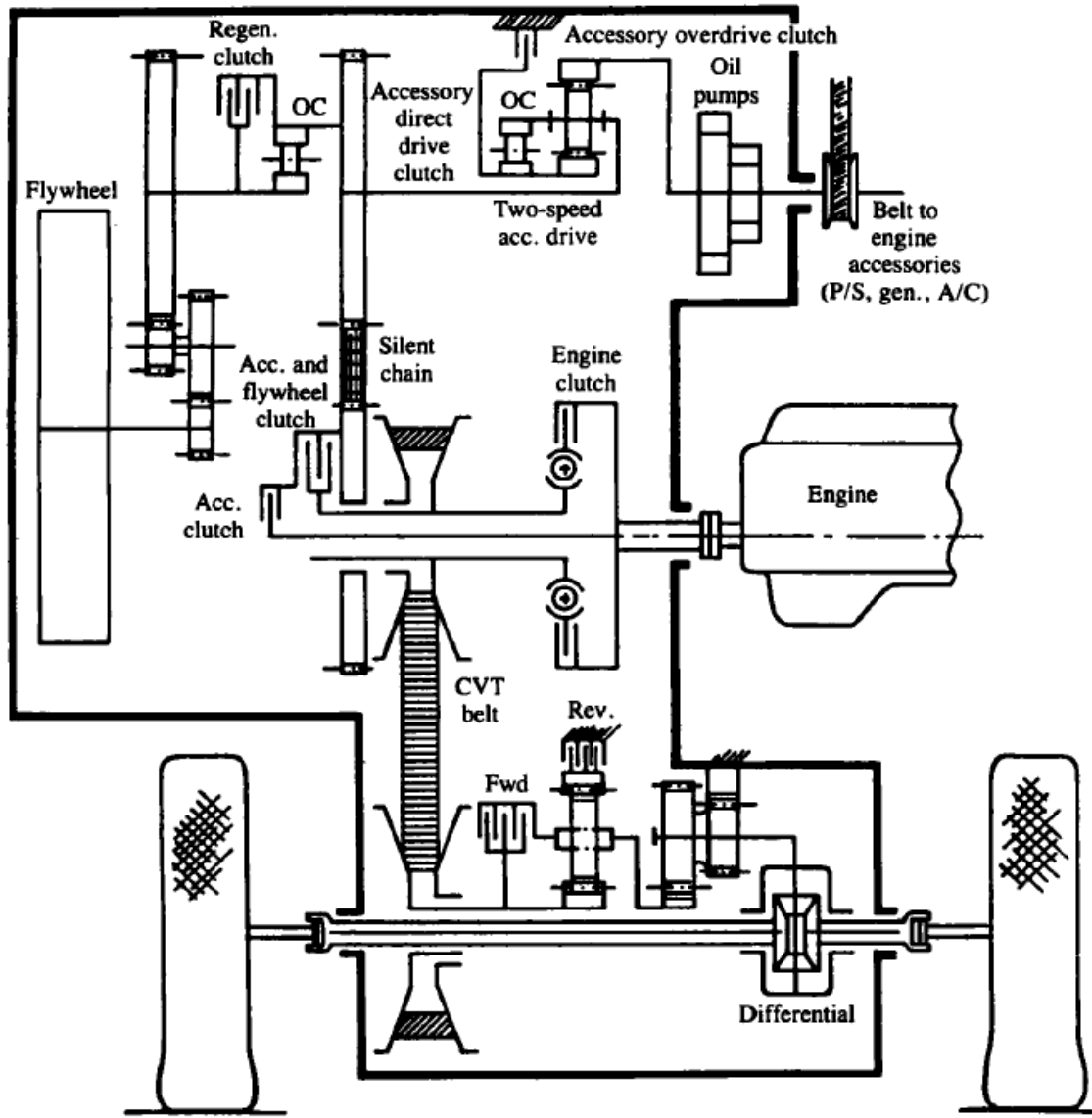

Figure 14 GM hybrid concept

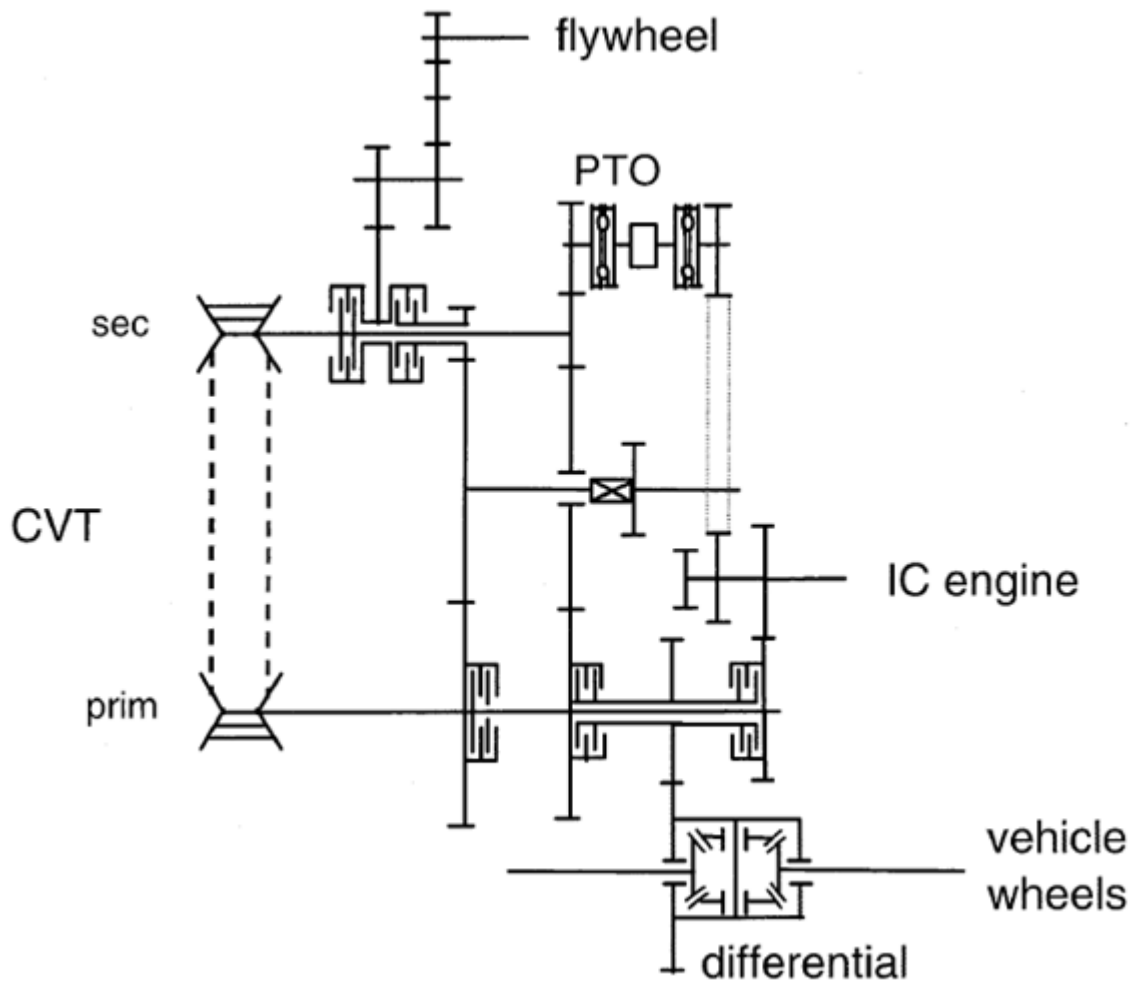

Figure 15 Concept from Kok

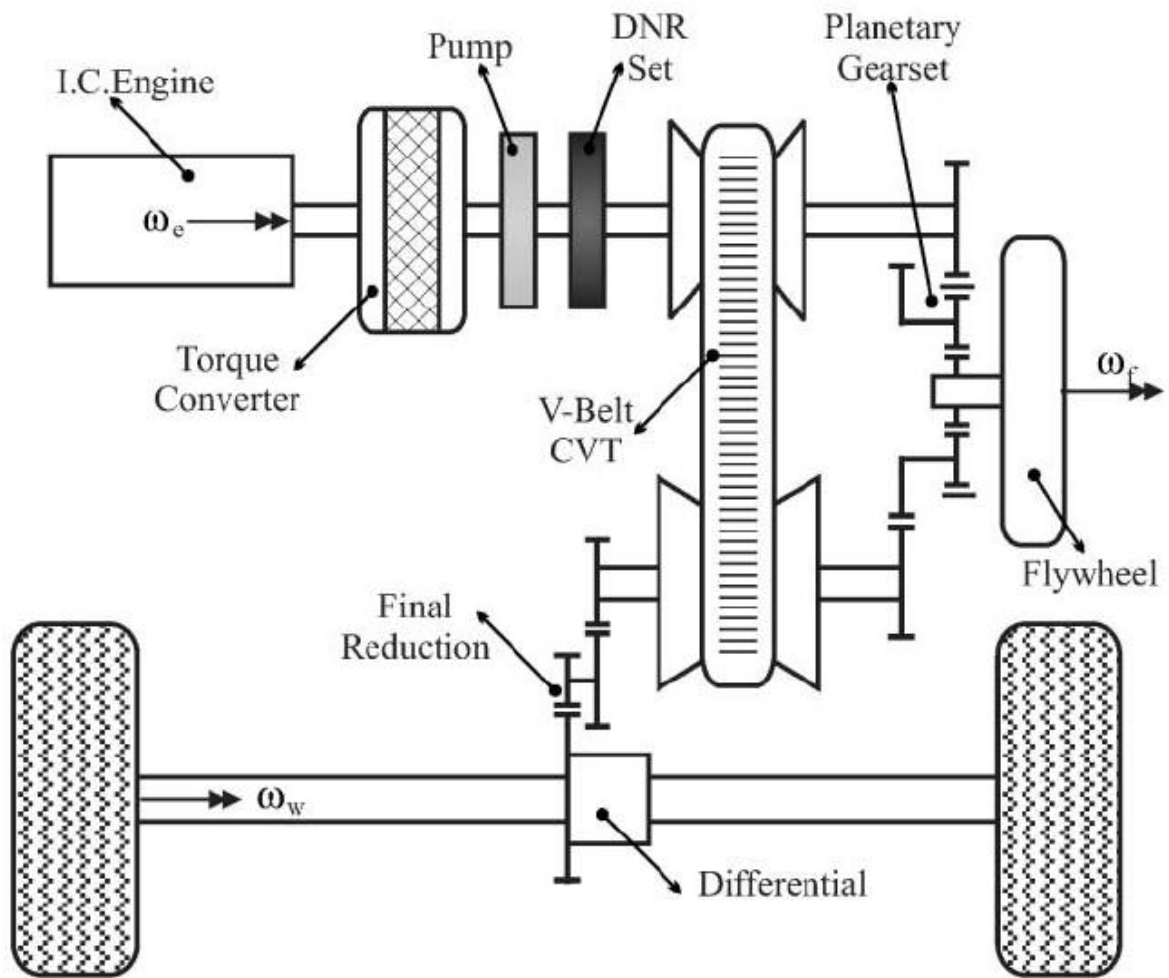

Figure 16 Zero Inertia Powertrain

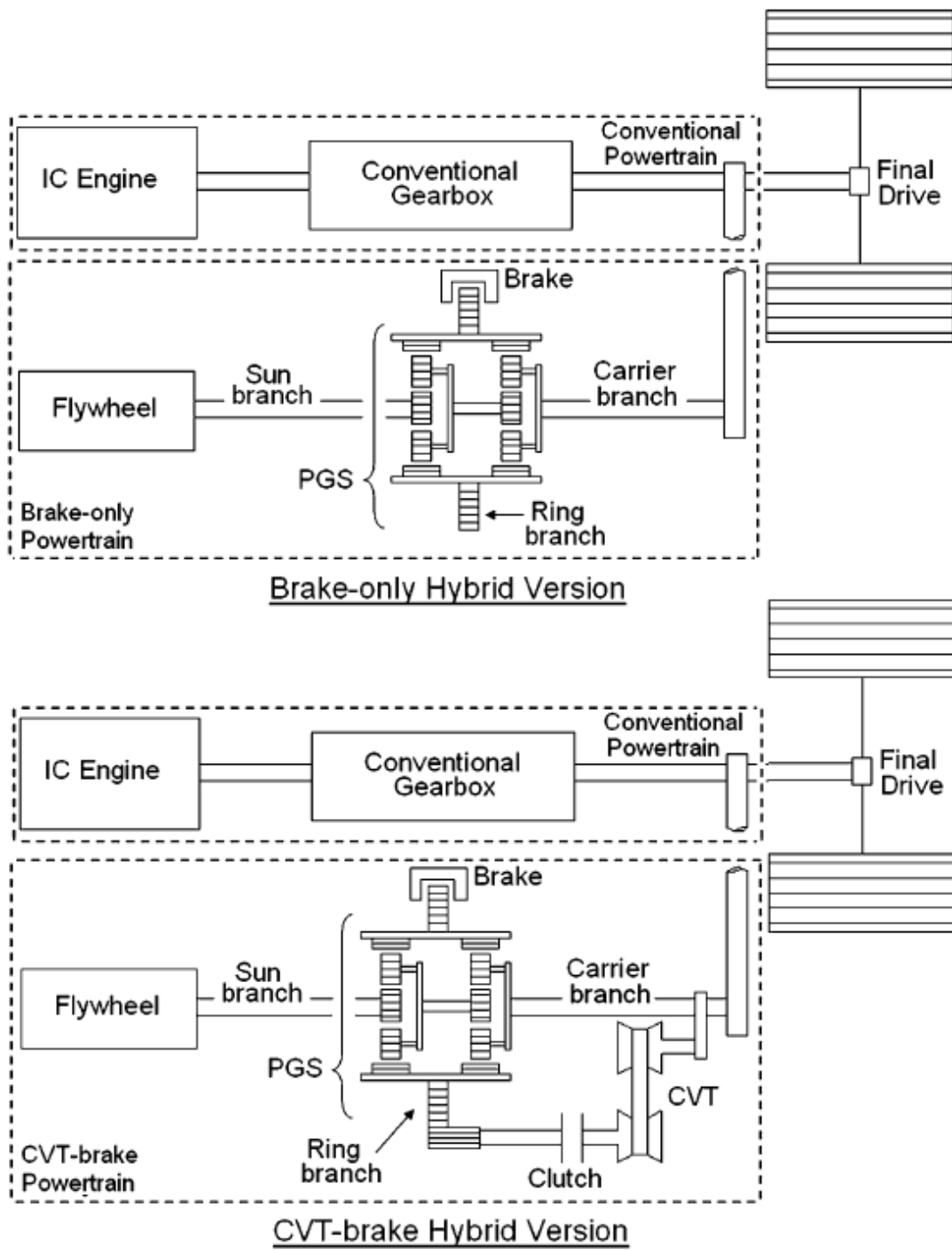

Figure 17 Concept from Diego-Ayala

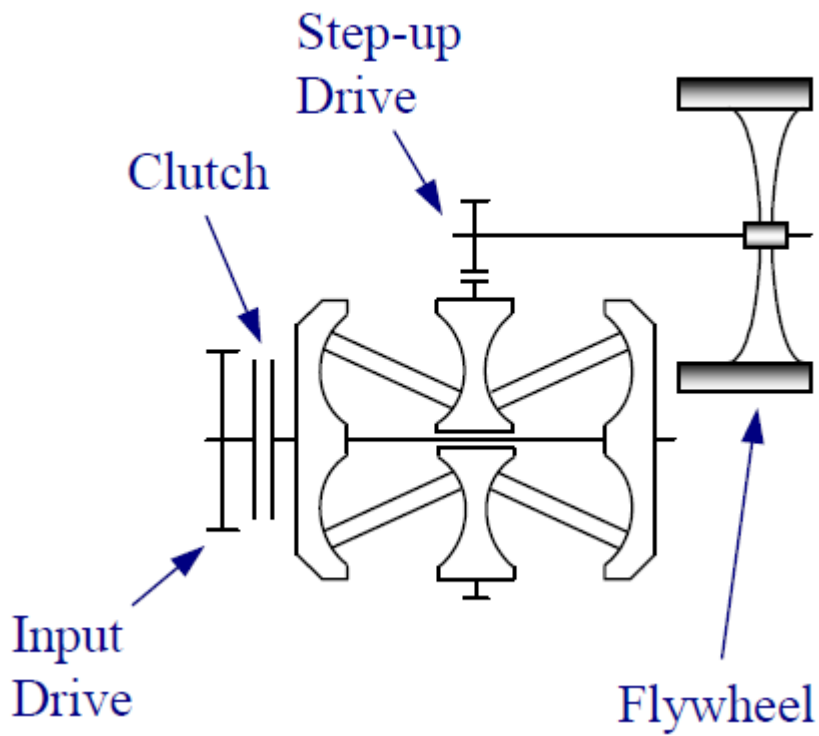

Figure 18 Flybrid Torotrak system

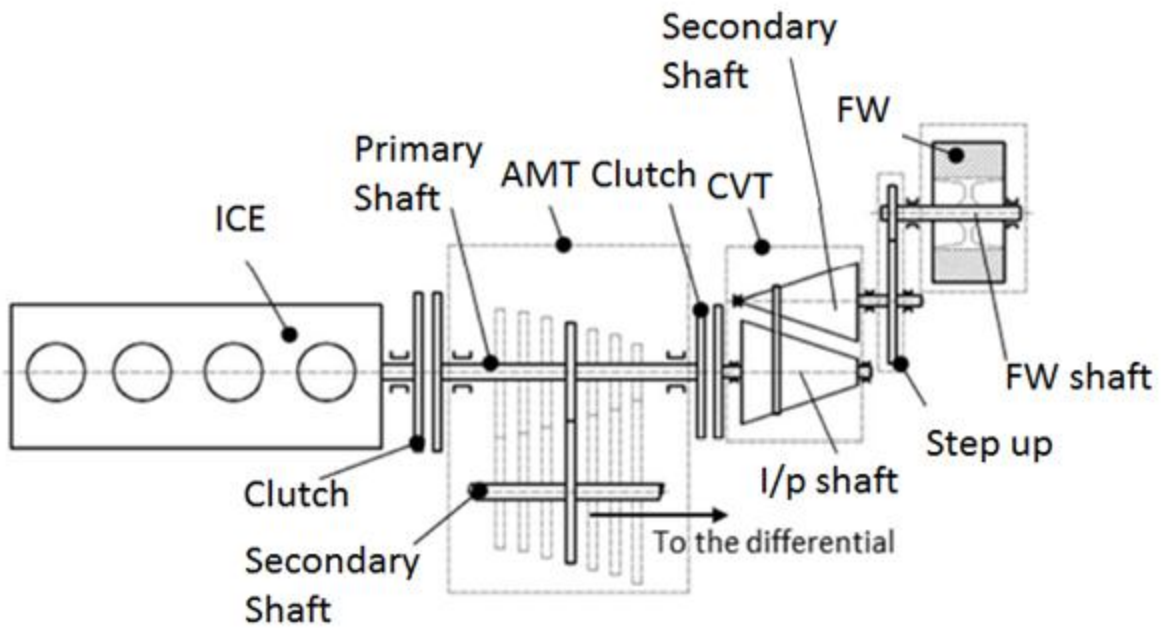

Figure 19 Concept from Trivić