



# City Research Online

## City St George's, University of London

**Citation:** Jeffreys, A. (2023). Making, Dwelling, and 'Discontinuous Continuities': Finding Musical Form within the Inner Life of Materials. (Unpublished Doctoral thesis, City, University of London)

This is the accepted version of the paper.

This version of the publication may differ from the final published version. To cite this item please consult the publisher's version.

**Permanent repository link:** <https://openaccess.city.ac.uk/id/eprint/31670/>

**Copyright and Reuse:** Copyright and Moral Rights remain with the author(s) and/or copyright holders. Copies of full items can be used for personal research or study, educational, or not-for-profit purposes without prior permission or charge, unless otherwise indicated, provided that the authors, title and full bibliographic details are credited, a hyperlink and/or URL is given for the original metadata page and the content is not changed in any way. For full details of reuse please refer to [City Research Online policy](#).

Making, Dwelling, and 'Discontinuous Continuities':  
Finding Musical Form within the Inner Life of Materials

Alice Jeffreys

Thesis submitted to City, University of London  
in partial fulfilment of the degree of Doctor of Philosophy.

City, University of London  
School of Arts and Social  
Sciences Department of Music

# Table of Contents

<b>Acknowledgements</b>	<b>2</b>
<b>Abstract</b>	<b>3</b>
<b>1. Introduction</b>	<b>4</b>
1.1 Introduction	4
1.2 Making and Dwelling	5
1.3 Discontinuous Continuities	7
1.4 Listening and Memory	10
1.5 The Portfolio	11
<b>2. Abstract Form: YX and For PlusMinus</b>	<b>13</b>
2.1 Introduction	13
2.2 <i>yx</i> (2017)	14
2.3 <i>for PlusMinus</i> (2018)	34
2.4 Conclusion	54
<b>3. The Composition Portfolio</b>	<b>56</b>
3.1 Introduction	56
3.2 <i>for serge</i> (2018)	56
3.3 <i>inside-out</i> (2019)	82
3.4 <i>finding a thread</i> (2021)	103
3.5 Conclusion	136
<b>4. Conclusion</b>	<b>138</b>
4.1 Introduction	138
4.2 Form-finding	139
4.3 Emergent form	141
4.4 Final thoughts and future directions	143
<b>Bibliography</b>	<b>145</b>

## Acknowledgements

To Dr Newton Armstrong, thank you. These two words feel so inadequate to capture so much. Thank you for accompanying me on this journey of academic, creative, and personal discovery. Thank you for your guidance, insight, wisdom, and honesty. For your generosity of time. Your commitment and dedication. This project is what it is in part because of you.

To my autism support tutors, Jannett Morgan and Emma Allsopp, thank you for seeing me and hearing me. For helping me to find my voice. To find my 'can'. This project is dedicated to you and the incredible neurodivergent people you work with.

To all the artists who helped to bring the works to life, thank you for your invaluable insight. For sharing your passion and infectious enthusiasm:

- *yx*: Ensemble x.y and conductor Toby Thatcher.
- *for PlusMinus*: Plus-minus Ensemble and conductor Mark Knoop.
- *for serge*: Soloist Serge Vuille. The Kammer Klang team and the staff at Café OTO.
- *inside-out*: Riot Ensemble and Aaron Nahum Holloway.
- *finding a thread*: Explore Ensemble and Nicholas Moroz.

To my Mum and Dad, you made this possible.

## Abstract

This project is about musical form. A certain kind of form. Form as something that comes about through things, how those things interact, and how we interact with them. It is about a certain way of encountering form as an artist based on dwelling within things. Dwelling within the inner life of materials in anticipation of what might emerge. It is about listening. Listening as an experience of occupying and discovering form. Of corresponding with things. Moments corresponding with echoic traces. It is about continuity. Continuity as a lived experience of things. A sense of relationship discovered through time and felt in retrospect. It is about the way these ideas might play out as a sense of difference, tension, or contradiction, between the way something seems to unfold from one moment to the next and the sense we have of it in retrospect. Something like 'discontinuous continuities.'

This thesis traces the journey and evolution of these ideas about form, making, continuity, and listening through the stories of five pieces composed between 2017 and 2021. It is a journey of two halves. Abstract form. Form-finding. Form *before* things to form *from* things. A journey to encountering form, as an artist, as a lived experience of things. Form-finding as a process of dwelling within things. The pieces tell a story of the emergence of a certain kind of continuity that flows from my dwelling within things. From an intuitive correspondence with things.

# 1. Introduction

## 1.1 Introduction

This project is about many things. Musical form. Making. Continuity. Listening. How these things might relate. How form and continuity might play out or be encountered within the act of making. How they might come about and be experienced within the act of listening.

The project began with a dialogue. A dialogue about form. About continuity. About a tension, or gap, between my sense of, assumptions about, and encounter with these things as an artist, and my sense and experience of these things as a listener. As an artist, I had been encountering form as something that comes *before* materials within the act of making and something that is *told* within the act of listening. I thought of time as linear, and goal orientated. Listening as more passive than active. The listener as more of a recipient than a participant. In contrast, as a listener I was developing an awareness of music's capacity to engender a rich variety of formal and temporal experience. I wondered if these things might be intertwined in some way. The way form might come about, and the kinds of qualities time might acquire. I sensed two other things, curious things, that seemed closely related. Interpenetrative, even. Firstly, the nature of a listener's role in their experience of form and time. By this, I mean the kind of role ascribed to a listener or what the musical situation asks of the listener. Secondly, the way certain situations seem to engender a greater sense of something like resonance and depth. An enduring impression of sorts that seems to acquire complexity through time. A kind of entanglement through time.

This dialogue led to questions about how continuity might come about in my music. Can continuity be a sense that we, as listeners, acquire over the duration of a music's unfolding? Can this sense feel in some way contradictory with how we experienced the moment-to-moment unfolding? Can I, as an artist, and we, as listeners, experience continuity retrospectively as a kind of acquired sense of resonance and depth? I think these questions frame form as something that comes about through things, how those things interact, and how we interact with them. These areas of enquiry seem complex, vague, difficult to pin down, interpenetrative, and dynamic. Yet, they seem to have potential to expose and open up pathways to different ways of thinking about form and continuity in my practice. How these things might be encountered within the act of making and experienced within the act of listening.

The sections that follow explore more fine-grained aspects of my thinking about making, continuity, and listening. Musical form underpins all of these. To borrow from Tim Ingold's writings on correspondences, they are, I think, all about becoming part of the story of things.<sup>1</sup> Making is about a certain way of encountering form based on dwelling within the inner life of things, of materials. Continuity is about a lived experience of things, and the sense of relationship discovered through time and felt in retrospect. Listening is about occupying and discovering form. The formal significance things acquire through time depends on memory. On *our* memories. Listening and memory as an intrinsic aspect of what we sense form to be. These things – form, making, continuity, and listening – seem curiously interpenetrative. I sense to speak about form as a certain kind of lived experience of things is to speak about making. About listening. Continuity.

## 1.2 Making and Dwelling

Form comes about through things, how those things interact, and how we interact with them. As I ponder this, several words come to mind. Temporal. Correspondence. Active. Tactility. Textility. I sense these are not discrete qualities. But interpenetrative in some way, perhaps. I wonder what they suggest about how I might encounter form within the act of making, and how a listener might experience form within the act of listening. The word *dwelling* comes to mind. Dwelling *within* things. As artist. As listener.

Making as a process of dwelling within things in anticipation of what might emerge. I think this process will feel not unlike correspondence. A certain kind of correspondence. Playing out through time. Dwelling as a real-time correspondence with things. A correspondence based on mixing, merging, and melding with things. I think this might feel like a kind of interplay between the things and myself. An interplay between following, uncovering, revealing, and responding, perhaps. Dwelling as a process of following the suggestions and wanderings of things. I wonder if this process, this interplay, this live correspondence, might be not unlike listening. Discovering the inner life of things through listening to things and following those things. A kind of feedback loop between listening and responding. I sense this will be a very active process. Something like becoming enmeshed in things and their evolving relationships. An organic kind of evolution. Sort of like becoming entangled with things and instinctively feeling my way within and through an evolving space. A certain kind of tactility. I wonder if the act of listening might

---

<sup>1</sup> Ingold (2021): 7.

feel not unlike this too. Listening as an experience of dwelling within things. Something like occupying and discovering form.

I think this idea of dwelling within things, whether as an artist or as a listener, is about a certain kind of encounter with, or way of experiencing, form. Form-finding as a process of dwelling. I am thinking here about form as a sense I acquire in correspondence with things. Form as something that I gradually find as I dwell within things. Dwelling as a process of allowing things to acquire their formal significance through time. Form as a retrospective sense.

I think to dwell within the 'inner life' of the materials, of the unfolding moments and their echoic traces, will be akin to a lived experience of things. A process of gradual discovery. Gradually acquiring a sense of their qualities and behavioural tendencies, and their ways of relating. Anthropologist Tim Ingold illustrates something not unlike this idea of form as lived experience, using his experience of the practice of basket weaving. In his book *Making*, Ingold reflects on the surprising resistance of the willow to being forcibly bent into a shape and the dynamic kind of force field this generates between the weaver and the willow. A certain kind of in-between space where willow and weaver meld and merge. For Ingold, a sense of form emerges within this very force field, within this tactile correspondence between weaver and willow. Within this dynamic space, within this correspondence between maker and material, form is ever emergent. In other words, form is '...comprised by the relations between the weaver and the willow...'.<sup>2</sup> Ingold reflects on the way he came to know the willow, to gradually develop '...a rhythm and a feel for the material...' through time.<sup>3</sup> A kind of '...intuition in action...'.<sup>4</sup> Comparing his own basket to those of his fellow makers, Ingold reflects on the unique quality of each basket. He notes how, '...each basket was different, uniquely reflecting the mood and temperament, as well as the physical stature, of its maker'.<sup>5</sup> Form as a lived experience of things. A process of discovery. A process of active following. 'To know things, you have to grow into them, and let them grow in you, so that they become a part of who you are.'<sup>6</sup>

---

<sup>2</sup> Ingold (2013): 23.

<sup>3</sup> Ingold (2013): 23.

<sup>4</sup> Ingold (2013): 25.

<sup>5</sup> Ingold (2013): 23 – 24.

<sup>6</sup> Ingold (2013): 1.

### 1.3 Discontinuous Continuities

Expressed as a basic premise, these ideas about form as a lived experience of things might go something like this – we have a tendency to slowly assemble a picture through time as context accumulates. This suggests a kind of situation where we grasp or make sense of something by framing it in the context of what we have already experienced. A situation where we understand things relationally. This kind of situation might play out as something like ‘discontinuous continuities’. I think we might experience this as a sense of difference, tension, or contradiction, between our experience of the music in the moment and the sense or impression we have of the thing with time. A difference between the way that something seems to unfold from one moment to the next and the sense we have of it in retrospect. I wonder if this might infuse our experience with a certain sense of paradoxical-ness. A sense of form that seems to acquire paradoxical qualities through time. It might have implications for the way we feel time unfold. I wonder if the way we feel time unfold from one moment to the next might be different to the sense or impression we might have of time’s unfolding in retrospect. A sense of something resembling continuity emerging out of something that felt discontinuous, perhaps. I sense this kind of situation, of ‘discontinuous continuities’, might have implications for the way we listen. I think it has potential to engender a certain kind of active listening. Perhaps, a kind of heightened listening attention or awareness.

Something not unlike a situation of ‘discontinuous continuities’ is at play in Morton Feldman’s solo piano work *Palais de Mari* (1986). Here, it seems to lend to the form a certain kind of paradoxical quality. Dora Hanninen hints at this acquired paradoxical quality in her analysis of the piece published in *A Theory of Musical Analysis* (2012). This paradoxical quality goes something like this – there is a sense of contradiction between what I grasp in the moment and the way I feel the music move from one moment to the next, and my sense or impression of it in retrospect. It feels like some kind of interplay is at play between what I grasp in the moment and what I sense, or come to grasp, later. An interplay between actual moments and memories, perhaps. The way I feel time unfold seems contradictory. Initially, within the shifts from one moment to the next time feels fragmented. Discontinuous. But as the piece unfolds, I become increasingly aware of a sensation of relationship. Aware that I am somehow following a thread of some kind.

Borrowing from Hanninen’s analysis, Feldman seems to engender this sense of tension through a principle of surface and sub-surface differences. By this, I mean there is a difference between how the music plays

out in the moment and how things happen or unfold just beyond my immediate awareness. Feldman's materials comprise seven self-contained material-types with highly distinctive configurations. He presents instances of these in a fragmentary way with frequent abrupt shifts. Moments feel discrete. Connections, if there are any, are not immediately apparent. For example, in the opening thirteen bars Feldman presents several instances of two kinds of material.

2

**Palais de Mari**  
for piano (1986)



**Morton Feldman**  
(1926–1987)

$\text{♩} = 63-66$

Figure 1.1: 'Palais de Mari' (1986) for solo piano, bb.1 – 13 (material-type A, bb.1 – 6; material-type B, bb.7 – 13)

In experience, material-type A feels relaxed, resonant, open, and incomplete somehow. It seems to hover, sort of like it has just posed a question or left something unsaid. Material-type B, on the other hand, seems contained, insistent, and tense, with little suggestion it is going to vary. The shift from A to B feels jarring and stark. Their different kinds of presence suggest discontinuity and disconnection. They engender a sense of disorientation and confusion. This prompts me to actively look for threads of connection.

Material-types A and B relate in several different ways through the domain of pitch and interval. The first and third instances of type A share two common tones with type B. Pitch class E and pitch D#5. The second instance of A shares the interval of a semitone with B. Embedded in the pitch field of A is a cluster of three semitones: <D# E F>. An aspect of this is made clearly audible in the second instance via a slight rhythmic displacement in the left-hand which alters the temporal order of the pitches. <F4 D#5 E4> becomes <F4 E4 D#5>. In type B, this semitonal cluster is effectively transposed down a semitone to <D D# E>. Curiously however, this

downward transposition of pitch classes is somewhat offset by the way B presents the semitonal cluster. Differences in octave placement infuses the profile of A with an overall descending quality and the profile of B, conversely, with an overall ascending quality. This seems to heighten the sense of tension. Via temporal ordering the semitone as an ascent from D5 to D#5 is clearly felt in B.

These shared qualities embed a very clear connection between the material-types suggestive of continuity. However, this kind of union seems easily missed in the immediate moment. The shared qualities seem to be more difficult to immediately grasp than differences in character, like timbre and register, temporal weight, and spacing. These differences in character seem to direct my conscious awareness away from the shared qualities. They are effectively concealed underneath the surface of the music in the moment.

These opening bars constitute the only appearance of material-type B. Feldman continues to present instances of the other material-types, including A, in alternation, with or without frames of latent silence, over the duration of the piece. For example, in b.14 to b.35 type A is presented in alternation with types C and D.



Figure 1.2: 'Palais de Mari' (1986) for solo piano, bb.14 – 35

As instances of the material-types are presented in, and interact with, different contexts, those things at play in the music's surface seem to shift. Different sets of parametric qualities pertaining to the materials seem to be heightened (i.e. made more intense) or exposed (i.e. made known), and highlighted (i.e. attention drawn to) or

concealed (i.e. hidden). As the situation unfolds through time and the context accumulates, my sense of how things relate seems to change. Not in a way that I can grasp or pin down in the moment. Some things that initially felt disconnected start to acquire a sense of relationship. Almost like Feldman is presenting a problem in one temporal location and its solution in another. It is as though something is unfolding just below my immediate radar. Something that neither contradicts nor corresponds with my impression of the thing from within the moment to moment unfolding. Something that I can sense in retrospect. This way of encountering *Palais* feels not unlike a kind of entanglement through time. I find this kind of situation curious. For the way it seems to actively ask things of me as a listener. The way it seems to evolve within a space somewhere in-between me and the music itself. The way I seem to find a sense of form within this entanglement.

The way this idea of 'discontinuous continuities' plays out in my practice evolved over the course of the project. It began as a kind of conscious 'engineering' of 'discontinuous continuities'. A conscious attempt to 'engineer' a sense of discontinuity within shifts from one moment to the next, and a sense of tension or contradiction between moment-to-moment unfolding and retrospective impressions. I thought of this as something like 'leaving gaps'. Engineering changes of context that might call into question our assumptions about form. Embedding threads of connection for a listener to find. To pull out of context. This played out as a very conscious abstract 'working out' of surface and sub-surface differences. Within the shift from *for PlusMinus* (2018) to *for serge* (2018), these ideas broadened out. They acquired flexibility and an organic and intuitive quality within the act of making. My practice shifted towards a music where continuity follows more or less intuitively from my dwelling within things. As I dwell, I discover things. These things engender a sense of difference or tension between my sense of something and what the moment suggests. These tensions feel like gaps of a kind. Not holes. But something like shifts in viewpoint. Moments of adjustment. The space in-between following and responding, perhaps. These 'gaps' feel participative. Organic. Numerous. The potential pathways to somewhere.

## 1.4 Listening and Memory

We experience music through time. It is at once disappearing and emerging. It interacts with memory. Depends upon memory. Leaves traces in memory. These traces are fragile. Vulnerable to change. To distortion. To loss. Memory is dynamic. Our sense of how things might relate is unstable. Relative. Traces are inevitably

reframed by everything that follows. Our sense of how things might relate evolves with this. Things acquire their formal significance through time. Form is occupied and discovered. A sense we acquire. Memory feels intrinsic to this.

I wonder if a situation of 'discontinuous continuities' might have certain implications for memory. I sense it might play out as a certain kind of dynamic correspondence between immediate/actual moments and echoic traces. A kind of drawing on memory to find threads of continuity or things that might suggest continuity. I think the expression 'discontinuous continuities' implies a kind of situation that actively calls on memory *and* plays with the limits of memory. These kinds of correspondences and interactions seem to frame continuity as something that is active and dynamic. A kind of shifting viewpoint. I wonder about the role or presence of context and recontextualisation in listening experience. About the way context and memory might interact. I sense the qualities of memory, these kinds of correspondences, have potential to set-up a very dynamic listening situation. To lend a certain kind of richness to experience in listening.

## 1.5 The Portfolio

The portfolio consists of five pieces: *yx* (2017), *for PlusMinus* (2018), *for serge* (2018), *inside-out* (2019), and *finding a thread* (2021). Broadly speaking however, these pieces can be divided into two groups. Abstract form. Form-finding. The division is highly significant. It recognises a difference, a moment of shift, in the way I encounter form within the act of making. Abstract form is about form *before* materials. Form-finding is about form *from* materials. *for serge* (2018) reflects the moment this became something that happens intuitively within the act of making. By this I mean the moment that I encountered form as a lived experience of things. A lived experience based on dwelling within the inner life of the materials, listening and intuitively responding/feeling my way.

Each piece embodies a different stage of the project. The act of making *yx* (2017) was a trial of new working processes in response to the basic premise about form and continuity that might deal with form and time in a complex way. A reorientation of my creative practice. This infused the working process with a strong theoretical quality. The working process began with a sense of how a group of unknown things might relate and how their relationship might become more entangled and acquire complexity through time. This sense of a possible musical form acted not unlike a guide as I set about finding materials. Similarly, the act of making *for PlusMinus* (2018)

was about form *before* materials. There are differences, however. The sense of an abstract form I found was vaguer and less prescriptive. The details of the form gradually emerged as I found the materials and they revealed their qualities and behavioural tendencies. This process felt more intuitive and flexible. Something like a sense of correspondence, as I sought to listen to the materials and respond to their suggestions.

*for serge* (2018) stands apart from *yx* and *for PlusMinus*. The act of making was a process of dwelling within things. Things in a moment of becoming. As I listened to, followed, and responded to these things they acquired their formal significance. Making felt intuitive, dynamic, and participative. Similarly, the act of making *inside-out* (2019) was about form *from* materials. Form following materials. Form as something that I find as I dwell within the inner life of the materials. I think dwelling took on a different dimension in making *finding a thread* (2021). As I dwelled and very gradually discovered the thread of the work, I had a certain kind of palpable awareness/sense of being a participant in a lived experience of the materials. A very part of the emerging and evolving landscape. As a dweller. As a wanderer. Thinking *through* making. Dynamic. Temporal. Intuitive. Organic. My retrospective impression of making feels infused with a certain kind of resonance and depth. To a degree, or in a way, that seems to distinguish it from my experience of form-finding in *for serge* and *inside-out*.

The next chapter focuses on abstract form in *yx* and *for PlusMinus*. Chapter three is about form-finding in *for serge*, *inside-out*, and *finding a thread*. The final chapter takes the form of a reflective summary.

## 2. Abstract Form: *YX* and *For PlusMinus*

### 2.1 Introduction

This project began with a dialogue about how continuity comes about in my music. This led to a question: can continuity be a sense that we, as listeners, acquire over the duration of a music's unfolding? In other words, can we experience continuity retrospectively as a kind of acquired sense of resonance and depth? Expressed as a basic premise, this way of thinking about continuity goes something like this: we have a tendency to slowly assemble a picture through time as context accumulates. Creatively, this idea appeals because it frames musical form as something that is gradually discovered or found rather than told. In other words, something that comes about through things and how those things interact, and how we interact with them. This is very significant. At the start of this project, it took my creative self out of myself and prompted a trial of completely different ways of working and a reorientation of my creative practice.

This portfolio consists of five pieces composed between 2017 and 2021. They tell the story of the reorientation of my practice. They are called *yx* (2017), *for PlusMinus* (2018), *for serge* (2018), *inside-out* (2019), and *finding a thread* (2021). All respond to the basic premise in a unique way, which is to say the idea of form as something that emerges within the acts of making and listening. However, broadly speaking, these responses can be divided into two groups: abstract form and form-finding. This division is based on how form comes about within the act of making and how the form and materials relate. This line, drawn between *for PlusMinus* and *for serge*, is highly significant. It marks the moment of shift from form *before* materials to the idea of *form-finding*. By this, I mean the moment when I started to find form within the materials, within the act of making, by intuitively feeling my way. It is a difference, perhaps, between something growing into itself and something growing out of itself. Despite their differences, all the pieces are about a kind of musical form that depends upon time to make itself known, to slowly fall into place, in experience; and they are about engendering an active and lead role for the listener in their experience of form.

## 2.2 *yx* (2017)

### 2.2.1 Introduction

*yx* is scored for flute, grand piano, violin, violoncello, and double bass. The overall duration is approximately twenty-two minutes. It was premiered by Ensemble x.y on Friday 9<sup>th</sup> June 2017 at City, University of London. The starting point for this piece was the basic premise about how continuity might come about and play out. It sparked my curiosity because it suggests that we tend to grasp or make sense of something by framing it in the context of what we have already experienced, which is to say, we tend to understand things relationally. In this sense, the picture referred to in the basic premise can be thought of as a certain kind of retrospective view or enduring impression of the global thing. *yx* is an attempt to set up a kind of musical situation with the potential to engender a sense of tension or contradiction between our experience of the music in the moment and the sense or impression we have of the thing with time. I was thinking about a musical situation with potential to prompt a kind of rummaging around in memory to find connections, those things that we perhaps missed or mistook in the moment, from which a picture could slowly emerge, or a thread could be found. The sense of contradiction I was interested in is continuity concealed within discontinuity. By this, I mean a kind of situation where our immediate experience is characterised by a sense of discontinuity and disorientation, yet as the thing unfolds, and we are able to find and latch onto threads of connection within the shifting shapes of the accumulating context, we experience a distant sense of a coherent plot unfolding. Something that felt discontinuous starts to take on, or acquire, a sense of continuity and connection; in other words, a sense of form that acquires paradoxical qualities through the duration of its unfolding.

My intention was to embed continuity within discontinuity using the principle of surface and sub-surface differences gleaned from Morton Feldman's *Palais de Mari* (1986). This necessitated some specific intentions with respect to the compositional materials. These are modelled, in a general way, on the kinds of active criteria observed in *Palais de Mari*. By active criteria, I mean things somehow inherent within the music itself, independent of the listener, that might have the potential to evoke a specific variety of formal experience in listening. In brief, these intentions were:

- To work with a limited pool of material and the variety inherent within (e.g. non-developmental variation) to engender a musical situation that deals with form in a complex way.



a surprising and interesting degree of back-and-forth between the abstract sense of form, the emerging materials, and myself. A slightly different sense of form emerged from this process. It is reflected in the image below.

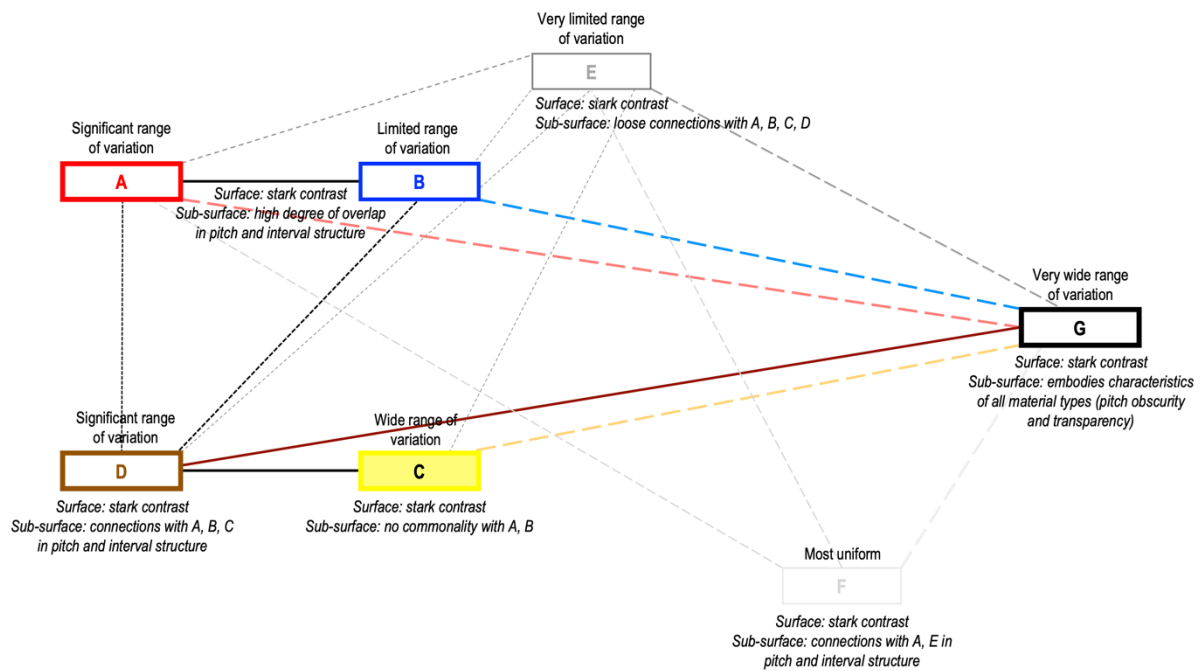

Figure 2.2: Abstract form (after materials)

### 2.2.3 Materials

The seven material-types are self-contained and seem to have highly contrasting configurations. Each material-type has a family of non-developmental variants with characteristic mode(s) and range of variation. The basic configurations of the material-types are as follows –

1 7 2  
8 4 4

♩ = c. 46 - 52

Fl. silence *ppp* edgy metallic tone

Pno. silence *mf* Sost. Ped.

Vin. silence *ppp* *mf* IV SP arco ord.

Vc. silence

Db. silence *ppp* 1/2 SP flaut. SP+

Figure 2.3: material-type A, initial presentation, b.2

Material-type A is scored for flute, piano, violin, and double bass (contrabass). Plays of register contribute to its horizontal profile, which brings to mind what Feldman called the departing landscape. It has a significant range of variation, loosely dividable into three subsets based on how the pitch material is distributed. All subsets vary through shifts in pitch placement which alters the intervallic constellations playing out on the surface.

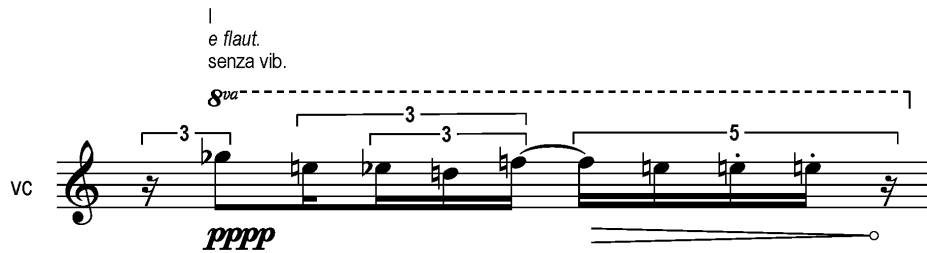

Figure 2.4: material-type B, initial presentation, b.7

Material-type B is scored for the extreme high register of the violoncello. It is characterised by a very narrow register and distinctive rhythmic profile. It varies through shape deformation. Its various guises share the same rhythmic contour but appear very different in terms of the way the rhythm presents on the surface. It has a limited range of variation. Its pitch content is very similar to material A. But it is expressed vertically. This means it plays out on the surface as a different kind of intervallic constellation.

Figure 2.5: material-type C, initial presentation, b.17

Material-type C is scored for flute and violin. It has a very distinctive profile based on contrary motion, a kind of internal agitation, contrasting articulations, and an interval of seven semitones, which is expressed in different ways simultaneously. It has a wide range of variation and multiple modes of variation, namely the way the two layers unfold in relation to one another, transposition, extension, distillation, registral displacement, and instrumentation.

6  
8

pno

*pp*

2

plectrum

2

\* Lightly touch string (shown in brackets) at harmonic node with fingertip and pluck string with plectrum.

vln

*pp*

III (6th)  
ord.  
flaut.

vc

ord.  
flaut.

II (5th)

*pp*

Db

III (5th)  
ord.  
flaut.

*pp*

Figure 2.6: material-type D, initial presentation, b.45

Material-type D is scored for piano, violin, violoncello, and double bass. It is distinctive for its striking transparency and rhythmic simultaneity. It is based on an interplay between compound expressions of intervals of two semitones and five semitones. Its pitch material has correspondences with material-types A, B and C. Plays of register contribute to its identity. It has a significant range of variation and a few modes of variation, namely orchestration, registral displacement, and addition of glissandi and grace notes.

4  
4

55

Fl

normal

*f* *p*

Pno

key

*p*

Soft mallet  
\*Freely move soft mallet across strings within the range of the notated cluster

*pp*

Vln

flout.

*p* *mp*

Vc

flout.

harm. gliss.  
harm. gliss.

*p* *mf*

Db

ord.

5th

*f* *pp* *mp*

Figure 2.7: material-type E, initial iteration of the first 7-event series, b.55

Material-type E is orchestrated to include the entire ensemble. A single instance of the material-type is comprised of a series of glissandi triggered by marked articulations. These are temporally stretched and compressed. As a series, it has limited variation and minimal dispersal across the global landscape. It has a diverse intervallic and pitch content with varying degrees of correspondence with the other material-types.

The musical score for material-type F, initial presentation, b.70, is arranged for piano (pno), violoncello (vc), and double bass (Db). The score is divided into three measures with time signatures of 2/4, 4/2, and 2/4. The piano part begins with a 'silence' in the first measure, followed by a note in the second measure with the instruction 'with palm irregular'. The 'Sost. Ped.' line is active from the start of the second measure to the end of the third. The violoncello part has 'silence' in the first and third measures, and a note in the second measure with instructions: 'IV ord. Heavy bow pressure Noise attack Irregular'. The double bass part has 'silence' in the first and third measures, and a note in the second measure with instructions: 'IV ord. Heavy bow pressure Noise attack Irregular'. In the third measure, the double bass part has a note with instructions: 'III II ord. f/aut.' and a 'ppp' dynamic marking.

Figure 2.8: material-type F, initial presentation, b.70

Material-type F is scored for the extreme low registers of the piano, violoncello, and double bass. This orchestration infuses it with a very distinctive profile. Its play of registers is reminiscent of other material-types. It is the most uniform of all the material-types, with an extremely limited range of variation.

5 3 5 2 3 5  
16 8 16 8 8 16

♩ = c. 80

204

Fl *pp*

Vin *pp*  
IV (5th) 1/2 SP flaut.  
\* flautando bowing until the end of the piece

Vc *pp*  
IV (7th) 1/2 SP flaut.  
\* flautando bowing until the end of the piece

Db *pp*  
IV (4th) 1/2 SP flaut.  
\* flautando bowing until the end of the piece

Detailed description of the musical score: The score is for measures 204 to 210. It features four staves: Flute (Fl), Violin (Vin), Viola (Vc), and Double Bass (Db). Above the staves, there are measure numbers: 5, 3, 5, 2, 3, 5 above measures 204-210 respectively, and 16, 8, 16, 8, 8, 16 below. A tempo marking '♩ = c. 80' is present. The Flute part starts at measure 204 with a *pp* dynamic. The Violin, Viola, and Double Bass parts also start at measure 204 with a *pp* dynamic. Each of these three parts includes the instruction '\* flautando bowing until the end of the piece'. The Violin and Viola parts have specific fingering diagrams for the first measure of each measure, with notes like 'IV (5th) 1/2 SP flaut.' and 'IV (7th) 1/2 SP flaut.'. The Double Bass part has fingering like 'IV (4th) 1/2 SP flaut.'. The score includes various musical notations such as slurs, accents, and dynamic markings.

Figure 2.9: material-type G, initial presentation, bb.204 – 210

Material-type G is scored for flute, violin, violoncello, and double bass. It is presented for the first time in b.204. A single instance of the material is comprised of 7-bars. All the material-types, except for D, which is transparent, explore pitch obscurity via timbre to some degree. Material G is distinctive because it synthesises the characteristics of obscurity and transparency. Two linear trajectories – all twelve pitches of the chromatic scale to one pitch and timbral clarity to total obscurity of pitch – are offset by repetition and discontinuities arising from recontextualisation. It has the widest range of variation.

#### 2.2.4 Interactions Between Materials

When I began the process of assembling the piece from this matrix of all possible variants, I had a vague sense of different landscapes the music might open-up. As the piece began to unfold, I interacted with it and thought of it as a single multi-layered continuum in a chronic state of flux. However, three distinctive landscapes gradually emerged. These differ by the way that the materials interact, which is to say that they have different global properties or behavioural tendencies. The opening, roughly corresponding to bb.1 – 77, has a landscape characterised by diversity of materials. These materials, six types in total, do not overlap and are typically separated by moments of latent silence, meaning they are presented as discrete things forming independent constellations. This has potential to lend a quality of discontinuity to our experience of the music in the moment. There is not a clear line between the first and second landscape. I imagine it more as a kind of space, a duration, somewhere within which we, as listeners, become aware that a shift has occurred. At the score level, subtle shifts in the behavioural tendencies of the landscape begin to unfold around b.78. Any sense of boundary between these landscapes is blurred by the continued heterogeneity of the materials. It is the behaviour of the materials, the way they interact and relate, that changes. They begin to overlap, to play out in parallel, and contribute to the same texture (e.g. one material forms the resonance of another), meaning the landscape is rife with possible synthesis and hybridisation. Materials, previously presented in a way that emphasised discreteness, bleed into one another and knit together to form combined and new constellations. The significance of this is it places, at least in theory, the relationships between the materials (the way they relate) in a very dynamic state of flux and infuses the landscape with constant potential for recontextualisation. Connection plus evolution. In experience, I imagine this as sensing the objects as being in motion in some way.

In contrast to the inconspicuous arrival of the second landscape, the emergence of the third landscape is very abrupt and unmistakable. In b.204, a completely homogenous landscape comes into play. A single material-type (G), previously unheard, inhabits the landscape turning around and in on itself. It is infused with all the other material-types, in different ways and to different degrees. With each repeat of the seven-bar frame it is subjected to various recontextualisations through abrupt shifts in the degree of simultaneity between the four interlocking parts of the composite texture, which in turn shifts the intervallic constellation playing out on the surface. In other words, aspects of the inherent shifting within the material are brought to the surface. Unlike the previous landscapes, a sense of discontinuity arises from within the material itself. The flute seems to act as a kind of ictus that might facilitate perception of the shifting patterns within the string harmonics. An overtly linear process of fragmentation is offset by discontinuities. Interestingly, at the end of a piece of music time typically slows down or suspends and moves into a kind of expansive space; the presence of an overtly linear process at the end of YX turns this paradigm on its head.

This broad-brush overview of the global landscape hints at differences in the way the materials are presented at a local level. This is worth exploring in detail because it is intertwined with form; specifically, the idea of form as an acquired sense of paradox which emerges from a kind of tension between what the music suggests, or we infer, in the moment and the impression we have of it with time. To embed the possibility of this sense of paradox within the music, in this case continuity concealed within discontinuity, I worked with and presented the materials in a very specific way. Working in a way akin to assemblage, I selected instances of the material-types to present in alternation. In doing so, I intended to lend to each material-type a quality of discreteness and engender stark shifts. This means the way the music presents in the moment could be described as fragmentary with frequent stops and starts and striking contrasts between one moment and the next. These contrasts are embedded within the music because of disjunctions in attributes between adjacent instances, which are sometimes emphasised by temporal gaps. The presence of these embedded disjunctions suggests that the way we feel the music unfold from one moment to the next might be characterised by discontinuity and disorientation. This kind of situation might look something like this:

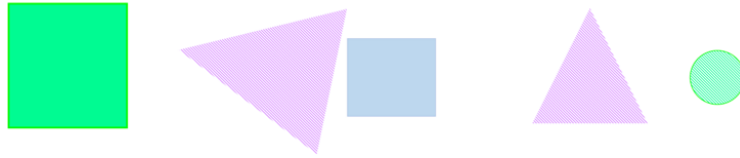

Looking at this illustration, I wonder, do you notice anything that you missed or mistook at first glance? Alongside suggesting discontinuity, stark juxtapositions have the potential to conceal qualities which instances share. Shared qualities typically suggest continuity and coherency. These two aspects – disjunction and connection – are both embedded within the music, meaning they are at play simultaneously. However, the shared qualities, suggesting continuity, are *concealed within* discontinuity. By this, I mean that they are operative within different layers. Stark juxtapositions (disjunctions), in theory at least, have the capacity to position qualities instances might share, and the way these relationships evolve, just below our immediate radar. Just beyond the point of immediate graspability. In contrast to this sub-surface, aspects operative at a surface level are immediately apparent or graspable in the moment. This idea of surface and sub-surface differences plays with our limited capacity to grasp onto and consciously attend to things in the moment. Where there are things in play that lend themselves to being immediately noticeable, like contrast, those things that need more time or a greater level of attention to be grasped or latched onto are inevitably missed or mistook in the moment. In a sense, the sub-surface aspects, in this case shared qualities, refers to those things that we have a delayed awareness or comprehension of. It is this delay effect that, in theory at least, has the potential to lend to the listening experience a sense of paradox. In addition, this kind of situation where things are infused with different weights of graspability and only select things are brought into focus (i.e. juxtaposition based on presenting a selection of the total field to the listener) lends itself, in theory, to a kind of listening experience where a listener is not led from one thing to the next but encouraged to feel their own way.

### 2.2.5 Form (as experienced)

I have listened to *yx* many times recently. Sometimes back-to-back. Sometimes with a brief interlude between hearings. Sometimes a long interlude. There is a reason for this. Its premiere left a lasting impression on me. A sense of misalignment or gaps, chasms even, between making and listening. A mismatch between my expectations as the artist about how form might play out and how we might feel time unfold, and my experience of these things as a listener. This sense of misalignment seems to emerge through two or three aspects of the global

landscape. After repeated hearings, these aspects consistently linger in my memory. They correspond with my initial experience and impression.

In listening, I initially feel struck by a sense of fragmentedness. Discontinuity. A sense of contrast within the shifts from one moment to the next. It feels disorientating. I sense a need to actively find something to 'hang onto'. A thread of some kind. Things feel like they are in motion. However, through time my impression changes. I feel the landscape changing and shifting but the objects feel static. I feel the objects vary and change context. But I feel no sense of motion. Instead, I feel its absence. I think this interferes with my listening. I feel like I gradually lose the sense of needing to actively find something to latch onto. Once I find a thread, a sense of shared identity perhaps, it feels like the objects lose their initial kind of dynamic quality. I think I cease to notice identity after a while.

My sense of discreteness and connection in experience is different to my expectations as the artist. Different to what the abstract score suggests. The sense of discreteness I experience within the shifts from one moment to the next does not feel as stark or jarring as I expected and intended. Disjunctions are present but they seem to lack a certain kind of weight in the moment. A kind of immediacy. Potency. I seem to grasp some disjunctions immediately, such as –

The image shows a musical score for measures 5-7. The score is written for five instruments: flugelhorn (fl), piano (pno), violin (vln), clarinet (vc), and double bass (Db). The time signatures are 3/4, 7/4, and 4/4. The score includes various dynamic markings and performance instructions. The flugelhorn part starts with a 'silence' and then plays a melodic line with an 'edgy metallic tone' and a 'ppp' dynamic. The piano part has a 'silence' followed by a 'mf' dynamic. The violin part has a 'silence' followed by an 'arco ord.' instruction and a 'ppp' dynamic. The clarinet part has a 'silence' followed by a 'pppp' dynamic and a 'flaut senza vib.' instruction. The double bass part has a 'silence' followed by a 'pppp' dynamic and a 'flaut' instruction. The score also includes a '(Sost. Ped.)' instruction for the piano part.

Figure 2.10: bb. 5 - 7

The musical score consists of four staves: flugelhorn (fl), piano (pno), violin (vln), and double bass (Db). Above the staves, time signatures are indicated: 3/8, 7/4, 5/8, and 5/4. The flugelhorn part starts with a 'silence' in the first measure, followed by a triplet of eighth notes marked 'edgy metallic tone' with a dynamic of *pppp*, then a single eighth note marked *mp*. The second measure is a 'silence'. The third measure is a 'silence'. The fourth measure features a triplet of eighth notes marked 'normal and alt' with a dynamic of *ppp*, followed by a single eighth note marked *pp*. The piano part has a 'silence' in the first measure, followed by a half note marked *mf*. The second measure is a 'silence'. The third measure is a 'silence'. The fourth measure is a 'silence'. The violin part has a 'silence' in the first measure, followed by a triplet of eighth notes marked *pppp*, then a single eighth note marked *mp*. The second measure is a 'silence'. The third measure is a 'silence'. The fourth measure features a triplet of eighth notes marked *ppp*, followed by a single eighth note marked *ppp*. The double bass part has a 'silence' in the first measure, followed by a triplet of eighth notes marked *pppp*, then a single eighth note marked *mp*. The second measure is a 'silence'. The third measure is a 'silence'. The fourth measure is a 'silence'. There are also performance instructions like '(Sost. Ped.)' for the piano and 'III ST+ e flaut' for the violin.

Figure 2.11: bb. 20 - 23

But even these lack a certain kind of...resonance, perhaps. With others, it seems like I have a kind of delayed awareness of their presence. It feels like the distinctions are not as perceptually salient as I expected and intended. In contrast, the connections feel *more* perceptually salient than I expected. I think this might be interlinked with my sense of a misalignment between the ways the materials appear to relate in the abstract score and how they relate in experience. Perhaps the connections that I was trying to tease out from one module to the next were not sufficiently strongly projected. Overall, it feels like the material-types relate far more than I intended and expected. I think this means that the sense of discontinuity from one moment to the next acquires a different kind of weight. A different kind of presence. A shift in balance between discontinuity and continuity or the degree to which one seems to be concealed within the other. The kind of sense of paradox I acquire. I think the way I experienced the relationships between the material-types as a listener might look something like this –

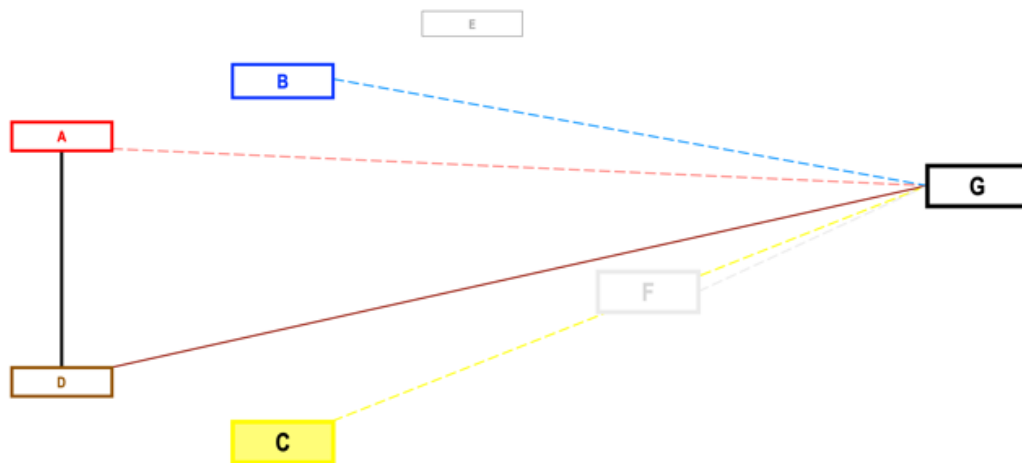

rather than –

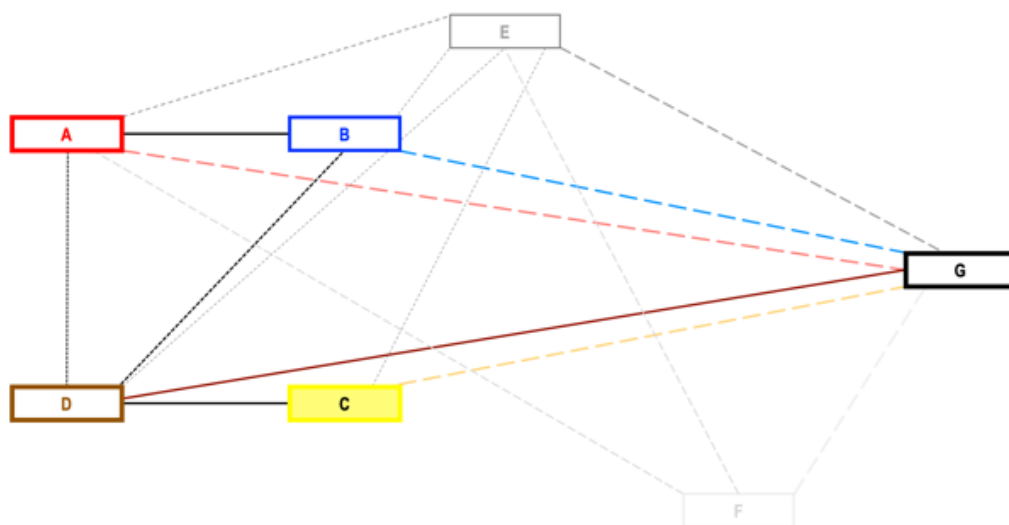

The final gap to mention is not a gap between making and listening. It is a gap between different encounters within listening. Two kinds of encounter with material-type F that seem to translate into very different retrospective impressions of form and temporal unfolding. I recall of the first time I encountered this material-type in listening a feeling of jarring abruptness and starkness. A sense that it was the wrong kind of contrast. Too much contrast. Or both. It seemed to introduce into play a kind of negative recontextualisation. Engender a sense of negative perspective. It felt like it had the effect of altering my perspective of all that precedes it by smudging or removing the lines between the other material-types. Everything felt flattened and devoid of contrast. It interfered with my (active) listening and with my capacity to grasp very fine details. I had become attuned to the subtle details of the other material-types prior to F's arrival into play in b.70. Its presence shifted my attention away from these details and reduced my awareness of their differences. It absorbed my attention. Everything else felt paled and

seem to just pass by. Encountering F again recently however, my impression of it feels very different. It appears to have fine gradients of detail, subtlety even, embedded within itself. Through time these details seem to intensify the subtle differences embedded within the other material-types. As I become aware of these qualities, F seems to acquire the sense of being a bridge of connection with other material-types. With this encounter, as the third landscape emerges and unfolds, I find myself wondering how I can arrive somewhere that feels strikingly new, yet familiar in some way at the same time.

### 2.2.6 Reflections and Insights

I recall a sense of being surprised by these gaps. For three reasons, I think. Their mere presence. Their prevalence. But perhaps most significantly, their implications for form. For a temporally projected sense of continuity concealed within discontinuity. I can still recall, even feel, the potent sense of frustration, disappointment, and dissatisfaction these gaps engendered. The restlessness and intense need to understand why they emerged. My sense is there are three key reasons.

There is extensive variation within the individual material-types. But there is little or no change in the way the material-types relate. There is an absence of connection *and* evolution. This is evident in a map of the global architecture I made shortly after the work's premiere. It shows how shared qualities, within the domain or pitch and interval, unfold over the duration of the piece between material-types A, B, C, and D. It maps out a selection of landmarks where a cluster of changes occur.

# Overview of Abstract Form

Recontextualisation

- Shared Characteristics**
- Pitch
  - Pitch class
  - Pitch and pitch class
  - Interval
  - Interval class
  - Interval and interval class

**B.1 – 77**  
Diverse landscape of independent constellations

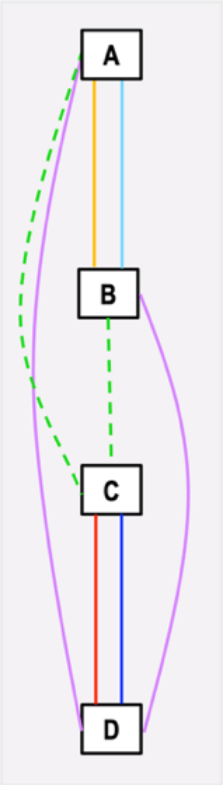

**B.78 – 203**  
Diverse landscape of overlapping materials and composite constellations  
Relationships in a constant state of flux through recontextualisation and hybridisation

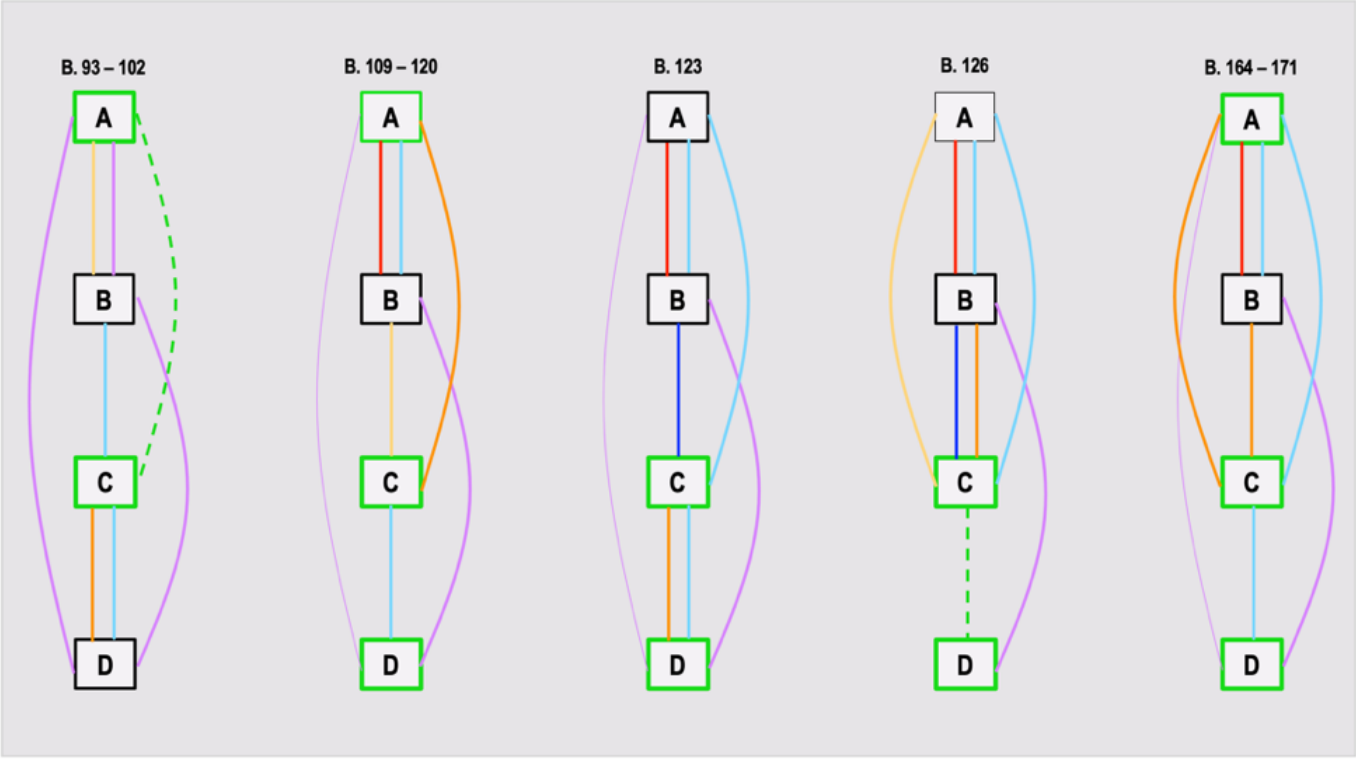

**B.204 – 301**  
Homogenous landscape

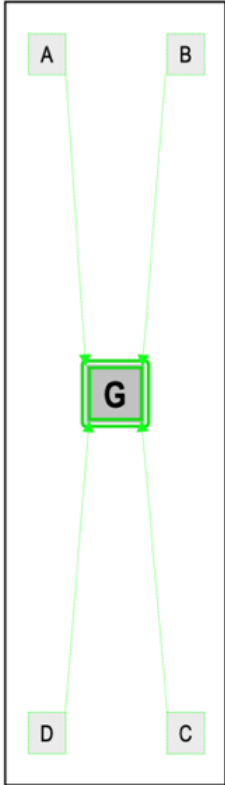

Figure 2.12: Overview of abstract form

This absence of evolution applies to mechanisms of connection and the pitch material itself. This is highly significant. Without evolution (a change in the way materials relate) the discrete objects cannot be experienced as being in motion. I think this sense of motion, of things being in a state of flux, is pivotal for acquiring a sense of continuity in retrospect. A sense of paradox. For experiencing form as something that slowly falls into place within the act of listening. I think a certain kind of dynamism is inherent within this impression of continuity and form. I think this sense of dynamism within the way things relate, of evolution, is pivotal/vital for engendering active listening or a kind of heightened listening attention.

Interlinked with this absence of evolution, is my reliance on Gestalt principles of similarity and identity only for embedding connections within the music. In hindsight, these kinds of principle of connection feel inherently limiting. As the landscape of *yx* unfolds, I think they lose their sense of resonance. I cease to notice them. I wonder if this might be related to the way they interact with my memory and attention. Something about the way, or degree to which, they impress upon me a need to feel my own way around the space. Perhaps they lose my attention. Perhaps they do not challenge my memory sufficiently to hold it. I wonder too, if the impact of these principles of connection were weakened by my equating pitch class and pitch. Pitch, in stark contrast to pitch class, encompasses register and contour. It acknowledges the context in a way that pitch-class does not. This feels like a significant insight given the nature of the kind of musical situation I am exploring.

Entangled with the absence of connection *plus* evolution and connections based on similarity and identity, is a third thing. Perhaps the most significant of the three reasons for gaps. It is the degree of flexibility embedded within the abstract form itself. Or, perhaps more aptly, the absence of embedded flexibility. Fundamentally, this is about the nature of the relationship between materials and form. Form *before* materials. I think this infused the relationship between the material-types with significant rigidity and fixedness. I wonder if working with form *before* materials encouraged me to define the characteristics of the material-types to a particularly high degree before knowing them. To almost embed fixedness within the concept of form itself. In a sense, I was forcing materials to fit the abstract form. I wonder how this situation might have played out if I had held in mind something more like Wittgenstein's family resemblance. I think intertwined with this sense of rigidity and fixedness embedded within the abstract form are the kinds of differences I worked with. The discreteness of the material-types is primarily embedded within subtle details. Fine gradients of detail. I sense it is not necessarily this subtlety per se that is an

issue. It is the way it comes about, and how it interacts with its context. It is a kind of subtlety that relies on performers bringing out very fine gradients of detail, such as grains of articulation, typically through complicated means, and the listener's capacity to pick up on these in the moment. In this sense, the discrete characters or identities are not as inherent within the materials themselves as I thought and intended. Interestingly, the material-types whose characters were less reliant on these kinds of details, were more salient in experience. Material-types B, C, F, G, and to a lesser extent D, come to mind. These lines of thought feel highly significant because our sense of form is relative. It comes about through things, how those things interact and how we interact with them. In other words, how we experience form, whether it acquires paradoxical qualities in retrospect, emerges from/depends upon our encounter with the relationships between the materials and the unfolding moments. I sense this is about my encounter with these relationships as an artist and as a listener.

I think all of the things mentioned here directly relate to/or influence the way I experience the work's accumulating context in listening. A sense of gaps left. The number of gaps left for me to fill-in. The way I feel my own way around the space. The sense of paradox, if any, I acquire.

These things bring to mind one final thought. I think the underlying imprint *yx* left on my practice is an awareness of the central position the listening experience has within the act of making.

### 2.2.7 Conclusion

The act of making *yx* was about a reorientation of my creative practice. A process of exploring new ways of working that deal with form and time in a complex way. The creative process felt arduous at times. Within the shift between old and new ways of working and thinking, it seemed like my intuition had got misplaced. Or lost in translation. There was sense of rigidity and inflexibility that felt unfamiliar. The abstractness felt containing and restrictive, even stifling, at times. A barrier of some kind. I struggled to instinctively feel my way. At the time, I think I felt out of my depth. Yet looking back, my sense of these things is quite different. I feel like my relationship with the piece has changed through time. As the project's context has accumulated. The sense of theory and reality being somehow at odds has lost its 'sting', if you like. It feels like my viewpoint has changed. These gaps feel like the opening of pathways to new creative spaces. Now, as an artist, I feel indebted to these gaps.

The lasting impression I have of *yx* now is something like this –

For form to find its freedom within the act of listening, it first needs to find it within the act of making.

## 2.3 for *PlusMinus* (2018)

### 2.3.1. Introduction

*for PlusMinus* was written for Ensemble Plus-Minus and premiered on the 27<sup>th</sup> March 2018 at City, University of London. It is scored for percussion (bass drum, vibraphone, glockenspiel, and suspended cymbal), electric guitar, and violin. The overall duration is sixteen and a half minutes. My key concerns were to close the gap between the way things play out in the abstract score and in experience, and to embed flexibility and malleability within the abstract form. By this, I mean to work with an abstract form with inherent potential to be moulded through a back-and-forth type of interaction with the materials as they acquire their identities. This is intertwined with adopting a more flexible approach to the materials and their qualities and behavioural tendencies by holding in mind something like Wittgenstein's notion of family resemblance. My underlying intention was to embed threads of connection within the materials and leave gaps for the listener to fill-in in experience to find a thread. Like *yx*, I intended to do this using the principle of surface and sub-surface differences, but with a greater awareness of differences that make a difference in experience. For me, this meant making qualities more inherent within the materials themselves; embedding a very high degree of contrast within the materials using extreme changes in parameters, with the view to making their identities and discreteness immediately graspable in experience; and, embedding potential for connection and evolution within the materials by shifting away from Gestalt principles of similarity and identity towards more dynamic pitch and interval structures.

### 2.3.2. Form (Abstract)

I found a sense of an abstract form through a process of drawing on paper various ways a group of things, not yet known, might relate, and very vaguely how their relationships might become more entangled and acquire qualities through time.

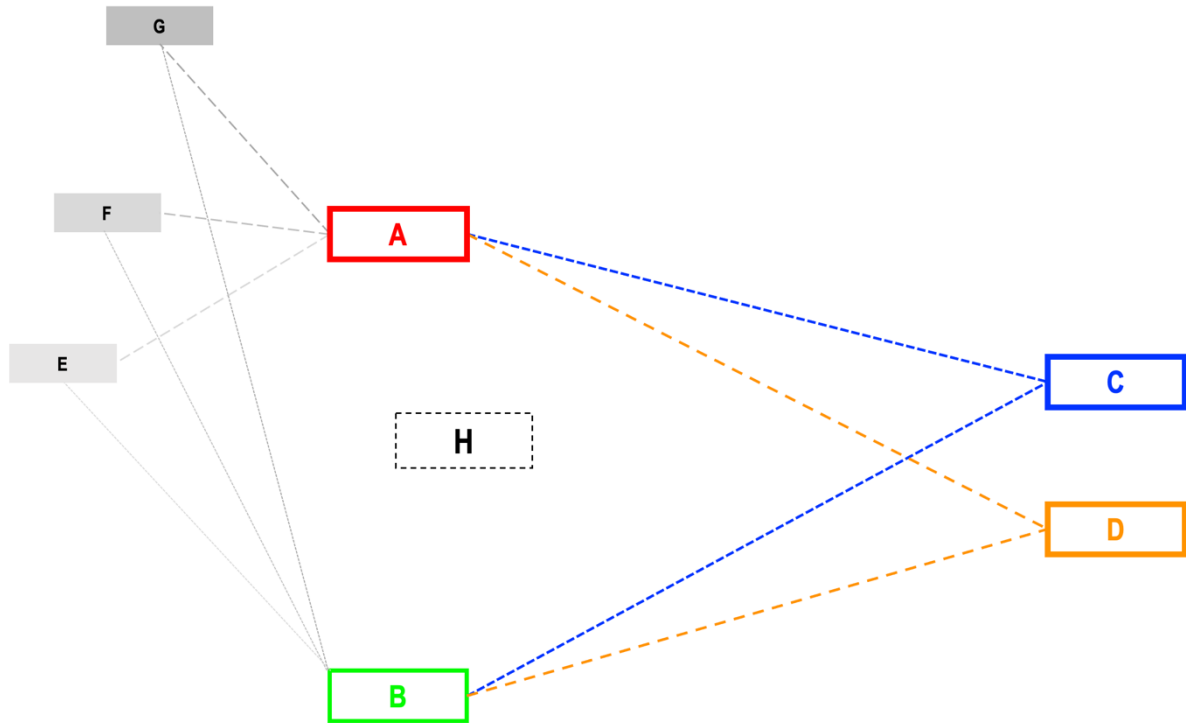

Figure 2.13: Abstract form before materials

As I set about finding my materials, this image suggested a sense of the degree of discreteness inherent within each material-type. I found the distinct configuration of material-types A, B, C, and D first. As the configurations emerged, there was a high degree of back-and-forth between the material-types; for example, one revealing a quality, or behavioural tendency, of another or suggesting an aspect of another to be changed. This dialogue continued as I searched for the variety inherent within each material-type to assemble a family of variants. I sought to respond to what the materials suggested about how they might vary and to what degree. As was the case with *yx*, the process of finding the material-types and their families of variants was quite prolonged. However, the process for this piece felt very different. It felt more intuitive, fluid, and flexible, with details of form gradually emerging as the materials revealed their qualities.

### 2.3.3 Materials

There are five primary material-types (A, B, C, D, and H). These are self-contained and have a family of non-developmental variants with a high degree of self-similarity. Rhythm is a key carrier of difference, meaning that there is stark contrast in rhythmic type across the materials. These material-types are catalogued below. The letters relate to their order of initial presentation. Material-type A explores the qualities of fluctuation and oscillation. There is wide variation in the way that these qualities are interpreted and presented. There is limited variation in

their intervallic and pitch presentation. Variants typically present as a single sustained tone, either with no specific fixed pitch content (see figure 15), as a version of A-natural (see figures 14, 18 and 19), or as a permutation of interval class three (see figures 16, 17, 20 and 21). Variants are presented in isolation or overlapped to form a more complex constellation.

4  
2

vln

1

no vibrato → fast narrow vib.

*pp*

Figure 2.14: material-type A, initial presentation scored for solo violin, b.1

7  
4  
B.D.  
soft mallets  
edge

5  
8

perc

3

→ centre

*ppp* *pp*

Figure 2.15: material-type A, variation scored for solo bass drum, b.3

7  
8

e. gtr

19

pre-bend

gliss.

*mp*

Figure 2.16: material-type A, variation scored for solo electric guitar, b.19

5 4

4 4

**Vibr.**  
motor on (very slow)  
soft mallets

44

perc

*ppp* *pp*

*Red.*

II  
flaut  
1/2 SP

vln

*mp* *ppp*

Figure 2.17: material-type A, two variations scored for solo vibraphone and solo violin, b.44

4 4

**Vibr.**  
bow  
motor on (slow)

71

perc

*pp*

*Red.*

Ⓢ  
bottle neck

e. gtr

*pp*

Figure 2.18: material-type A, two variations (overlapping), scored for solo vibraphone and solo electric guitar, bb.71 – 72

7 4

III  
II  
arco ord.

94

vln

*pp* *mp*

Figure 2.19: material-type A, variation scored for solo violin, bb.94



$\frac{5}{16}$                        $\frac{9}{32}$                        $\frac{11}{32}$                        $\frac{6}{16}$                        $\frac{5}{16}$

*Whispering, fleeting, fragile, floating*

**Glock.**  
mallets

Perc.  $\overset{5}{\text{ff}}$

E. Gr.

Vln. *flaut. ord.*

Figure 2.22: material-type B, initial presentation (incomplete), bb.5 - 9



4 9 7 4 9 7  
8 16 16 8 16 8

261  $\text{♩} = c.116$   
Glock.  
- hard mallet and metal beater

Perc.

E.Gtr.

Vln.

III  
1/2 SP → SP+

The musical score consists of three staves: Percussion (Glockenspiel), Electric Guitar (E.Gtr.), and Violin (Vln.). Above the staves, the time signatures are 4/8, 9/16, 7/16, 4/8, 9/16, and 7/8. The tempo is marked as  $\text{♩} = c.116$ . The Glockenspiel part uses a hard mallet and metal beater, with dynamics ranging from *pp* to *mp*. The Electric Guitar part features complex rhythmic patterns with fingerings (4, 3, 4, 3) and dynamics from *p* to *ppp*. The Violin part starts with a *pp* dynamic and includes a section marked 'III 1/2 SP' that transitions to 'SP+'.

Figure 2.25: material-type H, initial presentation (incomplete), bb.261 – 266

It has a very wide range of variation. It is in a continuous state of evolution as aspects combine and recombine in different ways.

There are three secondary material-types which I thought of as fragmentations of material-type A. Material-type E is scored for bowed cymbal and violin. There is no variation in pitch content, except for the natural variation within the bowed cymbal. There is very limited variation in the way the thing presents.

4  
4

188 **Susp. Cym.**  
bow

perc

vln

*ppp* *p*

I  
SP+  
arco flaut

Figure 2.26: material-type E, initial presentation scored for bowed cymbal and violin, bb.188 – 189

Material-type F is initially scored for vibraphone articulated with hard mallets and electric guitar. It has a characteristic profile reminiscent of a turn. It has a limited range of variation.

4  
4

189 **Vibr.**  
hard mallets  
motor off

perc

e. gtr

*pp* *pp*

1/2 Ped.

6:4

3

2  
4

Figure 2.27: Material-type F, initial presentation scored for vibraphone and electric guitar, bb.189 – 190

Material-type G is scored for bowed cymbal, electric guitar, and violin. A series of its variants are shown in the image below. It has a limited range of variation. It primarily varies through shifts in the degree of simultaneity between the three parts that make up its distinctive composite texture.

Figure 2.28: material-type G, a selection of variants scored for bowed cymbal, electric guitar, and violin, bb.220 – 223

### 2.3.4 Interactions Between Materials

The process of assembling this piece felt quite different to *yx*. I think this is reflected in the fluidity inherent within the global landscape. As I began assembling the piece from the matrix of variants, I had a vague sense of a kind of underlying plot based around the relationship between material-types A and B, but little sense of the global landscape. As I dwelled-and-assembled, assembled-and-dwelled, two landscapes emerged. The first landscape corresponds to bb.1 – 260. It is very heterogeneous. All material-types, except for material-type H, are in play. They rarely directly overlap and are sometimes separated by moments of latent silence. They are largely presented as discrete things forming independent constellations. The high degree of resonance engenders a certain sense of smudged boundaries. Almost like the shadow or residue of one thing becomes the backdrop for another. This has potential to lend a quality of discontinuity to our experience of the moment-to-moment unfolding of the landscape. The emergence of material-type D in b.87 is the first moment two material-types directly overlap. This seems to trigger a kind of shift within the landscape; one that we, as listeners, may not sense immediately. A more fragmentary or broken surface. Shifts between different material-types are more frequent. The duration of each instance seems to contract and the degree of latent silence between events lessens. I sense a kind of bittiness. It feels like the landscape acquires a heightened sense of dynamism. The degree of variation within each material-type and within the landscape intensifies. I sense the mechanisms for connections between material-

types might feel more unstable and malleable in experience. I wonder if this will engender a more palpable sense of disorientation in experience and heighten our listening attention or intensify the demands on our memory.

This landscape seems to be a kind of single elongated space that shifts, morphs, and warps. In b.261 (around fourteen minutes and ten seconds), a highly distinctive landscape emerges very abruptly. The boundary between this landscape and the first seems very clear and stark. This near-homogenous landscape, corresponding to bb.261 – 333, is inhabited by material-type H. Present for the first time, it is seemingly infused with various qualities of the other material-types and yet discretely new.

15

5 4 5 3 5 3 4  
4 4 8 8 8 8 8

253 **Susp. Cym.**  
low

Perc. *pp* *p* *pp* *p* *pp* *p* *pp*

*Vibr.*  
hard mallets  
motor on  
*p* *pp*  
1/2 Ped.

*Vibr.*  
soft mallets  
motor off  
*pp* *p* *pp*  
motor off

*rit.*

tip. ④ ③ ④ ③  
E. Gtr. *pp* *mp* *p* *f*  
Bi-tone ④  
ord.  
*f*  
flaut.  
*pp* *p* *pp* *mp* *p* *mp*

IV III II I  
Vin. *pp* *p* *pp* *p* *pp* *p* *pp*  
1/2 SP

*rit.*

4 9 7 4 9 7 9  
8 16 16 8 16 8 16

$\text{♩} = c.116$

261 **Glock.**  
hard mallet and metal beater  
*pp* *pp* *p* *pp* *p* *pp* *p* *pp* *mp* *pp* *p*  
*Susp. Cym.*  
low

④ ③ ④ ③ ④ ③ ④ ③ ④ ③ ④ ③ ④ ③ ④ ③ ④ ③ ④ ③  
E. Gtr. *p* *mp* *ppp* *pp* *p* *pp* *p* *pp* *p* *pp* *p* *pp* *pp* *p* *pp* *pp* *p* *pp* *pp* *p*

III 1/2 SP → SP+  
Vin. *pp* *pp* *p* *pp* *p* *pp* *p* *pp* *ppp* *pp* *p* *pp* *p* *pp* *p* *pp* *p*

Figure 2.29: emergence of new landscape, b.261

Strikingly, the pitch and intervallic constellation is stripped bare. A single octave D-natural hovers. It seems infused with a quality of stillness yet appears dynamic too. The internal details of material-type H are continuously shifting and evolving. I wonder if this intervallic and pitch constellation emptiness and stark transparency might give clarity to the fine internal details in experience, such as the rhythmic patterning, gradients of timbre, and morphology. The first and second landscape seem to suggest different things about temporal unfolding. The latter is more like a single elongated present. It lacks the seemingly stark fragmentedness of the first landscape. There are sporadic interruptions to material H's unfolding via moments of latent silence and interjections of material-type G. But I wonder if these might feel different to the first landscape. Almost like we might retain an awareness, a kind of lingering palpable trace, of material-type H. Perhaps as a kind of halo around the fleeting instances of material-type G and a certain weight within the moments of interjected silence. I wonder if this landscape might be like being given a moment to breathe, an opportunity to dwell and linger within the space in-between memory and moments.

The way the materials are presented at a local level in these two landscapes shares similarities with yx. I presented the materials in a very specific way to set-up a kind of musical situation with potential to lend, in theory at least, a sense of paradox to the way we experience time in listening. During the creative process, my thoughts were occupied with a particular kind of acquired paradoxical sense and how to embed the possibility of it within the music itself. I have called this paradoxical sense *Directed Nonlinearity*. This is a kind of temporal paradox that might emerge from a sense of tension between moment-to-moment unfolding and retrospective impressions. In experience, I imagine it as a sense of time's unfolding that shifts from discontinuity and disorientation to something resembling continuity. Nonlinearity is about gaps. Gaps left and gaps found. Gaps left for the listener to fill-in and gaps emerging in experience. These gaps might engender a kind of heightened listening attention and prompt a listener to actively look for threads of connection, a way to make sense of the unfolding situation, by feeling their own way around the space that the music invites them into (or the nonlinearity opens up). In retrospect, it might be experienced as a kind of sensation of directedness. I imagine it as a difference between having a sense of disparate pieces of a picture with no awareness of the whole to finding a thread or threads that connects these pieces and acquiring a sense of some kind of complete picture. I think this complete picture will be infused with a certain kind of fragility as only select things are brought into focus from the total field. This paradoxical sense, and the way it

might play out through surface and sub-surface differences, reminds me of some lyrics by Marc Shaiman and Scott Wittman from the film *Mary Poppins Returns*

...a cover is not the book  
So open it up and take a look  
'Cause under the covers one discovers  
That the king may be a crook  
Chapter titles are like signs  
And if you read between the lines  
You'll find your impression was mistook  
For a cover is nice  
But a cover is not the book.

To engender a sense of nonlinearity I selected instances of the different material-types to present in alternation. By lending a quality of discreteness to each material-type in experience a sense of stark shifts between moments might emerge. These frequent shifts, or abrupt stops and starts, from one moment to the next infuses the music's unfolding with a quality of fragmentedness. A kind of nonlinearity. I felt I had a greater sense of these contrasts embedded within the music through disjunctions in attributes. By this, I mean a more developed awareness of differences that make a difference in experience. Here, disjunctions primarily play out through things like rhythmic type, morphology, timbral qualities, and texture. These embedded disjunctions, and the sense of fragmentation they imply, suggest we might feel the music's moment to moment unfolding as discontinuous and disorientating. The gaps left by the disjunctions might prompt a listener to rummage around in their memory to find something that that they perhaps missed or mistook in the moment, to find a thread of some kind to latch onto. Traces of threads are embedded within qualities that the material-types share. These primarily play out through the domain of pitch and interval. Unlike disjunctions, they may not be immediately apparent. The disjunctions and shared qualities might bare different kinds of weight of graspability in the moment. They are present simultaneously but depend upon different kinds of duration. Disjunctions are likely to be felt immediately. Connections are likely to be found through time. As a listener feels their own way between these two qualities it is possible that their sense of time's unfolding will shift or acquire a different quality. One that might feel contradictory. Similarly, what felt disjointed, discontinuous, and nondirected might acquire a certain sense of connection, continuity, and directedness. A kind of emerging fragmented linearity.

### 2.3.5 Form (as experienced)

Listening to *For PlusMinus* again for the first time in a while, I found myself writing a sort of live diary of my experience. Not unlike the way Richard Glover, Jennie Gottschalk, and Bryn Harrison capture their encounters with particular works in their book *Being Time* (2019).

The first landscape seems to gradually open up a space. It is like the music is slowly revealing itself and the space it is inviting me into. The initial things are a mix of unfamiliarity and familiarity. Within the moment-to-moment unfolding, they feel different yet related. Suddenly, I feel very disorientated; it is almost tangible. A gap, a chasm, is opened. A new thing has emerged. There is a starkness and jarring quality to its sudden presence; heightened perhaps by the preceding temporal gap. My expectations are thwarted. I cannot grasp any sense of connection. My sense of disorientation is intensified. There is something intriguing about this feeling of disorientation. It seems to have lent a certain kind of richness and dynamism to the unfolding situation. The things feel like they are in motion. I sense something is unfolding that is greater than what lies within view.

The opening extended interplay between the ethereal-like textural thing stretched-out through time and various brief agitated-like things is rife with temporal gaps and stark, jarring adjacent shifts. These heighten my listening attention. They prompt and encourage me to rummage around in my memory, to find something that I may have missed or mistook in the moment. A thread of some kind. Something to fill in the gaps. There is an incredible dynamic and rich quality to this kind of situation. As I rummage around in my memory, the music continues to unfold. Things are continually disappearing and 'reappearing', warping and distorting the traces within my memory. The very things that I am rummaging around trying to find. The context, or filter through which I am experiencing things, is constantly shifting. It feels like the relationship between moments and traces is dynamic and in a state of flux. I sense things are being recontextualised; both within view and beyond the radar of my immediate attention. I feel like I am a part of something that is in the moment of emerging.

Curiously, the things in play feel incredibly detailed and subtle; yet remarkably present.

The sudden presence of a contrary motion like thing, with a kind of melodic quality, is striking and surprising. My sense of things being in motion seems to shift in some way. It is clear and palpable. Everything is in motion. A state of flux. The duration of things seems to contract. The sense of stark contrast from one moment to the next intensifies. There is so much demanding, jostling for, my attention. I am aware that I am missing a great

deal, or at least I feel like I am missing it. The unfolding situation feels discontinuous, fragmented, and disorientating. I have no sense of where it is going nor what is happening. The form feels ambiguous. Out of reach somehow.

As a fourth kind of thing abruptly enters into play, its sudden presence heightened by a crystalline dyad expressed by the glockenspiel's penetrating mallet-struck timbre, it is as though the unfolding situation pauses/suspends or momentarily stretches out through time. There is a striking sense of bareness/emptiness and transparency to this new thing. It feels like it is allowing me to linger, just for a moment. To survey the landscape. To breathe (just about). It restores my attention. Something of these qualities, a sense of motion within stasis perhaps, seems to linger within the landscape until a stark change to the contrary motion like thing, or at least stark within the context, absorbs my attention. Curiously, I seem to have acquired an association between this fourth thing and a sense of stillness. I notice it when it emerges again. A kind of expectation. I feel like I am lingering again. Being given a moment to dwell and survey. I wonder if this sense is to do with context; an emerging relationship of some kind between this fourth thing and the agitated-like things, perhaps. Things are placed. The landscape feels infused with a sense of stillness and space. I am still disorientated, but it is like I have found, for a moment at least, a sense of orientation within my disorientation. Things are still in motion. I can feel the landscape evolving within view and out of sight, yet it does not drain my attention.

I have no sense of where I am. No conscious awareness of what the form is doing. I was not aware that I had found a thread, but I feel like I have lost it. Lost a sense of plot. The landscape feels bitty. There are so many snippets, fleeting instances. It feels like too much information for my memory and attention to cope with. There it is again – a sudden moment that restores my focus and orientates me somehow. Intriguingly, it is not the fourth thing – the arpeggiated resonant chord placed by the electric guitar – but a new thing, or at least unfamiliar in some way. A single placed bowed suspended cymbal. My attention/focus is stolen by another new thing, a kind of turn-like thing. Unlike the placed bowed cymbal, this feels very unfamiliar and jarring. Curiously, it feels 'wrong' in some way. My sense of disorientation intensifies. I have no immediate sense of how this thing relates. My mind wanders as I rummage around in my memory, actively trying to find something I have missed or mistook. I become aware that the landscape seems to have moved somewhere; I am not sure of the moment when a shift emerged, just that it has. I think it is the evolution of the ethereal-like textural thing that has brought my attention back to the moment.

The violin glissandi dropped into the texture focus my attention. They seem familiar in some way, yet unfamiliar too. There is something reassuring about their presence; I feel lost, but I am not lost.

The landscape feels very dynamic and disorientating. The turn-like thing drops in and out of the landscape. Curiously, sometimes it feels like it 'belongs' and sometimes it feels 'wrong'. It is as though I am experiencing the context as a constitutive aspect of the turn-like thing. It is like the shifting context, or juxtaposed contexts, are lending different qualities to it or allowing different aspects of it to speak within the moment and to resonate within my immediate awareness. Sometimes, it feels too kind of "I am...". The landscape continues its unfolding through a dynamic kind of interplay between various permutations of things. I have no sense of where I am or what the form is doing. Things, qualities of things, abruptly grab my attention, such as the sudden emergence of a hard mallet tremolo on the glockenspiel. I feel very lost now. Perhaps the duration is too long for the materials. Perhaps the plot *has* got lost. Or, perhaps these feelings, this sense that the plot has wandered in some way, lends a certain kind of starkness and discreteness to the sudden landscape shift that follows.

This landscape is clearly different. It feels very new, yet distantly familiar too. I've still no sense of where it is going, if it is even going anywhere. It seems to just be. Suspended. Motion unfolding within stasis. It reminds me of a pedal. I sense it should change. I expect it to change. Yet, it resolutely refuses to do so. It simply seems to pause, ponder, and continue. It leaves me disorientated yet orientated. It is strikingly transparent and empty. These qualities focus my attention in on the complexity of its internal details; details that are in a constant state of evolution. Things are repeated, yet nothing feels repeated. Quite abruptly, my attention is hyper-focused. Something that did not make sense before suddenly seems to have found its place. Acquired a certain kind of resonance. The turn-like thing. It feels like this landscape is playing with my memory and sense of expectation in quite a different way to the previous landscape, at a local and global level.

Reflecting on this live diary, something stands out. A sense of contradiction between my experience of the music from within the moment-to-moment unfolding and my impression of it, or sense of it, in retrospect. Within the moment-to-moment unfolding, I felt disorientated and confused. The things in play felt very discrete. This discreteness seemed to be inherent within the things themselves. The shift from one moment to the next felt fragmented. As the landscape unfolded, I experienced isolated moments of surprising 'clarity'. As though I had found a thread of some kind. These moments felt fleeting. There were moments of surprise and contrast that

abruptly focused my attention. Moments where I felt like the plot was lost somewhere; that the music was wandering and meandering. It was almost like the form was unsure of itself. But in retrospect, my sense or impression of these things feels very different. It is like I have acquired a sense of something resembling continuity. Feeling my own way through the landscape, it is like I have found myself somewhere that feels familiar yet new, 'known' yet revelatory. It seems like I found something along the way, a thread(s) perhaps, that I have no recollection of finding or latching onto. A sense of a certain kind of understanding seems to have emerged. A picture, perhaps. Things that felt discrete feel connected in some way. A different viewpoint, perhaps. Things that I could not make sense of in the moment seem to have acquired a sense of relationship. A sense of form. This sense has no 'thingness'. It is palpable. Yet I cannot grasp it to describe it here.

### 2.3.6 Reflections and Insights

There seems to be a sense of paradox in the way time unfolded in my listening experience. A contradiction between the way I felt time unfolding from one moment to the next and my sense of it in retrospect. It is like I have acquired a different impression of time from the accumulation of moments. Different impressions from different viewpoints. Within the moments, the way the music unfolded from one thing to the next engendered a sense of some kind of temporal discontinuity. A sense that time was unfolding in a nonlinear way. This sense was palpable over the entire duration of the piece. Yet, in retrospect it feels like time was infused with many qualities; almost like it has been many things all at once. It feels like I have been occupying and discovering time, rather than being told something. As I felt my own way around the space the music opened up, I sensed things were becoming more entangled through time. Richer, perhaps. For example, the complexity of the relationships embedded within the landscape. It felt as though threads were continually emerging, disappearing, and evolving. This lent a certain sense of inherent dynamism to the situation. Traces left behind in my memory were in constant interplay with the unfolding moments. As I felt my own way, I sensed my viewpoint or perspective was continually shifting. It feels like the enduring impression I am left with has acquired complexity through time. It is an impression that I cannot quite grasp, pin down, or describe. Yet is palpable, nonetheless. It is a sense that resembles some kind of continuity. It feels like I have acquired a sense of how the dots coalesce to form some kind of picture, so to speak. Within the increasing entanglement, I have somehow found some kind of thread or threads. A sense of time that is not quite as it first appeared. There is something about this paradoxical-ness. It feels like it has infused my

experience with a certain kind of retrospective richness and depth. A trace of resonance within my memory. This situation feels like a kind of directed nonlinearity.

There is something intriguing about the way this situation, this sense of emergent temporal paradox, plays out. The discreteness of the unfolding moments and nonlinearity seem to engender a feeling of disorientation and confusion, of things feeling dislocated. At the same time, they seem to engender a kind of heightened listening attention focused on finding threads of connection. This feels paradoxical in some way. It reminds me of the way this kind of situation seems to play with my memory *and* depend upon my memory. I think these paradoxical qualities lend a certain kind of dynamic to listening. They invite me to feel and find my own way, to direct or shape my own experience in some way. To be an active participant, a contributor. A kind of constitutive aspect of what I experience the music to be, of how I feel time unfolding.

I wonder how this kind of situation 'works'. How this simple alternation model works. I think it goes something like this –

As the seemingly discrete things were presented in alternation, I sensed gaps being exposed, left, and opened up within the shift from one thing or moment to the next. These gaps felt like changes of context. They seemed to heighten (e.g. make more intense) or expose (e.g. make known) and highlight (e.g. draw attention to) or conceal (e.g. hide) the different qualities pertaining or belonging to things. Different things and aspects of things, like shared and discrete qualities, were brought into play within the surface of the music by the shifting and accumulating context. It felt like these things suggested something that seemed to contradict or call into question what I thought to be so, such as a relationship between two things that previously seemed to be disconnected or discrete. This brings to mind the words of Merleau-Ponty, 'For every moment that arrives, the previous moment suffers a modification'.<sup>7</sup> A situation playing out in this kind of way suggests a very dynamic experience in listening. Every shift from one thing or moment to the next is rife with possibility. Possible contradictions. It feels like relationships between things, between moments and echoic traces, are '...continuously renegotiable in response to changes in...context...'<sup>8</sup>

---

<sup>7</sup> Merleau-Ponty (1965): 439.

<sup>8</sup> Hanninen (2012): 331.

The alternation of discrete things and the emergence of gaps set up an expectation of nonlinearity or temporal discontinuity. Curiously, I found myself actively trying to close these gaps, to find threads of connection between these seemingly discrete things. It is as though this simple alternation model is setting up two seemingly paradoxical things in parallel. The expectation of nonlinearity and the seeds for its subversion. As I interacted with these within the act of listening, and tried to feel my way, I think a sense of temporal paradoxical-ness emerged from within the in-between space. Feeling my own way was about trying to reconcile those things that imply nonlinearity and those things that suggest continuity. In a sense, I was actively trying to complete the synthesis of the picture through time.

It seems like the highly contrasting characters of the material-types and their families of variants lend them to being experienced as discrete in the moment when presented in alternation by engendering a sensation of jarring stark shifts within the surface aspects of the music. These stark contrasts have a certain immediacy in perception. I think it is this immediacy that infuses my emerging impression of the unfolding landscape with an expectation of nonlinearity. It is like the alternation directs my attention away from qualities embedded or inherent within the music that might suggest continuity. Positions them just beyond my immediate radar. Yet, at the same time, alternation seems to make it possible for these qualities to be known. These shared qualities seem to hold the potential to subvert my expectation of nonlinearity. It is like there is a constant interplay between gaps left and threads found. This seems to frame time as something that comes about through things, how those things interact, and how I interact with them. [This reminds me of something that Tim Ingold speaks about in his book *Lines*. He talks about paths and the significance of moving along paths. To experience a sense of 'being *somewhere*' we need to move along a path or paths in-between things.<sup>9</sup> It is within the travelling along these paths that '...people grow into a knowledge of the world around them and describe this world in the stories they tell'.<sup>10</sup> This seems to resonate with my experience of *for PlusMinus* in listening. As I found paths or threads and travelled along them in-between things, I came to sense things and to be aware of things. I think this 'world', or sense of things, is told through the story of how I experience time and form in retrospect.]

---

<sup>9</sup> Ingold (2016): 3.

<sup>10</sup> Ingold (2016): 3.

These reflections and insights invite one final thought. Something that I have come to realise as I have been writing. Within the act of making *for PlusMinus*, I thought of the surface and sub-surface differences as two discrete layers playing out in parallel. One layer unfolding through non-pitch domains and the other through the domain of pitch and interval. In listening however, the situation felt far more complex. I sense these layers are not discrete at all. They seem to mix and merge, to give to and take from one another. This realisation and emerging sense of awareness, fleetingly expressed here, feels like a pivotal moment.

### 2.3.7 Conclusion

Within the act of listening, I sensed an inherent flexibility or malleability embedded within the musical situation of *for PlusMinus*. The flow of time felt dynamic, malleable, and fluid. The sense of difference between things felt stark and embedded within the things themselves. However, I still had a sense of some kind of misalignment between abstract and experience. Oddly, it feels like this sense of misalignment is beginning to close and becoming a chasm simultaneously. I think this sense of an increasing misalignment relates to a sense of a gap of sorts between my experience of making and my experience of listening. The latter was about a gradual discovery of something through time, whereas my experience of making had only traces of this gradual discovery. I think there is a kind of tension between my ways of working and my expectations as a listener in experience. The act of making has been about working with things before knowing these things and their qualities or tendencies. Defining relationships between things unknown. The act of listening, on the other hand, is about coming to know things, discovering their qualities and tendencies, and gradually exploring these things and aspects of relationship. In a sense they are playing out in reverse. The act of making *for PlusMinus* was about form *before* materials. In contrast, my experience of *for PlusMinus* within the act of listening is more like coming to know the materials and then discovering and exploring the ways they interact and relate. Or, coming to know and discover the materials through the way they interact and relate.

### 2.4 Conclusion

At the beginning of this chapter, I framed form as something that is gradually discovered or found rather than told. Something that depends upon time to make itself known. To slowly fall into place as context accumulates. Throughout the creative processes of *yx* and *for PlusMinus*, I sensed a tension between this idea and the act of

making. A mismatch or misalignment of some kind between the way I am thinking about form and the role of the listener and my engagement with these ideas within the act of making. Within the act of listening, I expected form to feel flexible, malleable, dynamic, relative, and active. An experience akin to gradually finding a thread through time as one feels their own way. Within the acts of making *yx* and *for PlusMinus*, my engagement with form seems to have been more about something growing into itself. Materials growing into a form. Unknown things being made to fit or work with an abstract sense of something. This feels much more rigid, fixed, inflexible, and unintuitive. My awareness of this tension was particularly palpable within the act of making *for PlusMinus*. I had a sense of a growing realisation and recognition of the idea of form-finding. However, it is in the work that followed – *for serge* – that it became an actual aspect of my practice as something that happens intuitively within the act of making. This has significant implications for the way I work, for the way I think about materials, and for the way we, as listeners, might experience and assemble form in listening.

## 3. The Composition Portfolio

### 3.1 Introduction

The basic premise about how continuity comes about in my music frames form as something that is gradually discovered rather than told. In *for serge* (2018), *inside-out* (2019), and *finding a thread* (2021) this premise plays out within the act of making. This was a breakthrough moment in the project. *yx* and *for PlusMinus* tell a story of a growing sense of dissatisfaction with a misalignment between abstract concepts of form and the experience of form in listening. This sense abruptly imploded in *for serge*, by which, I mean there was a stark, and unexpected, shift to form following materials and a way of working that feels instinctive and participative. In other words, there was a stark shift in the way the basic ideas I had been developing about form play out in the music. The music that emerges out of this idea of form-finding in each of the three pieces is highly distinctive. However, they are all about a certain kind of continuity that follows more or less intuitively from a dwelling within things.

### 3.2 *for serge* (2018)

#### 3.2.1 Introduction

*for serge* (2018) is scored for solo percussionist playing one very large woodblock and two large bronze triangles. The piece was written for Serge Vuille and premiered at Café OTO London in May 2018 as part of the Kammer Klang concert series.<sup>11</sup> The overall duration of the piece is eight minutes. This intimate piece shares many qualities with *yx* and *for PlusMinus*. It deals with hidden continuities, interplays between discontinuities and continuities, and surface and sub-surface differences. However, the emergent and spontaneous nature of these qualities sets *for serge* apart. In addition, the creative process began with no specific compositional intentions; rather, a greater awareness of certain things. I had a sense from *yx* and *for PlusMinus* of a need to strip back the pool of details that define materials and events. The need to find a certain kind of simplicity. Something like differences that make a difference in experience. I think this concern is intertwined with my developing awareness of the close link between the immediate graspability of an event or a material's discreteness and our capacity, as listeners, to

---

<sup>11</sup> (<https://www.youtube.com/watch?v=t-92zUvlpss>)

register variation in experience. I think this is about a growing recognition, as an artist, of the interpenetrative relationship between working with very salient and limited things and setting-up situations that deal with form in a complex way in listening.

### 3.2.2 Form-finding

The creative process began with some concrete objects, a large bronze triangle, a very large wood block, and a selection of sticks and mallets. I spent time freely exploring these objects; their unfamiliarity lending them to a more intuitive way of working. I did not have any specific intentions as I explored. Instead, I had an awareness of being intrigued by Serge's comment, "...the triangle is everything that the woodblock is not...", and an awareness of the wood block's and triangle's synonymy with punctuation and accent. As I explored, I navigated the objects as a single space, and as I did so certain qualities gradually emerged: a dynamic space in-between the two objects; qualities suggesting an expressive potential beyond punctuation and accent; points of interaction between the triangle and wood block; and points of difference. As I explored these points of interaction and difference, 'concrete' *things* emerged. I have chosen to use the term 'thing' here instead of more conventional terminology like figure, object, gesture, and motive. The term 'thing' feels more appropriate because it seems more closely aligned with my ideas about making. With the ways I think about and interact with musical materials. I am using the term to point towards the inherent thingness of the musical materials.

These things revealed a rich in-between space with innumerable potential pathways. The evolution of the work became an act of dwelling within this in-between space and an experience of allowing the things to acquire their formal significance as I dwelled. The act of handwriting the score was a significant part of this process; of finding those things inherent within the things and responding to them. I had a sense of a kind of interplay between dwelling and working; a back-and-forth between the discoveries and suggestions arising from dwelling within the materials and my response to these. Bryson (2003) refers to this as a continual 'feedback loop' between the artist and their materials. I had a sense of going with it which in turn opened up new pathways. These new pathways yielded new discoveries to be followed, and I was once more in a position of going with it. This 'going with it' was very much about responding to my discoveries in the moment and being continually ready to adjust my course. If you like, the creative process was about the path to something (e.g. form), and this path was inherently disorientating and dynamic, and imbued with possibilities. I appreciate John Berger's description of this as an artist

feeling where to go. This intuitive and flexible approach to working and finding form was liberating because I felt as much a participant in the experience as the listener is within the act of listening.

### 3.2.3 Materials

Writing about the materials is an interesting experience. In contrast to previous pieces, the materials I worked with here were less defined, and their variations emerged in a more organic way. Hence, the following thoughts about the materials are retrospective. There are four core 'things.' They manifest in various guises via the way they interact with the three instruments and playing techniques; and combine, and recombine, in a myriad of ways. The boundaries between them are not clearly defined.

The first thing is a kind of increasing-decreasing temporal wave, with a gradual increase and decrease in pace. It has a focused quality. For example:

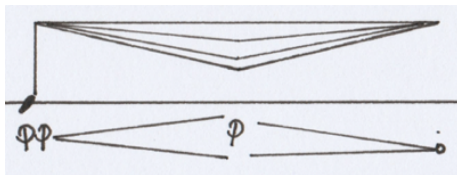

Figure 3.1: first core thing

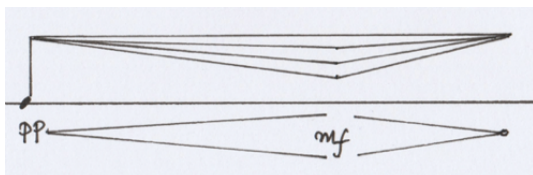

Figure 3.2: first core thing

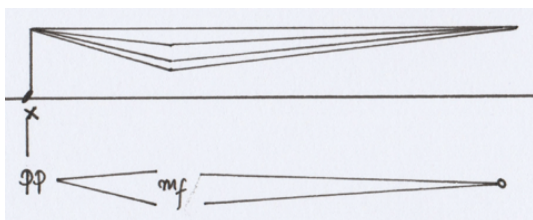

Figure 3.3: first core thing

The second thing is a kind of intensity wave, with gradual increases and decreases in intensity. These intensity changes might play out through the degree of movement across the playing surface or pressure applied to the playing surface. It is, perhaps, the explorative counterpart of the first thing. For example:

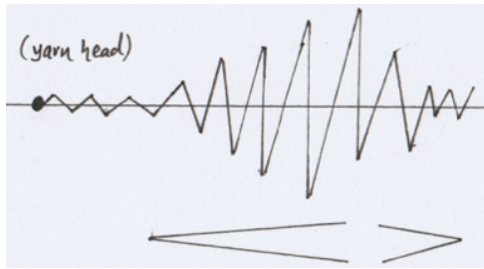

Figure 3.4: second core thing

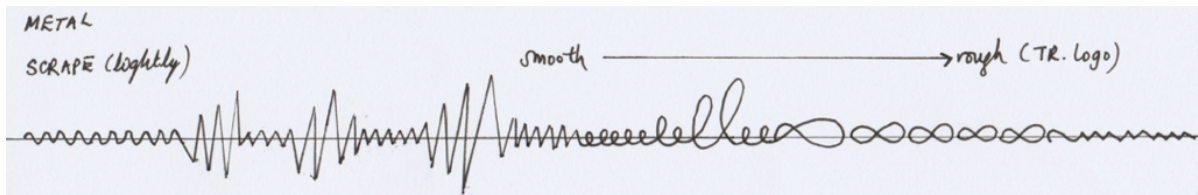

Figure 3.5: second core thing

The third thing, a kind of dislocation of the first, has a focused quality. It presents as either a gradual acceleration or a gradual deceleration of pace. For example:

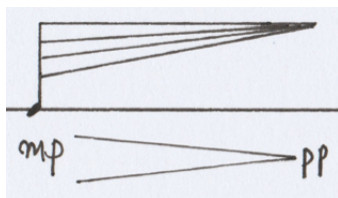

Figure 3.6: third core thing

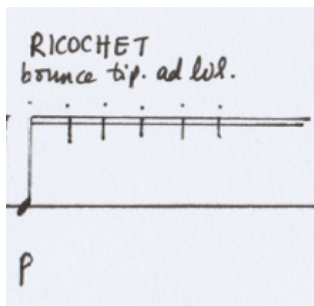

Figure 3.7: third core thing

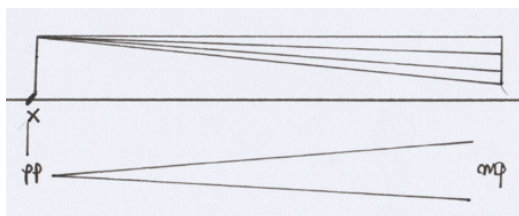

Figure 3.8: third core thing

Its potential explorative counterpart is a kind of gradual and seamless transformation of timbral quality and/or pitch cluster content. The fourth thing has various presentations, for example:

- Using hand damping pressure to gradually alter the timbral quality and pitch content of an event ('o' is undamped and 'x' is completely damped).

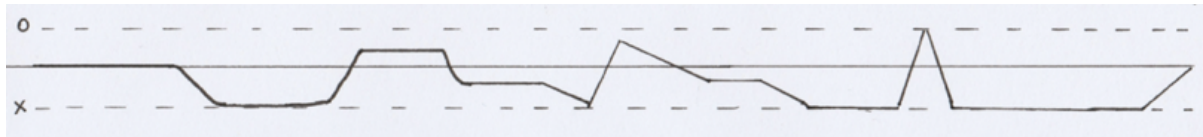

Figure 3.9: fourth core thing

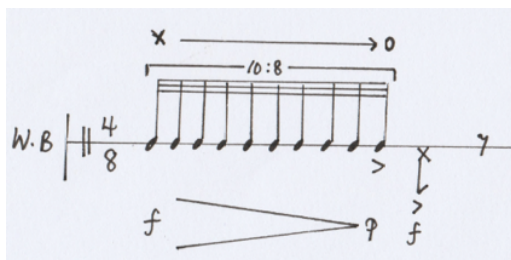

Figure 3.10: fourth core thing

- Gradually changing the point of the mallet which contacts the instrument.

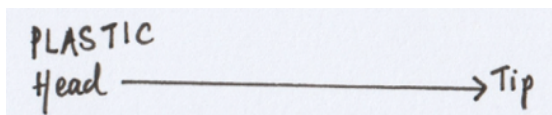

Figure 3.11: fourth core thing

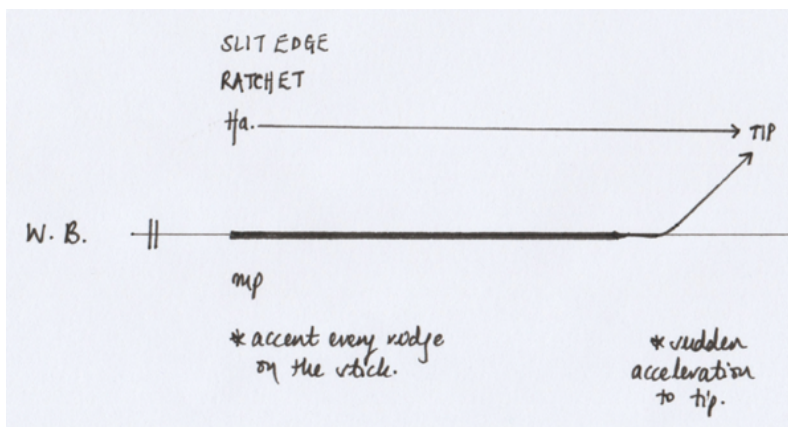

Figure 3.12: fourth core thing

- Gradually changing the playing position.

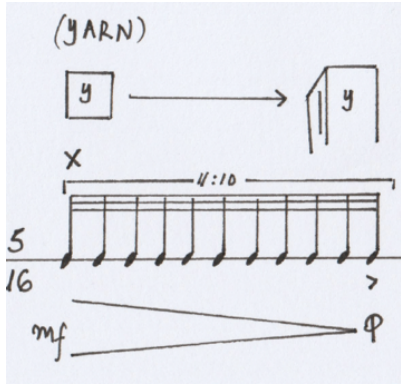

Figure 3. 13: fourth core thing

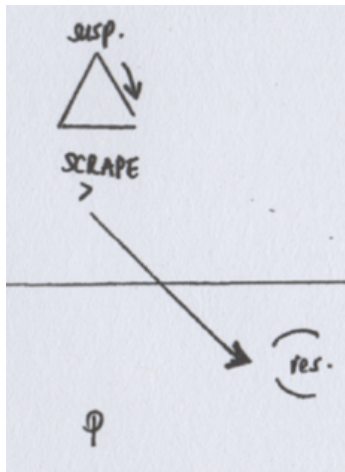

Figure 3. 14: fourth core thing

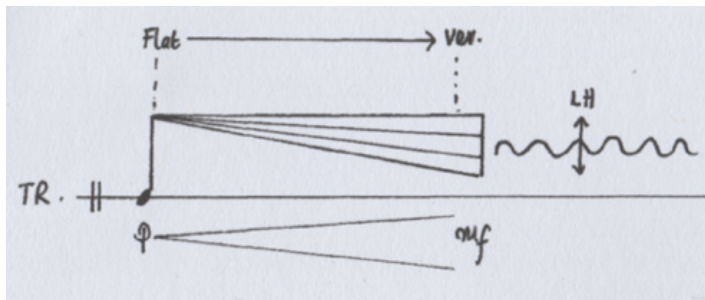

Figure 3. 15: fourth core thing

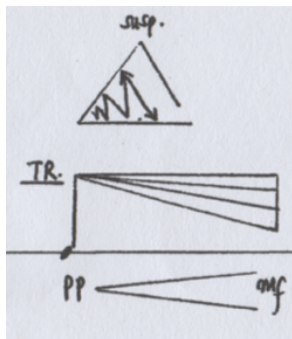

Figure 3. 16: fourth core thing

- A combination of the above.

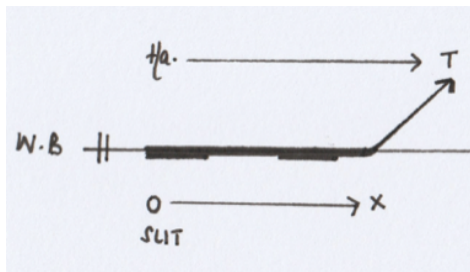

Figure 3.17: fourth core thing

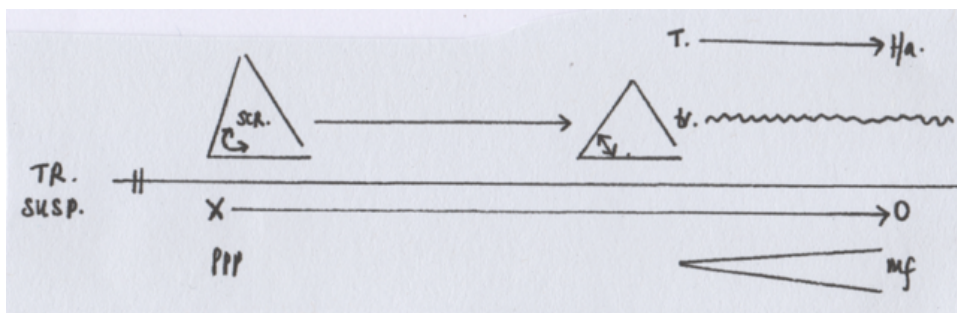

Figure 3.18: fourth core thing

### 3.2.4 Interactions Between Materials

In contrast to previous works, the process of assembling *For Serge* felt very intuitive. The matrix of variants of the four things emerged over the duration of the work's assembly as I instinctively felt my way. As I did so, and the piece evolved, a global landscape gradually emerged. This emergent landscape is a selection of the total field. Via the core things, it explores the space in-between the potentially very dry identity of the wood block and extremely resonant identity of the triangle.

The global landscape has a certain fluidity, which was absent from the landscapes of *yx* and *for PlusMinus*. A reflection, perhaps, of a more intuitive kind of assembly. I recall being very struck by this sense of fluidity and concerned about its implications for form and acquired paradoxical qualities. However, in retrospect, there is a clear sense of interplay between continuities and discontinuities evident within the score. Some of these discontinuities seem particularly stark and significant because of their pervasive nature. Every parametre of the event carries contrast within the local context. These moments suggest a potential division of the global landscape into four local landscapes.

The opening landscape is relatively heterogenous. It introduces all four things. After an initial emphasis on discreteness, their combined presentation begins to blur boundaries. Within the first eight events of this landscape, there is a clear sense of local interplays between discontinuity and continuity at play.

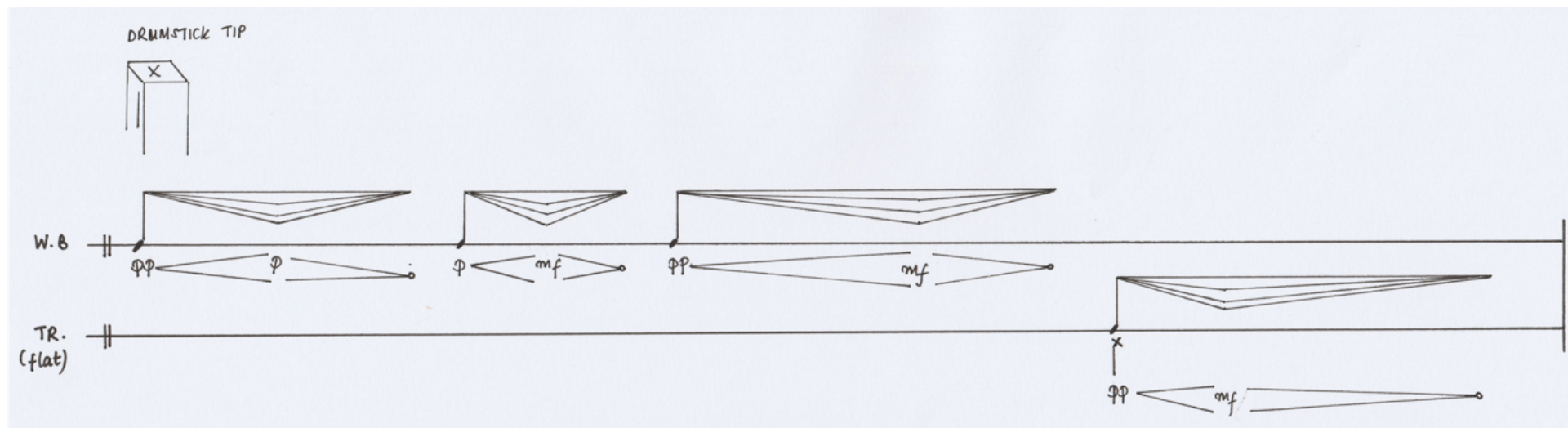

Figure 3. 19: first four events

The first three events share timbral and morphological qualities. This suggests a certain sense of continuity within the music's surface. In contrast, the fourth event shares morphological qualities only. It is a mirror-image of the third event. The long-short temporal wave becomes a short-long wave. This morphological symmetry suggests continuity. However, the disjunct in timbral qualities suggests something different. It has potential, despite its fleetingness, to lend a quality of discontinuity, or abrupt subverted expectation, to the music in the moment. This seems slightly contradictory. The timbral disjunction is deliberately contained. The triangle's discreteness is largely masked by its flat playing position on the table and use of left-hand damping, releasing just a hint or suggestion of its resonant washy-ringing metallic quality. However, the way it interacts with the local context has potential to distract attention away from the morphological relatedness. By this, I mean that it conceals it in the moment by positioning it just beyond the radar of the listener's immediate attention. There is an interesting tension here. The events are recognisably different, yet clearly belong to the same family. This suggests the beginnings of some kind of interplay and evolution of a relationship.

Looking at the next four events, similar principles play out in a different way.

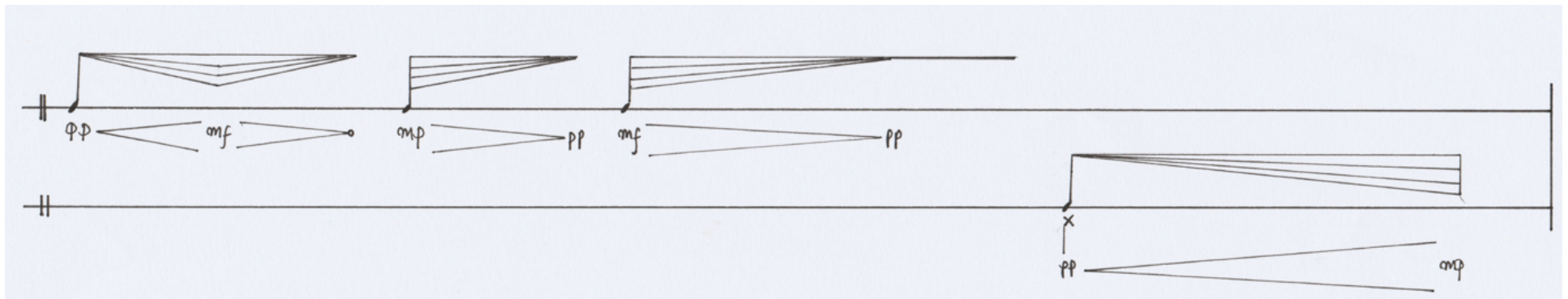

Figure 3. 20: fifth to eighth event

In contrast to the above, where disjunction plays out within a single thing, the disjunction between the fifth and sixth event arises from the addition of a new thing with a different morphology. Here, within the local context, this morphological disjunction has potential to conceal timbral relatedness. The presentation of the materials can set-up certain expectations, such as a certain kind of morphology or timbral profile, which these disjunctions potentially thwart. In experience, this might have the effect of heightening listening attention and abruptly calling memory to attention. Looking back, the interesting thing about these local hidden continuities and moments of discontinuity is their acquired quality. By this, I mean that they were not pre-planned or intentional. Instead, these local surface and sub-surface differences are an emergent property of the assembly process, and only recognisable in retrospect.

Returning to the global landscape. The first moment of weighted discontinuity manifests as a shift from relative duration to precise fixed duration rhythmic events. With this, various qualities of the wood block are unveiled.

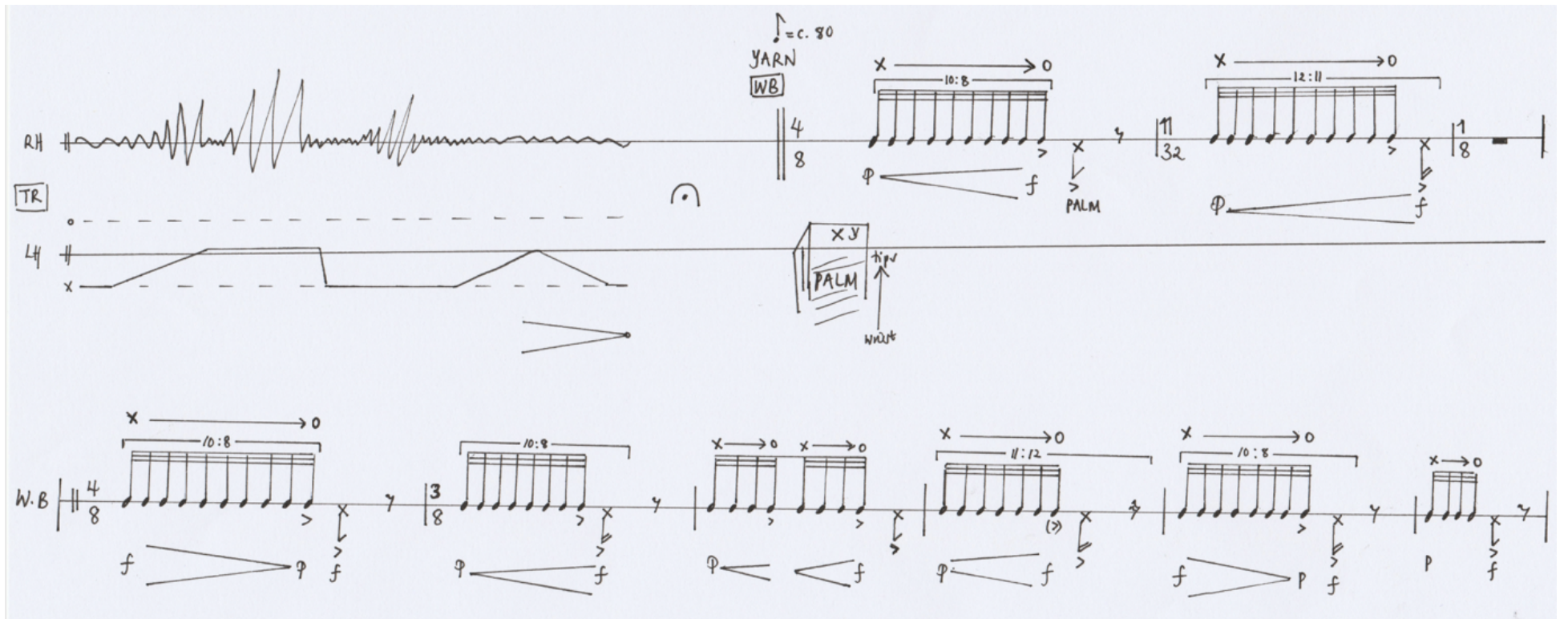

Figure 3. 21: shift from relative duration to precise rhythmic durations

The perceptual horizon seems to simultaneously widen and narrow. The landscape shifts abruptly to something more homogenous, as the fourth thing, particularly pitch content changes via hand damping pressure, becomes the focus. Various aspects of the local context lend a certain weight to this moment of discontinuity. For example:

- the use of a yarn mallet for the first time
- a shift in playing surface to the most resonant surface of the wood block
- proximity of precise metric material to explorative 'ad lib' material
- pause before
- disjunction in playing technique (scraping to hitting)
- timbral disjunction.

The very visual nature of changing a mallet or repositioning the woodblock lends these aspects a potential functional role in engendering perceptual disjunction in the moment. It feels like there is a kind of evolution in the way the performer relates to the wood block, caressing it almost.

The landscape becomes increasingly heterogenous before the ratchet stick scraped across the wood block's slit edge triggers an evolution of the landscape.

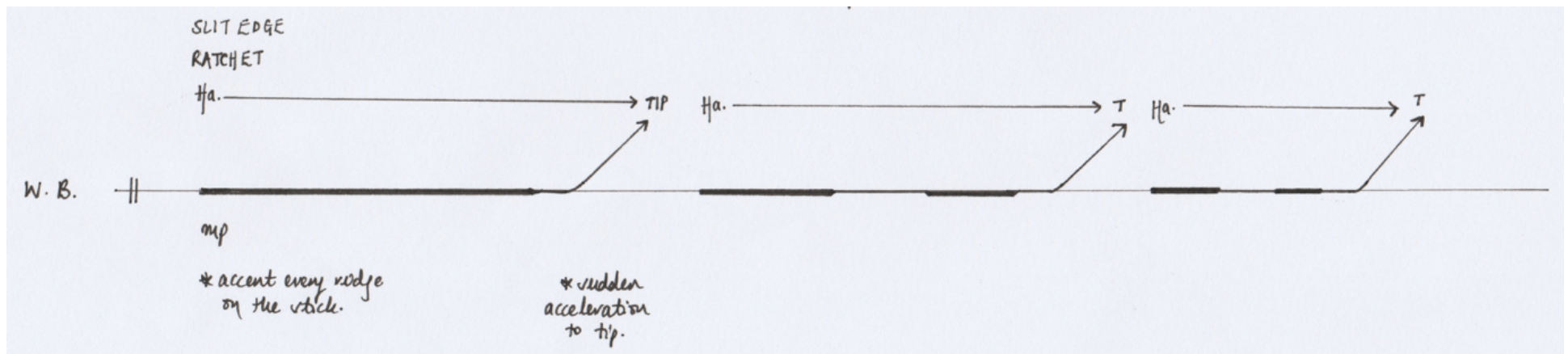

Figure 3. 22: introduction of the ratchet stick

This second moment of weighted discontinuity seems to narrow the perceptual horizon. It is the most homogenous and least fragmented of the local landscapes. An interplay between the explorative things, two and four, plays out on the ratchet sticks and wood block only. Their focused counterparts are entirely absent.

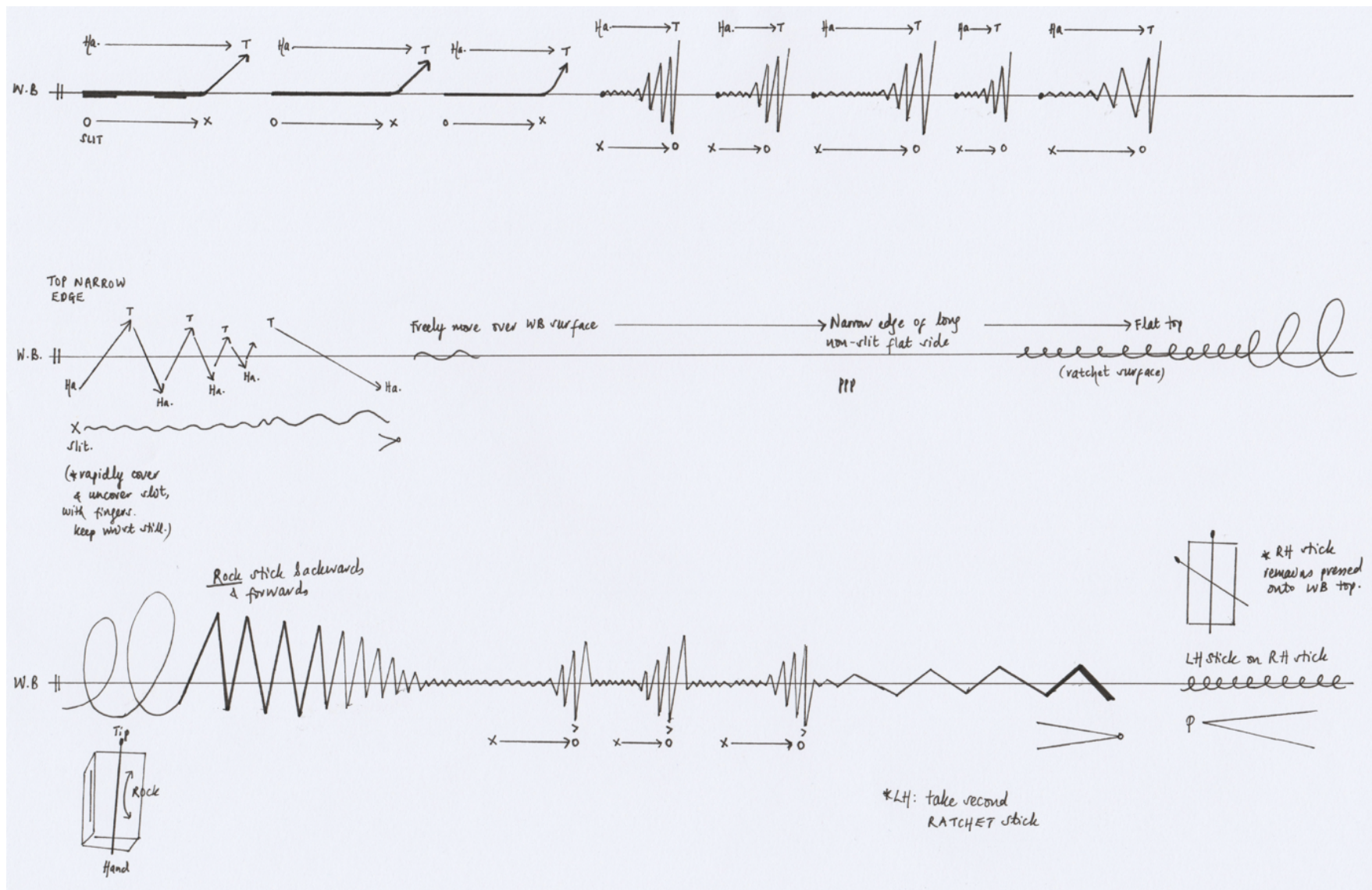

Figure 3. 23: interaction between the explorative core things

The third moment of weighted discontinuity manifests as an abrupt shift from the discrete quality of the ratchet stick on wood, and explorative nature of the material, to a landscape reminiscent of the opening articulated by a triangle.

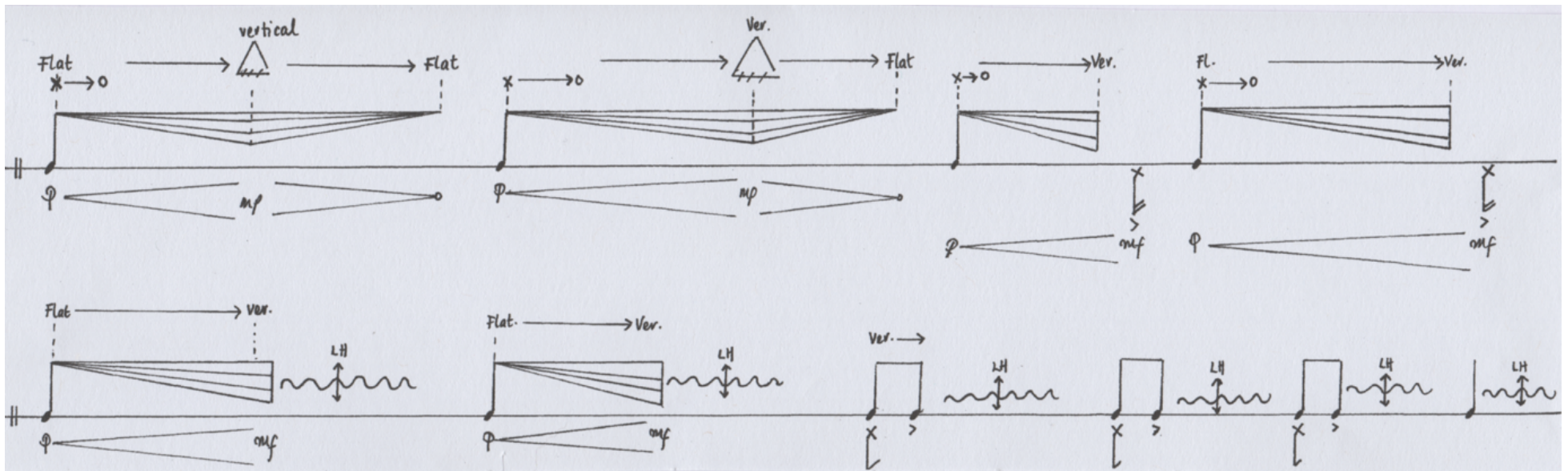

Figure 3. 24: shift to triangle

Aspects of the local context that lend a certain weight to this moment of discontinuity, include:

- relative absence of the triangle up until this point
- mallet change (ratchet stick to metal beater)
- visual act of changing mallet and instrument
- timbral disjunction
- morphological disjunction
- focused quality of the material and its temporal proximity to explorative counterparts
- disjunction in playing technique (scraping to hitting).

In addition, the landscape shifts from least heterogenous to most heterogenous. All core things are in play. Their presentation is a mixture of discrete instances and overlaps contributing to the same event. This lends a more fragmented feel to the surface and a sense of interplay between blurred boundaries and the things' discrete qualities.

The qualities of these local landscapes and sense of interplay between expectations they set-up in relation to form, seems to suggest a more intuitive awareness of the relationship between materials and context. I sensed I was feeling my way much more with respect to how materials and context interact to influence perception. Something like finding differences that make a difference in experience. The score suggests that this may have resulted in a musical situation that is more multi-dimensional than *yx* and *for PlusMinus*. By this, I mean that there is a sense of multiple interplays unfolding simultaneously at different rates across the global landscape. The kinds of interplay I am thinking about are:

- focused material and explorative counterparts
- very local-level continuities and discontinuities in morphology and timbre
- relationship between the wood block and triangles.

These interplays likely play out in different ways within the four landscapes, and to different degrees within the surface aspects of each. This hints at a fourth kind of interplay. An interplay between the local landscapes' suggestions about form.

### 3.2.5 Form (as experienced)

Listening to *for serge* again for the first time in a while, I was struck by its formal clarity. This clarity has a unique quality. I was only aware of it in retrospect. From within the interplay of unfolding moments, my impression of the form was ambiguous. There is something curiously paradoxical about this kind of situation; the way a sense of plot seems to gradually emerge and acquire a sense of resonance in retrospect only. What began as shifting discontinuities, mixing, merging, and warping in my memory, became something else. A retrospective sense of continuity, perhaps. I think the paradoxical nature of this kind of situation explains a certain sense that I had when listening. I felt that I was a part of something significant, something beyond the moment or sum of the moments. This thing seemed to be unfolding just beyond my reach in the moment, yet I was of aware of it. Not what it was, just its presence. From within the unfolding moments, the form seemed to be about tracking interplays between discontinuities and hidden continuities, and focused and explorative events. Yet in retrospect, it felt as though I had been tracking a very different kind of interplay as the global landscape unfolded. A kind of global (sub) sub-surface architecture: the emergence of the wood block and triangle as two very discrete identities. I wonder if my attention was distracted away from this by the more local-level interplays.

Looking at the first four events again, the first three events set up an expectation of continuity within the musical surface through timbral and morphological similarity.

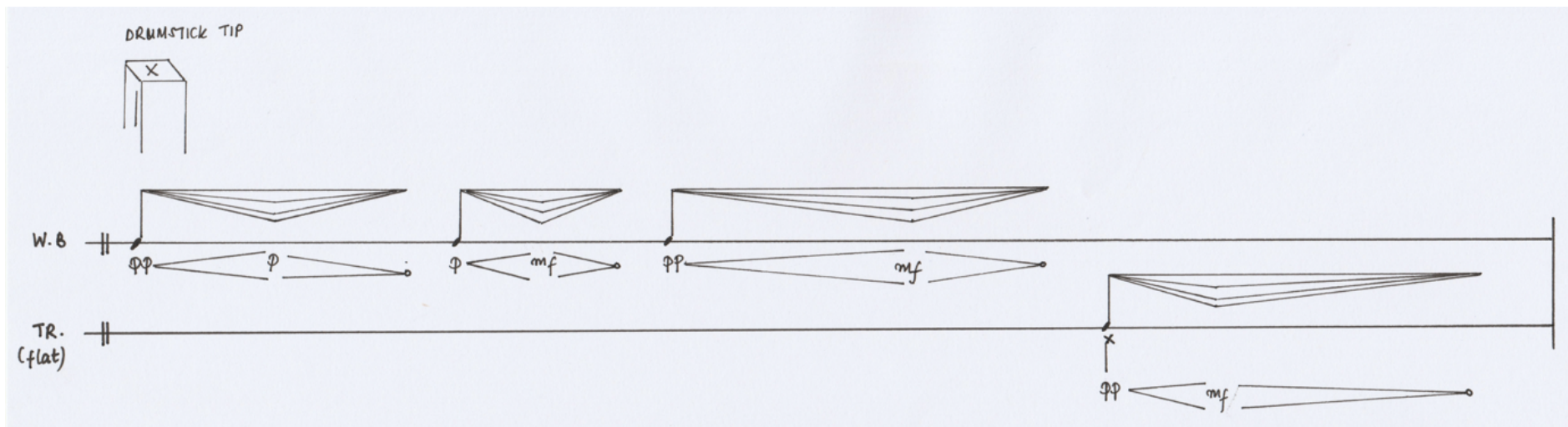

Figure 3. 25: first four events

This is subverted by the relationship between the third and fourth events. The shift prompts our first real sense of stark discontinuity within the musical surface; that is, the first moment where we as listeners ask, “what is/was that?” or “what is going on here?” I felt immediately confronted by the timbral difference, despite its apparent abstract subtlety, that the thread of morphological relatedness side-stepped my conscious attention. I feel distantly aware of a certain sense of relationship operating at a deeper level, but I cannot grasp it in the moment. It is as though this level of relatedness is hidden just beneath the radar of my immediate attention. At the same time, they seem to carry a certain weight, in the sense that it feels as though something is unfolding just beyond reach, something greater than the sum of the parts. This thing depends upon time to make itself known; the threads of relatedness gradually acquire some kind of formal significance as we, as listeners, tease out those things that we missed in the ephemeral moment.

Looking at the next four events again. As listeners, we have been led to expect a certain kind of morphology, an increasing-decreasing temporal wave.

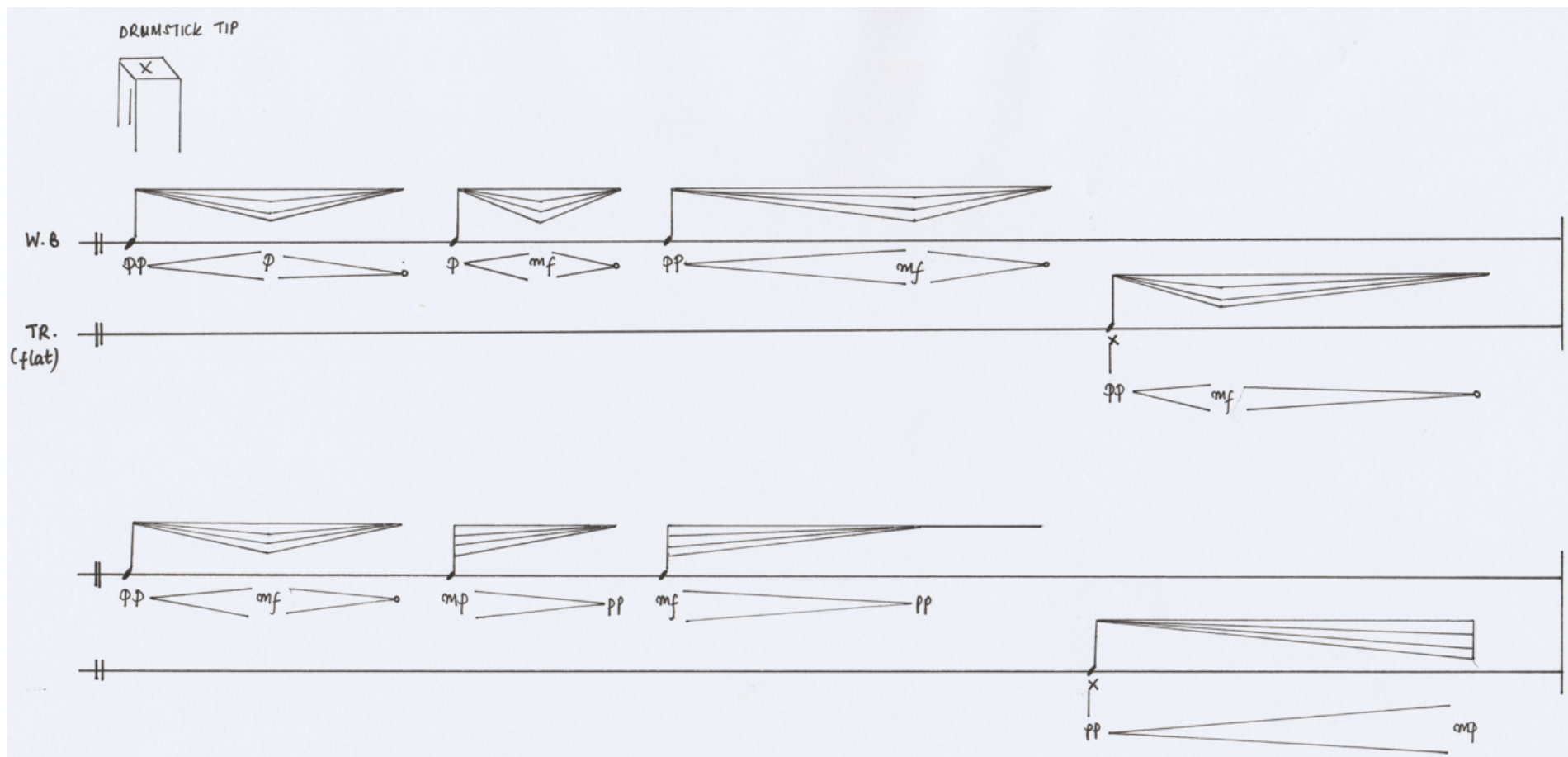

Figure 3. 26: first eight events

The sixth event presents a different morphology. On paper, it looks like a kind of dislocation of the previous morphology, as though the decreasing portion of the wave is simply being repeated. But in experience it feels strikingly different. A difference that is immediately apparent. This complete transformation of the morphological shape thwarts my expectation. The ensuing sense of discontinuity and disorientation, “what is going on?”, has the effect of heightening my listening awareness. A thread of connection or trace of continuity is still present but hidden from my immediate attention. The stark disjunct in morphology diverts my attention away from, or limits my capacity to attend to, the timbral similarity that suggests continuity. It feels like this stark morphological disjunct, like the previous timbral disjunct, forces me to question what is going on, to actively work out what I might have missed, or perhaps mistook, in the moment. It is like delving or rummaging around in my memory whilst trying to keep track of the music’s continued unfolding. In a sense, the music is inviting me to find my own path through the space it is gradually opening up, to find something, a thread of some kind, to grasp on to.

We encounter a similar situation between the seventh and eighth events. Timbral disjunction prompts an abrupt sense of discontinuity and conceals a thread of continuity through morphological symmetry. These frequent shifts within the music’s surface aspects sets up an interesting interplay between expectation, memory, and how we feel time is unfolding. Threads of relatedness, suggesting continuity, set-up micro-expectation on a very local level that are frequently subverted and in various ways. These threads of relatedness lend a certain continuity to time’s unfolding and suggest certain things about form that are then called into question. It is a kind of interplay between the moment and echoic traces in memory. This seems to engender an experience that constantly shifts between disorientation and reorientation. This kind of musical situation frames listening as a process of constant questioning.

The way surface and sub-surface differences are playing out here feels very different to the previous pieces. They are still about memory and time passing, rather than formal hierarchy. But the situation feels more dynamic and fluid. The aspects playing out on the surface keep changing. It is almost like the music keeps turning itself inside-out; a disjunct in morphology and thread of timbral similarity is followed by a disjunct in timbre and morphological relatedness (e.g. symmetry). This dynamic interplay seems to engender a more dynamic and multidimensional listening situation. It feels like the music is continually asking me to adjust and to find a sense of orientation within my sense of disorientation.

### 3.2.6 Reflections and Insights

These moments of local interplay between discontinuities and hidden continuities, and weighted landmark discontinuities that divide the landscape, and the expectations they engender and subvert, set up a dynamic listening situation. This situation is unique for two reasons. It engenders a kind of heightened listening attention and an experience of form based on assembly of discrete things from traces left in memory. Framed slightly differently, *for serge* is about being given as listeners, a new situation and having to use memory to recall a previous situation, or discrete state, to find a principle of connection, a thread of continuity. It is about picking up on, or pulling out of context, certain kinds of things. Things we might have missed or mistook in the moment. The experience of finding threads of connection, suggestive of continuity, is retrospective. In other words, connections are perceived at a distance within the traces left in memory. The process of assembling form is, perhaps, a little like doing a jigsaw puzzle whose pieces exist in memory. Finding things – threads or connections – within the interplay between moments and echoic traces is like filling in gaps. As these gaps are gradually filled-in a sense of form slowly reveals itself.

This kind of situation is about a listener finding and feeling their own way. The nonlinearity of these fragmented situations, and the heightened listening attention or awareness this can prompt, opens up a space that invites the listener to do this. How they feel their way will influence their impression of the global thing, their experience of form in listening. I think we have a sensitivity to the paradox of this kind of situation – things hidden within their antithesis, gaps left, and threads to be found – as something that lends to experience a sense of resonance and depth. There is an unfolding sense of paradox in the way that we experience form, and indeed time's passing. A sense of discontinuity within the immediate moments, of connections found within the echoic traces left behind by these moments, feel contradictory, yet in experience lend to form and time a paradoxical quality infused with resonance. This sense of form we acquire through time, these retrospectively acquired paradoxical qualities, never really takes on 'thingness' like it does in a jigsaw puzzle. It acquires a certain kind of resonance, but it is never completely graspable like a 'thing' as it is always disappearing. Its graspability is dependent upon memory. It is only graspable to the extent that we can remember and fill in the gaps. The things that we individually remember may not be the same. We may latch onto different aspects of the musical surface

as it unfolds, our echoic traces may become distorted and changed in different ways, and the accumulating context may prompt the loss of different aspects of previous context from our memories.

### 3.2.7 Conclusion

*for serge* frames continuity as an active and dynamic process; a ‘...constantly changing state’.<sup>12</sup> This sense of continuity seems relevant to the listening experience and the act of making. The striking thing about the evolution of this piece is the way I moved from a position of outsider to insider over the duration of the creative process, just as a listener does in the listening experience. This process felt very active and dynamic. Lastly, this piece left me with an enduring impression of memory as a recollection of details that is inherently fragile and vulnerable, yet capable of lending a certain kind of richness to formal experience *because* of it.

## 3.3 *inside-out* (2019)

### 3.3.1 Introduction

*inside-out* (2019) is scored for bass clarinet in B-flat, violoncello, concert harp, and grand piano. It was written for and workshopped by the Riot Ensemble. The overall duration of the piece is approximately eleven minutes. *inside-out* stands apart from *yx*, *for PlusMinus* and *for serge*, in terms of the way that the basic premise manifests. By this, I mean the way that the form acquires its paradoxical qualities over the duration of the work. *inside-out* deals with continuous phenomena. This suggests a kind of situation that interacts with memory in a very different way. This has significant implications for the way form is assembled in listening. This portfolio began with a basic premise about continuity that frames form as something that is gradually discovered or found. This process of discovery, of continuity emerging from echoic traces left beneath the surface, relies on memory, and, paradoxically, plays with the limits of working memory and attention. In addition, it frames linearity as a function of memory. This is significant. The evolution of *inside-out*, in retrospect at least, was about rediscovering linearity. Specifically, its malleability and potential for engendering a musical situation that deals, ironically perhaps, with form and time in a complex way.

---

<sup>12</sup> Takemitsu (1995): 119.

These kinds of ideas did not map directly into any specific compositional intentions. Instead, I recall a sense of heightened awareness around the interplay between memory, expectation, and attention; and ways this interplay might interpenetrate formal experience. I was curious about the different ways this could play out. How dissolving certain kinds of embedded expectation abruptly might call memory and listening to attention. The implications this might have for the way we, as listeners, experience a sense of tension or contradiction between our experience of the music in the moment and the sense or impression we have of the thing with time.

### 3.3.2 Form-finding

The creative process began with two strands of thought. Fresh reflections on the idea of *leaving gaps* and the idea of starting the creative process with no preconceived ideas. The latter happened naturally. Working with an ensemble again felt like a pivotal moment. From this viewpoint, *for serge* felt like a kind of interlude. A space, that by its very nature, had propelled my practice into a different place. Its legacy? A question. “Where now?” Reflecting on the idea of leaving gaps suggested a way forward. Gaps arise from an interplay between high levels of disjunction in the immediate surface features of the music and the connections these disjunctions conceal just beneath the listener’s immediate radar. The materials of *for serge* had an inherent simplicity that was absent from the materials of *yx* and *for PlusMinus*. In addition, the experience of *for serge* in listening had a natural dynamism and multidimensionality that was absent from *yx* and *for PlusMinus*. In other words, the simple materials set up a situation that dealt with form and time in a complex way in experience. A few things stand out here. These things opened up, or suggested a way into, a different creative space. A different kind of space for a listener to explore.

- The relationship between form and materials: working with materials with an inherent simplicity and flexibility and engaging with the principle of surface and sub-surface differences in a flexible way.
- The role of the listener in the perception of form: a departure from discrete phenomena.
- Ways in which issues of duration and scale factor in experience: a different way of leaving gaps.

These thoughts led to some very different kinds of materials. A sense of form gradually emerged from these within the act of making.

### 3.3.3 Materials

The concrete materials for *inside-out* were quite different to previous pieces. There were no pre-determined material-type configurations and variant matrices, as in *yx* and for *PlusMinus*, or core things, as in *for serge*. Instead, I had two abstract 'plots' based on very different kinds of things and found independently of each another. The first suggested how certain kinds of decomposed parametric layers might interact through combining and recombining in different ways at different points.



	1	2	3	4	5	6	7	8	9	10	11	12	13	14	15	16	17	18	19	20	21	22	23	24
<b>Sound-type/micro-texture</b>	1	2	3	4	1	2	3	4	1	2	3	4	1	2	3	4	1	2	3	4	1	2	3	4
<b>Instrumentation</b>	trio	solo	duo	trio	solo	duo	trio	solo	duo	trio	solo	duo	trio	solo	duo	Tr	So	Du	Tr	So	Du	Tr	So	Du
<b>Rhythm</b> (Aperiodic/periodic cell)	Ap	P	Ap	P	P	Ap	P	Ap	Ap	P	P	Ap	P	P	Ap	Ap	P	Ap	Ap	P	Ap	Ap	P	P
<b>Articulation</b> (Percussive, plucked, struck) (Blown, bowed, rubbed, glissando: marked or masked attack)	2	1	2	1	2	1	1	2	1	2	1	2	1	2	2	1	2	1	2	1	2	1	1	2
<b>Timbre</b> (pure/little or no overtone content/high concentration of overtones or/ noise-based)	a	b	c	d	b	a	c	d	c	d	a	b	d	c	b	a	a	d	c	b	b	c	a	d

- Presentation of the pitch material
- Line (vertical)
  - Chord (horizontal)
  - Texture
  - Static pitch

25	26	27	28	29	30	31	32	33	34	35	36	37	38	39	40	41	42	43	44	45	46	47	48
1	2	3	4	1	2	3	4	1	2	3	4	1	2	3	4	1	2	3	4	1	2	3	4
Tr	So	Du	Tr	So	Du	Tr	So	Du	Tr	So	Du	Tr	So	Du	Tr	So	Du	Tr	So	Du	Tr	So	Du
P	Ap	P	Ap	P	Ap	Ap	P	Ap	P	P	Ap	Ap	Ap	P	P	Ap	P	Ap	P	P	P	Ap	Ap
1	2	1	2	1	2	2	1	2	1	2	1	2	1	1	2	1	2	1	2	1	2	2	1
c	d	b	a	d	b	a	c	a	c	d	b	b	d	c	a	c	b	a	d	d	a	b	c

Figure 3. 27: abstract plot one

This grid is about non-pitch parameters. It suggests various ways these might combine to form kind of micro-textures, which could be used to create a complex musical situation.

The second visual 'plot' is about simple intervallic relationships. It has two aspects. A kind of middleground global harmonic design based on the division of the octave into increasingly smaller units: twelve-tone equal tempered space to forty-eight-tone equal tempered space. This suggested a way of opening out a space through a series of pitch bands or focal pitches, as a kind of sub-surface architecture, not unlike the way Scelsi does in *String Quartet no. 4* (1964). A kind of opening out of the pitch space, then a focusing in, like its imploding. The second aspect was a selection of different kinds of symmetrical interval structures that might come into play at different moments in the piece with potentially significant implications for formal perception. These are intrinsically flexible and can be mapped into different pitch spaces. For example, a structure based on equal intervallic units (e.g. [1111...]) or a wave-like structure based on gradually expanding and contracting distances (e.g. [123321]).

### 3.3.4 Interactions Between Materials

The assembly process was an experience of dwelling within the interactive space in-between the two abstract 'plots' and instinctively feeling my way. As the interaction between the plots, and myself, unfolded and evolved, a sense of form slowly fell into place. This back-and-forth process felt very fluid and flexible. There was something inherently freeing about working with these kinds of automatic processes. They facilitated an increased awareness of, and capacity to respond to, context, as I orchestrated each event or moment.

The pitch and interval architecture suggested a division of the global landscape into three local landscapes. Underlying these landscapes is a gradual fragmentation of the pitch space into increasingly smaller units and a gradual expansion of the registral space from a single pitch (C4). At first glance, this perhaps suggests an overall linear unfolding. The assembly process was about projecting a fragmented surface onto this global architecture. The idea was to position the listener's awareness of this architecture just beyond the radar of immediate attention. To set up a kind of situation where, as listeners, we are aware of its presence, but without being able to pinpoint or recognise it in the moment. A kind of distant awareness in the moment and recognition in retrospect.

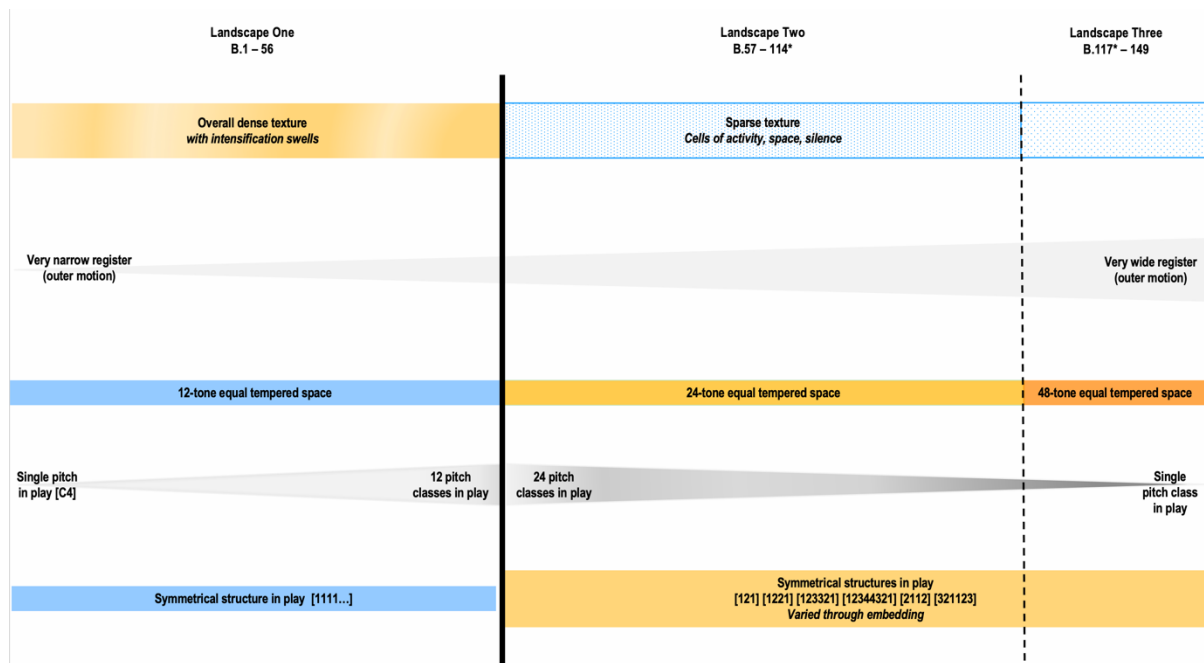

Figure 3. 28: Division of the global landscape based on pitch and interval architecture

The opening landscape corresponds to bb.1 – 56. The pitch space is divided into twelve equal tones. It unfolds via increments of a semitone. This takes place within the frame of an incrementally expanding interval, from a single pitch (C4) to an interval of 11 semitones. Onto this pitch and interval architecture, a fragmented surface is projected via continually shifting non-pitch parametric layers. Instances of different parametric combinations, as seen in figure 27, are presented with varying degrees of overlap to engender a dense texture and sense of a continually shifting wall of sound.

inside-out

Alice Jeffreys

4  
8

$\text{♩} = \text{c. } 76 - 80$   
1/2 air tone

B.Cl.

norm.  
fast and narrow vibrato

1/2 air tone

Vc.

II ST

I SP extreme

ord.  
slow and wide vibrato

Hrp.

Près de la Table

Pno.

\*damp between pins and dampers with the LH

Sost. Ped.

1/2 Ped.

Figure 3. 29: bb.1 – 5

6 norm.

B.Cl. *mp* *p* *pp* *mp* *mp* *p* 1/2 air tone

Vc. SP *p* *ppp* *mp* *p* *pp* 1/2 SP

\*gradually increase glissando speed

wide/fast to narrow/fast vib.

1/2 ST ord. 3 ST

ord. P.d.l.t. *mp* *pp* *pp* *mp* *p* *pp*

Hp. [D $\sharp$ ]

Pno. *mp* *ppp* *pp* *ppp* *mp* *p* *pp*

1/2 Ped. una corda Tre corde Sost. Ped. una corda

Figure 3.30: bb.6 – 10

1 3 4  
16 8 8

B.Cl.

Vc.

Hp.

Pno.

11

5:6

5:6

pp

mp

p

pp

narrow and slow vib.

pizz.

||

SP extreme arco

pp

mp

p

pp

fp

mf

ord.

7:6

7:6

pp

mp

pp

Près de la Table

[Et Ft]

mp

3

3

p

p

p

Sost. Ped.  
Tre corde

Figure 3. 31: bb.11 – 15

The interaction between this fragmented surface and underlying pitch space architecture seems to play out in a very different way to previous pieces. By this, I mean the way that gaps are left and the implications for tracking interplays between discontinuity and continuity in listening. There seems to be several aspects to this: duration, expectation, and memory.

*inside-out* deals with continuous phenomena in the form of certain kinds of implied motion. The symmetrical architecture of the unfolding pitch space has the potential to set up an expectation of a certain principle of unfolding. In this case, a motion of ascent. This sense of expectation, and the things it suggests about future events, develops over an extended duration, a sort of elongated moment. These kinds of expectation open up a different way to potentially engender a sense of stark discontinuity and disorientation in experience that calls memory and listening to attention. In a sense, the assembly process was about gauging the moment a listener might be acquiring a certain sense of coherence as they become attuned to a particular principle of unfolding.

The boundary between the first and second landscape, in b.57, is very clear. It is the moment that these expectations set up by the first landscape are abruptly called into question via a formal manoeuvre that subverts or contradicts them. This interacts with memory in a different way to a series of discrete moments. I think it will feel like a kind of 'Ah!' moment in listening. I imagine these 'Ah' moments as a kind of abrupt opening of a gap or shift in viewpoint, that leaves the listener to rummage around in their memory to find those things that they perhaps missed or mistook whilst keeping track of the landscape's continued unfolding. I think this rummaging around in memory will feel quite different to a situation based on finding connections between discrete things. I wonder if the way these kinds of principles of unfolding play on memory might be a bit like recalling the gist of a conversation rather than its details.

54

**D**

B.Cl. *mf* *ppp* always without vibrato

Vc. *p* *pp* *p* always without vibrato ord.

Hp. *p* *pp* *pp* bisbigliando ord.

Pno. *ppp* *p* *pp* \* hold key until the sound decays completely

Figure 3. 32: bb.54 – 61

In theory, landscape one sets up an expectation of a certain principle of unfolding. This has two aspects. An expectation of some kind of twelve-tone thing and an expectation of a certain kind of motion. Both are called into question within the shift from the first to the second landscape. The landscape abruptly shifts into a world of microtonal saturation with very different principles of motion at play. The pitch space fragments into quartertones and symmetrical intervallic waves enter into play. The impact of these two things is to effectively turn the music inside-out. The aspects previously playing out within the surface swap places with those playing out underneath the surface. In landscape one, the symmetrical unfolding of the pitch space is positioned just beyond the radar of immediate attention by the fragmented surface of shifting parametric layers. Within the shift to landscape two, the symmetrical unfolding of the pitch space abruptly emerges on the surface of the music. Except, things are not quite as they originally seemed. There is a mismatch between the thing now playing out on the surface and the thing we previously (might have) had a distant awareness of. I think this will abruptly call memory and listening to attention in experience, prompting the listener to ask, "Have I missed something here, have I lost the thread?". The form, if you like, has changed its mind about how it is working, and is leaving the listener to catch up, to fill in the gaps.

This formal manoeuvre is reinforced by various other aspects in play. The texture simplifies and acquires a different quality. The continuous wall of sound is replaced with discrete cells of activity. The interval of a semitone and its symmetrical unfolding based on equal distances is still embedded within the landscape, but it has acquired a new function and principle of unfolding. The pitch class generated by each semitonal shift acts a kind of sub-surface anchor point or axis of symmetry for the symmetrical wave-like intervallic patterns playing out within the surface of music via quartertones. These anchor points drop in and out of the texture. They unfold in a contrary-motion like way from C-natural.

9 7 4 9 4 3  
16 16 8 16 8 8

86

B.Cl.

Vc.

Hp.

Pno.

*mp* *p* *p* *pp* *p* *ppp*

1/2 SP 8:9 Pizz. arco flaut. ord. 8:9

ord. P.d.l.t. ord.

bisbigliando

[C#]

Sost. Ped.

Figure 3. 33: bb.86 – 90

3 7 4 9 7 4 9 4  
 8 16 8 16 16 8 16 8

B.Cl. *mp* *pp* *p* *mf* *p* *mf*

Vc. arco norm. *ppp* *p < mp* 8:7 *Dizz.* *mp*

Hp. *pp* *mf* *ppp* *pp* *ppp* *p* P.d.l.t. A P.d.l.t. [Cb Bb] [A#] [Eb F# G# A# D# C# Bb]

Pno. *p* *pp* *p* *mp* *pp* *p* 11 11

F

Figure 3. 34: bb.91 – 97



The symmetrical intervallic patterning playing out on the surface, around these semitonal axes, becomes increasingly varied and numerous in kind. The symmetrical waves unfold through various contours and vary through things like octave displacement and embedding (e.g. [123[121]321]). However, the number of pitch classes in play, contracts with every change of axis. This process continues through the third landscape to the end.

The boundary between the second and third landscape is blurred. A hint of a change within the properties of the landscape occurs in b.112 within the sub-surface. The distance between the pitch axes contracts from a semitone to a quartertone. A similar process of fragmentation of the pitch space into smaller units begins to play out within the surface in b.114 as eighth-tones enter into play, before an extended moment of latent silence in b.117.

9 4 3 7 4 9  
16 8 8 16 8 16

113

B.Cl. H silence

Vc.  $\frac{1}{2}$  SP  $\frac{1}{2}$  SP  
IV 8:7 SP

Hp. P.d.l.t. ord.  
[Eb Fb C#] [F# G# Ab C# B#]

Pno. 11 11 11 11 11 11 7 5  
silence H

Figure 3. 36: bb.113 – 120

As this final landscape unfolds, the boundary between the surface intervallic aspects and sub-surface non-pitch aspects seems to smudge.

The linearity that emerged over the evolution of this piece feels very different. It seems to have qualities that set it apart from the kind of linearity I engaged with prior to this project. It feels more flexible, malleable, and complex. There is a certain sense of irony here. This project began with a very deliberate stepping away from linearity and working with things with an inherent linear logic. Yet, it seems to be these very kinds of things that have the greatest inherent potential to open up possibilities for working with very stark discontinuities within the surface aspects of the music. It is like the strikingness of the linearity itself lends to the musical situation the potential to conceal itself. In doing so, it has the potential to engender an active and contributive role for the listener in their perception of form. In many ways the global journey of *yx*, *for PlusMinus*, *for serge*, and *inside-out* has brought me full circle. But from this new viewpoint, linearity and its relationship to form looks very different.

### 3.3.5 Form (as experienced)

Listening to *inside-out*, two things are striking. The ambiguity of the form. The qualities of linearity. The music opens up a space for me to explore and navigate my own way through by feeling my way. Or at least, it does after a while. The “ah!” moment of b.57 changes everything. Prior to this moment, the unfolding landscape gradually sets-up an expectation (and anticipation) of some kind of twelve-tone thing with a certain principle of unfolding. Abruptly, b.57 dissolves all sense of these expectations. The context is subverted. My memory and listening are called to attention. A gap, a chasm, has opened. I am disorientated. The sense of discontinuity is profound. Unexpected. The music is asking me to find my own way. As I search in my memory for something I missed or mistook, I try to keep track of the unfolding landscape. There is a dynamic interplay between these things. As I try to find traces in my memory, a retrospective thread, they are being continually warped, redrawn, and reframed, by the continued unfolding of the landscape. It is a dynamic situation. The music has taken me somewhere, yet I have no sense of how I came to be in the space. I do not recall being consciously aware of following a thread; if I was latched onto a certain thread, I have no recollection of what it was. Yet, I am very aware that I have lost it. I think my sense of disorientation comes from not being able to recall how I came to be in this space. My attention is heightened. My awareness of how I am listening is sharpened. My memory is challenged. I am confronted with a gap, a chasm, with no immediate awareness of how to fill it or what to fill it with. Suddenly

the act of listening is all about questioning as I try to find the thread (again). The complexity of the unfolding landscape has intensified. Various principles of motion (unfolding) are in play and their inherent logics (e.g. [123321]) are trickier to grasp and latch onto. They ask more of me, and it takes more time to find their logic. The sense of subverted context triggered by the landscape shift of b.57 prompts me to question my sense of time's unfolding; in retrospect, what seemed to be about continuity hidden from my immediate awareness by the fragmented surface was perhaps about discontinuity embedded within continuity. Curious. There is a tension between how I experienced a sense of continuity within the moment-to-moment unfolding of the first landscape, and my retrospective view or recollection of that sense.

In comparison to *yx*, the landscape of *inside-out* feels like it is in motion. This motion feels different to *for PlusMinus*. I wonder if this sense is related, in part at least, to the interaction between memory and duration (scale). The duration of the first landscape's unfolding, a kind of extended moment with an undertone of accumulating expectation, interacts with memory in a very different way to fleeting discrete moments. The vastness of the space now residing as traces within memory suggests we have to actively search more in listening and depend on memory to a greater extent.

The sense of linearity in *inside-out* feels different in quality. Previously in my thinking, linearity was synonymous with teleology and causality, a sense of time unfolding towards a specific place or goal. In contrast, this linearity feels malleable and complex, and something that encourages the listener to actively participate. Moreover, this sense of linearity in experience seems to be a function of memory. A retrospective view. A sense that I acquire. It is based on memory of past events. Echoic traces. As the landscapes unfolds, I do not have a sense of being carried along by some kind of inevitable causal trajectory. Aspects of the materials are inherently linear, and I experience a sense of unfolding logic, but I do not *feel* it as linear. Framing this slightly differently, the inherent linear logic of the first landscape's architecture sets up a situation of form-finding in listening.

Reflecting on my experience of the first landscape as it unfolds, I feel the symmetrical interval and pitch architecture unfolding in very close proximity to the surface. Much closer than I expected or intended. In hindsight, I think this is due to its very clear and simple structure [1,1,1,1,1,1,1,1,1,1]. Its logic is easily graspable. Initially, I thought this very close proximity to the surface was a 'problem'. But spending time with the music again and reflecting on my experiences of the piece in listening, my perspective has changed. The very close surface

proximity of [1111111111] is, perhaps, fundamental to my experience of the subsequent local landscapes and the global landscape. It provides a certain kind of context, which intensifies my experience of the shift into the second landscape and its unfolding. The interplay between the different kinds of logic operative within the different landscapes (e.g. [1111111111] versus [123321]) makes for a dynamic musical situation. As the music's unfolding retreats, I sense the presence of a mismatch between my experience of the stark linear logic of the first landscape in the moment of its unfolding, and my retrospective sense of it assembled from traces left in memory.

### 3.3.6 Reflections and Insights

*inside-out* frames directedness as a sensation that arises from the listener feeling and finding their own way around the space that the music opens up. Like continuity, it is a sense we acquire and experience retrospectively. These kinds of retrospective impressions, including our impression of the global thing, depend on memory. They are assembled from echoic traces left behind. When listening to music we never at any moment have access to the whole or total context. Not unlike the way we cannot see and grasp a vast Barnett Newman painting in its entirety as it exceeds the capacity of our visual field. Music is temporal. We experience it through time. Things are always disappearing, leaving only traces and gists in memory. These traces are dynamic, fragile, and vulnerable. They are inevitably distorted, changed, and reframed by everything that follows. Our sense of how things relate is in a constant state of flux. It is only through time that we can acquire a sense of resonance and depth. I think it is memory that lends these qualities, a certain kind of richness, to our impression of the global thing, our experience of form. It is the inherent dynamism, fragility, and vulnerability of memory that imbues it with the capacity to lend these qualities to experience.

In *inside-out* the basic premise plays out through subversion of expectation. Formal manoeuvres abruptly disrupt, unsettle or off-balance any acquired sense of familiarity, orientation, or coherency by changing the context. These stark context changes manifest as "Ah!" moments in experience. "Ah!" moments open gaps or expose gaps left. These call memory and listening to attention. Gaps can prompt a listener to actively look for a thread to latch onto within the interactive space in-between traces left in memory and the unfolding moments. They question our assumptions about form, suggest we may have missed or mistook something in the moment, and encourage us to actively find a thread. Framing this slightly differently, gaps reveal a sense of mismatch between our experience or impression of a thing in the moment and our experience or impression of it as assembled from traces left in

memory. This mismatch might be a sense of tension or contradiction between what we discover and infer in the moment-to-moment unfolding and what we discover from a retrospective viewpoint. As context and gaps accumulate the significance of things can change. This infuses our sense of form with a certain dynamism. It is something that slowly falls into place through recontextualisation. This process of recontextualisation unfolds until the total context has accumulated. A sense of form can only fall into place when it all exists in memory. It is a retrospective impression or view that comes about through things and how those things interact, and how we interact with them. Memory is intrinsic to this. The sense of form acquired through time is a reflection of, or emerges from, threads found within the interaction between actual moments and their traces left in memory. The threads found with this interplay between moments and echoic traces are dependent on many things. These things will be unique to each listener and specific listening experience, such as:

- Content of recollections
- How content is recalled (e.g. specifics or gist)
- Degree of clarity or accuracy of recollections
- Attention and whether our mind wandered at any point
- Whether the musical surface drained or restored our attention and concentration at any point.

The relationship between form and memory, and indeed context, has a kind of paradoxical and interpenetrative quality. Our capacity, as listeners, to process and remember the ever appearing and disappearing musical landscape is integral to our very experience of it. It plays with the limits of memory, processing, and attention, whilst being completely reliant on it. Framing this slightly differently, we discover a sense of form in context and experience context as an intrinsic aspect of what we come to understand the form to be.

### 3.3.7 Conclusion

Like *for serge*, my experiences of *inside-out* seemed to leave a question. “Where now?”

I was surprised to find myself working with linearity again in *inside-out*. It seemed to be a space opened up by a narrative unfolding beneath the surface of this project. I am distantly aware of this narrative. As I feel my way from one piece to the next, it feels like I am gradually finding the thread that underlies this project and my creative practice.

### 3.4 *finding a thread* (2021)

#### 3.4.1 Introduction

*finding a thread* (2021) is scored for bass flute, bass clarinet in B-flat, grand piano, violin, viola, and violoncello. It was written for Explore Ensemble and premiered on the 9<sup>th</sup> June 2021 at City, University of London. The duration of the work is about fifteen minutes. The title, *finding a thread*, is very significant. It encapsulates the basic premise. It points to the narrative underlying this project. The idea of finding a flexible way of thinking about form as something that is dynamic, based on relations, and slowly falls into place (emerges) within the acts of making and listening. But, most significantly, it embodies my experience as the artist. The idea of form-finding seemed to acquire a new significance here. By this, I mean it played a fundamental role in the evolution of the work. The act of making was an experience of finding and discovering the thread of the work, a sense of form, within the emerging things and their interactions over the *entire* duration of its evolution. This experience of form-finding felt different to *for serge* and *inside-out*. I had a sense or heightened sense of two premises playing out within the act of making. The basic premise *and* a secondary premise, which goes something like this: we somehow have a certain sensitivity to the paradox of a situation of coherency concealed within incoherency, or continuity concealed within discontinuity, as something that lends a sense of resonance and depth in experience.

The evolution of this work did not begin with any compositional intentions. But there were a few things that I recall being particularly curious about. The global landscapes of the previous pieces seem to set up situations in a way that engenders opportunity for a listener to gradually acclimatise. I was intrigued by what might happen if things were presented in a way that leaves a listener to 'catch up' from the initial event or evokes a sense of being 'dropped in' to something already in the process of unfolding. Something not unlike the kinds of situation playing out in Feldman's *Coptic Light* (1986) and *For Samuel Beckett* (1987). I sensed that this might engender a different kind of listening experience with potentially different implications for memory and emergent form. Thinking about this kind of situation in the context of the ensemble's instrumentation, a compositional restriction and a challenge emerged. The restriction: the entire ensemble must play an active role continuously throughout the global landscape. The challenge: to find textural shifts and stark contrasts within this restriction.

### 3.4.2 Form-finding

The evolution of *finding a thread* was a 'dynamic and temporal' process of feeling my way.<sup>13</sup> Things emerged. I dwelled within them. Listening and responding to their suggestions. New things emerged. Old things acquired and/or lost significances. I dwelled and adjusted. As I participated in a lived experience of these things as a dweller, and wanderer sometimes, I very gradually discovered the thread of the work. This thread, or sense of plot or impression of the global thing, was retrospective/known in retrospect. The creative process was about finding and following the path to something. I got lost along the way, a lot. I took many 'wrong' turns. I frequently found myself retracing my steps, but always arriving in an unexpected space. The act of making felt inherently intuitive and flexible. I was aware of a kind of continual feedback loop, or sense of give-and-take, between listening and responding, between the unfolding landscape's suggestions and my instinctive responses. The evolving thing, or emerging thread, felt intrinsically unstable. Just as I sensed I had found it, it disappeared or was called into question. The thread or threads I discovered as I dwelled seemed to depend on where I stood, so to speak. On my viewpoint.

This description of form-finding within the act of making *finding a thread* captures something of my sense of the basic premise *and* a secondary premise playing out within the creative process. My retrospective impression of composing *finding a thread* was infused with a certain kind of depth and resonance, which distinguishes it from my experience of form-finding within the acts of making *for serge* and *inside-out*.

### 3.4.3 Materials (Things)

There were no pre-determined material-type configurations. No core things. Nor any abstract 'plots'. Instead, things emerged gradually and organically. Almost like I was discovering the things and thread in tandem/simultaneously. I recall being aware of a continuous sense of back-and-forth between the emerging things and emerging form. Form always responding to the emerging things and their interactions.

The first thing to emerge was a landscape of sorts. This roughly corresponds with bb.87<sup>3</sup> – 99 of the score. It unfolded at pace in a left-to-right kind of way. The choice of pitch is related to the tuning of the open strings of the violincello, viola, and violin. The landscape has distinctive qualities. The surface is very busy and intricate.

---

<sup>13</sup> John Berger quoted in, Ingold (2010): 99.

It conceals a kind of sparseness, emptiness, and transparency. A sense of interplay between these qualities acquired a certain significance as the work evolved.

### 3.4.4 Interactions Between Things

Assembling *finding a thread* was a very dynamic process of dwelling within an emerging and evolving landscape. As I intuitively felt my way, five discrete landscapes gradually emerged. There was a degree of back-and-forth between these landscapes as they emerged. The position of each within the global landscape does not correspond with the order that they emerged within the act of making. The following thoughts are retrospective.

The first landscape corresponds with bb.1 – 51. It comprises one third of the work's overall duration. It dwells on a single thing obsessively. This thing has a distinctive asymmetrical wave-like morphology. In a basic form, it looks something like this –



Figure 3. 37: basic form of single thing landscape one dwells on

Instances of this thing are typically presented framed by latent silence. They never overlap. All instances are anchored on D4. No two instances are the same. The thing is in a state of flux. In terms of the global shape, each adjacent instance has a different dynamic-duration relationship. By this I mean that adjacent instances may peak

at different dynamic levels, or unfold through different durations, or vary with respect to both. It is possible we might experience this in listening as local contrasts in rate of unfolding. This dynamic wave-like thing is very finely detailed in terms of secondary parameters. These aspects vary with each instance. The spectral density of the decay and the microtonal hue of this spectral density are constantly shifting. The way this microtonal hue is expressed transforms as the landscape evolves via shifts in parametric focus (e.g. vibrato to timbral trills). In experience, I think this will feel like our attention as listeners is being constantly shifted towards different aspects.

The table below shows how the landscape evolves with respect to the spectral density of the thing's decay, the microtonal hue of this spectral density, and the way this hue is expressed by the ensemble.









finding a thread – global view of landscape one (bb.1 – 51)											
Instrument(s)		Evolution of the spectral density, microtonal hue, and how the hue is expressed by the ensemble									
Piano resonance		bb.1 – 19 D4 as 2 <sup>nd</sup> , 5 <sup>th</sup> partial (of silently depressed keys)			bb.20 – 30 D4 as 3 <sup>rd</sup> , 5 <sup>th</sup> partial		bb.31 – 35 D4 as 5 <sup>th</sup> , 7 <sup>th</sup> partial	bb.36 – 47 D4 as 5 <sup>th</sup> , 7 <sup>th</sup> , 11 <sup>th</sup> partial	bb.47 – 51 D4 as 7 <sup>th</sup> , 11 <sup>th</sup> , 13 <sup>th</sup> partial		
Ensemble	Microtonal hue	bb.1 – 6 	bb.7 – 9 	bb.10 – 17 		bb.18 – 23 	bb.24 – 28 	bb.29 – 33 	bb.34 – 40 	bb.41 – 51 	
	How the hue is expressed	bb.1 – 8 vibrato [timbral trills]		bb.9 – 14 timbral trills		bb.15 – 25 microtonal trills		bb.26 – 30 microtonal trills [interlocking lines]	bb.31 – 35 microtonal glissandi	bb.36 – 40 interlocking lines	bb.41 – 48 microtonal glissandi [vibrato]

Figure 3. 38: global view of landscape one, bb.1 – 51

Looking at this global view, several things stand out. The spectral density of the decay gradually increases as the landscape unfolds. In tandem, the microtonal hue acquires complexity. The way the spectral density increases, and the microtonal hue acquires complexity, plays out differently in the piano and the ensemble. In the piano, the spectral density seems to abruptly increase in b.36. In contrast, the microtonal hue changes gradually. This comes about through shifts in the partial relationship between the silently depressed bass notes and the sounded D4. With each shift, D4 acquires a more distant partial relationship infusing it with an increasingly complex hue. In the ensemble, the spectral density increases via a gradual accumulation of the number of tones in play. Sometimes the spectral density of the decay remains the same, whilst the tones in play change. This seems to infuse the microtonal hue with a certain kind of dynamic quality. These changes in spectral density and microtonal hue play out at different rates in the ensemble and piano. Shifts in the way the microtonal hue is expressed by the ensemble seem to both contrast with this and complement it. The shift from and back to a vibrato-centric expression has a circular-like quality. Within this, the way the hue's expression shifts has a certain kind of linear quality to its transformation. For example, the shift from vibrato to timbral trills. From timbral trills to microtonal trills. Overall, there seems to be a certain kind of erratic-ness to the way all three aspects unfold, both individually and in relation to one another. Together the piano and ensemble seem to create a shifting microtonal constellation around D4.

This global view of the landscape suggests a high degree of fixedness. In addition to dwelling on a single thing only, the overall register of the landscape is very narrow, with only a few placed registral breakouts, and the pool of pitches in play is limited to –



Figure 3. 39: pool of pitches, landscape one

This fixedness is significant. As the landscape evolved, a kind of interplay between very fine and dynamic gradations and striking transparency emerged. By this, I mean that there are certain kind of surface and sub-surface differences at play. As the landscape unfolds, those aspects playing out on the surface of the music (e.g. timbral gradations) present as intricate, very fine, and extremely dynamic. In contrast, aspects at play behind this very busy surface (e.g. pitch) appear sparse, bare, empty, and fixed/static. A sense of transparency and emptiness is striking. I think in experience this sense of transparency will not be immediately apparent. It will be concealed from view by the highly dynamic aspects playing out on the surface. I think it is a sense that we, as listeners, will

acquire. This suggests a certain sense of contradiction between how we might experience the unfolding landscape in the moment and in retrospect.

Working within the intersection between these two somewhat paradoxical qualities of dense subtle detail and sparse clarity/transparency sets up a particular kind of creative situation best described as navigating degrees of difference. Finding the 'right' balance of change and the 'right' kind of change for each specific moment or context was very challenging. A high degree of fixedness in certain aspects became necessary to illuminate other aspects, such as the shifting microtonal hue and its expression.

Dwelling on a single thing with a high degree of fixedness for a prolonged duration potentially has interesting implications for listening. The first that comes to mind is the way in which this landscape might play with our sense of expectation. As listeners, we might get to a point where we expect the landscape to change. The way the landscape subverts this expectation by continuing to inhabit the same space, to dwell on the single thing, might prompt a variety of responses. A sense of frustration. A sense of confusion or disorientation prompting a kind of questioning. A different kind of listening, perhaps a heightened listening attention. Our perception of the thing and how we hear inside each instance might be transformed in some way. This sense of subverted expectation might call into question what we understood the piece to be about, our sense of emerging form. The continued dwelling on a single thing might interplay with memory in a very different kind of way to situations where a group of things are in play.

The second landscape corresponds with bb.52 – 87, roughly. Within the shift from the first landscape to this landscape, there seems to be a sense of stark contrast. A gap, a chasm, is opened. I think the prolonged dwelling on a single thing will heighten this sense of contrast in experience. It may even subvert expectation. It may call into question our assumptions about form. It may prompt us to rummage around in our memory for something we perhaps missed or mistook, for something that might make sense of an abrupt change after dwelling within a single thing for a prolonged duration. I imagine this sense of discontinuity to be something like an "Ah!" moment or "hmmm" moment.

**E**

52

Bfl

*p* *pp* *p* *p* *pp* *p* *pp*

Bcl

Pno

*ppp* *mp* *p*

Sost. Ped.

**E**

Vln

1/2 SP arco flaut. *p* *pp* *p*

Vla

1/2 SP flaut. *pp* *p* *pp* *pp*

SP ex. 1/2 SP

Vc

*pp* *p* *pp*

I pizz. always let vibrate

Figure 3. 40: bb.52 – 54, shift to landscape two

55

Bfl *poco* *pp* *pp* *p* *ppp* *mp* *p*

Bcl *p* *p* *mp* *p*

Pno *p* *pp* *ppp* *p* *p* *pp* *p* *mp*

Ped.

Vln II *pp* *p* *mp* *p*  
*SP pizz.* *1/2 SP arco flaut.*

Vla *pp* *p* *pp* *pp*  
*SP ex.* *1/2 SP*

Vc *pp* *pp* *p* *pp* *p* *pp* *p* *p*

Detailed description of the musical score: The score is for measures 55-57. It features six staves: Bfl, Bcl, Pno (treble and bass clefs), Vln II, Vla, and Vc. The Bfl part starts with a 'poco' marking and uses dynamics *pp*, *pp*, *p*, *ppp*, *mp*, and *p*. The Bcl part uses *p*, *p*, *mp*, and *p*. The Pno part uses *p*, *pp*, *ppp*, *p*, *p*, *pp*, *p*, and *mp*. The Vln II part uses *pp*, *p*, *mp*, and *p*, with instructions for *SP pizz.* and *1/2 SP arco flaut.* The Vla part uses *pp*, *p*, *pp*, and *pp*, with instructions for *SP ex.* and *1/2 SP*. The Vc part uses *pp*, *pp*, *p*, *pp*, *p*, *pp*, *p*, and *p*. A Ped. line is present below the Pno staff.

Figure 3. 41: bb.55 – 57

This sense of contrast seems pervasive. Aspects playing out on the surface and beneath the surface shift. The wave-like thing is replaced by a kind of pointillistic texture and rhythmic cell. The registral field shifts and gradually expands as the landscape unfolds. The centre of gravity changes to A-natural. With this, a limited, and entirely new, pool of pitches enters into play.

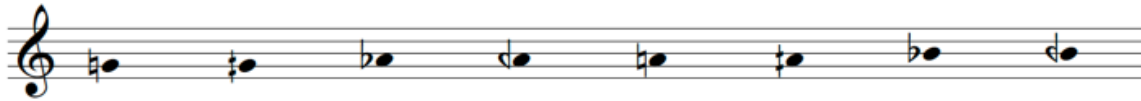

In the piano, these are mapped into different harmonic fields. These are –

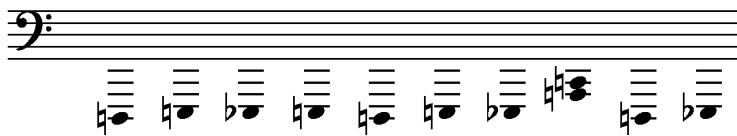

These shifting ‘silent’ harmonic fields infuse the pitches with a dynamic microtonal hue. The pitches function differently in each field, meaning their resonance acquires a different kind of hue. For example, within a harmonic field of D-natural, A-natural<sup>4</sup> acquires a twelfth partial kind of hue, and within a harmonic field of E-flat it acquires more of an eleventh partial kind of hue. Similarly, B-flat<sup>4</sup> acquires an eleventh partial kind of hue within the harmonic field of E-natural and a twelfth partial hue within the harmonic field of E-flat. This is illustrated in the tables below. They show how the microtonal hue unfolds across the landscape.

Piano's shifting microtonal hue – bb.58 – 74					
Bars	bb.58 <sup>3</sup> – 62 <sup>3</sup>	bb.62 <sup>3</sup> – 64 <sup>3</sup>	bb.64 <sup>3</sup> – 67 <sup>3</sup>	bb.67 <sup>3</sup> – 69 <sup>3</sup>	bb.69 <sup>3</sup> – 74 <sup>3</sup>
Microtonal hue					
'Silent' harmonic field	D1	E1	E-flat1	E1	D1

Figure 3. 42: evolution of piano's microtonal hue, bb.58 – 74

Piano's shifting microtonal hue – bb.74 – 85					
Bars	bb.74 <sup>3</sup> – 77 <sup>3</sup>	bb.77 <sup>3</sup> – 79 <sup>3</sup>	bb.79 <sup>3</sup> – 82 <sup>3</sup>	bb.82 <sup>3</sup> – 84 <sup>3</sup>	bb.84 <sup>3</sup> – 85
Microtonal hue					
'Silent' harmonic field	E1	E-flat1	C2 A1	D1	E1

Figure 3. 43: evolution of piano's microtonal hue, bb.74 – 85

This shifting microtonal hue playing out through the natural resonance of the piano is 'framed' by a kind of hocket line within the ensemble. This line consists of two 'phrases'. The first unfolds between bb.58 – 71. It is primarily articulated by the bass clarinet and viola. As illustrated in the image below, its registral span is very narrow. The bar numbers denote the entry point of each tone.

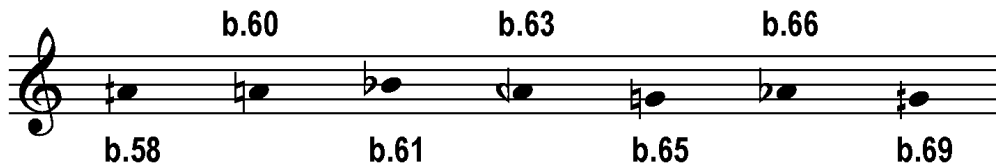

Figure 3. 44: ensemble's hocket line, points of pitch change, bb.58 – 71

The boundary between the first and second 'phrase' is somewhat blurred. The second 'phrase' roughly unfolds between bb.69 – 85. It is articulated by the bass clarinet paired with bass flute, and the viola paired with violin. As illustrated below, its registral span is significantly wider than the first 'phrase'.

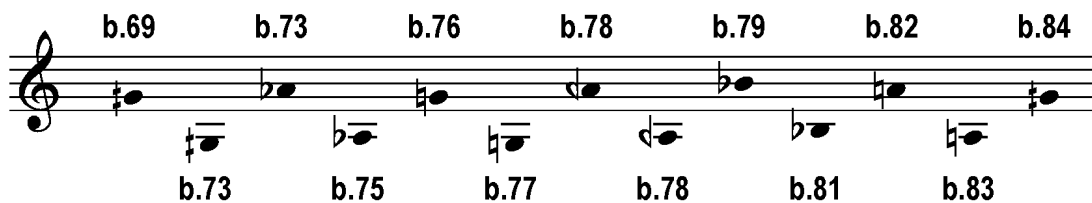

Figure 3. 45: ensemble's hocket line, points of pitch change, bb.69 – 85

This phrase is a kind of mirror-image of the first. The phrases seem to wind their way through the landscape's limited pitch pool via a symmetrical wave-like intervallic pattern. This is illustrated in the images below. The numbers denote quartertones. I wonder how perceptible this will be in experience.

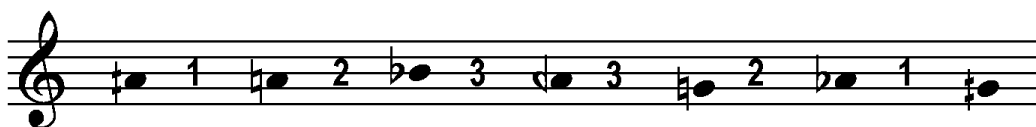

Figure 3. 46: symmetrical intervallic wave



Figure 3. 47: symmetrical intervallic wave

This unfolding line seems somewhat detached from the shifting microtonal hue of the piano's resonance. I wonder if this sense relates to differences in character.

The boundary between the second and third landscape is blurred. The third landscape roughly corresponds to bb.87 – 99.

Musical score for measures 86-88, featuring six staves: Bfl, Bcl, Pno, Vln, Vla, and Vc. The score includes various dynamics and performance instructions.

**Measure 86:**

- Bfl:** *ppp* (5 notes)
- Bcl:** *ppp* (5 notes)
- Pno:** *ppp* (chords)
- Vln:** *ppp* (5 notes)
- Vla:** *ppp* (5 notes)
- Vc:** *ppp* (5 notes)

**Measure 87:**

- Bfl:** *ppp* (5 notes)
- Bcl:** *ppp* (5 notes)
- Pno:** *ppp* (chords)
- Vln:** *ppp* (5 notes)
- Vla:** *pp* (5 notes)
- Vc:** *pp* (5 notes)

**Measure 88:**

- Bfl:** *p* (5 notes), *ppp* (5 notes)
- Bcl:** *ppp* (5 notes)
- Pno:** *ppp* (chords)
- Vln:** *pppp* (5 notes), *ppp* (5 notes)
- Vla:** *pppp* (3 notes), *pp* (5 notes)
- Vc:** *ppp* (5 notes), *pp* (5 notes)

Performance instructions include:
 

- Bfl:** *ppp*, *ppp*, *p*, *ppp*
- Bcl:** *ppp*
- Pno:** *ppp*
- Vln:** *ppp*, *pppp*, *ppp*
- Vla:** *ppp*, *pp*, *pppp*, *pp*
- Vc:** *ppp*, *pp*, *ppp*, *pp*

Additional markings:
 

- Bfl:** **G** (measure 88)
- Vln:** **G** (measure 88), *I ord.* (measure 88)
- Vla:** *IV 1/2 SP arco flaut.* (measure 86), *I 1/2 SP arco flaut.* (measure 87)

Figure 3. 48: blurred boundary between the second and third landscape, bb.86 – 88

As it emerges and unfolds, it seems to contrast with the previous landscape. The centre of gravity shifts to E-natural. I imagine these abrupt centre of gravity changes being felt in experience as a kind of stark ambiguous global shift, rather than as a clear intervallic relationship (“Oh, that’s a perfect fifth”). Something we have a kind of distant sense of. This landscape is the most fleeting. A very intricate and dynamic surface plays out through a palette of just three tones, centred around E4 and E5.

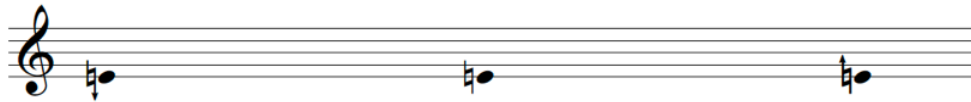

Figure 3. 49: *third landscape, pool of pitches*

This very limited pool of tones, along with a shift to a kind of forty-eight tone equal tempered tuning space, prompts a transformation within the microtonal hue. The evolution of this landscape seems more subtle than the previous two. Curiously, it seems simultaneously animated and still. In contrast to previous landscapes, all tones are in play at the outset. There is a notable absence of a gradual increase in spectral density. This seems to infuse the landscape with a hovering-like quality. Complemented perhaps, by a seeming difference in the way the whole ensemble interact/relate. All instruments seem to speak as one composite voice. This is particularly noticeable in the way the parts interlock. For example, as in b.91.

The fourth landscape corresponds to bb.100 – 128. The landscape change appears very stark.

**H**

100

Bfl

Bcl

Pno

*mp*

*p*

*pp*

Ped.

Sost.

**H** 1/2 SP  
flaut.  
(slightly faster than Vc)

Vln

*ppp*

ord.  
flaut.  
(slightly slower than Vln)

Vla

*ppp*

Vc

1/2 SP  
(match speed of Vc)

1/2 SP  
(match speed of vln)

Figure 3. 50: shift to fourth landscape, bb.100 – 102

I think a key carrier of this sense of jarring contrast is the interval of seven semitones playing out within the surface aspects of the music. Four centres of gravity are in play.

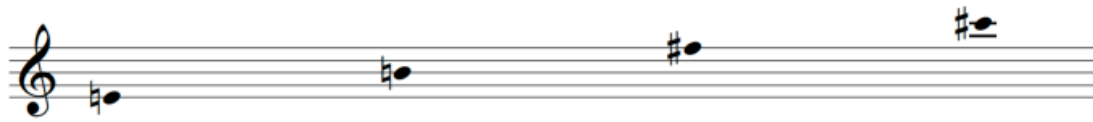

Figure 3. 51: landscape four, pool of pitches, bb.100 – 118

Expressed as chords, dyads, or single tones by the piano, these are infused with a certain clarity by the crystalline qualities of the piano’s middle register. This sense of clarity is somewhat obscured or blurred by a microtonal hue unfolding within the strings. In bb.100 – 103, they sort of smudge a single tone of the piano’s constellation. For example, in bb.100 – 101 the violin and viola oscillate between B4 and the eighth-tone below and above, respectively (see figure 3.50). Similarly, in bb. 102 – 103, the violin and violoncello oscillate between E4 and the quartertone above and below, respectively. From b.104 onwards, the strings microtonally stretch and compress a specific aspect of the piano’s intervallic constellation. Namely, the interval of seven semitones. This stretching and compressing unfolds in various wave-like shapes. (e.g. compressed-stretched-stretched-compressed). This seems to form something akin to a halo around the piano. Illustrations of these ‘waves’ can be seen in the table below. The table shows how this shifting microtonal hue in the strings unfolds from b.104 to b.118<sup>3</sup>. One iteration of each variation is shown.

Strings’ shifting microtonal hue bb.104 – 118 <sup>3</sup>	
Key: S – most compressed   s – slightly compressed   7 – seven semitones   l – slightly stretched   L – most stretched	
Bar(s)	How interval of seven semitones is stretched and compressed
b.104	<p style="text-align: center;"><b>[S-s-l-L-l-s-S]</b></p>

bb.105  
- 106

[S-s-l-L]

vln

vla

bb.107  
- 109

[s-7-l-l-7-s]

vln

vla

bb.110  
- 112

[s-7-l-l-l-s]

vla

vc

bb.113 – 116	<p style="text-align: center;"><b>[S-7-L-L-7-S]</b></p>
bb.117 – 118	<p style="text-align: center;"><b>[s-7-l-l-7-s]</b></p>

Figure 3. 52: strings shifting microtonal hue, bb.100 – 118

Except for the first and last variants, these all stretch and compress the relationship between B4 and F-sharp5. The wave-like shapes are all different. Some more subtly so than others. These differences are complemented by shifts in rhythmic presentation, phrasing, the way these aspects interact with the dynamic morphology, instrumentation, and timbre. I wonder how we might experience these waves and the shifts between them in listening. I wonder if we might sense a certain kind of motion or shift, but not its details in the moment. The bass flute and bass clarinet drop in and out of the texture, expanding the relatively limited pool of pitches in play with tremolando anchored on G-natural and A-natural, and C-natural and D-natural, respectively.

A shift in the landscape occurs in b.118. The centres of gravity change to –

Their presentation in various configurations alters and expands the intervallic constellation in play. For example –



This shift in the piano's constellation is accompanied by a shift in the way the string's microtonal hue is expressed/plays out. Prior to this point, the landscape dwells on each permutation of the wave-like thing for an extended duration. From b.118 onwards, numerous permutations are presented in fleeting succession with varying degrees of overlap. Each iteration is different and only appears once. They microtonally stretch and compress the interval of seven semitones. This stretching and compressing plays out in patterns not unlike previous variations. However, the patterns are more varied and slightly less symmetrical. Rhythmic presentation and playing technique blur some of this patterning somewhat. Examples of this can be seen in the table below. The table shows snapshots of the ensemble's shifting microtonal hue between bb.118<sup>3</sup> – 128.

Examples of the ensemble's shifting microtonal hue bb.118<sup>3</sup> – 128

Key: S – most compressed | s – slightly compressed | 5 – five semitones | 7 – seven semitones | l – slightly stretched | L – most stretched

Bar(s)

How interval of seven semitones is stretched and compressed

b.118<sup>3</sup> – 120

[s-l-7-l-s-s-l-s-7-s-l-7-7-l-7-l-s]

bb.119<sup>1</sup>

[s-7-l-L-l-7-s]

bb.120<sup>4</sup> – 121

[S-s-l-L-l-s-S]

vla

vc

S 7 L S 5 L

bb.121<sup>3</sup>

[S-s-l-L-7-S]

Bfl

Bcl

S s l L 7 S

bb.121<sup>4</sup> – 122

[s-7-l-l-7-s]

vln

vla

bb.123<sup>2</sup>

[S-s-l-L-l-s-S]

Bcl

vc

bb.125 – 126

[s-7/l-l/l-l-7/l-s]

Bcl

vla

bb.126<sup>3</sup> – 127

[l-s-s-l]

Bfl

vln

b.128<sup>1</sup>

The image shows a musical score for violin (vln) and viola (vla). The violin part is in treble clef and the viola part is in bass clef. Both parts are in 7/8 time. The violin part features a triplet of notes marked with a bracket and the number '3'. Above this triplet is the notation [s-7-l-7-l-7-s]. Below the violin staff, there are six boxes containing the letters 's', '7', '|', '7', '|', '7', 's'. The viola part features a triplet of notes marked with a bracket and the number '3'.

Figure 3. 53: strings' shifting microtonal hue, bb.118 - 128

A seemingly subtle shift in the landscape occurs in b.126<sup>3</sup>. The introduction of a new pitch, F4, by the violin (see the second to last snapshot in figure 3.53). I wonder how we might experience this. I wonder if it might feel more striking in experience than its seeming subtlety suggests.

The fifth landscape corresponds to bb.129 – 149. Its boundary seems very stark. A single expression of an interval of seven equal tempered semitones is laid bare within the surface of the music. It is no longer blurred or obscured by any kind of microtonal hue. For the first time, the microtonal hue is stripped away. Abruptly and in its entirety. I wonder if it is at this point that we might, as listeners, become more aware of a sense of stark transparency.

The musical score is divided into three measures. Measure 129 is marked with a box containing the letter 'K'. The Bfl and Bcl parts have rests. The Pno part features a 5:4 interval with dynamics *ppp* and *p*. The Vln and Vla parts have rests. The Vc part has a whole note. Measure 130 is also marked with a box containing 'K'. The Bfl and Bcl parts have rests. The Pno part features a 5:4 interval with dynamics *pp* and *p*. The Vln and Vla parts have rests. The Vc part has a whole note. Measure 131 is marked with a box containing 'K'. The Bfl and Bcl parts have rests. The Pno part features a 5:4 interval with dynamics *pp* and *p*. The Vln and Vla parts have rests. The Vc part has a whole note. The score includes various musical notations such as dynamics (*ppp*, *p*, *pp*), articulation (accents), and performance instructions like 'Ped.' and 'Sost.'. The Vln and Vla parts have a 5:4 interval with dynamics *ppp* and *pp*. The Vc part has a whole note.

Figure 3. 54: shift to fifth landscape, bb.129 – 131

I think this landscape will feel both familiar and unfamiliar. The emergence of seventh harmonics on the violin's G string and the viola's C string in b.130, which seem to breathe in and out, suggests this interval of seven semitones is, perhaps, not quite as it seemed. This might call into question assumptions we may, or may not have, about form. I sense a kind of gentle insistency within the music itself, like it is asking, prompting, its listener to question their sense of emerging form. Tremolandi between the seventh and eighth partials, sixth and seventh partials, and seventh and ninth partials of the violoncello's C string and G string fade in and out of the texture. These unfold in wave-like shapes reminiscent of landscape four. There are three permutations. These are shown in the images below. In all three the wave takes the form of an increasing-decreasing interval size.

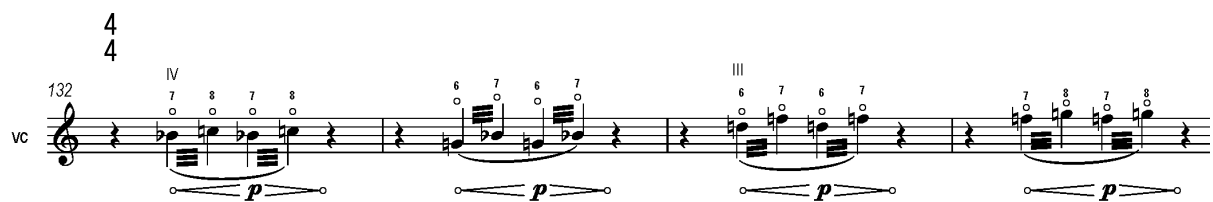

Figure 3.55: Vc tremolandi, bb.132 – 135



Figure 3.56: Vc tremolandi, bb.136 – 139



Figure 3.57: Vc tremolandi, bb.141 – 146

These catapult the unfolding landscape into a very different kind of tuning space. An unexpected space, perhaps. A different kind of hue. I think this sense of being somewhere unexpected, yet perhaps familiar in some way, will be heightened by the way certain aspects in play expand the perceptual horizon. For example, in contrast to all previous landscapes, the bandwidth of the registral space here seems vast and cavernous. Listeners are

introduced to the deep sonorous qualities of the bass clarinet's and bass flute's lowest registers, and the height of the strings' natural harmonics, for the first time as they collectively breathe in and out of the landscape. As the landscape unfolds, a certain kind of hue seems to emerge. In b. 131 the piano's <B-flat4 – F5> dyad is fleetingly infused with a seventh partial-like hue by the silent depression of C2 and G2. The dyad shifts in b.132 to <C5 – G5> infusing the piano's resonance with a more eighth partial-like hue. In a similar way, this dyad acquires a seventh partial-like hue in b.142 with the silent depression of D2 and A2. This hue seems more complex as C2 and G2 are sustained by the sostenuto pedal until b.146<sup>3</sup>. These shifts in the piano are complemented by shifts in the violin and viola's harmonics in b.140 and b.143, and a single shift in the bass flute and bass clarinet's bare interval of seven semitones in b.143. Collectively, these aspects seem to create an increasingly complex hue. There is something intriguing about this hue and the way it emerges. It seems to be infused with a certain transparency absent from the shifting microtonal hue of previous landscapes. It seems to lend to the unfolding music an impression of something like indefiniteness. As though the music is retreating. Continuing to unfold beyond the limit of our hearing.

Interestingly, in the introduction to this commentary I cited Feldman's *Coptic Light* and *For Samuel Beckett* as examples of situations where I experience a sense of disorientation immediately. Almost like the thing started unfolding before it was audible. This sense of being 'dropped-in' seems to come about through a very dense and active texture playing out within the surface aspects, which exceeds my capacity to attend. It is difficult to latch onto anything, to prioritise anything. No aspect is lent a certain primacy in my attention. In contrast, the presentation of things in *finding a thread* seems to do just that. It focuses right in on a single thing or a few things, almost like a magnifying glass is being held gradually closer and closer to it. Something *is* given primacy in our attention. Like *Coptic Light* and *For Samuel Beckett*, the surface presentation in *finding a thread* is dense, intricate, active, and dynamic. But perhaps the way this dense and active surface plays out in experience, the function or role it acquires, might be different. I am wondering here about its capacity to conceal or obscure a sense of stark transparency, its antithesis, if you like. To make this a kind of paradoxical sense that we acquire, perhaps in retrospect.

### 3.4.5 Form (as experienced)

Listening to *finding a thread*, three things seem particularly striking. Its formal ambiguity. The way it seems to acquire a sense of resonance and depth. Its stark, even austere, transparency and sense of emptiness.

This transparency has a unique quality. It seems to be a sense that I acquire. Something that I became aware of in retrospect. It takes time for the things behind to be distinctly seen. From within the interplay of unfolding moments and shifting landscapes, my attention is absorbed by the very active and dynamic surface. It feels as though there is a different kind of acquired paradoxical sense at play. Something like transparency hidden within opaqueness. The opening thing feels like it contains so much. Conceals so much. It has a kind of weighted-ness. It seems to gradually reveal aspects of itself, qualities that I did not initially notice, as it prompts my viewpoint to constantly shift. As the opening landscape unfolds, my sense of disorientation and confusion accumulates. The second landscape has a similar quality, a sense of being more than what it appears. Contained in some way. Allowing in to view only select aspects of itself. This sense seems to accumulate as the music unfolds through the second, third and fourth landscapes. The discreteness of the landscapes, and fleetingness of the third, really disorientate me. It is like my memory runs out of opportunity to 'catch up' before the landscape abruptly changes, again. The high density or degree of detail playing out on the surface is stark. Yet it feels like it is concealing so much more behind it. As the landscape retreats, I find a sense of paradox when I realise, in retrospect, that this detail was concealing something transparent.

The expansive spaces or landscapes seem to 'just be'. There is no sense that they are going anywhere in particular. A sense of drama, or heightened drama, emerges within the shifts between the seemingly discrete landscapes. These in-between spaces engender a sense of stark contrast, of discontinuity or break in continuity. "Ah!" moments. Gaps. These seem to layer a sense of disorientation on disorientation. Yet, paradoxically perhaps, they also seem to be the way through. Gaps cause me to lose the thread in the moment yet are also an intrinsic aspect of what I come to sense the thread to be. They question my assumptions and expectations. They call my memory and listening to attention. My memory feels fragile. The expansiveness of the spaces, their discreteness, challenges my memory. Reveals its vulnerabilities.

The first landscape reaches a point where it feels like it should change. I expect it to change. But it does not (my sense of disorientation accumulates rapidly). Yet, curiously, it feels like the context has changed. Perhaps, it is my expectation that engenders this sense of recontextualisation. The absence of change contradicts my expectation. I am disorientated. It is almost like discontinuity is emerging out of continuity. This kind of dynamic interplay between expectation and contradiction prompts me to feel and find my own way around the space. I

wonder if some of my expectations emerge from my feeling my own way around the space that the music opens up. The music itself seems less direct in suggesting certain kinds of expectation.

From within the interplay of the unfolding landscapes and in-between spaces, my impression of the form feels ambiguous. It remains this way in retrospect. And yet, there is something about this ambiguity. Something I cannot pin down. It is a kind of ambiguity that seems to *lend* something to my sense of form. To infuse it with a certain kind of richness. A sense of resonance and depth. It is palpable. And yet, I cannot grasp it, or give words to it. My sense of form is both strikingly tangible and elusive. I sense it, profoundly. But what this thing is that I sense in retrospect, I am not sure. Perhaps this very wordless tangibility, its absence of thingness, is the resonance and depth.

A sensation of directedness seems to arise as I feel my own way around the space. The form is not telling me where it is going. A space is being opened up. I'm being invited to dwell within it. To find my own path through it. The pathways through it feel numerous. The way I find seems to depend upon my memory. The fragile traces left behind. My capacity in the moment to delve around in my memory whilst keeping track of the music's continued unfolding. That ever-dynamic, and perhaps demanding, interplay between actual moments and echoic traces. There is a sense of fragmentation in-between the discrete landscapes and within aspects of the moment-to-moment unfolding. It is disorientating. Disconcerting, even. Yet, in retrospect, I find a sense of something resembling continuity. Coherency. Those things that seemed at odds with one another seem to have acquired a sense of relationship, cohesion, of belonging. I grasp it and yet I cannot grasp it.

It feels like this sense of a thread or threads found resides within the blurred space in-between the music and me, the listener. The sense of coherency that I acquire seems to be active, unstable, and relative. To borrow from Reed Doob's ideas about labyrinths, as a listener I am like a maze-treader. My experience is about finding the path to something. This path feels inherently disorientating and dynamic. It is a kind of interplay between dwelling and memory. A memory that is vulnerable to errors, distortions, modifications, and has a tendency to go awry. I sense the path to, and the retrospective thread(s), are unique to me, in that moment. It is as Ingold said, '...the last line drawn is never the last line that could have been drawn...' <sup>14</sup>

---

<sup>14</sup> Ingold (2010): 100.

### 3.4.6 Reflections and Insights

There is a single thread that underlies and connects all of the works in this portfolio. It goes something like this: we somehow have a certain sensitivity to the paradox of a situation of a thing concealed within its antithesis, such as coherency concealed within incoherency, continuity concealed within discontinuity, or transparency hidden within opaqueness, as something that lends a sense of resonance and depth in experience. I think *finding a thread* embodies this idea. Within the act of making, I had a heightened awareness or sense of it. I say heightened because I think I sensed something of its presence in previous works, particularly *for serge*. But with *finding a thread*, it felt different somehow. More palpable, perhaps.

I sensed something similar within the act of listening. Its presence seems almost tangible, yet elusive too. Its lack of 'thingness' makes it very difficult to grasp and describe or speak about in any kind of concrete way. I think it resides and evolves somewhere within the space in between what I as the artist, or we as listeners, grasp or sense in ephemeral moments when things happen and what I/we sense (perhaps about these things) in retrospect. The temporal nature of music means we are always, to some extent at least, looking back, inhabiting the moment, and looking forwards, all seemingly simultaneously. It is as though we are dwelling within '...the past [that] lives constantly alongside the present.'<sup>15</sup> Finding something within this dwelling place. It is a kind of interplay or space-in-between our immediate attention and traces in memory, and the assumptions we might make from this about form. There is a suggestion here that this sense of resonance and depth is dynamic, electric even, active/participative, relative, and fragile. It seems to be about finding my own path through the space being gradually opened by the unfolding music and the echoic traces being left behind in my memory. Within the act of making and listening, it is as though my viewpoint, so to speak, changes as context accumulates. I think this viewpoint and any sense of acquired resonance and depth are inherently linked and interpenetrative. Not unlike Reed Doob's observations of maze perception, my sense of acquired resonance and depth, of emergent form, feels intrinsically unstable and completely relative. It depends upon my viewpoint. I sense this viewpoint is not a fixed, single, or a universal thing. It is infused with context. With recontextualisation.

Context is a part of the thing, the space in which that thing unfolds, and the filter through which I experience or frame it. Context encompasses everything. The properties of the music itself, somehow independent

---

<sup>15</sup> Salley (2015): 3.

of the listener. Whether or not my attention/concentration wanders, and when and where to. The things I find within the act of rummaging around in my memory. My expectations. The aspects of the music I latch onto or that call or absorb my attention. The things I question and when. My viewpoint. My processing capacity. My sense of stamina, patience, concentration, and endurance in the moment. My sense of things changes in relation to context. Changes of context shift my viewpoint. Recontextualisation can enable us, as listeners, to grasp something of the evolving thing that we could not grasp previously or that we perhaps mistook. It can heighten, expose, or conceal qualities, changing what is in play within the surface of the music. This could bring to the attention of our immediate radar something different, which through memory might change our viewpoint, our sense of the emerging whole. Recontextualisation leaves gaps. Changes to what is playing out on the surface of the music may suggest things that openly contradict or subtly call into question what we previously thought to be so. Our assumptions, expectations, and memories are ‘...continuously renegotiable in response to changes in context...’<sup>16</sup> Recontextualisation points to the thing being formed, but what I ‘see’ depends upon my viewpoint. This viewpoint seems to be a kind of dynamic interplay between expectation, contradiction, and memory.

Our viewpoint can shift numerous times through the duration of a thing’s unfolding. There might be a feeling or sense of tension between some, or all, of these viewpoints. A sense of contradiction, paradox even. I think it is within these potential tensions, or gaps perhaps, which are entirely depended upon memory, that a sense of resonance and depth brews and emerges. Our sense of form, or enduring impression of the global thing, is perhaps an imprint of the accumulation of these tensions or gaps between viewpoints and how we felt our own way through. The path we found through the shifting shapes of the accumulating context. The thread we found.

There is something about this in-between place where aspects of context intermingle, interact, and merge; a kind of shifting interpenetration. Its potent potential to infuse form with paradoxical qualities (in retrospect). The way it frames the listener as a constitutive aspect of emergent form, of what they sense the form to be. The way it asks or encourages a listener to feel their own way. The way it speaks about form as something that is a dynamic process, based on relations, found within, active, flexible, and about the path to something. This path and the thing we find, the sense of tension between this in-between space and what we know in retrospect, the paradoxical sense we acquire, will be unique to each of us. Form is not told. It is occupied and discovered.

---

<sup>16</sup> Hanninen (2012): 331.

### 3.4.7 Conclusion

*finding a thread* frames continuity as something that is ‘...born of [our] relation with things’.<sup>17</sup> As something that depends upon the ‘...totality of what is there’.<sup>18</sup> As my Neurodiversity support tutor said when discussing form in my music, “...how can we take and explain the impact of the sky without the clouds that sprawl across it, the time of day that shades it, the skyline that punctuates it...all of it makes the sky...”<sup>19</sup> This captures my experience of making and listening. As the artist, I felt like a wanderer, ‘...weaving of, and through, active materials....’<sup>20</sup> There was a depth to my experience of making, of finding a thread within the act of making, that recalls something of Bryn Harrison’s description of listening, as something that ‘...requires one to be alive to our auditory response...to engage all our faculties in an aural act which, in an instance, has the potential to transport one...to a condition of heightened awareness.’<sup>21</sup> My experience was infused with a dynamic quality unlike that of making *for serge* or *inside-out*. It felt like I was dwelling within things *and* melding with those things *and* following the pathways they opened.<sup>22</sup> It was as though I found what John Cage spoke about in relation to listening and his solo piano work 4’33” (1952), a certain kind of attentiveness, openness, and receptivity.<sup>23</sup>

### 3.5 Conclusion

The acts of making *yx* and *for PlusMinus* were about giving effect to a preconceived idea about or abstract sense/concept of form. In contrast, the acts of making *for serge*, *inside-out* and *finding a thread* were about form-finding. I think this is the difference between thinking *then* making and thinking *through* making.<sup>24</sup> Form *before* materials to form *from* materials. The latter is about gradually discovering form, some kind of concrete sense of it, as I, as artist or listener, dwell within things. To borrow the words of Tim Ingold, the acts of making *for serge*, *inside-out*, and *finding a thread* were experiences of ‘...bringing together diverse materials and combining or redirecting their flow in the anticipation of what might emerge...’<sup>25</sup> Joining with and following the ‘...forces and flows of the

---

<sup>17</sup> Merleau-Ponty (1965): 434.

<sup>18</sup> Kramer (1988): 218.

<sup>19</sup> Emma Allsopp, 10<sup>th</sup> November 2021.

<sup>20</sup> Ingold (2010): 93.

<sup>21</sup> Harrison (2011): 269.

<sup>22</sup> Ingold (2010): 97.

<sup>23</sup> (Kostelanetz (2003): 250) and (Gann (2010): 191).

<sup>24</sup> Ingold (2013): 6.

<sup>25</sup> Ingold (2010): 94.

material...' that brings form '...into being...' <sup>26</sup> This kind of very gradual emergence of form as I dwell within, respond to, and feel my way through things reminds me of, and seems to resonate with, Kramer's comment about musical time as '...the very personal time created within us as we listen deeply to music.'<sup>27</sup> This process of form-finding took on different attributes and led towards very different musical situations and concerns in each of the three pieces. However, in all three works this process was highly intuitive and participative.

Within this return to intuition, to an intuitive way of encountering and interacting/engaging with form, it feels like the gap between my experience of art/composition within the act of making and within the act of listening has closed. In closing, it feels like it has opened up an entirely new way of encountering my creative practice. It is like I have journeyed along a path from insider to outsider and outsider to insider. But the space I find myself in now feels very different. Different yet familiar. My intuitions have changed.

This project tells a story of a question about continuity. Can continuity be a sense that we, as listeners, acquire over the duration of the music's unfolding? Or framed slightly differently, can I, as an artist, and we, as listeners, experience continuity retrospectively as a kind of acquired sense of resonance and depth? The story began with an abstract way of working. An abstract sense of continuity. The story 'ends' with a creative relationship with continuity based on intuition and discovery. This 'ending' is indebted to the beginning. The abstract way of working set up the journey to this intuitive way of working. To this new kind of relationship with form.

---

<sup>26</sup> Ingold (2010): 97.

<sup>27</sup> Kramer (1988): 6.

## 4. Conclusion

### 4.1 Introduction

This project began with a dialogue about form. This led to a premise. A premise about how continuity might come about in my music. A certain kind of continuity. This has led to many discoveries. To reorientations in thinking. Most pivotal, perhaps, is not a discovery exactly. But more of a narrative. A certain kind of narrative threading through *for serge*, *inside-out*, and *finding a thread*. Tentative at first. A kind of undercurrent. Embodied in *finding a thread*. It is something like an aligning of the way I encounter form within the act of making and experience form within the act of listening. They are both about becoming part of the story of things.<sup>28</sup> Dwelling within, and corresponding with, things. We are, if you like, fellow travellers and dwellers. The listener and I. Fellow explorers. Active participants in a moment of something's becoming. In our experiences of form. Form as a lived experience of things. A sense we acquire and feel in retrospect. A sense that seems to somehow reside, evolve, and emerge within a space in-between. In-between things and me. In-between actual moments and memories. A reflection, of sorts, of the way our sense of things changes and accumulates through time. In making, form is something I gradually find as I dwell within things, following and responding to their suggestions. It is something like intuitively feeling my way through an evolving space in which I am enmeshed. In listening, form is occupied and discovered, not told. The music opens up a space and invites us in to feel and find our own way. Listening and the process of making seem similarly dynamic, temporal, active, participative, and intuitive. These thoughts, discoveries, point to form as something that comes about through things, how those things interact, and how we interact with them. They frame continuity as a sense we might acquire over the duration of a music's unfolding. A sense that might feel paradoxical in some way.

This new way of encountering form as an artist, of relating to the listener, has led to a new way of working and interacting with materials/things. A different relationship with the kinds of materials I work with. The kinds of things I dwell within. These things emerge organically and gradually as I intuitively feel my way. I interact with, or think of, these things as bundles of qualities and behavioural tendencies. There seems to be a certain kind of

---

<sup>28</sup> Ingold (2021): 7.

flexibility and economy embedded within this. It focuses my attention on discovering the variety inherent within things. I think this has led to a greater awareness of differences that make a difference in experience when working with things with a certain indefinite quality. It feels like aspects of experience have become a more constitutive part of my creative decision making.

## 4.2 Form-finding

As an artist, I began this project thinking about, and encountering, form as something that comes *before* materials. Composing as a process of thinking *then* making. The act of making as a kind of intuitive response to an abstract sense of form. This abstract sense of how a group of things, not yet known, might relate, and how their relationship might become more entangled and acquire complexity through time, was my guide for *finding* the materials. These materials were 'moulded' to the abstract form. Unknown things encouraged to work with or fit an unrelated abstract sense of something. To give effect to a preconceived impression. This kind of relationship with form felt fixed, rigid, inflexible, non-participative, and unintuitive. The composition portfolio tells a story of my journey towards a very different kind of creative relationship with form. A very different way of encountering form within the act of making. Within the making space in-between *yx* and *finding a thread* I learnt something like this, '...even if the maker has a form in mind, it is not this form that creates the work. It is the engagement with materials [things]...'.<sup>29</sup>

Making is about dwelling within things. Within the inner life of things. To dwell is to correspond with things in real-time. To mix, merge, and meld with those things in '...anticipation of what might emerge'.<sup>30</sup> To become enmeshed in and entangled with things. To dwell is to follow. As I dwell, I uncover things. I follow these things. Following is about listening. Going with it. Tracing the movement of something. Following reveals new things. I respond to these things. To follow is to respond to the suggestions and wanderings of things. In responding, I uncover things. Make discoveries. My viewpoint shifts. I adjust. I follow again. This kind of dialogue between listening and responding, between revealing and uncovering, feels very dynamic. Making is about '...prising an opening and following where it leads'.<sup>31</sup> Again and again. In dwelling within the inner life of things, I go along with

---

<sup>29</sup> Ingold (2013): 22.

<sup>30</sup> Ingold (2013): 21.

<sup>31</sup> Ingold (2013): 7.

and continually answer to ‘...the fluxes and flows of the materials...’.<sup>32</sup> There is, I think, a kind of give-and-take between listening and responding. To borrow from Ingold, it is as though the ‘...materials think in [me], as [I] think through them’.<sup>33</sup> Almost like we give to and take from one another. In the process, we are both changed. Ingold likens this kind of correspondence to a relay. Between following and responding, the things and I take ‘...it in turns to pick up the baton and carry it forward...’, so to speak.<sup>34</sup>

In listening, following, and responding, I discover the inner life of things. I gradually find a sense of form. This process feels intuitive, active, participative, and temporal. It is about feeling my own way. Finding my own way ‘...through the tangle of relationships in which [I am] enmeshed’.<sup>35</sup> Dwelling plays out as a kind of interplay between the emerging music’s suggestions and my instinctive responses. It is an in-between sort of space, an interactive space, where I merge with, join forces with, bring together, split apart, synthesise, and distil.<sup>36</sup> It is, as Ingold says, like adding my ‘...own impetus to the force and energies in play’.<sup>37</sup> Following reveals numerous possibilities. How I intuitively respond to these seems to illuminate certain pathways and diminish or conceal others. As things are revealed in following and uncovered in responding, the dwelling space is changed. It is constantly shifting. It is like I am gradually developing a *feel* for the things. This ‘...feeling flows in and out in a correspondence with [things]’.<sup>38</sup> There is a kind of feedback loop between the things and me. Together we are the dynamic dwelling space. A relational in-between space that is in a state of ‘...continuous modulation...’.<sup>39</sup> As I feel my own way, I learn from the things I am working with. I appreciate Ingold’s description of this as ‘...the improvisatory creativity of labour that works things out as it goes along...’.<sup>40</sup>

This kind of experience of dwelling within and in-between things feels not unlike active listening. I am a participant in a lived experience of the things I am working with. My sense of dwelling within these things is very palpable. It is a dynamic and disorientating experience. Following engenders a kind of heightened (listening) attention or awareness. To follow and to respond, I sense I need to approach the process, to dwell within things,

---

<sup>32</sup> Ingold (2013): 6.

<sup>33</sup> Ingold (2013): 6.

<sup>34</sup> Ingold (2013): 105.

<sup>35</sup> Ingold (2016): 3.

<sup>36</sup> Ingold (2013): 21.

<sup>37</sup> Ingold (2013): 21.

<sup>38</sup> Ingold (2013): 108.

<sup>39</sup> Ingold (2013): 25.

<sup>40</sup> Ingold (2013): 20.

with openness, attentiveness, and receptivity. It feels very active. To be attentive is to be able to respond to things in the moment. To be open is to be willing and ready to adjust. “Hmmm...?” moments and “Ah!” moments. As I listen, follow, find, and respond, I journey from a position of outsider to insider. As this process unfolds, things very gradually acquire their formal significance. Things become more entangled and acquire complexity through time. It feels like I am dwelling within something in the very moment of its becoming. Merging with, becoming a very part of the emerging thing. As a dweller. Wanderer. As I dwell, and instinctively feel my way, I gradually find a thread. A sense of form. This sense of resonance and depth is something I acquire in retrospect. I cannot sense it nor grasp it within the dynamic moment of dwelling within things. It is something that I recognise or become aware of from a more distant viewpoint. A sense that feels palpable once the total context has accumulated. Form is, as Ingold observes, ‘...ever emergent...’<sup>41</sup> Ever dynamic. It is something like my basic premise playing out within the act of making.

As this project concludes, I find myself, as an artist, in a very different kind of creative space. A space where making is an act of gradually finding a sense of form through dwelling within things. An experience of finding form within the dwelling space. Form has become something that comes about through things, how those things interact, and how I interact with them in the moment of correspondence. Form-finding as a lived experience of things. My sense of form is, as Ingold says, generated in the ‘...force field, comprised by the relations between the weaver and the willow’.<sup>42</sup> Form emerges from within ‘...the very unfolding of this force field’.<sup>43</sup> The things and I are, perhaps, in a dynamic state of becoming. Intertwined. Interpenetrating. This new relationship with making and form feels like a beginning.

### 4.3 Emergent form

As an artist, I began this project encountering form as something that is *told* within the act of listening. Preconceived. Fixed. Based on live-on-the-surface relationships. I thought of the listener as more of a recipient of form than an active participant in their experience of it. Over the duration of this project, my relationship with the listener has changed. I have found a very different kind of conception of, or way of understanding, form within the

---

<sup>41</sup> Ingold (2013): 25.

<sup>42</sup> Ingold (2013): 22 – 23.

<sup>43</sup> Ingold (2013): 44.

act of listening. Listening is about occupying and discovering form. Form as a sense we acquire. A sense that depends on, and corresponds with, memory. Moments corresponding with echoic traces. Form as something that unfolds through recontextualisation. Slowly falls into place in correspondence, as the listener dwells within, responds to, and feels their own way. A kind of shifting viewpoint. Ever active. Ever dynamic. A sense or impression of the global thing unique to each listener in the moment. I think listening, like making, is about following, responding, and adjusting, in anticipation of what might emerge. In experience, this kind of form feels relational, participative, and personal. Flexible. Retrospective. An impression, a sense of continuity, that feels paradoxical in some way, perhaps.

Reflecting on how this kind of form might come about within the act of listening, four things come to mind. Four key players. Time, listening, memory, and context. These seem interpenetrative. Entangled to an extent that it feels impossible to disentangle them. As I ponder how to go about this, a word and a premise come to mind. Almost like two bookends. The word: gaps. The premise: we somehow have a certain sensitivity to the paradox of a situation of a thing concealed within its antithesis as something that lends a sense of resonance and depth in experience.

Gaps are like feeling time unfold from one moment to the next in a discontinuous way. They tend to engender a sense of fragmentation, disconnection, and disorientation. An absence of continuity. Gaps, or a sense of temporal discontinuity, can prompt a certain kind of active listening. A kind of heightened listening attention or awareness, perhaps. Or possibly, a calling of memory and listening to attention. Something like “Ah!” moments and “Hmmm...” moments. An active listening focused on finding threads of connection. A means to fill in the gaps. Filling in gaps depends upon memory. Gaps seem to engender a sort of dynamic interplay or correspondence between actual moments and traces left in memory. They can prompt a kind of active searching, a rummaging around, in memory for threads of connection, whilst keeping track of the continued moment-to-moment unfolding. Gaps call on memory in a very active way. Call on memory for a sense of form. For a sense of form to be acquired. They can prompt, ask, or invite, listeners to feel and find their own way. To find their own path through, their own story within and through, the space being gradually opened up by the unfolding moments, as they happen, and echoic traces being left behind in memory. To gradually find a thread as they do. This kind of situation seems very dynamic. I think we experience gaps as changes of context. The dynamic interplay between moments and traces as an accumulation

of context. As we, as listeners, try to find traces, retrospective threads of connection, within our memories, these very traces are being continually warped, redrawn, and reframed. As context accumulates, as we actively rummage around within our memories, our viewpoint is constantly shifting. An impression of something changing through time. Gaps feel participative. Emergent. Gaps as a sense of contradiction or tension between the way we feel time unfold within the shifts from one moment to the next and the sense we have through time. Shifts in viewpoint. Moments of adjustment. Gaps as a sense of contradiction between the way we experience relations between things from within the moment to moment unfolding and our impression or sense of these in retrospect. Form as an acquired sense that feels different in some way to our sense or impression within the moment. A kind of acquired paradoxical quality that infuses experience with a certain kind of resonance and depth. Continuity as a sense we acquire. As an active and dynamic process. Relative. Unstable. Something to be found. Continuity as a lived experience of things. A retrospective sense or impression that comes about through things, how those things interact, and how we interact with them through time. Form as the way we experience a work's accumulating context in listening.

#### 4.4 Final thoughts and future directions

The ideas explored here are just that: ideas. They are complex, interpenetrative, vague, difficult to pin down, and dynamic. However, they have exposed and opened up pathways to a very different kind of encounter with, or way of encountering, form. To more open and flexible ways of thinking about continuity and listening in my practice. My viewpoint feels broadened. My horizon widened. These ideas have enabled me to engage with music's capacity to engender a rich variety of formal and temporal experience. To think of form as a sense we acquire. A thread we find. As artist. As listener. A sense of relationship discovered through time and felt in retrospect. A sense that acquires complexity through time as relationships become increasingly entangled. The way we experience time's unfolding as form. A way of encountering form within the act of making that feels interconnected with formal experience in listening. In following the pathways opened up by these ideas, I have come to understand composer-dictation or direction as something more akin to the 'leaving' of gaps. The 'setting up' of situations that might engender tensions of a kind between moments and memories. The leaving of threads, traces of continuity. Something for the listener to find, latch onto, fill-in, or resolve, in experience to acquire a sense of coherency. A

sense of resonance and depth through time. These gaps, tensions, threads suggestive of continuity, emerge organically. Flow from dwelling within things. I have found a new relationship with linearity as a function of memory. I have come to appreciate the interpenetrative relationship between making, form, and listening. Between my perspective on what it means to make, my approach to and understanding of form, and the role of the listener in their experience of form. Following and responding to these ideas, has enabled me to engage with my intuitions. To transform my intuitions. To find a creative relationship with continuity based on intuition and discovery. To engage with the complexity and malleability of form and time through dwelling within things.

As this project comes to a close, and my thoughts turn to future directions, I find myself reflecting on how my compositional thinking and creative practice have changed. In many ways, it feels like it has changed beyond recognition. Yet, the music itself feels strikingly familiar in some way. As I ponder this contradiction, I find myself thinking about surface and sub-surface differences. I wonder if this sense of contradiction is about a very different kind of creative practice playing out through familiar kinds of materials. I continue to gravitate towards things with a certain indefinite quality. To *feel* the things that I work with. Beyond these details, however, I think the way that I interact with these familiar kinds of synaesthetic-like things has changed. A greater sensitivity to the experience of these kinds of things, perhaps. To the way things might be experienced in listening.

In many ways, I feel like I am a very different kind of artist now. The details, the under-surface, of my creative practice seem transformed. The way I think about and engage with form and time feels unrecognisable. Composing as thinking *through* making.<sup>44</sup> Making as dwelling within things. Form *from* things. Formal and temporal experience at the centre of making. The way I interact with materials/things feels familiar and unfamiliar. Their indefinite quality. The way they emerge organically within a correspondence of a kind. Intuitive. Participative. The way I think about listening and relate to the listener feels strikingly different. Making and listening feel more closely aligned. Form in making in a kind of correspondence with form in listening. I think listening has become a constitutive aspect of making. Making as a process of setting up situations that deal with form and time in a complex way in listening.

---

<sup>44</sup> Ingold (2013): 6.

## Bibliography

ARMSTRONG, Newton. 'Listening As A Material'. Conference paper presented at the Troisième Biennale d'Analyse Musicale 2015, 26 – 27 March 2015, Conservatoire royal de Mons.

BOROS, James and Richard Toop (Eds.). *Brian Ferneyhough: Collected Writings*. Amsterdam: Harwood Academic Publishers, 1995. ['Duration and Rhythm as Compositional Resources' (1989)]

BREGMAN, Albert S. *Auditory Scene Analysis: The Perceptual Organisation of Sound*. Cambridge, MA: The MIT Press, 1994.

CAGE, John. *Silence: Lectures and Writings*. London: Marion Boyars, 2009.

CATLIN SMITH, Linda. 'Extremes Within Limits' (8<sup>th</sup> June 1996). Linda Catlin Smith – Composer <<http://www.catlinsmith.com/writings/extremes-within-limits/>> (date accessed: 11<sup>th</sup> October 2017).

CATLIN SMITH, Linda. 'Composing A Theory' (25<sup>th</sup> January 2002). Linda Catlin Smith – Composer <<http://www.catlinsmith.com/writings/composing-a-theory/>> (date accessed: 11<sup>th</sup> October 2017).

CATLIN SMITH, Linda. 'On Listening: A Lecture' (23<sup>rd</sup> September 1992). Linda Catlin Smith – Composer <<http://www.catlinsmith.com/writings/on-listening-a-lecture/>> (date accessed: 11<sup>th</sup> October 2017).

FELDMAN, Morton (ed. B. H. Friedman). *Give My Regards To Eighth Street: Collected Writings of Morton Feldman*. Cambridge: Exact Change, 2000.

FERNEYHOUGH, Brian. 'The Tactility Of Time (Darmstadt Lecture 1988)'. *Perspectives of New Music*, 31 (1993), pp. 20 – 30.

FREY, Jürg. 'And On It Went' (2004). Wandelweiser – Jürg Frey. <[http://wandelweiser.de/\\_juerg-frey/texts-e.html#AND](http://wandelweiser.de/_juerg-frey/texts-e.html#AND)> (date last accessed: 13<sup>th</sup> December 2017).

FREY, Jürg. 'Life Is Present' (1996). Wandelweiser – Jürg Frey. <[http://wandelweiser.de/\\_juerg-frey/texts-e.html#LIFE](http://wandelweiser.de/_juerg-frey/texts-e.html#LIFE)> (date last accessed: 13<sup>th</sup> December 2017).

- GANN, Kyle. *No Such Thing As Silence: John Cage's 4'33"*. New Haven: Yale University Press, 2010.
- GLOVER, Richard, Jennie Gottschalk and Bryn Harrison. *Being Time: Case Studies in Musical Temporality*. New York: Bloomsbury Academic, 2019.
- GOTTSCHALK, Jennie. *Experimental Music Since 1970*. London: Bloomsbury, 2016.
- HAMMOND, Claudia. *Time Warped: Unlocking the Mysteries of Time Perception*. Edinburgh: Canongate, 2012.
- HANNINEN, Dora A. *A Theory of Music Analysis: On Segmentation and Associative Organisation*. New York: University of Rochester Press, 2012.
- HANNINEN, Dora A. 'A Theory of Recontextualisation in Music: Analysing Phenomenal Transformations of Repetition'. *Music Theory Spectrum*, 25 (2003), pp. 59 – 97.
- HANNINEN, Dora A. 'Feldman, Analysis, Experience'. *Twentieth Century Music*, 1 (2004), pp. 225 – 251.
- HARRISON, Bryn. 'The Tempo Of Enclosed Spaces: A Short Personal Reflection Of The Ensemble Music Of Aldo Clementi'. *Contemporary Music Review*, 30 (2011), pp. 269 – 274.
- HURON, David. *Sweet Anticipation: Music and the Psychology of Expectation*. Massachusetts: The MIT Press, 2006.
- INGOLD, Tim. *Correspondences*. Cambridge: Polity Press, 2021.
- INGOLD, Tim. *Making*. Oxon: Routledge, 2013.
- INGOLD, Tim. *Lines*. Oxon: Routledge, 2016.
- INGOLD, Tim. 'The Textility Of Making'. *Cambridge Journal of Economics*, 34 (2010), pp. 91 – 102.
- KOSTELANETZ, Richard. *Conversing with Cage*. New York: Routledge, 2003.

KRAMER, Jonathan D. *The Time Of Music: New Meanings, New Temporalities, New Listening Strategies*. New York: Schirmer Books, 1988.

LACHENMANN, Helmut. 'Hearing Is Defenceless – Without Listening: On Possibilities and Difficulties'. *Circuit Musiques Contemporaines*, 13 (2003), pp. 15 – 27.

MERLEAU-PONTY, M. *Phenomenology Of Perception*, trans. Colin Smith. London: Routledge and Kegan Paul, 1965.

PISARO, Michael. 'Time's Underground' (June 1997). Wandelweiser – Michael Pisaro. <[http://www.wandelweiser.de/\\_michael-pisaro/texts.html](http://www.wandelweiser.de/_michael-pisaro/texts.html)> (date last accessed: 15<sup>th</sup> August 2017).

RAHN, John. 'Repetition'. *Contemporary Music Review*, 7 (1993), pp. 49 – 57.

REED DOOB, Penelope. *The Idea Of Labyrinth: From Classical Antiquity Through The Middle Ages*. New York: Cornell University Press, 1980.

SALLEY, Keith. 'On Duration and Developing Variation: The Intersecting Ideologies of Henri Bergson and Arnold Schoenberg'. *Music Theory Online*, 21 (2015), pp. 1 – 19.

SCHEUREGGER, Martin. 'Fragment, Time and Memory: Unity in Kurtág's Kafka Fragments'. *Contemporary Music Review*, 33 (2014), pp. 408 – 427.

TAKEMITSU, Toru. *Confronting Silence: Selected Writings*, trans. Yoshiko Kakudo and Glenn Glaso. Maryland: Scarecrow Press Inc., 1995.