



City Research Online

City, University of London Institutional Repository

Citation: Carney, D. P. J., Brown, J. H. & Henry, L. (2013). Executive function in Williams and Down syndromes. *Research in Developmental Disabilities*, 34(1), pp. 46-55. doi: 10.1016/j.ridd.2012.07.013

This is the unspecified version of the paper.

This version of the publication may differ from the final published version.

Permanent repository link: <https://openaccess.city.ac.uk/id/eprint/3325/>

Link to published version: <https://doi.org/10.1016/j.ridd.2012.07.013>

Copyright: City Research Online aims to make research outputs of City, University of London available to a wider audience. Copyright and Moral Rights remain with the author(s) and/or copyright holders. URLs from City Research Online may be freely distributed and linked to.

Reuse: Copies of full items can be used for personal research or study, educational, or not-for-profit purposes without prior permission or charge. Provided that the authors, title and full bibliographic details are credited, a hyperlink and/or URL is given for the original metadata page and the content is not changed in any way.

City Research Online:

<http://openaccess.city.ac.uk/>

publications@city.ac.uk

Executive function in Williams and Down syndromes

Daniel P. J. Carney^{a1}, Janice H. Brown^a, and Lucy A. Henry^a

^a *Department of Psychology, London South Bank University, 103 Borough Road, London, SE1 0AA, United Kingdom.*

ABSTRACT

Williams (WS) and Down (DS) syndromes are characterised by roughly opposing ability profiles. Relative verbal strengths and visuospatial difficulties have been reported in those with WS, while expressive language difficulties have been observed in individuals with DS. Few investigations into the executive function (EF) skills of these groups have examined the effect of verbal/visuospatial task type on performance. Analogous verbal and visuospatial measures were administered to these populations within four EF domains: executive-loaded working memory (ELWM), inhibition, fluency and set-shifting. Performance in both groups was compared to that of typically-developing (TD) children using regression techniques controlling for potentially influential cognitive/developmental factors. Individuals with WS showed the expected relative visuospatial difficulties, as indicated by poorer performance than TD individuals, on tests of ELWM and fluency. Individuals with DS displayed the expected relative verbal difficulty in the domain of set-shifting. In addition, each population showed pervasive deficits across modality in one domain; ELWM for individuals with DS, and inhibition for individuals with WS. Individuals with WS and DS showed EF difficulties in comparison to a TD group, but, their executive performance was affected by EF task type (verbal/visuospatial) and EF domain in different ways. While the findings indicated that EF in these populations is characterised by a range of specific strengths and weaknesses, it was also suggested that the relative verbal/visuospatial strengths associated with each

¹ Corresponding author. Tel: +44 (0) 20 7815 5815.

Email addresses: carneyd@lsbu.ac.uk (D. P. J. Carney), brownap@lsbu.ac.uk (J. H. Brown), henrylc@lsbu.ac.uk (L. A. Henry).

population do not consistently manifest across EF domains. Lastly, syndrome specificity was indicated by the differences in groups' performance patterns.

Keywords: Williams syndrome, Down syndrome, executive function.

1. INTRODUCTION

1.1. Cognitive profiles associated with Williams and Down syndromes

The genetic conditions Williams syndrome (WS) and Down syndrome (DS) are characterised by roughly opposing ability profiles. Individuals with WS display relative verbal strengths alongside impairments on visuospatial tasks (Bellugi, Korenberg, & Klima, 2001; Pani, Mervis, & Robinson, 1999), particularly those involving a constructive element (Hoffman, Landau, & Pagani, 2003). Saccadic abnormalities (Brown et al., 2003; van der Geest, et al., 2004), and problems with location encoding (Farran & Jarrold, 2005), as well as the perceptual grouping of elements (Farran, 2005), have all been suggested as contributory factors with regard to these spatial difficulties, while vulnerability of the dorsal stream – a brain region thought to mediate the processing of spatial location and movement (Milner & Goodale, 1995) – has been implicated at the neurological level (e.g. Atkinson et al., 2003; Galaburda & Bellugi, 2000). Individuals with DS show linguistic impairments, particularly in expressive language (e.g. Chapman, 2003), with verbal functioning reported to be below overall cognitive level (e.g. Vicari, Caselli, & Tonucci, 2000). These patterns have been reflected in short-term memory performance: individuals with WS show impairments in comparison to matched comparisons on visuospatial, but not verbal, measures (Jarrold, Baddeley, & Hewes, 1999; Robinson, Mervis, & Robinson, 2003); whereas individuals with DS display difficulties recalling verbal, but not visuospatial, material (e.g. Brock & Jarrold, 2005; Visu-Petra, Benga, Ţincaş, & Miclea, 2007).

1.2. Executive function in Williams and Down syndromes

Investigations into the performance of both groups on measures of executive function (EF) – a frontally-mediated cognitive skill set conceptualised by Anderson (1998) as “those skills necessary for purposeful, goal-directed activity” (p. 319) - have indicated difficulties in this area. For example, individuals with WS and DS show poor performance in relation to matched typically-developing (TD) individuals and task norms (Lanfranchi, Jerman, Dal Pont, Alberti, & Vianello, 2010; Porter, Coltheart, & Langdon, 2007; Rhodes, Riby, Park, Fraser, & Campbell, 2010). However, studies have not generally acknowledged verbal/visuospatial task modality as a potential contributing influence. This is surprising when the ability profiles associated with each population are considered. Furthermore, EF performance has been used to make general claims regarding different populations’ cognitive proficiency. It has also been related to a range of outcomes in both populations, such as adaptive functioning in WS (Rhodes et al., 2010) and theory of mind performance in DS (Zelazo, Burack, Benedetto, & Frye, 1996), as well as suggested as a possible indicator of cognitive decline in those with DS (Adams & Oliver, 2010; Rowe, Lavender, & Turk, 2005). Factors such as task modality, which may influence performance in populations with uneven ability profiles, thus assume greater importance when the potential theoretical and prognostic significance of EF is considered.

The few studies to examine the effect of verbal/visuospatial modality on EF performance in either population have provided some evidence to support this view. With regard to WS, Menghini, Addona, Costanzo, and Vicari (2010) found a specific visuospatial set-shifting impairment, and Atkinson et al. (2003) observed a relative difficulty with visuospatial, but

not verbal, inhibition. Correspondingly, Lanfranchi, Cornoldi, and Vianello (2004) suggested that ELWM skills in individuals with DS may be marginally more compromised with regard to verbal stimuli.

Although these findings are compatible with literature on the respective difficulties associated with each condition, differences in samples (Atkinson et al., 2003; Lanfranchi et al., 2004) and comparison methods (Atkinson et al., 2003) employed across experimental tasks mean that they should be interpreted with caution. Furthermore, many of the previously used tasks were not sufficiently 'pure' in terms of their verbal and visuospatial requirements. For instance, the Trail Making Test used by Menghini and colleagues to assess non-verbal set-shifting employed alphabetic and numeric stimuli which could be verbally labelled.

1.3. Overview of current study

The current study involved the administration of verbal and visuospatial EF task pairs which were analogous, in that processing requirements were as broadly similar as possible across modalities. Tasks within four established EF domains – ELWM, inhibition, fluency and set-shifting – were administered to individuals from *both* clinical populations (DS, WS), to assess potential differences in modality-specific EF performance. These EF domains were selected because they have been identified as key frontal/executive skill areas (Lehto, Juujarvi, Kooistra, & Pulkinen, 2003; Miyake et al., 2000). Individual matching of children between the groups was not undertaken, due to the uneven ability profiles associated with WS and DS; matching participants on any overall cognitive measure may not account for finer-grained verbal and visuospatial differences between groups (Farran & Jarrold, 2003).

Instead, regression analyses controlling for the effects of verbal IQ, non-verbal IQ and chronological age, using dummy-coded group variables, were used to compare each clinical group with a group of typically-developing (TD) children.

The tentative hypotheses were based on the literature pertaining to ability profiles in each clinical group: (1) individuals with WS would display relative verbal strengths – i.e. they would not differ from TD children on verbal EF tasks, but they would show weaker performance than TD children on visuospatial EF tasks (2) individuals with DS would show relative visuospatial strengths – i.e. they would not differ from TD children on visuospatial EF tasks, but they would show weaker performance than TD children on verbal EF tasks.

2. METHOD

2.1. Participants

Seventy-five participants took part; 24 children and adolescents with WS (age range: 8 years 1 month – 18 years 11 months), 25 children and adolescents with DS (10 years 4 months – 18 years 11 months), and 26 TD children (5 years 0 months – 8 years 0 months). Participants with WS were recruited through the UK Williams Syndrome Foundation; participants with DS were recruited through the Down Syndrome Association. TD children were recruited through a primary school in Greater London. Although participants were not individually matched, the range of chronological ages was broadly similar in the WS and DS groups, and the range of mental ages in the typical comparison group was broadly similar to the WS and DS groups. All individuals from the clinical groups possessed formal diagnoses given by appropriate health professionals according to standard diagnostic criteria, and were confirmed by parents/caregivers not to possess any other diagnosis e.g. attention-deficit

hyperactivity disorder, autism spectrum disorder. All TD participants were confirmed, by parents/caregivers, not to possess any diagnosis of special educational needs. All participants were confirmed, by parents/caregivers, as having normal or corrected-to-normal vision and hearing, with English as a first language. Table 1 gives the sample characteristics.

Ethical approval was granted by the Research Ethics Committee at London South Bank University. Informed written consent was obtained from organisations and parents prior to the commencement of testing, and also participants themselves, who were told that they could opt out at any time.

2.2. IQ measure

IQ was measured using the Stanford-Binet Abbreviated Battery (ABIQ) test, a truncated version of the Stanford-Binet IQ test battery (Fifth Edition; Roid, 2003) which takes less time to administer but provides separate scores for non-verbal IQ (NVIQ; max: 36) and verbal IQ (VIQ; max: 74). The non-verbal component of the test is administered first. The Stanford-Binet Technical Manual (Roid, 2003) reports strong internal reliability coefficients for the ABIQ (mean for TD 5-8 year-olds: .91), and test-retest reliability scores (mean for TD 2-20 year-olds: .85). The test also provides an indication of overall mental age (MA); details of these scores per group are also given in Table 1. Separable verbal and non-verbal MA scores are, however, not available, so the separate VIQ and NVIQ measures were used in the analyses.

INSERT TABLE 1 ABOUT HERE.

2.3. EF measures

Executive-loaded working memory. ELWM was measured using two tasks requiring concurrent processing and storage. Verbal ELWM was assessed using an adapted version of the Listening Span task (Leather & Henry, 1994). Participants judged the veracity of orally presented sentences, before recalling the final single-syllable word of each. Span length (i.e. the number of sentences presented before recall) increased from 1 to 4, with progress dependent on 4/6 trials correct at each level. Numbers of trials at each span level were increased from three in the original version to six, to provide greater task sensitivity. The internal reliability of the task was assessed by calculating correlation coefficients between span scores based on each trial at each level, and total span score (for other examples of this approach see Engle, Tuholski, Laughlin & Conway, 1999; and Henry & MacLean, 2002). Internal reliability was moderate (mean: $\tau=.51$). Trials correct (max: 24) were scored, as such scores are more reliable and sensitive than memory span (Conway et al., 2005; Ferguson, Bowey, & Tilley, 2002).

The visuospatial ELWM test was a modified version of the Odd-One-Out test (Henry, 2001). Participants identified the 'odd one out' from horizontal arrays of three abstract figures, before recalling the location of this figure using a blank response board. Trials initially involved one array being presented prior to recall, and progressed to four arrays. Six trials were given at each of these levels, with progress dependent on answering 4/6 correctly. This was raised from three trials in the original task in order to give greater sensitivity.

Arrays were presented on 7"x2" laminated cards. Response boards were laminated A4 cards depicting the relevant number of blank arrays. An example array is given in Figure 1.

Moderate internal task reliability, calculated in the same fashion as described above, was found (mean: $\tau=.45$). Trials correct (max: 24) were scored.

INSERT FIGURE 1 ABOUT HERE.

These tasks have been said to load onto the central executive, rather than tap simple recall skills, as they incorporate both processing and storage demands (e.g. Alloway, Gathercole, Willis & Adams, 2004). It has been claimed that it is this concurrent requirement which specifically demands the recruitment of executive resources (e.g. Baddeley & Logie, 1999; Gathercole, Pickering, Ambridge & Wearing, 2004).

Inhibition. This was assessed using a shortened version of the Verbal Inhibition, Motor Inhibition (VIMI) task employed by Henry, Messer and Nash (2012). For the verbal part, the experimenter said either "doll" or "car", with participants copying for 20 trials, before producing the opposite response for 20 trials i.e. say "doll" if the experimenter said "car" and vice versa. This was followed by a second 'copy' block and a second 'inhibit' block, using the same stimuli. The visuospatial task was the same, with the words replaced by two different hand movements; a pointed finger and a clenched fist.

The original VIMI involved two 80-trial blocks in each task; this was halved following piloting with TD 5-year-olds as they found it difficult to maintain focus. Each 20-trial block was timed using a stopwatch. Two scores – total errors made (max: 80) and total time taken – were

recorded for each task. Internal reliability was calculated by comparing the first 40 trials with the second 40 trials, for both the verbal and visuospatial task, and was moderate (errors - verbal: $\tau=.51$; visuospatial: $\tau=.67$; time - verbal: $\tau=.55$; visuospatial: $\tau=.63$).

Fluency. Verbal fluency was measured using the semantic component of the Word Generation measure from the NEPSY-II test battery (Korkman, Kirk & Kemp, 2007). Participants generated as many exemplars as possible from a given category within 60 seconds. Two trials were given, animals and food/drink. Overall number of correct responses and overall number of repeated items were scored. Correct responses were items produced which belonged to the required semantic category and which had not been previously given within the trial. For the animals trial, names of different breeds within the same species (e.g. “terrier, Rottweiler”), different genders of the same animal (e.g. “cow, bull”), names referring to the same animal at differing stages of development (e.g. “dog, puppy”); and easily recognisable mythical creatures (e.g. “Pegasus, unicorn, dragon”) were counted as correct. Similarly, distinct variants of the same core item (e.g. “lemon chicken, cashew chicken”) and variants of the same dish (e.g. “beef stew, chicken stew”) were counted as correct responses on the food/drink trial, as were any distinct brand names given (e.g. “Fosters, lager”). Words which could feasibly be given for either category (e.g. “fish, chicken”) were counted as correct within each condition, provided they had not already been produced within that condition.

Repetitions constituted any generation of a previously-given item. As well as items identical to those given previously, these included pluralisations (e.g. “tiger, tigers”), as well as diminutive terms (e.g. “pig, piggy”) and previously generated items preceded by an insufficiently

differentiative adjective (e.g. “bear, *big bear*”). The NEPSY-II Clinical and Interpretive Manual reports high split-half reliability of $r=.74$, and a test-retest reliability of $r=.77$, for this task.

Visuospatial fluency was assessed using a modified version of the Design Fluency subtest from the Delis-Kaplan Executive Function System test battery (D-KEFS; Delis, Kaplan, & Kramer, 2001). Participants were presented with identical arrays of unconnected dots, and had 60 seconds to generate as many unique ‘designs’ as possible, by joining the dots. Two conditions were given; Filled Dots - filled/black dots must be connected; and Empty Dots Only - participants must connect empty/white dots, while ignoring filled/black dots. For each trial, 35 identical dot arrays, arranged in a 5x7 landscape formation, were presented. As the D-KEFS is recommended for children of 8 upwards, and the MAs of many of the current sample were lower than this, the task was modified. The ‘four lines per design’ rule was lowered to three, in order to lessen cognitive load, and more modelling provided during instruction. Overall correct designs and repeated designs were scored. Internal validity was moderate to high; $\tau=.59$ for correct designs on the two conditions, $\tau=.81$ for Filled Dots and overall correct designs, and $\tau=.83$ for Empty Dots Only and overall correct designs.

Set-shifting. Verbal set-shifting was assessed with a measure based on the Category Switching subtest from the D-KEFS, in which participants give exemplars from two alternating semantic categories for 60 seconds. The original task was modified in two ways. Firstly, although the original D-KEFS task uses different categories from those used in its complementary verbal fluency measure, the categories employed here, animals and food/drink, were re-used to reduce cognitive load. The measure of interest was the *cost* of switching requirements, calculated by comparing set-shifting performance with

performance on the fluency task. It was felt that re-using the same categories would give a purer measure of switch cost, less compromised by the requirement to generate items from new categories. Secondly, due to the relatively low MAs of the sample, a 'guided' element was introduced. This involved the experimenter pointing alternately to two line drawings, a 'dog' and an 'apple' (Snodgrass & Vanderwart, 1980, names matched for name/image agreement and familiarity) to 'guide' participants between categories. Pictures were 16cmx16cm and positioned centrally on laminated landscape-oriented cards. Reliability was moderate, with total correct responses correlating significantly with combined correct responses from each 15-second period of the Word Generation measure (first: $\tau=.54$; second: $\tau=.47$; third: $\tau=.45$; fourth: $\tau=.41$). Two scores were recorded; correct response cost (mean number of correct verbal fluency responses minus number of correct switching responses) and repetition cost (set-shifting repetitions minus mean number of fluency repetitions). Correct switching responses were any valid category exemplars, regardless of whether they were part of a correct "switch" e.g. a response sequence of "milk, potato, tiger, pear" would constitute four correct responses.

The Switching Fluency subtest from D-KEFS Design Fluency was adapted to provide a measure of visuospatial set-shifting. Participants were presented with empty/filled dot arrays, and generated as many 'designs' as possible in 60 seconds. However, this time they had to 'switch' between empty and filled dots on each trial. The task was modified in the same fashion as the Design Fluency task, with the four-line rule once again reduced to three, and a greater level of modelling provided during instruction. Scores taken were correct response cost, and repetition cost, calculated using Design Fluency scores in the same way as the verbal set-shifting measure. Moderate validity was indicated, with number of correct

Switching Fluency designs correlating significantly with number of correct designs on both visuospatial fluency conditions (Filled Dots Only: $r=.42$; Empty Dots Only designs: $r=.39$).

2.4. Administration

Participants began by undertaking the ABIQ. EF tasks were then given in the fixed domain order of inhibition, ELWM, fluency and set-shifting, with modality alternating. The exceptions to this were the fluency and set-shifting measures. These were administered consecutively from the same modality because set-shifting performance in each was contingent on performance during the corresponding (non-switching) fluency measure. All participants were tested in a quiet room, with no extraneous visual/auditory environmental distractions or influences. Testing of the WS and DS groups took place at participants' homes, across one or two sessions, while testing of TD participants took place at school, across three or four sessions due to curricular demands. Participants were permitted to take a break whenever they wished; children with WS or DS who were tested in one session generally opted to take one or two breaks. The entire battery took around 70 minutes to administer.

3. RESULTS

Table 2 gives scores on each of the EF measures. Hierarchical multiple regression analyses were carried out entering age and IQ variables first to control for their influence. Separate regressions were conducted with each of the EF measures in turn as dependent variables. In all models, chronological age (CA) in months and ABIQ verbal and non-verbal IQ (VIQ/NVIQ) raw scores were entered at Step 1. Although separable verbal and non-verbal MAs would have been more desirable for the analysis, these are not calculable from ABIQ component

scores. In order to assess whether they were group differences after age and IQ had been taken into account, dummy-coded group variables for the WS and DS groups were entered at Step 2. The TD children were always the reference group, so note that direct comparisons between the WS and DS groups were not undertaken. Regression models were constructed in this way as it was felt that a comparison of both groups with typical performance, rather than each other, would be more instructive.

INSERT TABLE 2 ABOUT HERE.

Significant group differences were found for at least one measure in all four EF domains, as indicated by significant R^2 change statistics at Step 2 of the regression models. Table 3 summarises the key statistics for Step 2 of each regression model, illustrating the beta values for the control variables (entered at Step 1) as well as for the dummy-coded group variables (entered at Step 2). All models reported underwent key statistical checks (e.g. ViF statistics, Durbin-Watson, Cook's/Mahalanobis distances, plots of standardised residuals) which indicated independence of errors, lack of multicollinearity, and the absence of cases with undue influence and/or outliers (Field, 2005).

In terms of group differences, individuals with WS obtained significantly lower scores than the TD group on four EF tasks. First, they obtained lower scores on visuospatial, but *not* verbal, ELWM² (see beta-values for WS vs. TD group dummy-variable in Table 3). Secondly,

² As the ELWM tasks involved a storage/recall component, verbal/visuospatial ELWM regression analyses were also conducted incorporating controls for modality-specific short-term memory performance in addition to age, VIQ, NVIQ, and dummy-coded group variables. Group differences for both groups across both modalities, in terms of their relationship to the TD group, were the same as those reported above.

they showed weaker performance on visuospatial fluency in terms of number of correct designs generated and on visuospatial inhibition in terms of time taken. Thirdly, the WS group made a higher number of errors than TD individuals on the verbal inhibition task. Lastly, the WS group showed a significantly greater verbal set-shifting cost than the TD group, in terms of the number of repetitions generated. In sum, individuals with WS showed the predicted modality-specific visuospatial difficulties for ELWM and fluency. Inhibition was impaired in *both* modalities, somewhat counter to predictions, and there was a difficulty with verbal switching that was not predicted.

Individuals with DS showed significantly poorer performance than the TD group on three EF tasks. They had lower scores on both the verbal ELWM and visuospatial ELWM measures (see beta-values for DS vs. TD group dummy-variables in Table 3). Individuals with DS also showed a verbal set-shifting repetition cost: i.e. a greater tendency to perseverate, once a set-shifting requirement was introduced, in comparison to the TD group, than would be expected on the basis of verbal fluency performance. In sum, the predicted modality-specific EF difficulties were found for switching in individuals with DS, but no modality-specific difficulties were present in the other executive areas. ELWM was impaired on both verbal and visuospatial tasks, somewhat counter to predictions.

INSERT TABLE 3 ABOUT HERE.

4. DISCUSSION

Individuals with WS and DS displayed a number of EF difficulties compared to TD children. Analyses controlling for verbal IQ, non-verbal IQ, and CA indicated that individuals with WS showed poorer performance than the TD group on at least one EF measure in all four

domains tested (ELWM, fluency, inhibition, set-shifting), while individuals with DS displayed difficulties in two domains (ELWM and set-shifting perseveration errors).

With regard to the experimental hypotheses, the WS group displayed the predicted visuospatial difficulties in three EF domains - ELWM, inhibition and fluency. However, the difficulties with inhibition also extended to the verbal task and this was not predicted. Our inhibition tasks were clearly challenging for young people with WS whether verbal or visuospatial in nature. Also against predictions, the WS group showed verbal but not visuospatial set-shifting difficulties.

The DS group showed the predicted verbal difficulties on ELWM and set-shifting, but the difficulties with ELWM also extended to the visuospatial task, which was counter to predictions. Individuals with DS did not differ from the TD group in the domains of inhibition and fluency, regardless of task modality. These results suggest that while task modality does influence the EF performance of individuals with WS and DS, its effect is variable across EF domains. Furthermore, individuals with WS were more affected by task modality, in comparison with typical performance, than individuals with DS. These patterns suggest that executive profiles in each population may be syndrome-specific.

4.1. Williams syndrome

The relatively weaker visuospatial performance on ELWM and fluency tasks by the WS group was in line with this population's ability profile. While this indicates that the performance of individuals with WS in these areas may be ultimately underpinned by dorsal stream vulnerability, future work should attempt to not only establish whether general population-

specific verbal weaknesses exist in these domains, but also specify, at a finer-grained level, which particular aspect of visuospatial task demand is problematic e.g. a problem with perceiving the spatial relationships between elements on each task, which may in turn give rise to difficulty planning and/or executing an appropriate motor response.

With regard to the other two EF domains tested, relative verbal strengths were not observed. Firstly, individuals with WS displayed problems on *both* the verbal and visuospatial inhibition tasks. As well as investigating the replicability of these findings, future studies should address two issues. The first of these is whether or not poorer performance than the TD group on *both* modalities reflects the same underlying difficulties; the finding of lower verbal accuracy, but longer visuospatial reaction times, suggests that they do not. In addition, the relationship between weakened inhibitory skills and heightened social behaviour, suggested by some authors (e.g. Porter et al., 2007), should be further investigated. If, as is suggested by the present data, individuals with WS display problems with inhibiting a range of responses, then the role which this may play in the manifestation of an increased social drive should be examined.

Secondly, analysis of the set-shifting task revealed greater verbal, but not visuospatial, repetition costs than the TD group. This was surprising, given the verbal strengths associated with WS. One explanation may stem from the suggestion that switching performance may be linked to inhibitory skill (e.g. Davidson, Amso, Anderson, & Diamond, 2006); the switching difficulties observed in individuals with WS may thus be underscored by the verbal inhibitory problems observed in this group. Alternatively, or as a result of these difficulties, this may highlight a higher-order problem with everyday verbal

performance, one which may be compounded by rapidly shifting semantic/conversational contexts. For example, individuals with WS have been associated with perseverative and dysfluent conversation (Tarling, Perkins, & Stojanovic, 2006); future work could address the relationship between these problems and the frequent conversational breakdowns and/or shifts in topic which these authors have suggested may characterise the conversational profiles of some individuals with WS.

4.2. Down syndrome

The lack of DS/TD group differences on the inhibition and fluency tasks indicates that these skills may develop, in individuals with DS, in line with overall cognitive development.

However, the verbal and visuospatial ELWM difficulties suggest delayed and/or abnormal development in this domain, and resultant problems with everyday tasks requiring concurrent storage and processing. These findings are in line with the verbal and visuospatial complex memory problems reported by both Lanfranchi et al. (2004) and Vicari, Carlesimo, and Caltagirone (1995), although it should be acknowledged that both of these studies employed a different statistical approach to the current study. Nevertheless, the difficulties suggested by the current findings may have potential educational implications, as it has been suggested that these skills are related to progress in reading, spelling and mathematics in typical children (e.g. St Clair-Thompson & Gathercole, 2006). However, as ELWM difficulties in individuals with DS have not always been observed in relation to matched TD controls (e.g. Pennington, Moon, Edgin, Stedron, & Nadel, 2003), this area requires further investigation.

The verbal set-shifting difficulties shown – a greater propensity for repetition than the TD

group, in the face of a switching requirement - may indicate that the influence of task modality on the performance of individuals with DS is mediated by task complexity; set-shifting has been suggested to be one of the more cognitively taxing executive domains, recruiting both inhibition and working memory (Davidson et al., 2006). Individuals with DS may only present with specific verbal executive deficits when tasks are more demanding. Further studies employing a wider variety of “higher order” EF tasks than those used here would, however, be necessary before this notion could be satisfactorily addressed.

4.3. Limitations and possible future directions

A possible limitation of the current study was that visuospatial EF performance may have been influenced by verbal mediation, i.e. the use of verbal strategies for self-regulation. Although we cannot directly test whether this occurred, verbal IQ was rarely related to our visuospatial executive measures, with the exception of ELWM trials correct (negative relationship) and inhibition errors (positive relationship). Although the latter finding – higher verbal IQ predicting a higher number of visuospatial inhibition errors - may indicate that the application of verbal strategies may be detrimental to performance on some tasks, the possibility that participants were using such strategies, such as verbal self-reminding (Russell, Jarrold, & Hood, 1999), remains. Future work could investigate the extent to which articulatory suppression strategies (e.g. Wallace, Silvers, Martin, & Kenworthy, 2009) may influence visuospatial EF performance in groups of individuals with DS and WS.

A notable aspect of the findings was that each regression model left variance largely unexplained (the amount of variance explained in EF performance varied between 3% and 47%). Statistical techniques of the type employed here would enable future work to assess

the additional influence of social/environmental variables, alongside factors such as IQ and age, on EF performance in the two populations. Cognitive development has, for instance, been suggested to be affected by socio-economic factors (Noble, McCandliss, & Farah, 2007), level of parental education (Ardila, Rosselli, Matute, & Guajardo, 2005), disciplinary environment (Talwar, Carlson, & Lee, 2009) and the physical characteristics of the home environment (Faber Taylor, Kuo, & Sullivan, 2002). Such variables may also influence the cognitive performance of individuals with genetic syndromes. Similarly, although groups were not equated on gender composition due to recruitment outcomes and the desire that group sizes be as high as possible, future studies in this area may wish to do this, due to evidence suggesting possible links between EF performance and gender in both typical (Anderson, Anderson, & Garth, 2001; Karapetsas & Vlachos, 1997) and atypical (e.g. Newcorn et al., 2001) populations.

Lastly, as the visuospatial EF measures employed all involved the production of a motor response, it can be argued that the present study may have been strengthened by incorporating a measure of basic motor skill, and controlling for this in the subsequent regression analyses. This would be justified by suggestions that individuals with WS may have specific difficulties with the planning and execution of motor activity, possibly due to compromised dorsal and frontoparietal circuitry (e.g. Atkinson et al., 2003), and that motor skills in individuals with DS may follow an abnormal, or delayed, passage of development (see Vicari, 2006, for a review). However, as it would be reasonable to expect that compromised motor skills would feed into performance on visuospatial EF tasks with motor response demands, it remains to be seen whether studies involving these can successfully address basic motor skills as a separable component. Despite this concern, any attempt to

incorporate a measure of basic motor skills begin to elucidate the extent to which impairment in these processes may impact performance on higher-order visuospatial cognitive tasks.

4.4. CONCLUSIONS

Individuals with WS and DS showed a range of executive difficulties that varied according to EF domain and task modality (verbal/visuospatial). Those with WS showed more EF difficulties, in comparison with the typical group, than those with DS overall; they were also more affected by EF task modality, although this did not always manifest itself in the predicted relative verbal strengths. Furthermore, the pervasive single-domain difficulties experienced by each group – inhibition for individuals with WS, ELWM for individuals with DS – suggest task modality may not always be the most important influence on EF. The data indicate a level of syndrome specificity in relation to EF, and emphasise the importance of using as broad a range of cognitive tasks as possible when assessing the skills of populations with uneven ability profiles. However, further work is needed in order to establish the cross-modality nature of EF skill profiles in each group.

Acknowledgements

We would like to acknowledge the Williams Syndrome Foundation (UK); the Down Syndrome Association; and Yardley Primary School for their invaluable help and support during the data collection period. In addition, we would like to extend our warmest gratitude to the families of the participants who took part, as well as the participants themselves.

References

- Adams, D., & Oliver, C. (2010). The relationship between acquired impairments of executive function and behaviour change in adults with Down syndrome. *Journal of Intellectual Disability Research, 54*, 393-405.
- Alloway, T. P., Gathercole, S. E., Willis, C., & Adams, A. M. (2004). A structural analysis of working memory and related cognitive skills in young children. *Journal of Experimental Child Psychology, 87*, 85–106.
- Anderson, P., Anderson, V., & Garth, J. (2001). Assessment and development of organisational ability: The Rey Complex Figure Organisational Strategy Score (RCF-OSS). *The Clinical Neuropsychologist, 15*, 81-94.
- Anderson, V. (1998). Assessing executive functions in children: Biological, psychological and developmental considerations. *Neuropsychological Rehabilitation, 8*, 319-349.
- Ardila, A., Rosselli, M., Matute, E., & Guajardo, S. (2005). The influence of the parents' education level on the development of executive functions. *Developmental Neuropsychology, 28*, 539-560.

- Atkinson, J., Braddick, O., Anker, S., Curran, W., Andrew, R., & Wattam-Bell, J. (2003). Neurobiological models of visuo-spatial cognition in young Williams Syndrome children: Measures of dorsal-stream and frontal function. *Developmental Neuropsychology, 23*, 141–174.
- Baddeley, A. D., & Logie, R. (1999). Working memory: The multiple component model. In A. Miyake & P. Shah (Eds.), *Models of working memory: Mechanisms of active maintenance and executive control* (pp. 28–61). Cambridge, England: Cambridge University Press.
- Bellugi, U., Korenberg, J.R., & Klima, E.S. (2001). Williams syndrome: An exploration of neurocognitive and genetic features. *Clinical Neuroscience Research, 1*, 217-229.
- Brock, J., & Jarrold, C. (2005). Serial order reconstruction in Down syndrome: evidence for a selective deficit in verbal short-term memory. *Journal of Child Psychology and Psychiatry, 46*, 304-316.
- Brown, J., Johnson, M. H., Paterson, S., Gilmore, R., Gsödl, M., Longhi, E., & Karmiloff-Smith, A. (2003). Spatial representation and attention in toddlers with Williams syndrome and Down syndrome. *Neuropsychologia, 41*, 1037–1046.
- Chapman, R.S. (2003). Language and communication in individuals with Down syndrome. In L. Abbeduto (Ed.), *International Review of Research in Mental Retardation: Language and Communication, vol. 27* (pp. 1-34). Academic Press.
- Conway, A.R.A., Kane, M.J., Bunting, M.F., Hambrick, D.Z., Wilhelm, O., & Engle, R.W. (2005). Working memory span tasks: A methodological review and user's guide. *Psychonomic Bulletin and Review, 12*, 769–786.

- Davidson, M.C., Amso, D., Anderson, L.C., & Diamond, A. (2006). Development of cognitive control and executive functions from 4 to 13 years: evidence from manipulations of memory, inhibition, and task switching. *Neuropsychologia, 44*, 2037–2078.
- Delis, D., Kaplan, E., & Kramer, J. (2001). *Delis–Kaplan Executive Function System*. San Antonio, TX: The Psychological Corporation, Harcourt Brace & Company.
- Engle, R.W., Tuholski, S.W., Laughlin, J.E., & Conway, A.R.A. (1999). Working memory, short term memory and general fluid intelligence: A latent variable approach. *Journal of Experimental Psychology: General, 128*, 309–331.
- Faber Taylor, A.F., Kuo, F.E., & Sullivan, W.C. (2002). Views of nature and self-discipline: Evidence from inner city children. *Journal of Environmental Psychology, 22*, 49–63.
- Farran, E. K. (2005). Perceptual grouping ability in Williams syndrome: evidence for deviant patterns of performance. *Neuropsychologia, 43*, 815-822.
- Farran, E.K., & Jarrold, C. (2003). Visuo-spatial cognition in Williams syndrome: Reviewing and accounting for strengths and weaknesses in performance. *Developmental Neuropsychology, 23*, 175-202.
- Farran, E. K., & Jarrold, C. (2005). Evidence for unusual spatial location coding in Williams syndrome: an explanation for the local bias in visuo-spatial construction tasks? *Brain and Cognition, 59*, 159-172.
- Ferguson, A.N., Bowey, J.A., & Tilley, A. (2002). The association between auditory memory span and speech rate in children from kindergarten to sixth grade. *Journal of Experimental Child Psychology, 81*, 141-156.
- Field, A. (2005). *Discovering statistics using SPSS. (2nd edition)*. London: Sage.
- Galaburda, A. M., & Bellugi, U. (2000). Multi-level analysis of cortical neuroanatomy in Williams syndrome. *Journal of Cognitive Neuroscience, 12*, 74–88.

- Gathercole, S. E., Pickering, S. J., Ambridge, B., & Wearing, H. (2004). The structure of working memory from 4 to 15 years of age. *Developmental Psychology, 40*, 177-190.
- Henry, L.A. (2001). How does the severity of a learning disability affect working memory performance? *Memory, 9*, 233-247.
- Henry, L.A., & MacLean, M. (2002). Working memory performance in children with and without intellectual disabilities. *American Journal on Mental Retardation, 107*, 421-432.
- Henry, L.A., Messer, D.J., & Nash, G. (2012). Executive functioning in children with specific language impairment. *Journal of Child Psychology and Psychiatry, 53*, 37-45.
- Hoffman, J.E., Landau, B., & Pagani, B. (2003). Spatial breakdown in spatial construction: Evidence from eye fixations in children with Williams syndrome. *Cognitive Psychology, 46*, 260-301.
- Jarrold, C., Baddeley, A.D., & Hewes, A.K. (1999). Genetically dissociated components of working memory: evidence from Down's and Williams syndrome. *Neuropsychologia, 37*, 637-651.
- Karapetsas, A., & Vlachos, F. (1997). Sex and handedness in development of visuomotor skills. *Perceptual and Motor Skills, 85*, 131-140.
- Korkman, M., Kirk, U., & Kemp, S.L. (1998). *NEPSY – A developmental neuropsychological assessment*. San Antonio, TX: Psychological Corporation.
- Lanfranchi, S., Cornoldi, C., & Vianello, R. (2004). Verbal and visuospatial working memory deficits in children with Down syndrome. *American Journal on Mental Retardation, 109*, 456-466.

- Lanfranchi, S., Jerman, O., Dal Pont, E., Alberti, A., & Vianello, R. (2010). Executive function in adolescents with Down Syndrome. *Journal of Intellectual Disability Research, 54*, 308-319.
- Leather, C., & Henry, L.A. (1994). Working memory span and phonological awareness tasks as predictors of early reading ability. *Journal of Experimental Child Psychology, 58*, 88-111.
- Lehto, J., Juujarvi, P., Kooistra, L., & Pulkkinen, L. (2003). Dimensions of executive functioning: Evidence from children. *British Journal of Developmental Psychology, 21*, 59–80.
- Menghini, D., Addona, F., Costanzo, F., & Vicari, S. (2010). Executive function in individuals with Williams syndrome. *Journal of Intellectual Disability Research, 54*, 418-432.
- Milner, A. D., & Goodale, M. A. (1995). *The visual brain in action*. Oxford: Oxford University Press.
- Miyake, A., Friedman, N.P., Emerson, M.J., Witzki, A.H., Howerter, A., & Wager, T.D. (2000). The unity and diversity of executive functions and their contributions to complex “frontal lobe” tasks: A latent variable analysis. *Cognitive Psychology, 41*, 49–100.
- Newcorn, J.H., Halperin, J.M., Jensen, P.S., Abikoff, H.B., Arnold, L.E., Cantwell, D.P., Conners, C.K., Elliott, G.R., Epstein, J.N., Greenhill, L.L., Hechtman, L., Hinshaw, S.P., Hoza, B., Kraemer, H.C., Pelham, W.E., Severe, J.B., Swanson, J.M., Wells, K.C., Wigal, T., & Vitiello, B. (2001). Symptom profiles in children with ADHD: Effects of comorbidity and gender. *Journal of American Academy for Child and Adolescent Psychiatry, 40*, 137–146.

- Noble, K.G., McCandliss, B.D., & Farah, M.J. (2007). Socioeconomic gradients predict individual differences in neurocognitive abilities. *Developmental Science, 10*, 464–480.
- Pani, J.R., Mervis, C.B., & Robinson, B.F. (1999). Global spatial organisation by individuals with Williams syndrome. *Psychological Science, 10*, 454-458.
- Pennington, B.F., Moon, J., Edgin, J., Stedron, J., & Nadel, L. (2003). The neuropsychology of Down syndrome: evidence for hippocampal dysfunction. *Child Development, 74*, 75-93.
- Porter, M.A., Coltheart, M., & Langdon, R. (2007). The neuropsychological basis of hypersociability in Williams and Down syndrome. *Neuropsychologia, 45*, 2839-2849.
- Rhodes, S.M., Riby, D.M., Park, J., Fraser, E., & Campbell, L.E. (2010). Executive neuropsychological functioning in individuals with Williams syndrome. *Neuropsychologia, 48*, 1216-1226.
- Robinson, B.F., Mervis, C.B., & Robinson, B.W. (2003). The roles of verbal short-term memory and working memory in the acquisition of grammar by children with Williams syndrome. *Developmental Neuropsychology, 23*, 13–31.
- Roid, G.H. (2003). *Stanford-Binet Intelligence Scales, Fifth Edition*. Itasca, IL: Riverside Publishing.
- Rowe, J., Lavender, A., & Turk, V. (2006). Cognitive executive function in Down's syndrome. *British Journal of Clinical Psychology, 45*, 5-17.
- Russell, J., Jarrold, C. & Hood, B. (1999). Two intact executive capacities in children with autism: Implications for the core executive dysfunctions in the disorder. *Journal of Autism and Developmental Disorders, 29*, 103-112.

- Snodgrass, J.G., & Vanderwart, M. (1980). A standardized set of 260 pictures: Norms for name agreement, image agreement, familiarity, and visual complexity. *Journal of Experimental Psychology: Human Learning and Memory*, 6, 174-215.
- St Clair-Thompson, H.L., & Gathercole, S.E. (2006). Executive functions and achievements in school: Shifting, updating, inhibition, and working memory. *Quarterly Journal of Experimental Psychology*, 59, 745–759.
- Talwar, V., Carlson, S.M., & Lee, K. (2009). Effects of a punitive environment on West African children’s executive functioning: A natural experiment. In K. Lee and A. D. Evans (Chairs), *The Development of Executive Functioning in Different Cultures*. Paper symposium presented at the biennial meeting of the Society for Research in Child Development, Denver, CO.
- Tarling, K., Perkins, M.R., & Stojanovik, V. (2006). Conversational success in Williams syndrome: Communication in the face of cognitive and linguistic limitations. *Clinical Linguistics and Phonetics*, 20, 583-590.
- van der Geest, J. N., Lagers-van Haselen, G. C., van Hagen, J. M., Govaerts, L. C., de Coo, I. F., de Zeeuw, C. I., & Frens, M.A. (2004). Saccade dysmetria in Williams-Beuren syndrome. *Neuropsychologia*, 42, 569–576.
- Vicari, S. (2006). Motor development and neuropsychological patterns in persons with Down syndrome. *Behavior Genetics*, 36, 355-364.
- Vicari, S., Carlesimo, G. A., & Caltagirone, C. (1995). Short-term memory in persons with intellectual disabilities and Down syndrome. *Journal of Intellectual Disability Research*, 39, 532–537.

Vicari, S., Caselli, M.C., & Tonucci, F. (2000). Early language development in Italian children with Down syndrome: asynchrony of lexical and morphosyntactic abilities.

Neuropsychologia, 38, 634-644.

Visu-Petra, L., Benga, O., Tincaş, I., & Miclea, M. (2007). Visual-spatial processing in children and adolescents with Down's syndrome: a computerized assessment of memory

skills. *Journal of Intellectual Disability Research*, 51, 942-952.

Wallace, G.L., Silvers, J.A., Martin, A., & Kenworthy, L.E. (2009). Brief report: Further

evidence for inner speech deficits in autism spectrum disorders. *Journal of Autism and Developmental Disorders*, 39, 1735-1739.

Zelazo, P.D., Burack, J.A., Benedetto, E., & Frye, D. (1996). Theory of mind and rule use in individuals with Down's syndrome: A test of the uniqueness and specificity claims.

Journal of Child Psychology & Psychiatry, 37, 479-484.

Table 1 Summary of means/SDs/ranges for age, IQ and short-term memory variables: individuals with Williams syndrome (WS), Down syndrome (DS) and typical development (TD).

Variable/group	WS (n=24; 11 males)	DS (n=25; 10 males)	TD (n=26; 16 males)
Age (months)	163.08 (36.33) (97-227)	163.72 (31.62) (124-227)	73.69 (11.65) (60-96)
ABIQ verbal raw	27.17 (4.30) (21-41)	23.88 (3.36) (18-30)	26.46 (3.11) (21-32)
ABIQ non-verbal raw	15.00 (3.36) (9-22)	14.08 (3.73) (7-26)	14.50 (4.64) (8-24)
ABIQ overall MA (months)	80.92 (13.18) (66-120)	72.32 (11.15) (47-92)	78.31 (14.18) (59-107)

ABIQ, Stanford-Binet Abbreviated Battery; MA, mental age.

Figure 1: Example of a three-picture array used in the Odd One Out test.

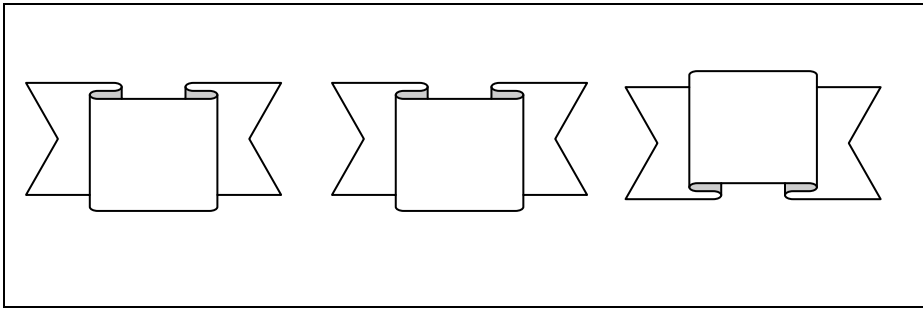

Table 2 Summary of means/SDs and ranges for executive functioning measures for individuals with Williams syndrome (WS), Down syndrome (DS) and typical development (TD).

EF measure/group	WS	DS	TD
ELWM verbal correct	8.17 (2.76) (4-13)	6.00 (1.55) (2-10)	8.81 (2.90) (3-14)
ELWM visuospatial correct	7.54 (3.16) (0-14)	10.00 (3.67) (3-18)	9.88 (4.22) (6-22)
Inhibition verbal errors	9.17 (7.07) (2-29)	7.08 (4.44) (1-21)	5.58 (3.21) (1-13)
Inhibition verbal time (s)	127.99 (22.08) (93.39-189.08)	137.74 (13.85) (114.20-170.60)	136.64 (20.05) (104.55-193.47)
Inhibition visuospatial errors	22.09 (7.79) (8-37)	12.67 (4.38) (6-25)	17.85 (4.46) (8-26)
Inhibition visuospatial time (s)	199.73 (35.95) (144.34-272.42)	182.62 (18.99) (154.78-222.02)	188.74 (26.47) (155.14-257.66)
Fluency verbal correct	25.25 (8.93) (11-48)	23.76 (8.57) (8-46)	22.73 (7.41) (8-36)
Fluency verbal repetitions	6.75 (7.59) (2-38)	7.44 (4.12) (2-19)	5.77 (5.08) (2-29)
Fluency visuospatial correct	7.13 (2.77) (3-13)	11.04 (4.60) (3-18)	12.19 (4.38) (4-20)
Fluency visuospatial repetitions	5.63 (4.68) (0-17)	5.24 (3.80) (0-14)	4.85 (3.55) (0-13)
Set-shifting verbal correct cost	2.83 (2.79) (-3.5-8.5)	3.20 (3.14) (-2.5-10)	1.67 (3.35) (-3-11)
Set-shifting verbal repetition	0.29 (2.74)	-0.16 (2.66)	-1.00 (1.83)

cost	(-4.5-6.5)	(-4.5-4)	(-6.5-2)
Set-shifting visuospatial correct cost	0.81 (1.27) (-1-4)	1.32 (2.60) (-3.5-6.5)	1.71 (2.14) (-3-8)
Set-shifting visuospatial repetition cost	-1.31 (2.48) (-5.5-5.5)	-1.42 (1.91) (-5.5-2.5)	-1.08 (1.78) (-4.5-2.5)

Table 3 Summary of regression models predicting performance on each executive function (EF) measure. In each model, three predictor variables were entered in a block at Step 1 (age, verbal IQ, non-verbal IQ; note Step 1 is not shown). Modality-specific STM variables were also entered at Step 1 of the ELWM models. Two further dummy-coded group variables were entered at Step 2 (WS vs. TD group, DS vs. TD group). The information provided about each model comprises total variance accounted for (Total R²), standardised beta values for each predictor variable and change in R². Significance is indicated where relevant.

EF measure	Total R ²	β Age	β VIQ raw	β NVIQ raw	β WS vs TD	β DS vs TD	ΔR^2 ; Step 2
ELWM verbal	.36	.28	.27*	.11	-.37	-.63**	.09**
ELWM visuospatial	.47	.85***	-.26*	.34**	-.92***	-.66**	.22**
Inhibition verbal errors	.26	-.28	-.08	-.31*	.54*	.31	.10*
Inhibition verbal time	.31	-.13	-.29*	-.24*	-.09	.11	.03
Inhibition visuospatial errors	.24	-.04	.24*	-.40***	.32	-.26	.22***
Inhibition visuospatial time	.16	-.37	-.14	-.06	.50*	.16	.12**
Fluency verbal correct	.23	.36	.32*	.09	-.18	-.13	.01
Fluency verbal repetitions	.11	.12	-.23	.01	-.08	.10	.02
Fluency visuospatial correct	.41	.20	.12	.30**	-.72***	-.24	.24***
Fluency visuospatial repetitions	.03	.20	.04	-.16	-.10	-.11	.00
Set-shifting verbal correct	.10	.08	.07	.17	.09	.20	.01
Set-shifting verbal repetitions	.17	-.70**	.15	.01	.80**	.79**	.16**
Set-shifting visuospatial correct	.04	-.12	-.05	.04	-.10	-.00	.01

Set-shifting visuospatial repetitions	.04	-.12	-.13	.15	-.03	-.02	.00
---------------------------------------	-----	------	------	-----	------	------	-----

VIQ, verbal IQ; NVIQ, non-verbal IQ; WS, Williams syndrome; DS, down syndrome; TD, typically developing.

* $p < .05$; ** $p < .01$; *** $p < .001$.