



City Research Online

City St George's, University of London

Citation: Hassani, V., Morris, A., Ibrahim, Z., Abubakar, I., Mehrabi, H. & O'Brien, R. (2020). A Mathematical Model for A Cladding Fastener to Estimate the Maximum Pull-Out Force Capacity. *Journal of Physics: Conference Series*, 1529(5), 052053. doi: 10.1088/1742-6596/1529/5/052053

This is the published version of the paper.

This version of the publication may differ from the final published version. To cite this item please consult the publisher's version.

Permanent repository link: <https://openaccess.city.ac.uk/id/eprint/33613/>

Link to published version: <https://doi.org/10.1088/1742-6596/1529/5/052053>

Copyright and Reuse: Copyright and Moral Rights remain with the author(s) and/or copyright holders. Copies of full items can be used for personal research or study, educational, or not-for-profit purposes without prior permission or charge, unless otherwise indicated, provided that the authors, title and full bibliographic details are credited, a hyperlink and/or URL is given for the original metadata page and the content is not changed in any way. For full details of reuse please refer to [City Research Online policy](#).

PAPER • OPEN ACCESS

A Mathematical Model for A Cladding Fastener to Estimate the Maximum Pull-Out Force Capacity

To cite this article: Vahid Hassani *et al* 2020 *J. Phys.: Conf. Ser.* **1529** 052053

View the [article online](#) for updates and enhancements.

You may also like

- [Train-based differential eddy current sensor system for rail fastener detection](#)
Praneeth Chandran, Matti Rantatalo, Johan Odelius et al.
- [A railway fastener inspection method based on lightweight network](#)
Yue Wang, Ji Wang, Shubin Zheng et al.
- [Quantification of Accelerated Corrosion Testing of Coated AA7075-T6](#)
Zhicao Feng, G. S. Frankel and C. A. Matzdorf

PRIME
PACIFIC RIM MEETING
ON ELECTROCHEMICAL
AND SOLID STATE SCIENCE

HONOLULU, HI
October 6-11, 2024

Joint International Meeting of
The Electrochemical Society of Japan
(ECSJ)
The Korean Electrochemical Society
(KECS)
The Electrochemical Society (ECS)

Early Registration Deadline:
September 3, 2024

**MAKE YOUR PLANS
NOW!**

A Mathematical Model for A Cladding Fastener to Estimate the Maximum Pull-Out Force Capacity

Vahid Hassani¹, Adrian Morris¹, Zunaidi Ibrahim¹, Ismail Abubakar¹, Hamid Mehrabi¹, Roger O'Brien¹

¹Sustainable Advanced Manufacturing, Sunderland University, UK, St Peter's Campus, Sunderland, SR6 0DD, United Kingdom

Abstract. In the last few years, considerable attention has been paid to the roof cladding systems due to their progressive use in the construction of low-rise buildings. The design of such systems has been gaining importance since they are subjected to severe damage and failure caused by high wind events, particularly at their fastener connection points. To offer a solution for predicting the maximum pull-out force capacity of cladding fasteners, this article presents a mathematical model for a fastener made of high strength steel austenitic 316. In this model, the two basic parameters of the fastener, namely the thread depth and the thread angle are included as the main elements of the contact surface between threads and the low carbon mild steel batten/purlin sheets. This mathematical model will be proposed to estimate the maximum pull-out force capacity of the cladding fasteners made of cold-formed A2 316 stainless steel. After finding the parameters of the mathematical model by using an optimization method based on a genetic algorithm (GA), a comparison will be made between the mean estimation error of the new model and the formerly proposed ones.

Keywords: Cladding Fastener; Pull-out Force; Mathematical Model; Thread Engagement Ratio; Estimation Error

1. Introduction

High wind events such as a hurricane, cyclones, etc. can create severe damage to the roof cladding systems. The consequence of the roof cladding system damage might be a progressive collapse of the entire building and irreparable failures. As a result, the roof cladding systems have to be structurally investigated from two viewpoints, namely cladding system failure and cladding fasteners failure. The former one could be known as the failure that occurs in the entire system including claddings and fasteners, while the latter one is a failure that often takes place solely for the fasteners of such systems.

From the aspect of load application, these systems have been analyzed both statically and dynamically. Several studies have appeared in recent years documenting the static and dynamic failures of the roof cladding systems. For instance, among all types of failures occurring in the roofing systems, localized pull-out failures have special importance due to their high potential for initiating the extensive loss of roofing systems under high wind uplift loads. Recent studies have also confirmed that the occurrences of localized pull-out failures that lead to major failures of the entire structure [1,2]. To predict the pull-out force capacity, some approaches have been proposed by researchers. Sivapathasundaram and Mahendran developed a mathematical model in which the sheet thickness and geometry of cladding fasteners were taken into account with an improvement of estimation error compared to the previous models [3]. Similarly, an improved formula was proposed in terms of the thickness and ultimate tensile strength of the steel cladding system together with considering the diameters of the screw head or washer [4]. In this research, the details of the investigation and its results were presented. Alternatively, in a different study, the shear behavior of cladding fasteners was

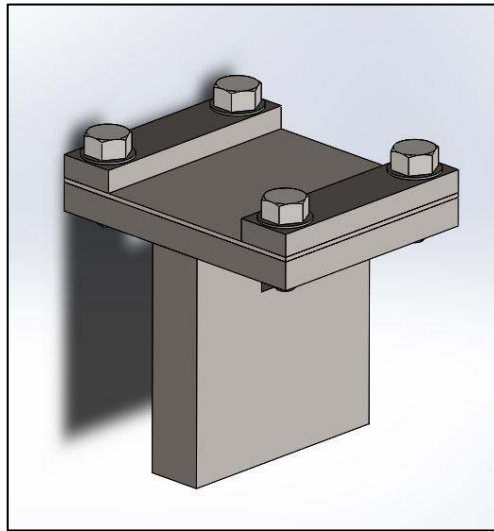

Figure 2. The Test Sample Bolted into the Bottom Jaw

Care is taken to make sure that the screw is inserted close to the center of the test sample as possible using marks on the test sample and measured spacers designed to hold the upper plate in the correct position. The upper plate is then bolted to an upright designed to be held in the upper jaws of the tensile test machine as shown in Figure 3. The fixture is then placed between the upper and lower jaws of the tensile test machine as shown in Figure 4 and the two halves pulled apart until the screwed joint failed.

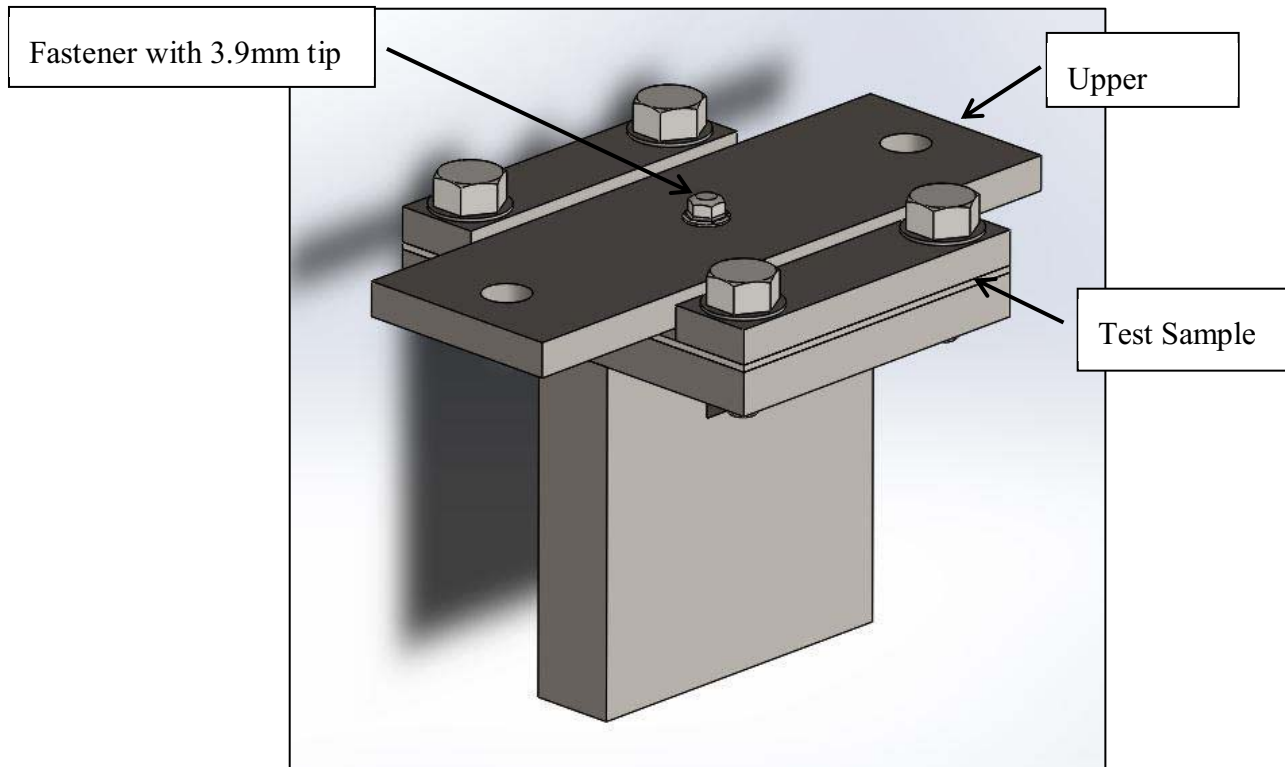

Figure 3. Upper Plate attached using Cladding Fastener

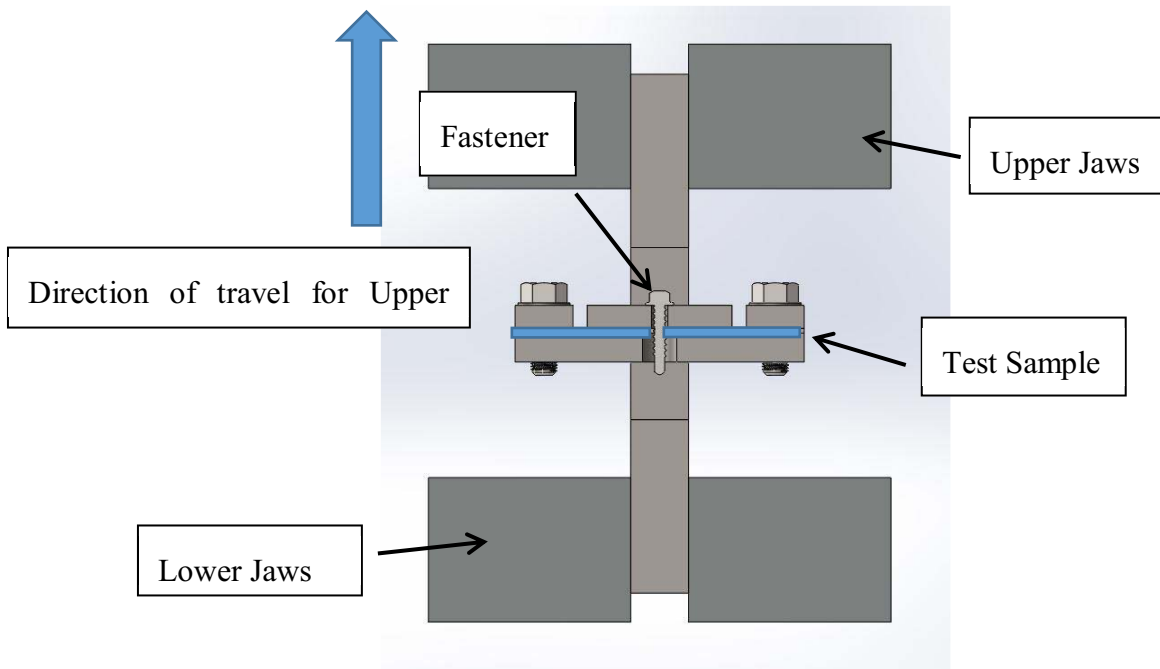

Figure 4. Schematic of Tensile Test Machine

These tests were carried out on a Zwick Z010 tensile test machine calibrated to 10kN. Six different steel sheet thicknesses were tested to evaluate the maximum pull-out force capacity. For each test, a force and extension curve was plotted and the maximum pull-out force capacity was obtained. Each test was repeated five times and the mathematical average calculated. The results are shown in Table 1 and Figure 5.

Table 1. Results of the Experiments

Steel Sheet Thickness (mm)	Average Maximum Pull-out Force Capacity (kN)
1.2	3.22
1.4	3.85
1.6	4.47
1.8	5.1
2	6.13
2.5	7.69

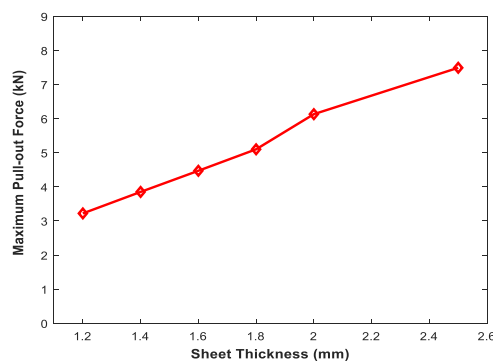

Figure 5. Maximum Pull-out Force (kN) Variation with Steel Sheet Thickness (mm)

The geometry of a typical cladding fastener is shown in figures 6a and 6b. The geometry of the fastener contains five parameters that form its main configuration. These parameters namely, outer diameter or d_{max} , inner diameter or d , pitch or p , the thread depth or $d_{max}-d$, and the thread angle or θ are shown in Figure 6b.

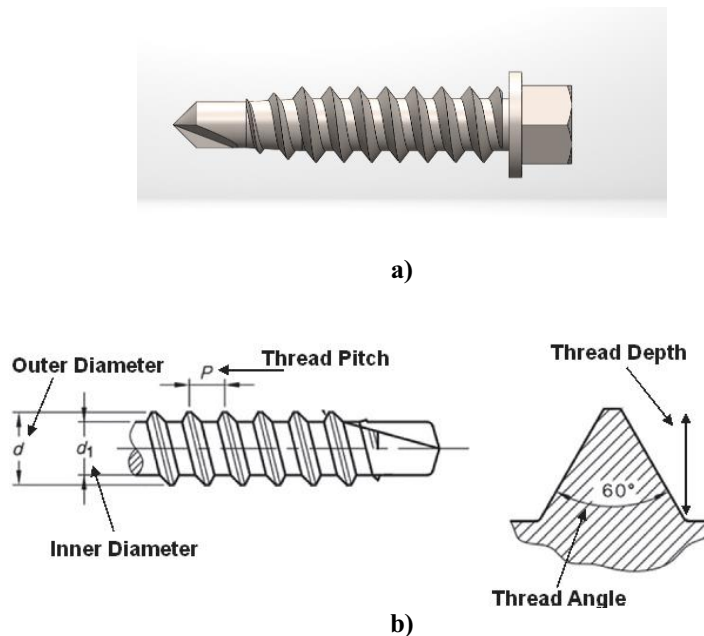

Figure 6. a) A Typical Cladding Fastener and its Geometry Parameters, b) Main Parameters of a Cladding Fastener, Thread Depth, Thread Angle, Outer Diameter, Inner Diameter, and Thread Pitch.

3. Mathematical Model

In this section, a mathematical model, represented in Equation (1), is presented to estimate the maximum pull-out force of the high strength steel fasteners, P_u . The model is the modified version of the former model proposed by Sivapathasundaram and Mahendran [3] that is represented in Equation (2). Prior to [3], the pull-out force capacity of the cold-formed steels used to be predicted by using the design Equation (3), as standardized by Eurocode 3 Part 1-3 (EN 1993-1-3, 2006). In the proposed model in this study, some parameters are chosen as key parameters that play a significant role in the amount of pull-out force capacity of the sheet-cladding fastener assembly. In all equations, t stands for steel sheet thickness, P denotes the pitch value of the fastener which is chosen 1.82mm in this study, d_{max} is external diameter which is 6.74mm, f_u represents the ultimate tensile strength of A653 low carbon mild steel that is approximately 550 MPa, d is chosen slightly larger than the internal diameter of the fastener, i.e. 5.3mm and θ denotes the thread angle which is chosen 30° . As discussed earlier, this model has some advantages over the previous ones in the sense that fastener pitch, P , and the thread angle θ have been taken into account in it. The last term of Equation (1), namely the thread engagement ratio is to demonstrate the effect of the thread angle at the maximum value of the pull-out force.

$$P_u = A(t)^B (d_{max})^C f_u \left(\frac{d_{max} - d}{P} \right)^D \left(\frac{t - (P - 2tg\theta(\frac{d_{max} - d}{2}))}{2tg\theta(\frac{d_{max} - d}{2})} \right)^E \quad (1)$$

$$P_u = 1.62t^{1.3} d^{0.7} f_u [(d_{max} - d) / P]^{0.3} \quad (2)$$

$$P_u = 0.65t.d.f_u \quad (3)$$

This term is written as $\left(\frac{t - (P - 2tg\theta(\frac{d_{max} - d}{2}))}{2tg\theta(\frac{d_{max} - d}{2})}\right)^E$ and graphically illustrated in Figure 7.

This term is used to estimate the ratio of projected length of the engaged length between steel sheet and fastener (shown by red lines in Figure 7) to the overall thread length, 'L'. Regarding the values of the fastener parameters for this particular class, Equation (1) is valid for the sheet thicknesses, $t/P < 1.37$, $t/P > 0.66$ and $20^\circ < \theta < 40^\circ$. As mentioned above, this model takes into account the fastener pitch, P as it does not appear in the model proposed by Eurocode 3 and also the thread angle, θ that is not observed in Equation (2).

The values A, B, C, D, and E have to be obtained in a separate analysis by using GA. For this purpose, one experiment was conducted on the steel sheet with a thickness of 1.6mm. The average pull-out force obtained for the sheet with $t=1.6\text{mm}$ was 4400 N by performing five experiments. By using this average value, the model parameters A, B, C, D, and E were obtained using the following objective function,

$$\text{Obj. Function: } 0.5(4400 - P_u)^2 \tag{4}$$

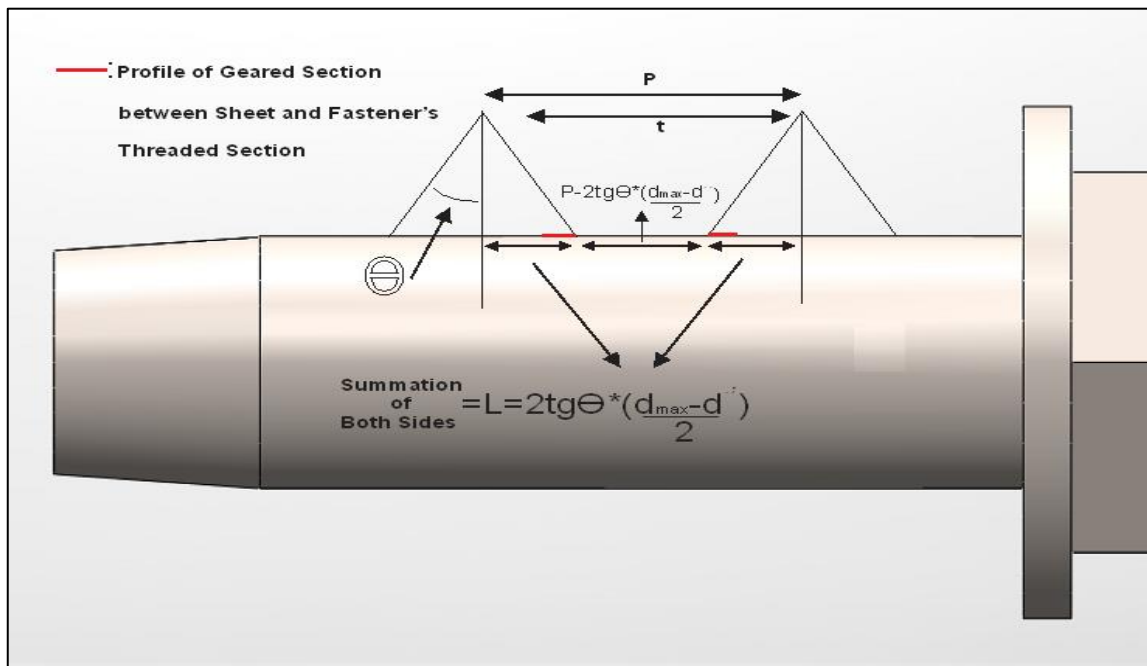

Figure 7. Graphical Illustration of the Thread Engagement Ratio (the Ratio of Summation of Length of Red Lines to Thread Length, L) for the Cross-Section of the Fastener.

Where 4400 is the average value of the maximum pull-out force for the steel sheet with 1.6mm. By minimizing the objective function above, the parameter values were obtained as $A=1.62$, $B=1.35$, $C=0.65$, $D=1.1$, and $E=0.06$ with 1.6% overestimate of 4470 N compared to the average value of 4400 N. Note shall be taken that since the unit of Equation (1) is Newton (N), the summation of $B+C=2$ has to be defined as equality constraint for the optimization process. In order to validate the model obtained, we obtained 3580 N when the sheet thickness is 1.4mm that has 5.67% underestimate compared to the average value of 3800 N.

After obtaining the final equation, one comparison was made between the proposed model in this study and the two former models that are represented by equations (2) and (3) based on the experimental data shown in Figure 5. As can be seen in Figure 8, the new model seems to be more performative in terms of the maximum pull-out force prediction compared to its previous

counterparts. The mean estimation error obtained for the range of sheet thicknesses from 1.2mm to 2.5 mm, was 259.3 N for the new model, 1567 N for Sivapathasundaram and Mahendran model (Mathematics Model #2 in Figure 8) and 826.62 N for Eurocode 3 model (Mathematics Model #1 in Figure 8), respectively.

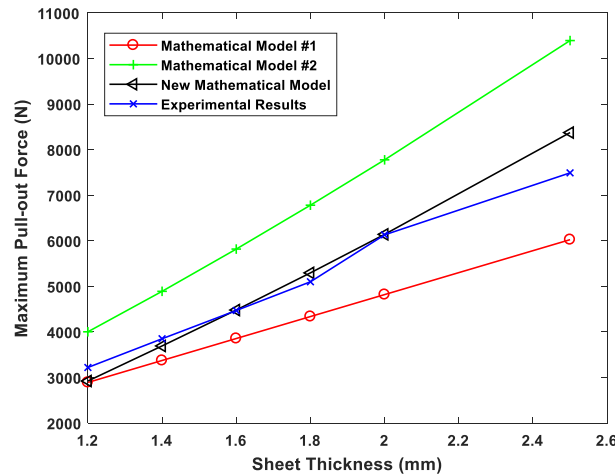

Figure 8. Comparison between the New Model and the Previous Models based on the Experimental Data

4. Limitations and future work

The results presented are indicative of fastener performance when stalled using a screwdriver set up to the manufacturer's recommended settings. Impact tools were not used in any of these tests. In real life situations the skill of the operator and environmental conditions are expected to affect the performance of any fastener. This should be taken into consideration when reviewing the results. Finally, only one grade of material was used and it is likely that alternative steel grades will affect performance, as will alternative materials such as GRP. Further work is required to validate the general applicability of the proposed model to a wide range of materials.

5. Conclusion

This paper has presented the details of an experimental study on a commonly used roof fastener made of austenitic steel 316. Firstly, an experimental set-up was designed to conduct the experiments on the steel-fastener assembly with different steel sheet thicknesses. Then, by using the experimental data and considering the previous models, a new mathematical model was proposed by which the two basic parameters of the fastener, namely the thread depth and the thread angle were taken into account. Finally, a simulation was performed, and the results satisfactorily demonstrated a good agreement between the predictions of the maximum pull-out force by the new model in comparison with the previous ones.

Acknowledgments

This project is a Sustainable Advanced Manufacturing (SAM) Project to support manufacturing process development for Niratec Ltd. Special thanks to all members of SAM, Sunderland University, David Land and Brian Watson (Niratec Ltd.) for providing the research expertise and support for this project. This research was funded by the European Regional Development Fund (ERDF) for SMEs within the manufacturing sector based in the North East LEP area of the UK.

References

- [1]. D.Henderson, J.Ginger, C.Leitch, G.Boughton, D.Falck, Tropical Cyclone Larry Damage to Buildings in the Innisfail Area, Technical Report 51, Cyclone Testing Station, James Cook University, Townsville, Australia, (2006).

- [2]. G.N.Boughton, D.J.Falck, Tropical Cyclone George Damage to Buildings in the Port Hedland Area, Technical Report 52, Cyclone Testing Station, James Cook University, Townsville, Australia (2007).
- [3]. M. Sivapathasundaram, M. Mahendran, New Pull-Out Capacity Equations for the Design of Screw Fastener Connections in Steel Cladding Systems, Thin-Walled Structures, 122 (2018) 439-451.
- [4]. M.Mahendran, Pull-Through Strength of High Tensile Steel Cladding Systems, Australian Structural Engineering Transactions, 2 (1999), 37-50.
- [5]. G. De Matteis, R.Landolfo, Mechanical Fasteners for Cladding Sandwich Panels: Interpretative Models for Shear Behavior, 35(1999) 61-79.
- [6]. N. Korcz-Konkol, E. Urbanska-Galewska, Influence of Sheet/Purlin Fasteners Spacing on Shear Flexibility of the Diaphragm, MATEC web of Conferences 219, 02007, BalCon, (2018).
- [7]. D. Mahaarachchi, M. Mahendran, Finite Element Analysis and Design of Crest-Fixed Trapezoidal Steel Claddings with Wide Pans subject to Pull-Through Failures, Engineering Structures, 26 (2004) 1547-1559.
- [8]. V. Hariraj, W. K. Vikneswaran, and Z. Ibrahim, "Fuzzy Multi-Layer SVM Classification," *Int. J. Mech. Eng. Technol. Vol.*, vol. 9, no. 8, pp. 1281–1299, 2018.
- [9]. Z. Ibrahim, R. Nagarajan, M. Rizon, D. Hazry, D. Ruslizam, and C. O. Azlin, "Electromyography signal based for intelligent prosthesis design," in IFMBE Proceedings, 2008, vol. 21 IFMBE, no. 1, pp. 187–190.
- [10]. I. Zunaidi, N. Kato, Y. Nomura, and H. Matsui, "Path planning based on geographical features information for an autonomous mobile robot," *Artif. Life Robot.*, vol. 10, no. 2, pp. 149–156, Nov. 2006.
- [11]. W. A. Mustafa, W. Khairunizam, Z. Ibrahim, A. B. Shahriman, and Z. M. Razlan, "Improved Feng Binarization Based on Max-Mean Technique on Document Image," in 2018 International Conference on Computational Approach in Smart Systems Design and Applications, ICASSDA 2018, 2018.
- [12]. W. A. Mustafa, H. Aziz, W. Khairunizam, Z. Ibrahim, A. B. Shahriman, and Z. M. Razlan, "Review of Different Binarization Approaches on Degraded Document Images," in 2018 International Conference on Computational Approach in Smart Systems Design and Applications, ICASSDA 2018, 2018.
- [13]. H. Halin et al., "Investigation of steering wheel control of an electric buggy car for designing fuzzy controller," in Lecture Notes in Mechanical Engineering, no. 9789811087875, Pleiades Publishing, 2018, pp. 459–468
- [14]. V. Hassani, Z. Khabazi, F. Raspall, C. Banon, D. W. Rosen, Form-Finding and Structural Shape Optimization of the Metal 3D-Printed Multi-Branch Node with Complex Geometry, *Computer-Aided Design and Applications*, 17 (2019) 205-225.