



City Research Online

City, University of London Institutional Repository

Citation: Constable, P. A. (2014). A perspective on the mechanism of the light-rise of the electro-oculogram. *Investigative Ophthalmology and Visual Science*, 55(4), pp. 2669-2673. doi: 10.1167/iovs.14-13979

This is the draft version of the paper.

This version of the publication may differ from the final published version.

Permanent repository link: <http://openaccess.city.ac.uk/3638/>

Link to published version: <http://dx.doi.org/10.1167/iovs.14-13979>

Copyright and reuse: City Research Online aims to make research outputs of City, University of London available to a wider audience. Copyright and Moral Rights remain with the author(s) and/or copyright holders. URLs from City Research Online may be freely distributed and linked to.

City Research Online:

<http://openaccess.city.ac.uk/>

publications@city.ac.uk

A perspective on the mechanism of the light-rise of the electro-oculogram

Paul A Constable

Applied Vision Research Centre

City University London

Northampton Square

London EC1V 0HB

United Kingdom

Paul.Constable.1@city.ac.uk

Tel: 00 44 207 040 4334

Fax: 00 44 207 040 8494

Key words

Electro-oculogram, Light-rise, Inositol tri-phosphate

Abstract

The light-rise of the electro-oculogram is believed to originate from a substance released from the rods after dark adaptation. The identity of this 'elusive' light-rise substance has not been demonstrated and therefore a new perspective on the light-rise is presented. The light-rise is caused by the depolarization of the basolateral membrane of the retinal pigment epithelium has become clearer in the last decade with the identification of calcium as the intracellular secondary messenger and the role of bestrophin as a regulator of intracellular stores of calcium and controlling the cytosolic calcium levels through L-type calcium channels. The light-rise depends upon a change from darkness to light which triggers the intracellular cascade resulting in the depolarization of the basolateral membrane. The same intracellular signalling molecules- notably calcium and inositol tri-phosphate (IP3) are strongly implicated in this cascade. Recent studies have now led to a clearer understanding of the roles and functions of the ion channels and their contribution to the light-rise with IP3 regulating the release of calcium for intracellular stores. Given that calcium and IP3 are also regulators of phagocytosis, and that the initiation of rod outer segment phagocytosis is initiated with light-onset, it may be that the light-rise is generated in response to this physiological event. Therefore, the putative light-rise substance may not be released by the rods but follows directly from IP3 release from the RPE's phospholipid membrane following the onset of light and the initiation of phagocytosis- The light rise substance, could be considered to be light itself.

Background

The standing potential of the eye is generated by the trans-epithelial potential across the retinal pigment epithelium (RPE) ¹. The standing potential changes with retinal illumination with a fall to a dark-trough following the offset of illumination and a light-rise following re-illumination ². The ratio of the dark-trough to the light-rise is used clinically to assess RPE function and is known as the Arden ratio ³. A reduction in the Arden ratio is associated with conditions affecting the RPE such as, Best's maculopathy ⁴, chloroquine retinopathy ⁵ and more recently vigabatrin therapy ⁶. The RPE is vital for visual function ⁷ and the EOG

remains the sole clinical test that is able to assess its integrity, and therefore an understanding of the mechanism of the light-rise and may provide additional clinical uses for the EOG.

The original model for the origins of the light-rise is that a 'light-rise' substance is released by the rods that binds to an unknown receptor on the RPE which initiates a second messenger cascade within the RPE and which finally results in an increased basolateral chloride conductance⁸ that depolarizes the RPE and increases the recorded standing potential of the eyes. For review see Arden and Constable (2006)⁹, Candidates for the light-rise substance have been proposed such as dopamine¹⁰ and epinephrine¹¹. Purinergic signalling remains a possible mechanism for the light-rise with RPE cells being capable of secreting ATP through CFTR and vesicles across the apical membrane¹² with the degraded purines capable of elevating intracellular calcium¹³. ATP has been shown to be secreted across the apical membrane of human induced pluripotent stem cell lines¹⁴ and thus ATP or its degraded products remains a potential candidate as a light-rise substance. However, light would need to be implicated in increasing the secretion of ATP. The lack of a clearly demonstrated 'light-rise' substance that is released from the rods to initiate the slow potential changes across the RPE suggests that there may be an alternative mechanism for the light-rise.

There is now strong evidence that the second messenger involved in the generation of the light-rise is calcium. Individuals with cystic fibrosis show normal amplitudes in the light-rise which negates involvement of cyclic AMP as second messenger¹⁵. In addition the inhibition of L-type Calcium current with nifedipine alters the amplitude of the light-rise in man¹⁶. In addition to studies in man, the identification of L-type calcium channels in the RPE of rat¹⁷ and cultured human RPE cells¹⁸ that display similar Current-Voltage curve to the light-rise¹⁹ implies that these channels are responsible for the slow influx of calcium as the basolateral membrane depolarises. The calcium activated chloride channel (CCLA) that opens in

response to a rise in cytosolic calcium has, until recently been presumed to be bestrophin²⁰ owing to clinical findings in individuals carrying mutations in bestrophin 1 (*BEST1*). However, not all individuals with *BEST1* mutations display reduced light-rises²¹⁻²³.

The role of bestrophin has been difficult to fully explain until recently – for review see Strauss and Rosenthal (2005)²⁴. Bestrophin is now seen as a regulator of intracellular calcium stores rather than a calcium activated chloride channel²⁵. Earlier findings in rat models where mutant bestrophin was overexpressed did not reduce the light-rise as expected and led to doubts over bestrophin being the generator of the light rise²⁶. Further confusion arose with increases in the amplitude of the light-rise demonstrated in mouse models of Best's disease²⁷. A Calcium dependent chloride channel has been demonstrated in cultured canine RPE cells²⁸ and is also expressed in chick RPE²⁹. The Calcium activated chloride channel TMEM16A (ANO1) of the anoctamin family is widely expressed in epithelia where they regulate cell volume, apoptosis and proliferation³⁰. Knockout mice demonstrate decreased chloride secretion in multiple secretory epithelia³¹ and TMEM16A is expressed in mouse and human ocular epithelia³². Best1 and TMEM16A function as a micro domain in renal and lung epithelia and it is plausible that TMEM16A is the calcium activated chloride channel in the RPE that regulates cell volume whilst bestrophin regulates intracellular calcium stores. The main recent findings about the nature of bestrophin-1 are that the protein, is not expressed in the basolateral membrane as previously thought²⁰ but is associated with the endoplasmic reticulum where it regulates store operated calcium entry³³. The key recent findings are that bestrophin-1 co-localises with Stim-1 a protein found in the endoplasmic reticulum and whose role is to sense the levels of calcium stores. When stores are low Stim-1 may increase cytoplasmic concentrations of calcium for re-uptake into the endoplasmic reticulum through plasma membrane calcium channels such as Orai^{34,35} via a physical interaction³⁶. The finding that bestrophin-1 co-localises with Stim-1 and regulates store

operated calcium entry provides an elegant resolution to the confusion surrounding the role of bestrophin-1 in the RPE and the findings of normal light-rises in some individuals with Best's disease. Gomez et al (2013) were able to demonstrate that in the RPE bestrophin-1 regulates the majority of calcium entry to the cytosol following depletion of endoplasmic reticulum stores. The increase in intracellular calcium is through a direct interaction between the C-terminus of the L-type calcium channels in the plasma membranes and bestrophin-1 in the endoplasmic reticulum. In addition bestrophin-1 acts as a chloride channel by conducting chloride ions as the counter-ion into the endoplasmic reticulum to facilitate the re-uptake of calcium through the endoplasmic reticulum Ca-ATPase pump. The RPE cells also express the Stim-1/Orai channels that contribute less to the overall replenishment of cytosolic calcium following depletion of the stores^{30,31}.

Whilst the mechanism of the light-rise at the basolateral membrane of the RPE has become clearer – the existence of the light-rise substance that would initiate a release of stored calcium remains elusive. Furthermore, the explanation for the 'dark-trough' following the offset of light during the EOG has not been fully explained. One physiological process associated with the transition from dark to light is the initiation of phagocytosis that is increased by IP3³⁷ and turned off by calcium³⁸. Based upon the recent findings by Strauss's group the light-rise would follow a rise in IP3 which releases calcium from the endoplasmic reticulum. The transient fall in calcium stores would be sensed by bestrophin-1 that physically interacts with the L-type calcium channel in the RPE's basolateral membrane which allows a slow entry of calcium to the cytoplasm where it gates activates a calcium gated chloride channel to depolarise the membrane and initiate the light-rise phase. The chloride conductance must now be presumed to be carried by CCLA channels in the RPE. In darkness there are still dark –damped oscillations³ and these may be the result of baseline

fluctuations in store and cytoplasmic free calcium regulated by Stim-1/Orai channel's within the RPE.

The dark trough

When the EOG is recorded in darkness a series of dark oscillations occur³ with the first large trough used as the reference point for the magnitude of the light-rise. The underlying mechanism of the dark-trough has not been fully investigated. However, the nature of the dark oscillations that are similar to the damped oscillations seen when the EOG is recorded following light onset suggest that these dark oscillations may also be related to calcium signalling. Store operated calcium entry is regulated by bestrophin/L-type Ca^{2+} channels which provide the majority of store operated calcium entry control and Stim1/Orai interactions which play a smaller part in calcium re-uptake³³. In order for the standing potential to fall, there would need to be either a hyperpolarization of the basal membrane or a depolarization of the apical membrane³⁹. Given the slow nature of the dark oscillations with the minima reached at ~10 minutes, it would be unlikely that the changes in intracellular potassium activity that are related to the fast oscillations of the EOG would be responsible owing to their faster time course⁴⁰. Linking the dark oscillations to shedding and phagocytosis of cone outer segments may not be likely as in the Rhesus monkey, cone phagosomes are maximal at 5 hours after darkness⁴¹.

The slow nature of the dark oscillations may also be a result of decrease in IP3 generation following the off-set of light and a decrease in CCLA channel conductance resulting in a hyperpolarization of the basolateral membrane and a fall in the transepithelial potential after ~10 minutes. The rise from the dark trough minima and subsequent oscillations may be the result of smaller Stim1/Orai channel regulation of calcium uptake into the cytoplasm calcium stores although the origins of the dark oscillations will require further study. Their

importance is that the trans-epithelial potential of the RPE generates the standing potential and the trans epithelial potential is dependent upon the tight junction resistance⁴². Therefore, if the resistance of the RPE barrier were low then the standing potential at the onset of darkness may also be low or the relative ratio from the initial standing potential at the start of the EOG to the dark-trough minima may be reduced and a possible additional clinical measure to compare with the dark-trough to light-rise ratio.

The light-rise and rod phagocytosis

The shedding and subsequent phagocytosis of rod outer segments at light by the RPE involves many signalling pathways that are still being refined around the recognition, engulfment and final degradation of the phagolysosome. For review see Kevany & Palczewski (2010)⁴³. The entrainment of rod outer segment shedding to the circadian rhythm and initiated by light-onset has been demonstrated across species^{44,45}. Important recognition and binding receptors and ligands have been identified that enable phagocytosis of shed rod outer segments. The $\alpha\beta 5$ vitronectin receptor⁴⁶ and the scavenger CD36 receptor^{47,48} are involved in outer segment binding to the RPE. One retinal ligand for $\alpha\beta 5$ has been shown to be milk fat globule-EGF-factor 8 (MFG-E8): in mice lacking functional MFG-E8 the ability to phagocytose outer segments is lost the daily rhythm of up regulation and phosphorylation of Mertk as well as reduced retinal adhesion⁴⁹. Mertk was shown to be necessary for ingestion but not binding of rod outer segments in the RCS rat model of retinal dystrophy, although the RCS rat could ingest micro-beads⁵⁰⁻⁵². Thus Mertk is an RPE receptor that is required for the specific ingestion of rod outer segments. There is evidence that Gas6 and Protein S are the important ligands between Mertk and the rod outer segments that enables ingestion⁵³. The internalisation of the outer segment requires phosphorylation of Mertk and the mobilisation of focal adhesion kinases to the apical membrane of the RPE cell which enables engulfment of the outer segments^{54,55}. A second pathway that relies upon $\alpha\beta 5$ and MFG-E8 binding for F-actin redistribution to form the phagocytic cup is mediated by small GTP binding protein Rac1⁵⁴.

The generation of IP3 from light alone has been shown in isolated frog RPE cells using radiolabeled inositol ⁵⁶. The authors were to demonstrate that following one hour of dark adaption and 30 minutes of light the amount of recovered free inositol plus inositol phosphates increased by 86%. However, [³H]inositol-labelled IP3 had the highest increase with a 5.5 fold increase within the RPE cells. Therefore, light can induce polyphosphoinositide turnover and would provide a pathway in which IP3 increased in RPE cells following light-onset and the release of intracellular calcium stores and the steps leading to the light-rise without the need for a light-rise substance being released directly from the photoreceptors. See figure 1 from Rodriguez De'Turco et al (1992). In addition, the process of phagocytosis also results in an increase in IP3 by the hydrolysis of phosphatidylinositol bisphosphate following challenge with outer segments or polystyrene balls in cultured rat RPE cells but not in cultures of RCS rat where Mertk signalling is disrupted ^{52,57}. The potential light-rise substance may not originate from the rods but from the process of light driven production of IP3 from the phospholipid membrane and or the generation of IP3 to phosphorylate Mertk which is required for internalisation of the shed outer segments.

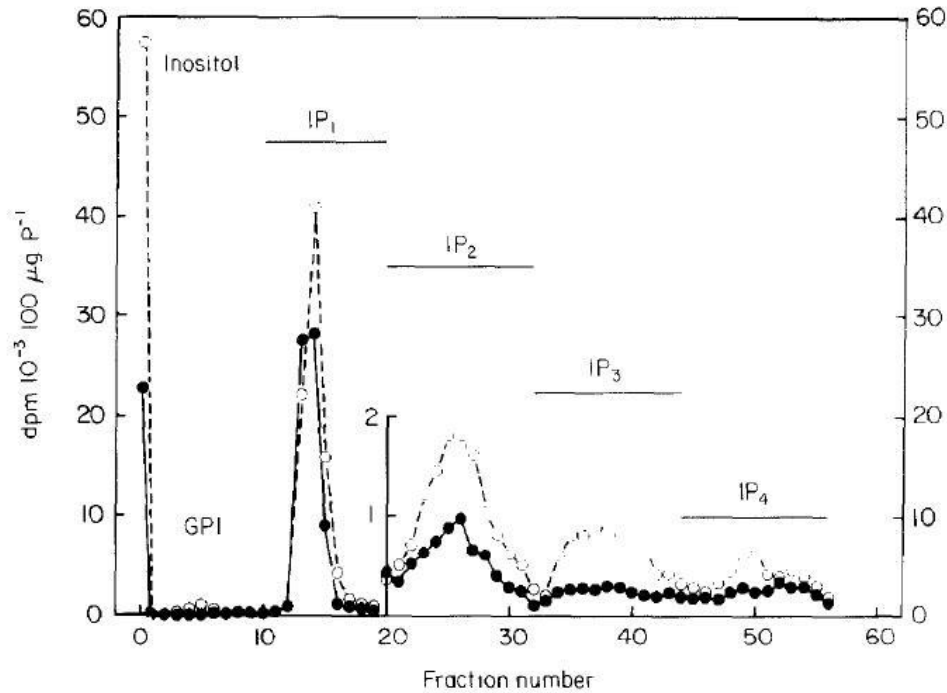

Figure 1 Showing an increase in IP3 production in frog RPE cells following 24 hours light then either 1 hour of dark adaption and thirty minutes light (open circles) or 30 minutes of continued darkness (closed circles). IP3 had the largest increase (5x) following light-onset. (Figure from Rodriguez De Turco et al (1992) reproduced courtesy of Springer.

Rather than a substance being released from the rods following light-onset it is possible that the intimate contact between the RPE and outer retina is essential for the generation of the light-rise. The integrity of the phospholipid bilayer and the cellular components of phagocytosis and in individuals with detached retinas where the light-rise is absent, this may be due to a disruption to the integrity of the phospholipid bilayer and phagocytic ability. RPE cells after detachment undergo morphological changes within 24 hours in cat⁵⁸ and de-differentiate⁵⁹ which may impact upon IP3 formation following light onset and the binding of outer segments to the RPE.

Revised Model of the Light-Rise

The light-rise may not require the release of a light-rise substance from the rods but depend upon an intact apical membrane that has PIP₂ that can be metabolised to IP₃ following illumination may be sufficient. . The lack of a light-rise in individuals with a retinal detachment may be due to morphological changes in the RPE following the separation of the RPE from the outer retina. Liberation of IP₃ from the RPE's membrane is a precursor to the phosphorylation of Mertk and is absent in the RCS rat where Mertk is affected.

Once IP₃ is formed then release of stored calcium from the endoplasmic reticulum via the IP₃-receptor would increase intracellular calcium and open calcium gated chloride channels in the basolateral membrane resulting in depolarization and an increase in the trans-epithelial potential. The depletion of stored calcium from the endoplasmic reticulum results in bestrophin – previously thought to be the basolateral calcium gated chloride channel responsible for the light-rise; instead operating as a regulator of intracellular stored calcium. Bestrophin through physical interaction with the L-type Calcium channel facilitates entry of calcium to the cytosol, for re-uptake by endoplasmic reticulum Ca-ATPase to replenish stored calcium. (See figure 2).

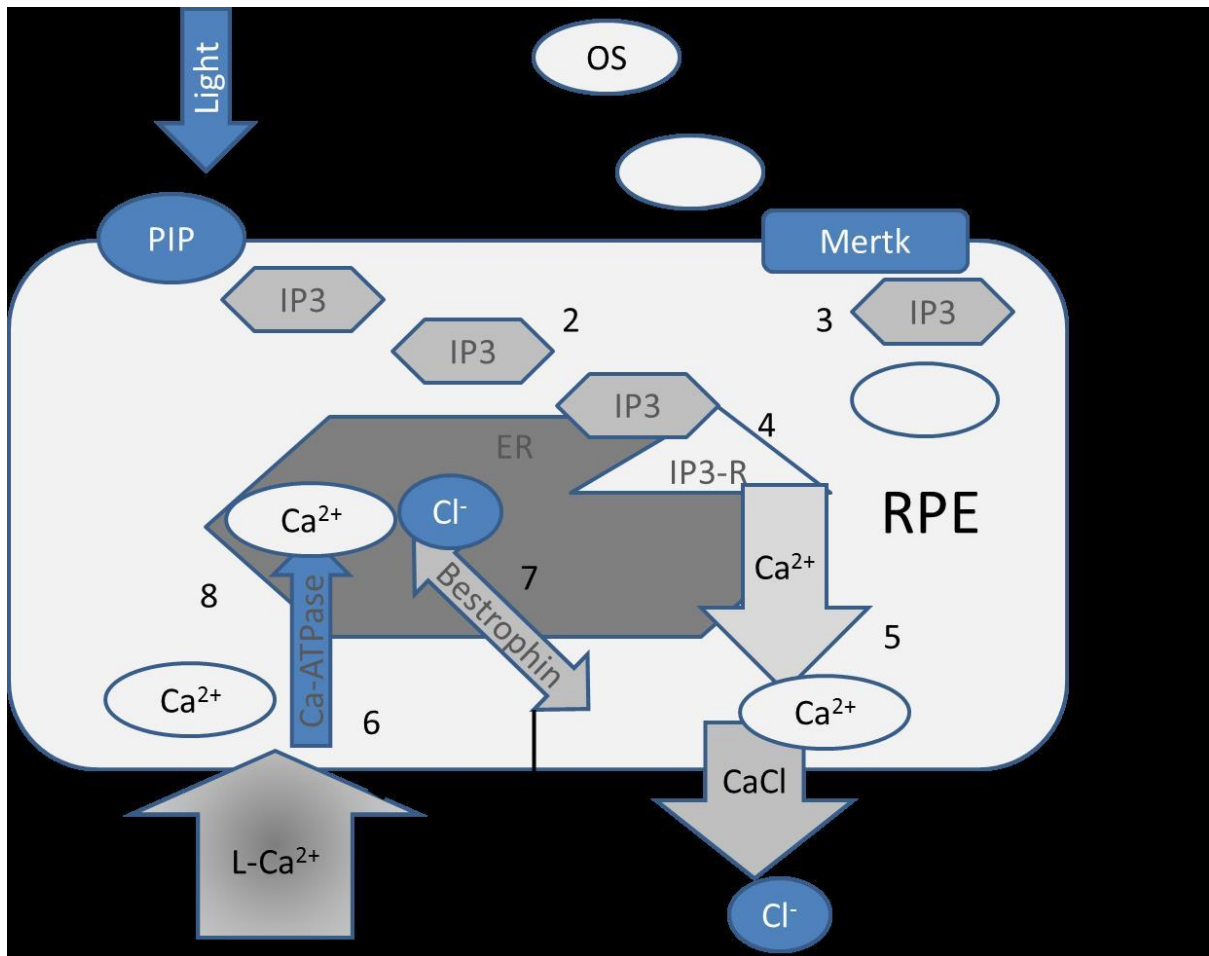

Figure 2 Possible mechanism for the light-rise based upon IP3 turnover following light-onset. (1) Light generates IP3 from the phospholipid membrane with phosphatidylinositol bisphosphate (PIP₂) as the pre-cursor. (2) IP3 is the intracellular second messenger that regulates phagocytosis and mobilisation of intracellular calcium stores. (3) IP3 is required for phosphorylation of Mertk which is required for internalisation of shed outer segments (OS). (4) IP3 binds to the IP3-Receptor on the endoplasmic reticulum (ER) which releases calcium so that $[Ca^{2+}]_{in}$ increases and in turn depletes stored calcium with the ER. (5) Calcium gates open a calcium gated chloride channel which is most likely TMEM16A; in the basolateral membrane of the RPE which increases basolateral chloride conductance and depolarizes the membrane. The L-type calcium channel's conductance increases as the basolateral membrane depolarises. (6) The L-type channel is physically in contact with bestrophin which senses the

depletion of intracellular calcium stores and increases the L-type calcium channel's conductance. (7) This store operated calcium entry role for bestrophin conducts chloride as the counter-ion to the calcium current to facilitate calcium entry into the ER and cytoplasm. (8) calcium stores are restored through active transport of calcium through the Ca-ATPase pump, with bestrophin conducting chloride ions into the ER as counter ion.

The light-rise should be considered an RPE response, whether through light directly initiating the generation of IP3 from PIP2 and commencing the intracellular cascade resulting in basolateral depolarisation. If the ability of the RPE to regenerate PIP2 through ATP dependent lipid kinases then changes in the light-rise or fast oscillations may be evident owing to their dependence on apical inward rectifying potassium channels whose gating is regulated by PIP2⁶⁰. With clearer insights into the role of bestrophin at the basolateral interface of the RPE, and the involvement of PIP2 in gating potassium channels and also being the metabolic pre-cursor to IP3 then the light-rise need not depend on an exocrine signal from the rods but be dependent on autocrine signalling from the RPE's apical phospholipid membrane.

Acknowledgements

Thanks to GBA for his work and the anonymous reviewers of this work PAC is funded by a College of Optometrists (UK) research fellowship.

References

1. Griff ER, Steinberg RH. Origin of the light peak: *in vitro* study of *Gekko gekko*. *J Physiol. (Lond)*. 1982;331:637-652.
2. Arden GB, Kelsey JH. Changes produced by light in the standing potential of the human eye. *J. Physiol.* 1962;161:189-204.
3. Arden GB, Barrada A, Kelsey JH. A new clinical test of retinal function based upon the standing potential of the eye. *Br J Ophthalmol.* 1962;46:449-467.
4. Weleber RG. Fast and slow oscillations of the electro-oculogram in best's macular dystrophy and retinitis pigmentosa. *Arch. Ophthalmol.* 1989;107:530-537.
5. Kolb H. Electro-oculogram findings in patients treated with antimalarial drugs. *Br J Ophthalmol.* 1965;49(11):573-90.
6. Harding GF, Wild JM, Robertson KA, et al. Electro-oculography, electroretinography, visual evoked potentials, and multifocal electroretinography in patients with vigabatrin-attributed visual field constriction. *Epilepsia.* 2000;41(11):1420-1431.
7. Strauss O. The retinal pigment epithelium in visual function. *Physiol Rev.* 2005;85(3):845-881.
8. Gallemore RP, Steinberg RH. Light-evoked modulation of basolateral membrane Cl⁻ conductance in chick retinal pigment epithelium: The light peak and fast oscillation. *J. Neurophysiol.* 1993;70(4):1669-1680.
9. Arden GB, Constable PA. The electro-oculogram. *Prog Ret Eye Res.* 2006;25(2):207-248.
10. Rudolf G, Wioland N, Allart I. Is dopamine involved in the generation of the light peak in the intact chicken eye? *Vision Res.* 1991;31(11):1841-9.
11. Quinn RH, Quong JN, Miller SS. Adrenergic receptor activated ion transport in human fetal retinal pigment epithelium. *IOVS.* 2001;42(1):255-264.

12. Mitchell CH, Reigada D. Purinergic signalling in the subretinal space: A role in the communication between the retina and the RPE. *Purinergic Signal*. 2008;4(2):101-107.
13. Reigada D, Lu W, Zhang X, et al. Degradation of extracellular ATP by the retinal pigment epithelium. *Amer. J. Physiol*. 2005;289(3):C617-624.
14. Singh R, Phillips M.J, Kuai, D, et al. Functional analysis of serially expanded human iPS cell-derived RPE cultures. *IOVS*. 2013;54(10):6767-6778.
15. Constable PA, Lawrenson JG, Arden GB. Role of the cystic fibrosis transmembrane conductance regulator in the electro-oculogram. *Doc Ophthalmol*. 2006;113(2):133-143.
16. Constable PA. Nifedipine alters the light-rise of the electro-oculogram in man. *Graefe's Archive Clin Exp Ophthalmol*. 2011;249(5):677-684.
17. Strauss O, Wienrich M. Ca^{2+} -conductances in cultured rat retinal pigment epithelial cells. *J Cell Physiol*. 1994;160(1):89-96.
18. Strauss O, Buss F, Rosenthal R, et al. Activation of neuroendocrine L-type channels ($\alpha 1D$ subunits) in retinal pigment epithelial cells and brain neurons by pp60^{c-src}. *Biochem. Biophys. Res. Commun*. 2000;270(3):806-810.
19. Ueda Y, Steinberg RH. Dihydropyridine-sensitive calcium currents in freshly isolated human and monkey retinal pigment epithelial cells. *IOVS*. 1995;36(2):373-380.
20. Marmorstein AD, Marmorstein LY, Rayborn M, Wang X, Hollyfield JG, Petrukhin K. Bestrophin, the product of the best vitelliform macular dystrophy gene (VMD2), localizes to the basolateral plasma membrane of the retinal pigment epithelium. *Proc Natl Acad Sci*. 2000;97(23):12758-12763.
21. Pollack K, Kreuz F, Pillunat L. Morbus best mit normalem EOG. *Der Ophthalmologe*. 2005;102(9):891-894.

22. Testa F, Rossi S, Passerini I, et al. A normal electro-oculography in a family affected by best disease with a novel spontaneous mutation of the BEST1 gene. *Bri J Ophthalmol*. 2008;92(11):1467-1470.
23. Low S, Davidson AE, Holder GE, et al. Autosomal dominant best disease with an unusual electrooculographic light rise and risk of angle -closure glaucoma: A clinical and molecular genetic study. *Mol Vis*. 2011;17:2722.
24. Strauss O, Rosenthal R. Funktion des bestrophins. *Der Ophthalmologe*. 2005;102(2):122-126.
25. Neussert R, Müller C, Milenkovic V, Strauß O. The presence of bestrophin-1 modulates the Ca²⁺ recruitment from Ca²⁺ stores in the ER. *Pflügers Archiv Eur J Physiol*. 2010;460(1):163-175.
26. Marmorstein AD, Stanton JB, Yocom J, et al. A model of best vitelliform macular dystrophy in rats. *IOVS*. 2004;45(10):3733-3739.
27. Marmorstein LY, Wu J, McLaughlin P, et al. The light peak of the electroretinogram is dependent on voltage-gated calcium channels and antagonized by bestrophin (best-1). *J Gen Physiol*. 2006;127(5):577-589.
28. Loewen ME, Smith NK, Hamilton DL, Grahn BH, Forsyth GW. CLCA protein and chloride transport in canine retinal pigment epithelium. *Am J Physiol Cell Physiol*. 2003;285(5):C1314-1321.
29. Zhang H, Wong CL, Shan SW, et al. Characterisation of Cl⁻ transporter and channels in experimentally induced myopic chick eyes. *Clin Exp Optom*. 2011;94(6):528-535.
30. Kunzelmann K, Kongsuphol P, Chootip K, et al. Role of the Ca²⁺-activated Cl⁻ channels bestrophin and anoctamin in epithelial cells. *Biological Chemistry*. 2011;392(1-2):125-134.
31. Ousingsawat J, Martins JR, Schreiber, R, et al. Loss of TMEM16A causes a defect in epithelial Ca²⁺-dependent chloride transport. *Biological Chemistry*. 2009;284(42):28698-28703.

32. Kunzelmann, K, Kongsuphol P, Aldehni, F, et al. Bestrophin and TMEM16-Ca²⁺ activated Cl⁻ channels with different functions. *Cell Calcium*. 2009;46(4):233-241.33. Gomez NM, Tamm ER, Straubeta O. Role of bestrophin-1 in store-operated calcium entry in retinal pigment epithelium. *Pflugers Arch*. 2013;465(4):481-495.
34. Hogan PG, Lewis RS, Rao A. Molecular basis of calcium signaling in lymphocytes: STIM and ORAI. *Annu Rev Immunol*. 2010;28:491-533.
35. Cordeiro S, Strauss O. Expression of orai genes and ICRAC; activation in the human retinal pigment epithelium. *Graefe's Archive Clin Exp Ophthalmol*. 2010:1-8.
36. Barro-Soria R, Aldehni F, Almaca, J, et al. ER-localized bestrophin 1 activates Ca²⁺-dependent ion channels TMEM16A and SK4 possibly by acting as a counterion channel. *Eur J Physiology*. 2010;459(3):485-497.
37. Heth CA, Marescalchi PA, Ye Y. IP₃ Generation increases rod outer segment phagocytosis by cultured royal college of surgeons retinal pigment epithelium. *IOVS*. 1995;36:981-989.
38. Hall MO, Abrams TA, Mittag TW. ROS ingestion by RPE cells is turned off by increased protein kinase C activity and by increased calcium. *Exp Eye Res*. 1991;52(5):591-598.
39. Gallemore RP, Hughes BA, Miller SS. Retinal pigment epithelial transport mechanisms and their contributions to the electroretinogram. *Prog Ret Eye Res*. 1997;16(4):509-566.
40. Linsenmeier RA, Steinberg RH. Delayed basal hyperpolarization of cat retinal pigment epithelium and its relation to the fast oscillation of the dc electroretinogram. *J Gen Physiol*. 1984;83:213-232.
41. Anderson DH, Fisher SK, Erickson PA, Tabor GA. Rod and cone disc shedding in the rhesus monkey retina: A quantitative study. *Exp Eye Res*. 1980;30(5):559-574.

42. Joseph DP, Miller SS. Apical and basal membrane ion transport mechanisms in bovine retinal pigment epithelium. *J Physiol*. 1991;435:439-463.
43. Kevany BM, Palczewski K. Phagocytosis of retinal rod and cone photoreceptors. *Physiology*. 2010;25(1):8-15.
44. LaVail M. Rod outer segment disk shedding in rat retina: Relationship to cyclic lighting. *Science*. 1976;194(4269):1071-1074.
45. Basinger S, Hoffman R, Matthes M. Photoreceptor shedding is initiated by light in the frog retina. *Science*. 1976;194(4269):1074-1076.
46. Finnemann SC, Bonilha VL, Marmorstein AD, Rodriguez-Boulan E. Phagocytosis of rod outer segments by retinal pigment epithelial cells requires $\alpha\beta5$ integrin for binding but not for internalization. *Proc Natl Acad Sci*. 1997;94(24):12932-12937.
47. Finnemann SC, Silverstein RL. Differential roles of CD36 and $\alpha\beta5$ integrin in photoreceptor phagocytosis by the retinal pigment epithelium. *J Exp Med*. 2001;194(9):1289-1298.
48. Ryeom SW, Sparrow JR, Silverstein RL. CD36 participates in the phagocytosis of rod outer segments by retinal pigment epithelium. *J Cell Sci*. 1996;109 (Pt 2)(Pt 2):387-395.
49. Nandrot EF, Anand M, Almeida D, Atabai K, Sheppard D, Finnemann SC. Essential role for MFG-E8 as ligand for $\alpha\beta5$ integrin in diurnal retinal phagocytosis. *Proc Natl Acad Sci*. 2007;104(29):12005-12010.
50. D'Cruz PM, Yasumura D, Weir J et al. Mutation of the receptor tyrosine kinase gene *Mertk* in the retinal dystrophic RCS rat. *Human Molecular Genetics*. 2000;9(4):645-651.
51. Gal A, Li Y, Thompson DA, et al. Mutations in MERTK, the human orthologue of the RCS rat retinal dystrophy gene, cause retinitis pigmentosa. *Nat Genet*. 2000;26(3):270-271.

52. D'Cruz PM, Yasumura D, Weir J, et al. Mutation of the receptor tyrosine kinase gene *merck* in the retinal dystrophic RCS rat. *Human Molecular Genetics*. 2000;9(4):645-651.
53. Hall MO, Obin MS, Heeb MJ, Burgess BL, Abrams TA. Both protein S and Gas6 stimulate outer segment phagocytosis by cultured rat retinal pigment epithelial cells. *Exp Eye Res*. 2005;81(5):581-591.
54. Mao Y, Finnemann SC. Essential diurnal Rac1 activation during retinal phagocytosis requires $\alpha\beta 5$ integrin but not tyrosine kinases focal adhesion kinase or mer tyrosine kinase. *Mol Biol Cell*. 2012;23(6):1104-1114.
55. Finnemann SC. Focal adhesion kinase signalling promotes phagocytosis of integrin-bound photoreceptors. *EMBO J*. 2003;22(16):4143-4154.
56. Rodriguez De Turco EB, Gordon WC, Bazan NG. Light stimulates in vivo inositol lipid turnover in frog retinal pigment epithelial cells at the onset of shedding and phagocytosis of photoreceptor membranes. *Exp Eye Res*. 1992;55(5):719-725.
57. Heth CA, Marescalchi PA. Inositol triphosphate generation in cultured rat retinal pigment epithelium. *IOVS*. 1994;35(2):409-416.
58. Anderson DH, Stern WH, Fisher SK, Erickson PA, Borgula GA. Retinal detachment in the cat: The pigment epithelial-photoreceptor interface. *IOVS*. 1983;24(7):906-926.
59. Johnson NF, Foulds WS. Observations on the retinal pigment epithelium and retinal macrophages in experimental retinal detachment. *Br J Ophthalmol*. 1977;61(9):564-572.
60. Pattnaik BR, Hughes BA. Regulation of k_{ir} channels in bovine retinal pigment epithelial cells by phosphatidylinositol 4,5-bisphosphate. *Am J Physiol Cell Physiol*. 2009; 297(4): C1001-11.
-